

Linear IC General purpose Converter

CMOS

D/A Converter for Digital Tuning (8 channels. 8-bit, with OP amplifier)

MB88347

■ DESCRIPTION

The MB88347 features 8 channels of 8-bit D/A converters (with output amplifiers). The output amplifier provides high current drive capability. As data is input via a serial link, only three control lines are required, and cascaded connections can be used.

The MB88347 is suitable for electronic volumes and replacement for potentiometers for adjustment, in addition to normal D/A converter applications.

■ FEATURES

- Low power consumption (2 mW/ch)
- Small package
- Integrating 8 channels of R-2R type 8-bit D/A converter.

(Continued)

■ PACKAGES

16-pin plastic DIP

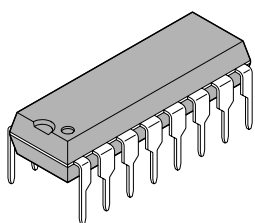

(DIP-16P-M04)

16-pin plastic SOP

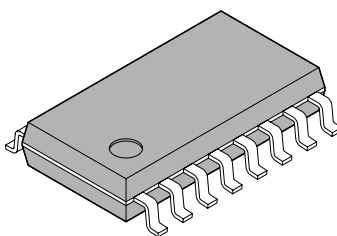

(FPT-16P-M06)

16-pin plastic SSOP

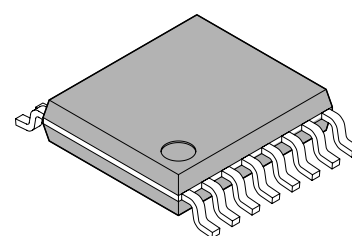

(FPT-16P-M05)

MB88347

(Continued)

- Built-in analog output amplifier (Max +1.0 mA sink/source current)
- Analog output range : 0 to V_{CC}
- The range of D/A conversion can be independently set by separated the power supply for MCU interface and OP amplifier and the power supply for D/A converter.
- Capable of being controlled directly by a 3-V MCU (input voltage : “H” = $0.5 V_{CC}$, “L” = $0.2 V_{CC}$)
- Serial data input, 2.5 MHz operation
- CMOS process
- Package lineup : DIP 16-pin, SOP 16-pin, SSOP 16-pin

■ PIN ASSIGNMENT

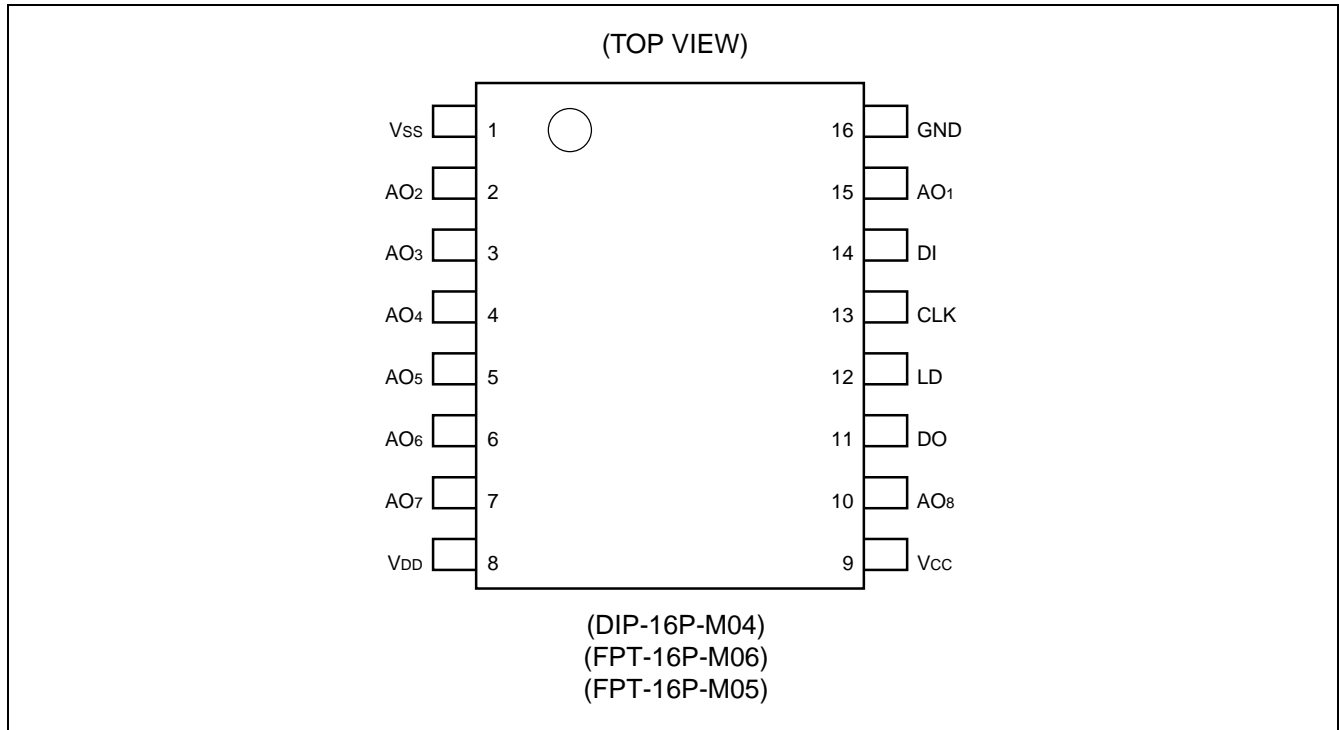

■ PIN DESCRIPTION

Pin No.	Symbol	I/O	Pin name	Function
14	DI*	I	Data input pin	Serial data input pin. This pin inputs 12-bit length serial data.
11	DO	O	Data output pin	This pin outputs MSB bit data of 12-bit shift register.
13	CLK*	I	Shift clock input pin	Shift clock input pin. The input signal from the DI pin is inputted to a 12-bit shift register on the rising edge of the shift clock.
12	LD*	I	Load signal input pin	If input "H" level to LD pin, the data of shift register is loaded to the decoder and the register for D/A output.
15 2 3 4 5 6 7 10	AO ₁ AO ₂ AO ₃ AO ₄ AO ₅ AO ₆ AO ₇ AO ₈	O	D/A output pin	These pins are 8-bit D/A output with OP amplifier.
9	V _{CC}	—	Power supply pin	Power supply pin of MCU interface and OP amplifier
16	GND	—	Ground pin	Ground pin of MCU interface and OP amplifier
8	V _{DD}	—	Power supply pin	Power supply pin of D/A converter
1	V _{SS}	—	Ground pin	Ground pin of D/A converter

* : DI, CLK, and LD pins are fixed to "L" level at non transfer.

■ BLOCK DIAGRAM

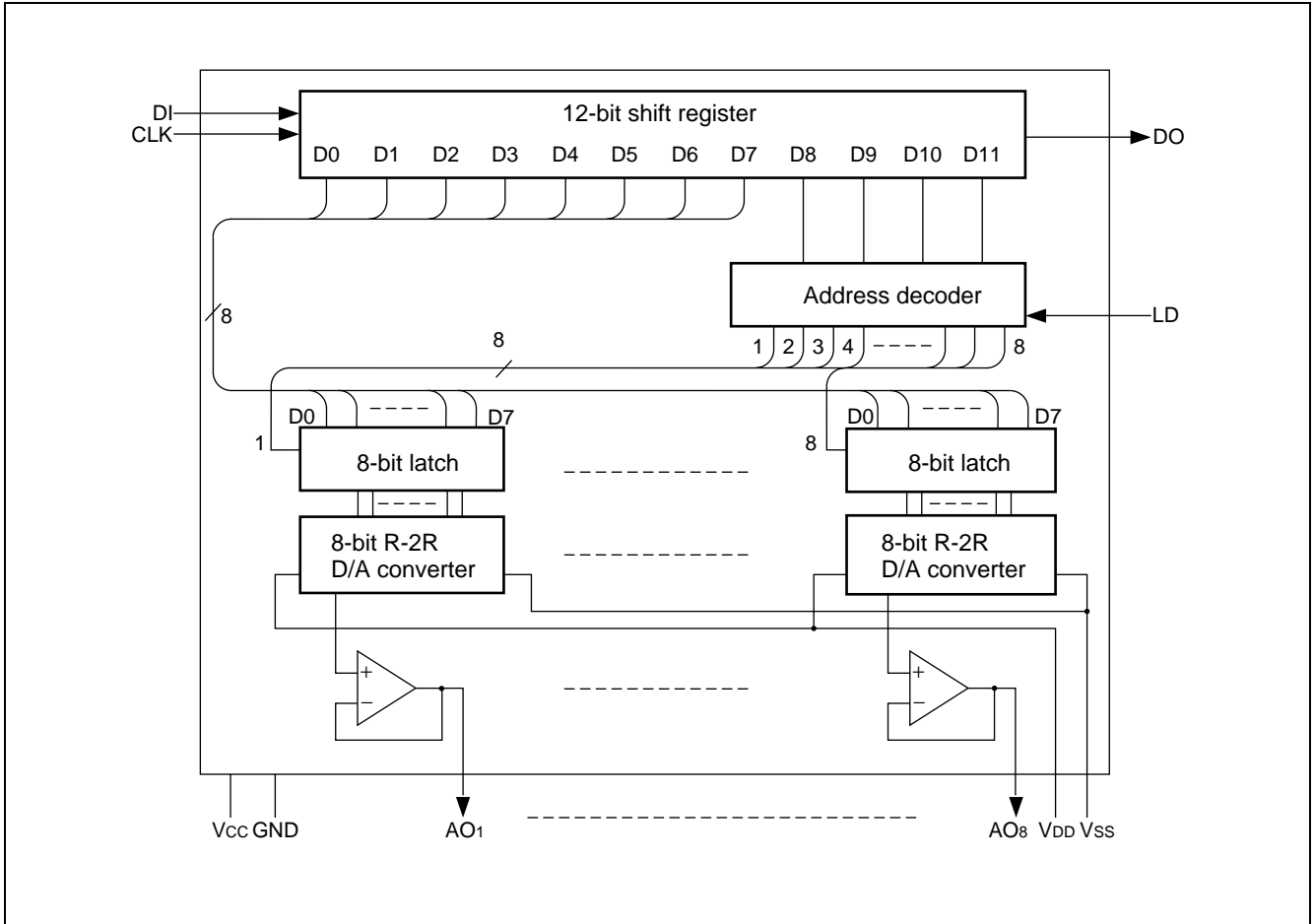

■ DATA FOR CHIP CONTROL

1. Data for Shift Register

- MB88347 has 12-bit shift register for chip control.
- It is necessary to set the data as following configuration to 12-bit shift register.
- The data consists of 12 bits: a 4-bit address selection and an 8-bit D/A converter control signal.

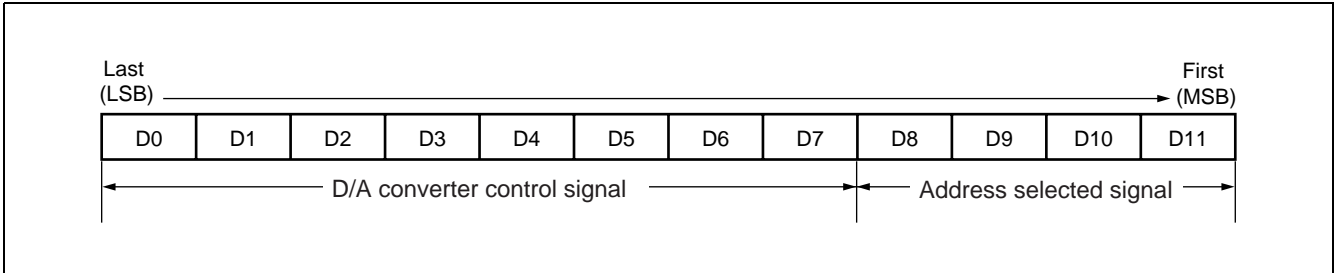

2. D/A Converter Control Signal

Input data signal								D/A converter output voltage
D0	D1	D2	D3	D4	D5	D6	D7	
0	0	0	0	0	0	0	0	$\neq V_{SS}$
1	0	0	0	0	0	0	0	$\neq V_{LB} + V_{SS}$
0	1	0	0	0	0	0	0	$\neq V_{LB} \times 2 + V_{SS}$
⋮	⋮	⋮	⋮	⋮	⋮	⋮	⋮	⋮
0	1	1	1	1	1	1	1	$\neq V_{LB} \times 254 + V_{SS}$
1	1	1	1	1	1	1	1	$\neq V_{DD}$

$$V_{LB} = (V_{DD} - V_{SS}) / 255$$

3. Address Selected Signal

Input data signal				Address selected
D8	D9	D10	D11	
0	0	0	0	Don't Care
0	0	0	1	AO ₁ selected
0	0	1	0	AO ₂ selected
0	0	1	1	AO ₃ selected
0	1	0	0	AO ₄ selected
0	1	0	1	AO ₅ selected
0	1	1	0	AO ₆ selected
0	1	1	1	AO ₇ selected
1	0	0	0	AO ₈ selected
1	0	0	1	Don't Care
1	0	1	0	Don't Care
1	0	1	1	Don't Care
1	1	0	0	Don't Care
1	1	0	1	Don't Care
1	1	1	0	Don't Care
1	1	1	1	Don't Care

■ TIMING CHART AT DATA SETTING

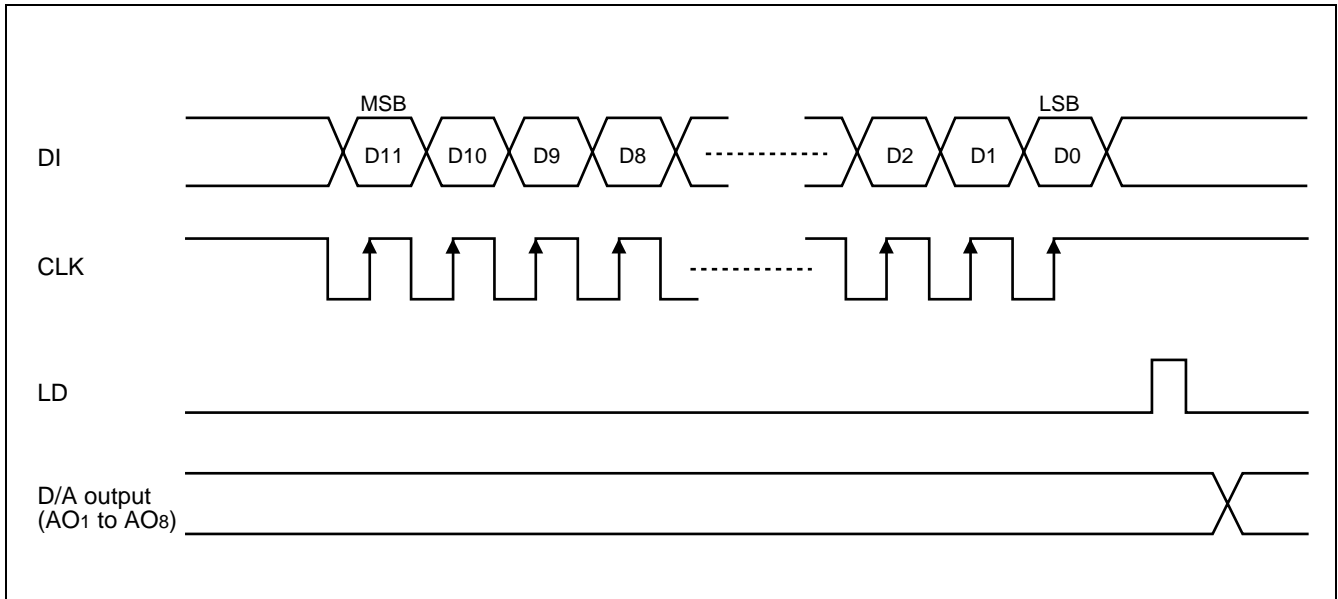

■ ANALOG OUTPUT VOLTAGE RANGE

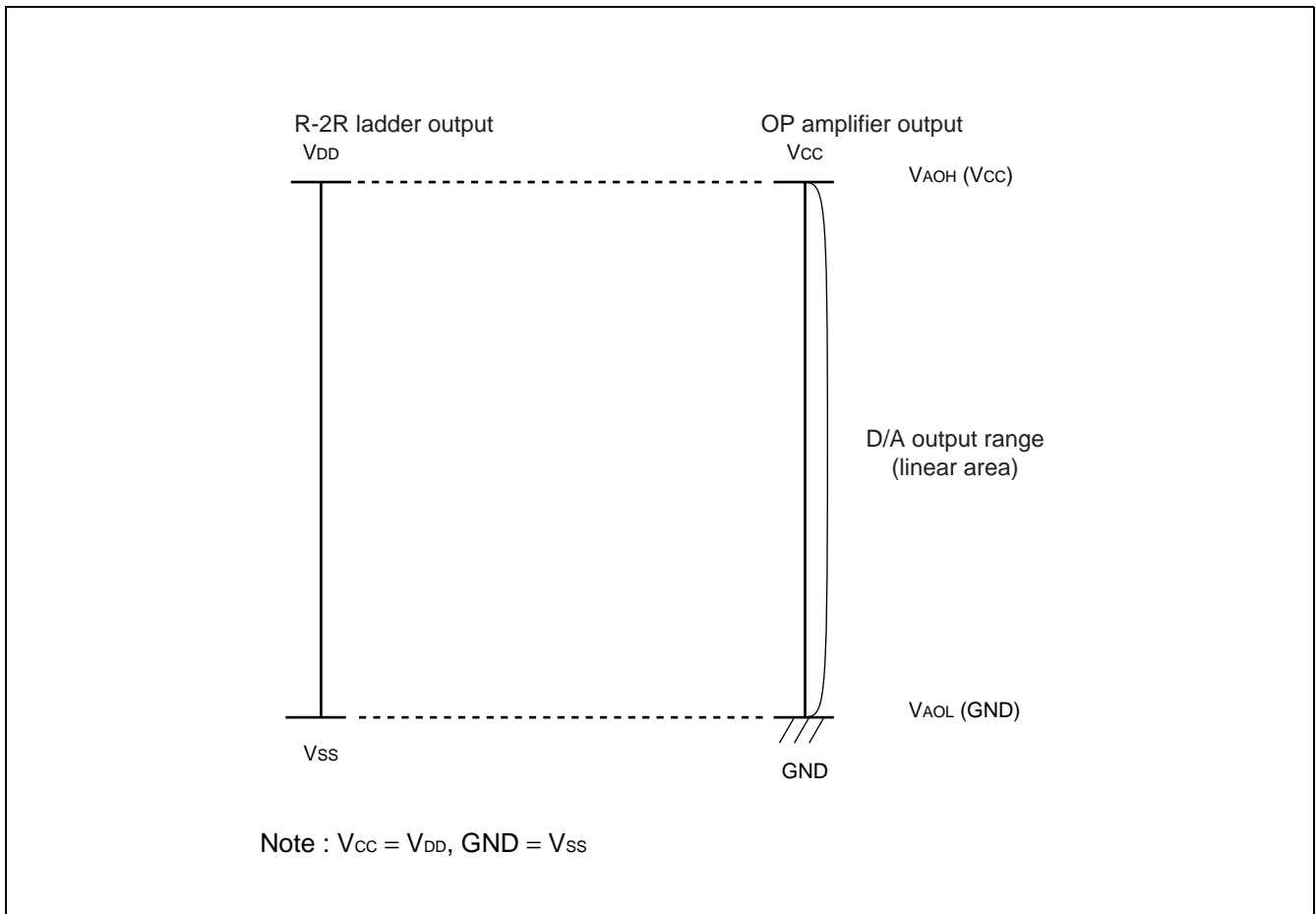

■ ABSOLUTE MAXIMUM RATINGS

Parameter	Symbol	Condition	Rating		Unit
			Min	Max	
Power supply voltage	V _{CC}	The case that GND is referred. Ta = +25 °C	- 0.3	+ 7.0	V
	V _{DD}		- 0.3*	+ 7.0*	V
Input voltage	V _{IN}		- 0.3	V _{CC} + 0.3	V
Output voltage	V _{OUT}		- 0.3	V _{CC} + 0.3	V
Power consumption	P _D	—	—	250	mW
Operating temperature	Ta	—	- 40	+ 85	°C
Storage temperature	Tstg	—	- 55	+ 150	°C

* : V_{CC} ≥ V_{DD}

WARNING: Semiconductor devices can be permanently damaged by application of stress (voltage, current, temperature, etc.) in excess of absolute maximum ratings. Do not exceed these ratings.

■ RECOMMENDED OPERATING CONDITIONS

Parameter	Symbol	Condition	Value		Unit
			Min	Max	
Power supply Voltage 1	V _{CC}	—	4.5	5.5	V
	GND	—	—	0	V
Power supply Voltage 2	V _{DD}	V _{DD} - V _{SS} ≥ 2.0 V	2.0	V _{CC}	V
	V _{SS}		GND	V _{CC} - 2.0	V
Analog output source current	I _{AL}	—	—	1.0	mA
Analog output sink current	I _{AH}	—	—	1.0	mA
Oscillation limited output capacitance	C _{OL}	—	—	1.0	μF
Digital data setting range	—	—	#00	#FF	—
Operating temperature	Ta	—	- 40	+ 85	°C

WARNING: The recommended operating conditions are required in order to ensure the normal operation of the semiconductor device. All of the device's electrical characteristics are warranted when the device is operated within these ranges.

Always use semiconductor devices within their recommended operating condition ranges. Operation outside these ranges may adversely affect reliability and could result in device failure.

No warranty is made with respect to uses, operating conditions, or combinations not represented on the data sheet. Users considering application outside the listed conditions are advised to contact their FUJITSU representatives beforehand.

■ ELECTRICAL CHARACTERISTICS

1. DC Characteristics

(1) Digital block

($V_{DD}, V_{CC} = +5\text{ V} \pm 10\%$ ($V_{CC} \geq V_{DD}$), $GND, V_{SS} = 0\text{ V}$, $T_a = -40\text{ }^\circ\text{C}$ to $+85\text{ }^\circ\text{C}$)

Parameter	Symbol	Pin name	Conditions	Value			Unit
				Min	Typ	Max	
Power supply voltage	V_{CC}	V_{CC}	—	4.5	5.0	5.5	V
Power supply current	I_{CC}		At CLK = 1 MHz operating (at no load) At $T_a = -20\text{ }^\circ\text{C}$ to $+85\text{ }^\circ\text{C}$	—	0.8	1.8	mA
			At CLK = 1 MHz operating (at no load) At $T_a = -40\text{ }^\circ\text{C}$ to $+85\text{ }^\circ\text{C}$	—	0.8	2.1	
Input leakage current	I_{ILK}	CLK DI LD	$V_{IN} = 0$ to V_{CC}	-10	—	10	μA
“L” level input voltage	V_{IL}		—	—	—	$0.2 V_{CC}$	V
“H” level input voltage	V_{IH}		—	$0.5 V_{CC}$	—	—	V
“L” level output voltage	V_{OL}	DO	$I_{OL} = 2.5\text{ mA}$	—	—	0.4	V
“H” level output voltage	V_{OH}		$I_{OH} = -400\text{ }\mu\text{A}$	$V_{CC} - 0.4$	—	—	V

Note : I_{OL} and I_{OH} are output load current.

MB88347

(2) Analog block

($V_{DD}, V_{CC} = +5\text{ V} \pm 10\%$ ($V_{CC} \geq V_{DD}$), $GND, V_{SS} = 0\text{ V}$, $T_a = -40\text{ }^\circ\text{C}$ to $+85\text{ }^\circ\text{C}$)

Parameter	Symbol	Pin name	Conditions	Value			Unit
				Min	Typ	Max	
Consumption current	I_{DD}	V_{DD}	No load	—	1.0	1.5	mA
Analog power supply voltage	V_{DD}	V_{DD}	$V_{DD} - V_{SS} \geq 2.0\text{ V}$	2.0	—	V_{CC}	V
	V_{SS}	V_{SS}		GND	—	$V_{CC} - 2.0$	V
Resolution	Res	AO ₁ to AO ₈	—	—	8	—	bit
Monotonic increase	Rem		—	—	8	—	bit
Non linearity error* ¹	LE		No load $V_{DD} \leq V_{CC} - 0.1\text{ V}$ $V_{SS} \geq 0.1\text{ V}$	—1.5	—	1.5	LSB
Differential linearity error* ²	D_{LE}		—1.0	—	1.0	LSB	
Output minimum voltage 1	V_{AOL1}		$V_{DD} = V_{CC}$ $V_{SS} = GND = 0.0\text{ V}$ $I_{AL} = 0\text{ }\mu\text{A}$ Digital data = #00	V_{SS}	—	$V_{SS} + 0.1$	V
Output minimum voltage 2	V_{AOL2}	$V_{DD} = V_{CC} = 5.0\text{ V}$ $V_{SS} = GND = 0.0\text{ V}$ $I_{AL} = 500\text{ }\mu\text{A}$ Digital data = #00	$V_{SS} - 0.2$	V_{SS}	$V_{SS} + 0.2$	V	
Output minimum voltage 3	V_{AOL3}	$V_{DD} = V_{CC} = 5.0\text{ V}$ $V_{SS} = GND = 0.0\text{ V}$ $I_{AH} = 500\text{ }\mu\text{A}$ Digital data = #00	V_{SS}	—	$V_{SS} + 0.2$	V	
Output minimum voltage 4	V_{AOL4}	$V_{DD} = V_{CC} = 5.0\text{ V}$ $V_{SS} = GND = 0.0\text{ V}$ $I_{AL} = 1.0\text{ mA}$ Digital data = #00	$V_{SS} - 0.3$	V_{SS}	$V_{SS} + 0.3$	V	
Output minimum voltage 5	V_{AOL5}	$V_{DD} = V_{CC} = 5.0\text{ V}$ $V_{SS} = GND = 0.0\text{ V}$ $I_{AH} = 1.0\text{ mA}$ Digital data = #00	V_{SS}	—	$V_{SS} + 0.3$	V	

(Continued)

(Continued)

($V_{DD}, V_{CC} = +5\text{ V} \pm 10\%$ ($V_{CC} \geq V_{DD}$), $GND, V_{SS} = 0\text{ V}$, $T_a = -40\text{ }^\circ\text{C}$ to $+85\text{ }^\circ\text{C}$)

Parameter	Symbol	Pin name	Conditions	Value			Unit
				Min	Typ	Max	
Output maximum voltage 1	V_{AOH1}	AO ₁ to AO ₈	$V_{DD} = V_{CC}$ $V_{SS} = GND = 0.0\text{ V}$ $I_{AL} = 0\text{ }\mu\text{A}$ Digital data = #FF	$V_{DD} - 0.1$	—	V_{DD}	V
Output maximum voltage 2	V_{AOH2}		$V_{DD} = V_{CC} = 5.0\text{ V}$ $V_{SS} = GND = 0.0\text{ V}$ $I_{AL} = 500\text{ }\mu\text{A}$ Digital data = #FF	$V_{DD} - 0.2$	—	V_{DD}	V
Output maximum voltage 3	V_{AOH3}		$V_{DD} = V_{CC} = 5.0\text{ V}$ $V_{SS} = GND = 0.0\text{ V}$ $I_{AH} = 500\text{ }\mu\text{A}$ Digital data = #FF	$V_{DD} - 0.2$	V_{DD}	$V_{DD} + 0.2$	V
Output maximum voltage 4	V_{AOH4}		$V_{DD} = V_{CC} = 5.0\text{ V}$ $V_{SS} = GND = 0.0\text{ V}$ $I_{AL} = 1.0\text{ mA}$ Digital data = #FF	$V_{DD} - 0.3$	—	V_{DD}	V
Output maximum voltage 5	V_{AOH5}		$V_{DD} = V_{CC} = 5.0\text{ V}$ $V_{SS} = GND = 0.0\text{ V}$ $I_{AH} = 1.0\text{ mA}$ Digital data = #FF	$V_{DD} - 0.3$	V_{DD}	$V_{DD} + 0.3$	V

*1 : Non linearity error : The error of the I/O curve from the ideal straight line between output voltages at "00" and "FF".

*2 : Differential linearity error : The error from the ideal increment given when the digital value is incremented by one bit.

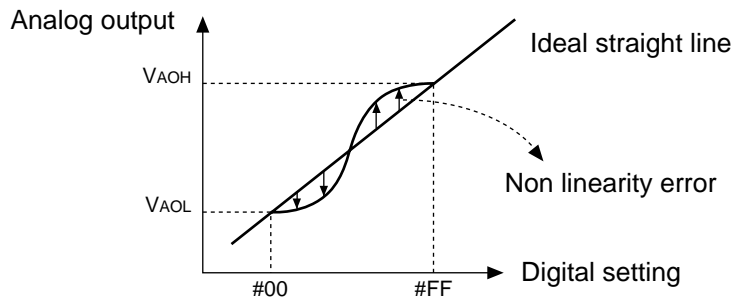

Note: V_{AOH} and V_{AOL} do not always match V_{DD} and V_{SS} , respectively.

2. AC Characteristics

($V_{DD}, V_{CC} = +5\text{ V} \pm 10\%$ ($V_{CC} \geq V_{DD}$), $GND, V_{SS} = 0\text{ V}$, $T_a = -40\text{ }^\circ\text{C}$ to $+85\text{ }^\circ\text{C}$)

Parameter	Symbol	Conditions	Value		Unit
			Min	Max	
"L" level clock pulse width	t_{CKL}	—	200	—	ns
"H" level clock pulse width	t_{CKH}	—	200	—	ns
Clock rising time Clock falling time	t_{Cr} t_{Cf}	—	—	200	ns
Data setup time	t_{DCH}	—	30	—	ns
Data hold time	t_{CHD}	—	60	—	ns
Load setup time	t_{CHL}	—	200	—	ns
Load hold time	t_{LDC}	—	100	—	ns
"H" level load pulse width	t_{LDH}	—	100	—	ns
Data output delay time	t_{DO}	Refer to "Load condition (1)".	70	350	ns
D/A output settling time	t_{LDD}	Refer to "Load condition (2)".	—	100	μs

• Load condition

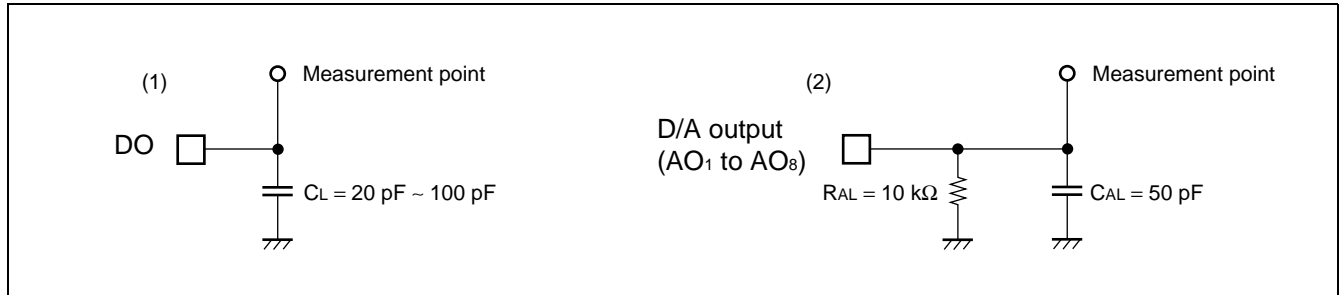

• Input/output timing

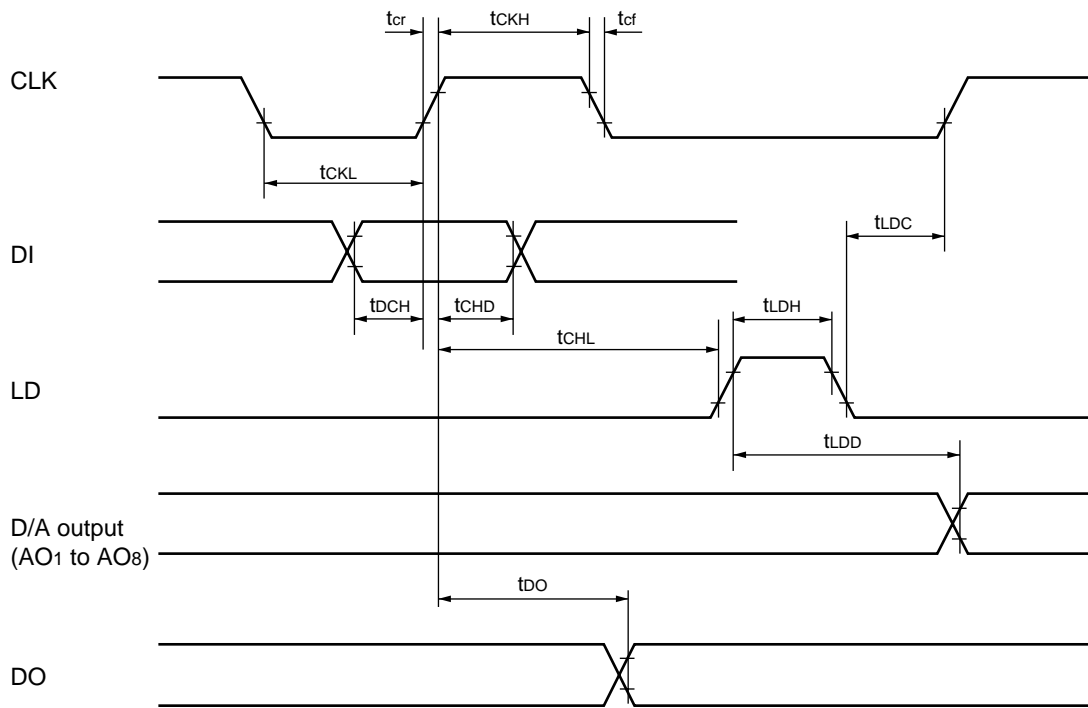

Note : The D/A output evaluation level is 90% and 10% of V_{CC} . The other evaluation level is 80% and 20% of V_{CC} .

■ EXAMPLE CHARACTERISTIC of $V_{AO} - I_{AO}$

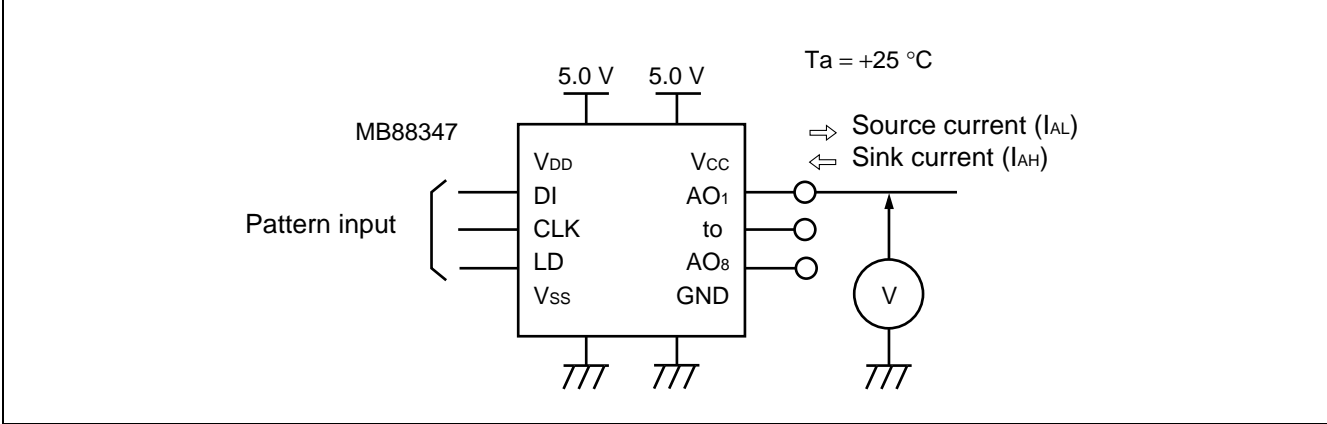

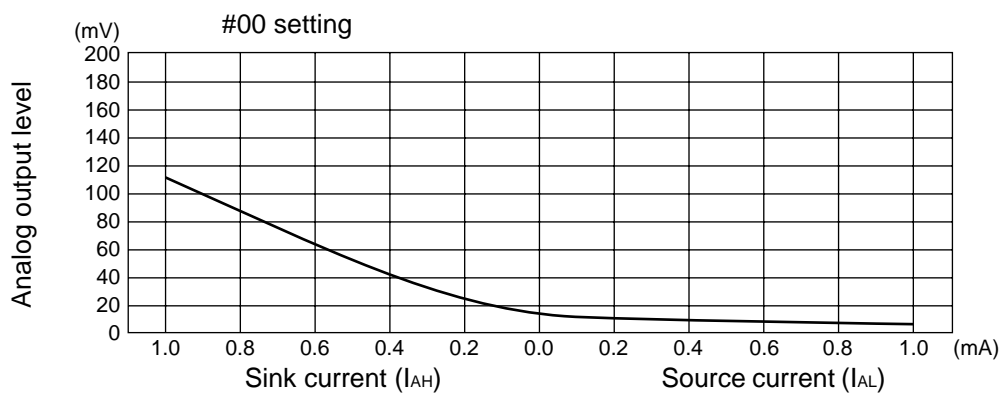
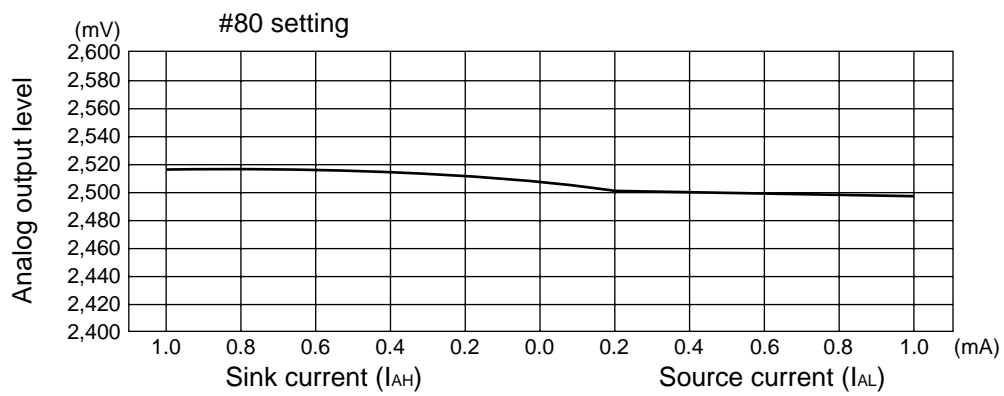
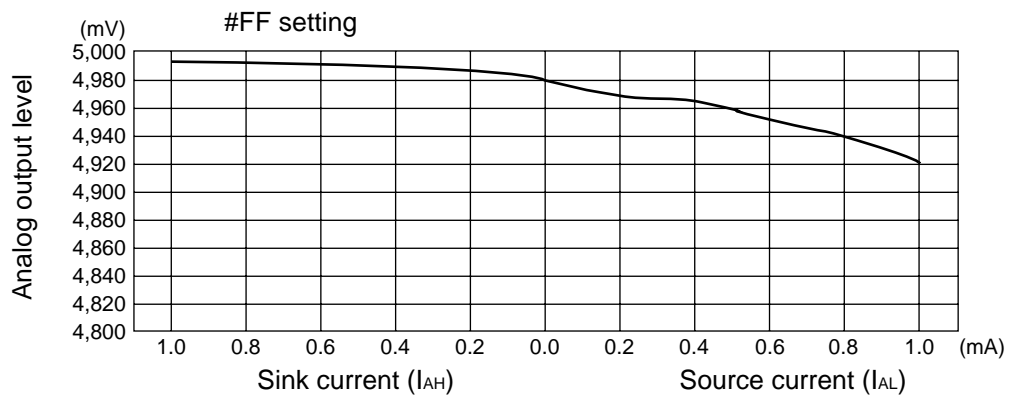

MB88347

■ ORDERING INFORMATION

Part No.	Package	Remarks
MB88347P	16-pin plastic DIP (DIP-16P-M04)	
MB88347PF	16-pin plastic SOP (FPT-16P-M06)	
MB88347PFV	16-pin plastic SSOP (FPT-16P-M05)	

■ PACKAGE DIMENSIONS

16-pin plastic DIP
(DIP-16P-M04)

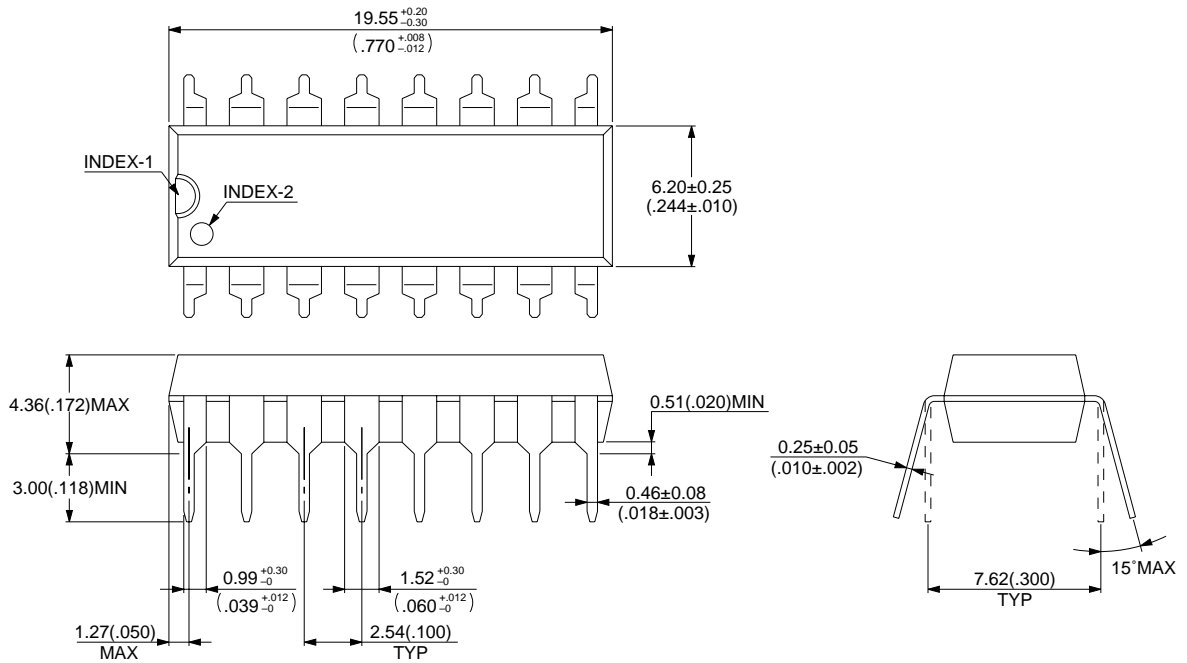

© 1994 FUJITSU LIMITED D16033S-2C-3

Dimensions in mm (inches).

Note : The values in parentheses are reference values.

(Continued)

MB88347

16-pin plastic SOP
(FPT-16P-M06)

- Note 1) *1 : These dimensions include resin protrusion.
- Note 2) *2 : These dimensions do not include resin protrusion.
- Note 3) Pins width and pins thickness include plating thickness.
- Note 4) Pins width do not include tie bar cutting remainder.

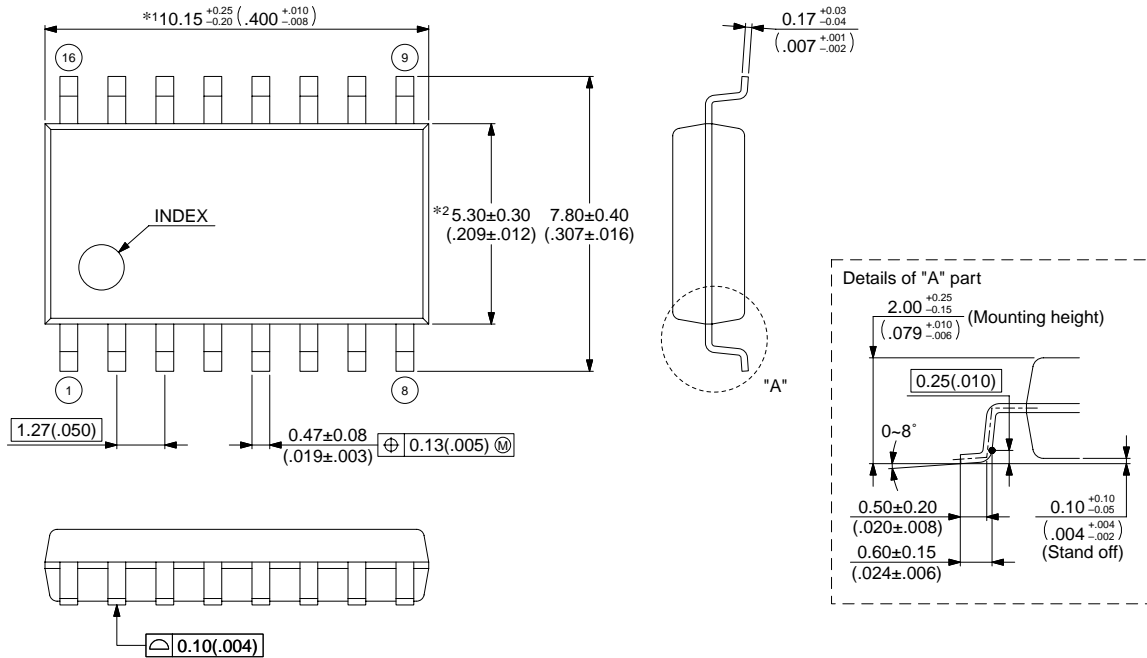

© 2002 FUJITSU LIMITED F16015S-c-4-7

Dimensions in mm (inches).

Note: The values in parentheses are reference values.

(Continued)

(Continued)

16-pin plastic SSOP
(FPT-16P-M05)

- Note 1) *1 : Resin protrusion. (Each side : +0.15 (.006) Max).
- Note 2) *2 : These dimensions do not include resin protrusion.
- Note 3) Pins width and pins thickness include plating thickness.
- Note 4) Pins width do not include tie bar cutting remainder.

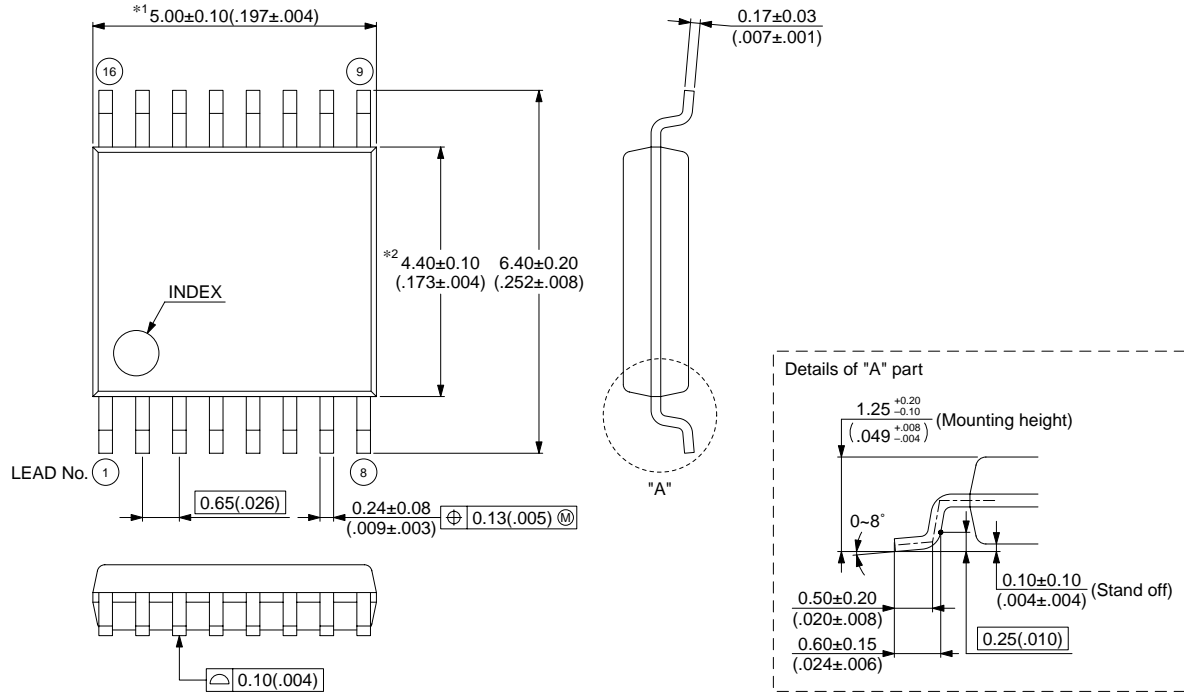

© 2003 FUJITSU LIMITED F16013S-c-4-6

Dimensions in mm (inches).

Note: The values in parentheses are reference values.

FUJITSU LIMITED

All Rights Reserved.

The contents of this document are subject to change without notice. Customers are advised to consult with FUJITSU sales representatives before ordering.

The information, such as descriptions of function and application circuit examples, in this document are presented solely for the purpose of reference to show examples of operations and uses of Fujitsu semiconductor device; Fujitsu does not warrant proper operation of the device with respect to use based on such information. When you develop equipment incorporating the device based on such information, you must assume any responsibility arising out of such use of the information. Fujitsu assumes no liability for any damages whatsoever arising out of the use of the information.

Any information in this document, including descriptions of function and schematic diagrams, shall not be construed as license of the use or exercise of any intellectual property right, such as patent right or copyright, or any other right of Fujitsu or any third party or does Fujitsu warrant non-infringement of any third-party's intellectual property right or other right by using such information. Fujitsu assumes no liability for any infringement of the intellectual property rights or other rights of third parties which would result from the use of information contained herein.

The products described in this document are designed, developed and manufactured as contemplated for general use, including without limitation, ordinary industrial use, general office use, personal use, and household use, but are not designed, developed and manufactured as contemplated (1) for use accompanying fatal risks or dangers that, unless extremely high safety is secured, could have a serious effect to the public, and could lead directly to death, personal injury, severe physical damage or other loss (i.e., nuclear reaction control in nuclear facility, aircraft flight control, air traffic control, mass transport control, medical life support system, missile launch control in weapon system), or (2) for use requiring extremely high reliability (i.e., submersible repeater and artificial satellite).

Please note that Fujitsu will not be liable against you and/or any third party for any claims or damages arising in connection with above-mentioned uses of the products.

Any semiconductor devices have an inherent chance of failure. You must protect against injury, damage or loss from such failures by incorporating safety design measures into your facility and equipment such as redundancy, fire protection, and prevention of over-current levels and other abnormal operating conditions.

If any products described in this document represent goods or technologies subject to certain restrictions on export under the Foreign Exchange and Foreign Trade Law of Japan, the prior authorization by Japanese government will be required for export of those products from Japan.