

RF MOSFET Power Transistor, 40W, 28V

100 - 500 MHz

UF2840G

V2.00

Features

- N-Channel Enhancement Mode Device
- DMOS Structure
- Lower Capacitances for Broadband Operation
- High Saturated Output Power
- Lower Noise Figure Than Competitive Devices

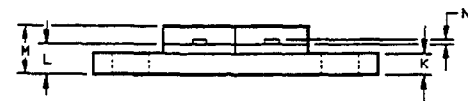
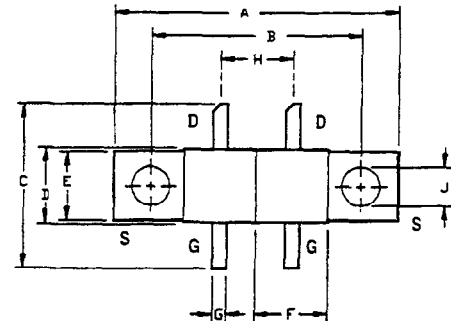

Absolute Maximum Ratings at 25°C

Parameter	Symbol	Rating	Units
Drain-Source Voltage	V_{DS}	65	V
Gate-Source Voltage	V_{GS}	20	V
Drain-Source Current	I_{DS}	4*	A
Power Dissipation	P_D	116	W
Junction Temperature	T_J	200	°C
Storage Temperature	T_{STG}	-55 to +150	°C
Thermal Resistance	θ_{JC}	1.52	°C/W

LETTER DIM	MILLIMETERS		INCHES	
	MIN	MAX	MIN	MAX
A	24.64	24.89	.970	.980
B	18.29	18.54	.720	.730
C	13.72	14.22	.540	.560
D	6.22	6.48	.245	.255
E	5.72	5.97	.225	.235
F	6.22	6.48	.245	.255
G	1.14	1.40	.045	.055
H	6.22	6.48	.245	.255
J	3.18	3.43	.125	.135
K	1.78	2.03	.070	.080
L	2.34	2.84	.092	.112
M	3.99	4.75	.157	.187
N	.08	.15	.003	.006

Electrical Characteristics at 25°C

Parameter	Symbol	Min	Max	Units	Test Conditions
Drain-Source Breakdown Voltage	BV_{DSS}	65	-	V	$V_{GS}=0.0\text{ V}, I_{DS}=5.0\text{ mA}^*$
Drain-Source Leakage Current	I_{DSS}	-	1.0	mA	$V_{DS}=28.0\text{ V}, V_{GS}=0.0\text{ V}^*$
Gate-Source Leakage Current	I_{GSS}	-	1.0	μA	$V_{GS}=20\text{ V}, V_{DS}=0.0\text{ V}^*$
Gate Threshold Voltage	$V_{GS(TH)}$	2.0	6.0	V	$V_{DS}=10.0\text{ V}, I_{DS}=100.0\text{ mA}^*$
Forward Transconductance	G_M	.500	-	S	$V_{DS}=10.0\text{ V}, I_{DS}=1.0\text{ A}, \Delta V_{GS}=1.0\text{ V}, 80\mu\text{s Pulse}^*$
Input Capacitance	C_{ISS}	-	45	pF	$V_{DS}=28.0\text{ V}, F=1.0\text{ MHz}^*$
Output Capacitance	C_{OSS}	-	30	pF	$V_{DS}=28.0\text{ V}, F=1.0\text{ MHz}^*$
Reverse Capacitance	C_{RSS}	-	8	pF	$V_{DS}=28.0\text{ V}, F=1.0\text{ MHz}^*$
Power Gain	G_P	10	-	dB	$V_{DD}=28.0\text{ V}, I_{DQ}=500.0\text{ mA}, P_{OUT}=40.0\text{ W}, F=500\text{ MHz}$
Drain Efficiency	η_D	50	-	%	$V_{DD}=28.0\text{ V}, I_{DQ}=500.0\text{ mA}, P_{OUT}=40.0\text{ W}, F=500\text{ MHz}$
Load Mismatch Tolerance	VSWR-T	-	30:1	-	$V_{DD}=28.0\text{ V}, I_{DQ}=500.0\text{ mA}, P_{OUT}=40.0\text{ W}, F=500\text{ MHz}$

* Per Side

Specifications Subject to Change Without Notice.

Typical Broadband Performance Curves

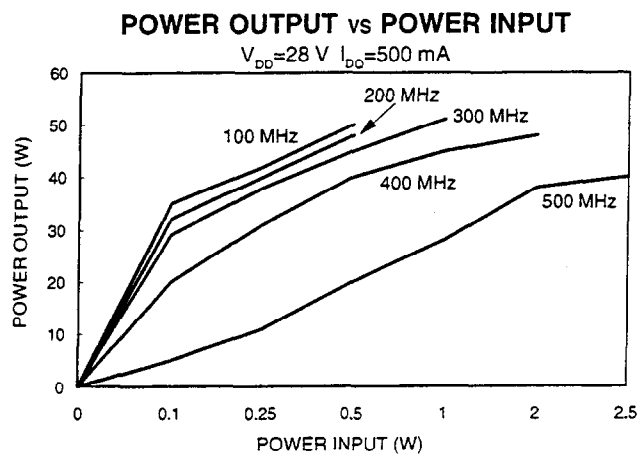
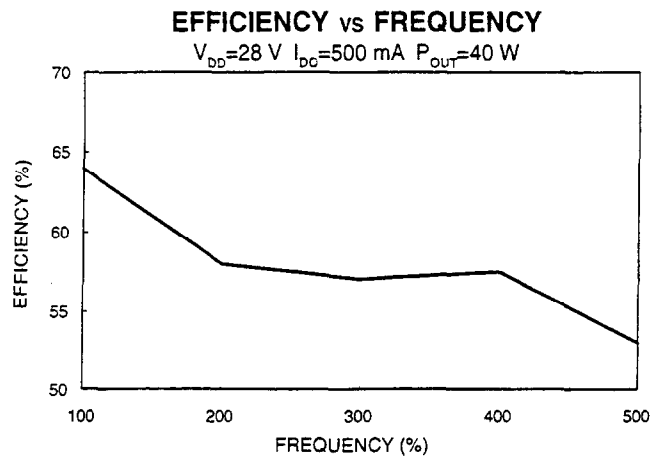
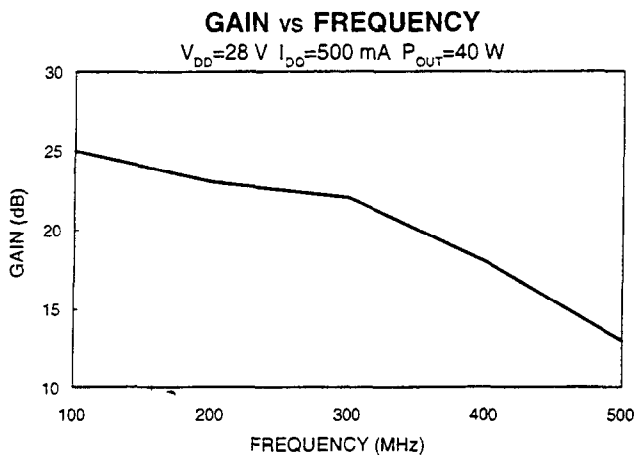

Typical Device Impedance

Frequency (MHz)	Z_{IN} (OHMS)	Z_{LOAD} (OHMS)
100	6.0 - j 20.0	25.0 + j 27.0
200	3.5 - j 11.5	16.5 + j 19.5
300	2.5 - j 5.5	13.0 + j 13.0
400	3.0 + j 0.0	12.0 + j 9.0
500	4.0 + j 3.0	12.0 + j 5.0

$V_{DD}=28$ V, $I_{DQ}=500$ mA, $P_{OUT}=40.0$ Watts

Z_{IN} is the series equivalent input impedance of the device from gate to gate.

Z_{LOAD} is the optimum series equivalent load impedance as measured from drain to ground.

RF Test Fixture

$V_{DS} = 28$ VOLTS
 $I_{DQ} = 500$ mA

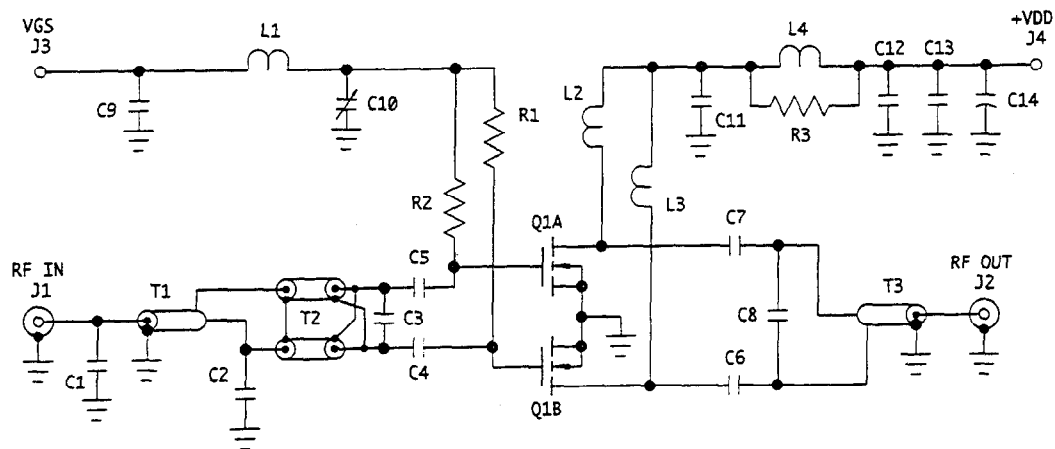

PARTS LIST

C1, C3	CAPACITOR 15pF
C2	CAPACITOR 7pF
C4, C5, C6,	CHIP CAPACITOR 620pF ATC
C7	CHIP CAPACITOR 9.1pF ATC
C8	CHIP CAPACITOR 9.1pF ATC
C9, C12	CAPACITOR 1000pF
C10	TRIMMER CAPACITOR 2-500pF
C11	CAPACITOR ATC 500pF
C13	MONOLITHIC CERAMIC CAPACITOR 0.1uF
C14	ELECTROLYTIC CAPACITOR 50uF 50 V.
L1	4 TURNS OF NO. 22 AWG ON '0.35"
L2, L3	6 TURNS OF NO. 22 AWG ON '0.35"
L4	8 TURNS OF NO. 22 AWG ON R3
R1, R2	RESISTOR 12K OHMS 0.25 WATT
R3	RESISTOR 33 OHMS 3 WATTS
T1	50 OHM SEMI-RIGID COAX 2.1" X '0.085"
T2	25 OHM SEMI-RIGID COAX 2X 2.3" X '0.070"
T3	25 OHM SEMI-RIGID COAX 3.3" X '0.070"
Q1	UF2840G
BOARD	FR4 0.062"

Specifications Subject to Change Without Notice.