

# NHD-0208BZ-FL-YBW

## Character Liquid Crystal Display Module

NHD-	Newhaven Display
0208-	2 lines x 8 characters
BZ-	Model
F-	Transflective
L-	Yellow/Green LED Backlight
Y-	STN- Yellow/Green
B-	6:00 view
W-	Wide Temperature (-20°C~+70°C)

**RoHS Compliant**

**Newhaven Display International, Inc.**

2511 Technology Drive, Suite 101

Elgin IL, 60124

Ph: 847-844-8795

Fax: 847-844-8796

[www.newhavendisplay.com](http://www.newhavendisplay.com)

[nhtech@newhavendisplay.com](mailto:nhtech@newhavendisplay.com)

[nhsales@newhavendisplay.com](mailto:nhsales@newhavendisplay.com)

## Document Revision History

Revision	Date	Description	Changed by
0	10/30/2008	Initial Release	-
1	10/6/2009	User Guide Reformat	BE
2	11/2/2009	Block Diagram Revision	BE
3	11/25/2009	Optical/backlight revised	BE
4	12/29/2009	Optical revised	BE

## Functions and Features

- 2 lines x 8 characters
- Built-in controller (SPLC780D or equivalent)
- 1/16 duty, 1/5 bias
- RoHS compliant

# Mechanical Drawing

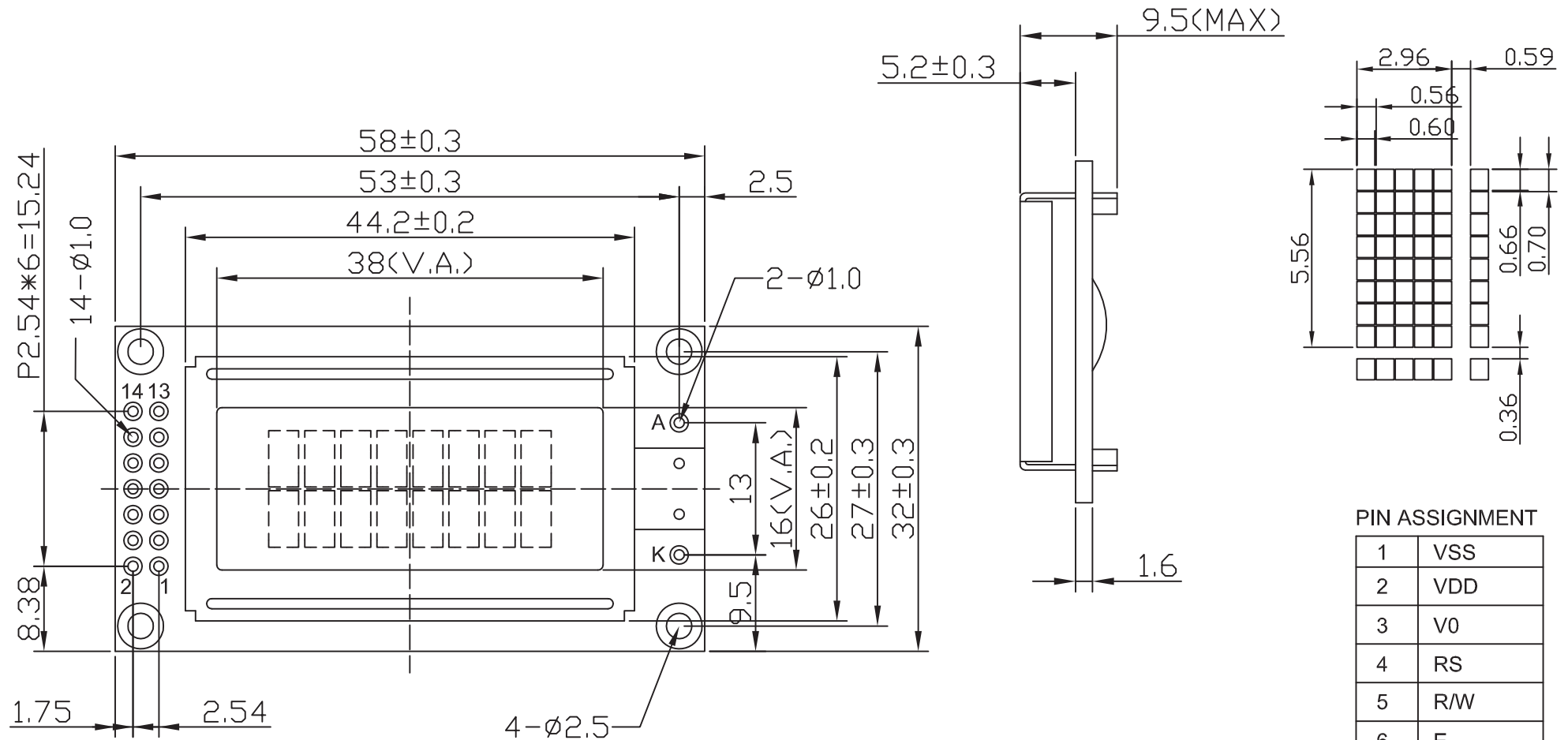

## PIN ASSIGNMENT

1	VSS
2	VDD
3	V0
4	RS
5	R/W
6	E
7~10	DB0~DB3
11~14	DB4~DB7
A	NC
K	NC

### Notes:

- 1). Driver Method: 1/16duty, 1/5bias, VDD5.0V VLCD4.4V
- 2). Display Type: STN-Yellow Green/Positive/Reflective/6:00 View
- 3). Operating Temp: -20°C~70°C/Storage Temp: -30°C~80°C
- 4). Driver: SPLC780D/4bit or 8bit MPU
- 5). RoHS Compliant

## Newhaven Display

Part No.

NHD-0208BZ-RN-YBW

## Pin Description and Wiring Diagram

Pin No.	Symbol	External Connection	Function Description
1	VSS	Power Supply	Ground
2	VDD	Power Supply	Supply Voltage for logic (+5.0V)
3	VO	Adj Power Supply	Power supply for contrast (approx. 0.6V)
4	RS	MPU	Register select signal. RS=0: Command, RS=1: Data
5	R/W	MPU	Read/Write select signal, R/W=1: Read R/W=0: Write
6	E	MPU	Operation enable signal. Falling edge triggered.
7-10	DB0 – DB3	MPU	Four low order bi-directional three-state data bus lines. These four are not used during 4-bit operation.
11-14	DB4 – DB7	MPU	Four high order bi-directional three-state data bus lines.
A	LED+	Power Supply	Power supply for LED Backlight (+4.2V)
K	LED-	Power Supply	Ground for Backlight

Recommended LCD connector: 2.54mm pitch pins

Backlight connector: --- Mates with: ---

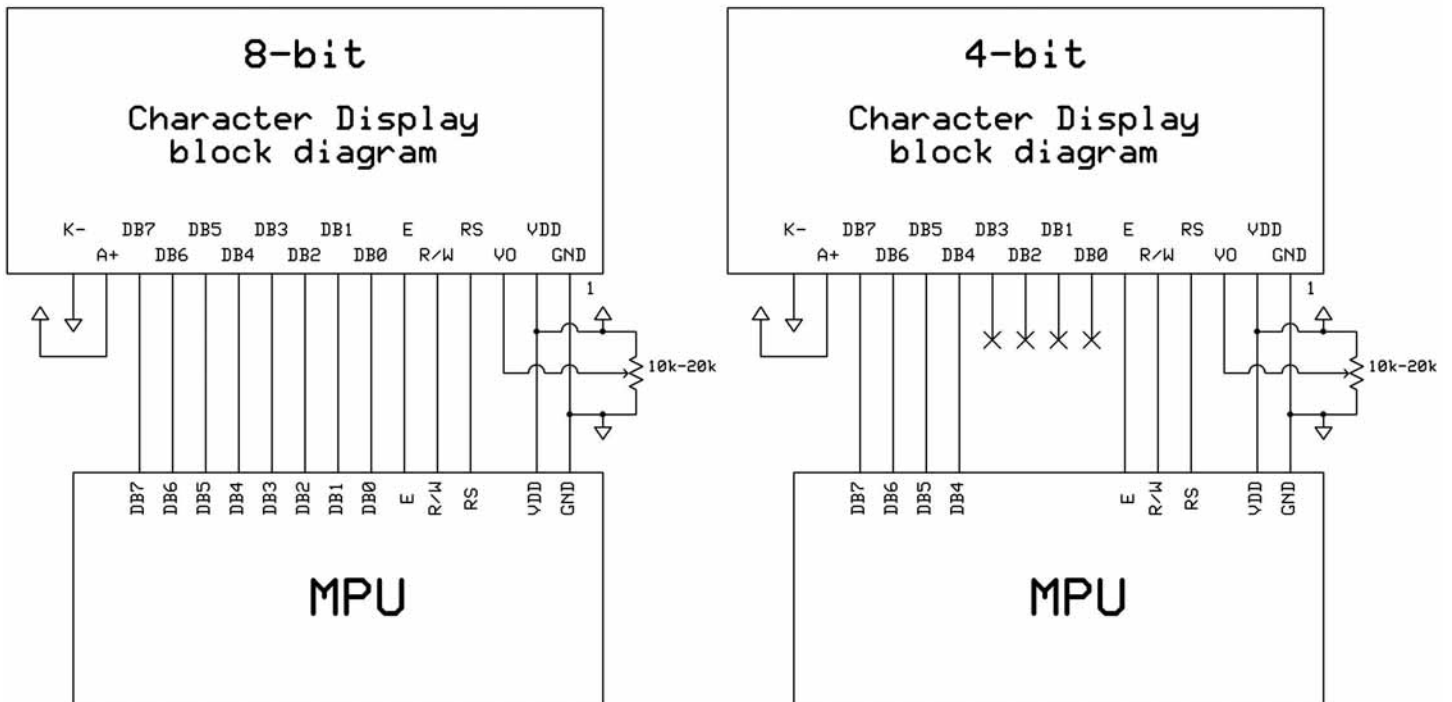

## Electrical Characteristics

Item	Symbol	Condition	Min.	Typ.	Max.	Unit
Operating Temperature Range	Top	Absolute Max	-20	-	+70	°C
Storage Temperature Range	Tst	Absolute Max	-30	-	+80	°C
Supply Voltage	VDD		4.7	5.0	5.5	V
Supply Current	IDD	Ta=25°C, VDD=5.0V	-	1.0	1.5	mA
Supply for LCD (contrast)	VDD-V0	Ta=25°C	-	4.4	-	V
"H" Level input	Vih		2.2	-	VDD	V
"L" Level input	Vil		0	-	0.6	V
"H" Level output	Voh		2.4	-	-	V
"L" Level output	Vol		-	-	0.4	V
Backlight Supply Voltage	Vled	-	-	4.2	-	V
Backlight Supply Current	Iled	Vled=4.2V	-	70	80	mA

## Optical Characteristics

Item	Symbol	Condition	Min.	Typ.	Max.	Unit
Viewing Angle - Vertical (top)	AV	Cr ≥ 2	-	25	-	°
Viewing Angle - Vertical (bottom)	AV	Cr ≥ 2	-	70	-	°
Viewing Angle - Horizontal (left)	AH	Cr ≥ 2	-	30	-	°
Viewing Angle - Horizontal (right)	AH	Cr ≥ 2	-	30	-	°
Contrast Ratio	Cr		-	2	-	-
Response Time (rise)	Tr	-	-	120	150	ms
Response Time (fall)	Tf	-	-	120	150	ms

## Controller Information

Built-in SPLC780D. Download specification at [http://www.newhavendisplay.com/app\\_notes/SPLC780D.pdf](http://www.newhavendisplay.com/app_notes/SPLC780D.pdf)

## Table of Commands

Instruction	Instruction Code										Description	Execution time (fosc= 270 kHz)
	RS	R/W	DB7	DB6	DB5	DB4	DB3	DB2	DB1	DB0		
Clear Display	0	0	0	0	0	0	0	0	0	1	Write "20H" to DDRAM and set DDRAM address to "00H" from AC	1.53 ms
Return Home	0	0	0	0	0	0	0	0	1	-	Set DDRAM address to "00H" from AC and return cursor to its original position if shifted. The contents of DDRAM are not changed.	1.53 ms
Entry Mode Set	0	0	0	0	0	0	0	1	I/D	SH	Assign cursor moving direction and enable the shift of entire display.	39 μs
Display ON/OFF Control	0	0	0	0	0	0	1	D	C	B	Set display(D), cursor(C), and blinking of cursor(B) on/off control bit.	39 μs
Cursor or Display Shift	0	0	0	0	0	1	S/C	R/L	-	-	Set cursor moving and display shift control bit, and the direction, without changing of DDRAM data.	39 μs
Function Set	0	0	0	0	1	DL	N	F	-	-	Set interface data length (DL: 8-bit/4-bit), numbers of display line (N: 2-line/1-line) and, display font type (F:5×11dots/5×8 dots)	39 μs
Set CGRAM Address	0	0	0	1	AC5	AC4	AC3	AC2	AC1	AC0	Set CGRAM address in address counter.	39 μs
Set DDRAM Address	0	0	1	AC6	AC5	AC4	AC3	AC2	AC1	AC0	Set DDRAM address in address counter.	39 μs
Read Busy Flag and Address	0	1	BF	AC6	AC5	AC4	AC3	AC2	AC1	AC0	Whether during internal operation or not can be known by reading BF. The contents of address counter can also be read.	0 μs
Write Data to RAM	1	0	D7	D6	D5	D4	D3	D2	D1	D0	Write data into internal RAM (DDRAM/CGRAM).	43 μs
Read Data from RAM	1	1	D7	D6	D5	D4	D3	D2	D1	D0	Read data from internal RAM (DDRAM/CGRAM).	43 μs

DDRAM address:

Display position

1	2	3	4	5	6	7	8
00	01	02	03	04	05	06	07
40	41	42	43	44	45	46	47

DDRAM address

## Timing Characteristics

### 6.5.3. Write mode (Writing Data from MPU to SPLC780D)

Characteristics	Symbol	Limit			Unit	Test Condition
		Min.	Typ.	Max.		
E Cycle Time	$t_c$	500	-	-	ns	Pin E
E Pulse Width	$t_{PW}$	230	-	-	ns	Pin E
E Rise/Fall Time	$t_r, t_f$	-	-	20	ns	Pin E
Address Setup Time	$t_{SP1}$	40	-	-	ns	Pins: RS, R/W, E
Address Hold Time	$t_{HD1}$	10	-	-	ns	Pins: RS, R/W, E
Data Setup Time	$t_{SP2}$	80	-	-	ns	Pins: DB0 - DB7
Data Hold Time	$t_{HD2}$	10	-	-	ns	Pins: DB0 - DB7

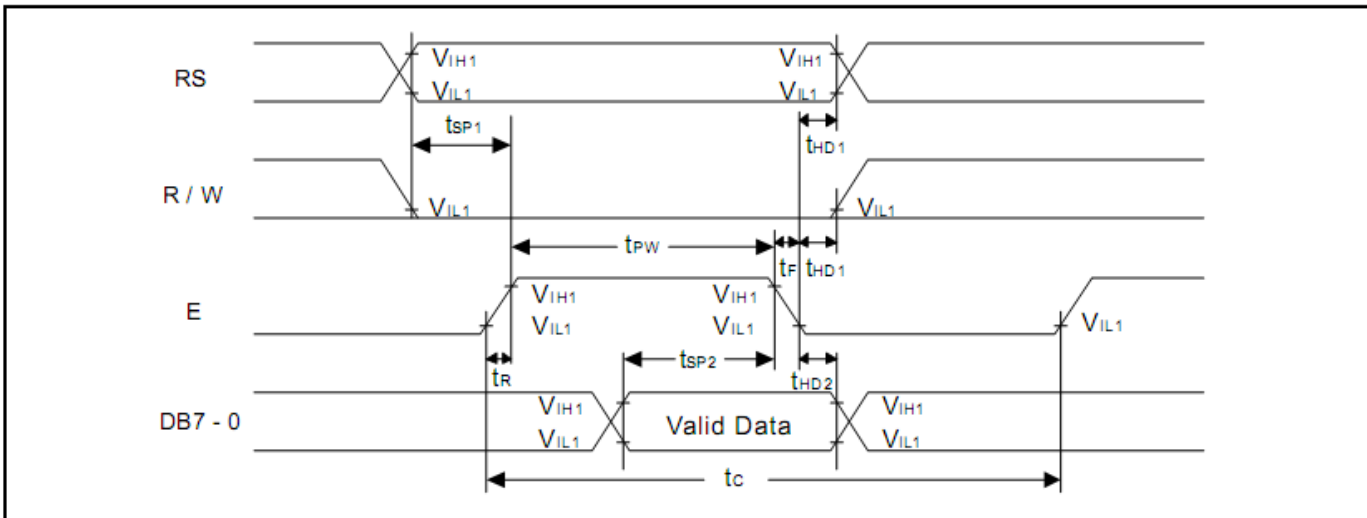

### 6.5.4. Read mode (Reading Data from SPLC780D to MPU)

Characteristics	Symbol	Limit			Unit	Test Condition
		Min.	Typ.	Max.		
E Cycle Time	$t_c$	500	-	-	ns	Pin E
E Pulse Width	$t_w$	230	-	-	ns	Pin E
E Rise/Fall Time	$t_r, t_f$	-	-	20	ns	Pin E
Address Setup Time	$t_{SP1}$	40	-	-	ns	Pins: RS, R/W, E
Address Hold Time	$t_{HD1}$	10	-	-	ns	Pins: RS, R/W, E
Data Output Delay Time	$t_D$	-	-	120	ns	Pins: DB0 - DB7
Data hold time	$t_{HD2}$	5.0	-	-	ns	Pin DB0 - DB7

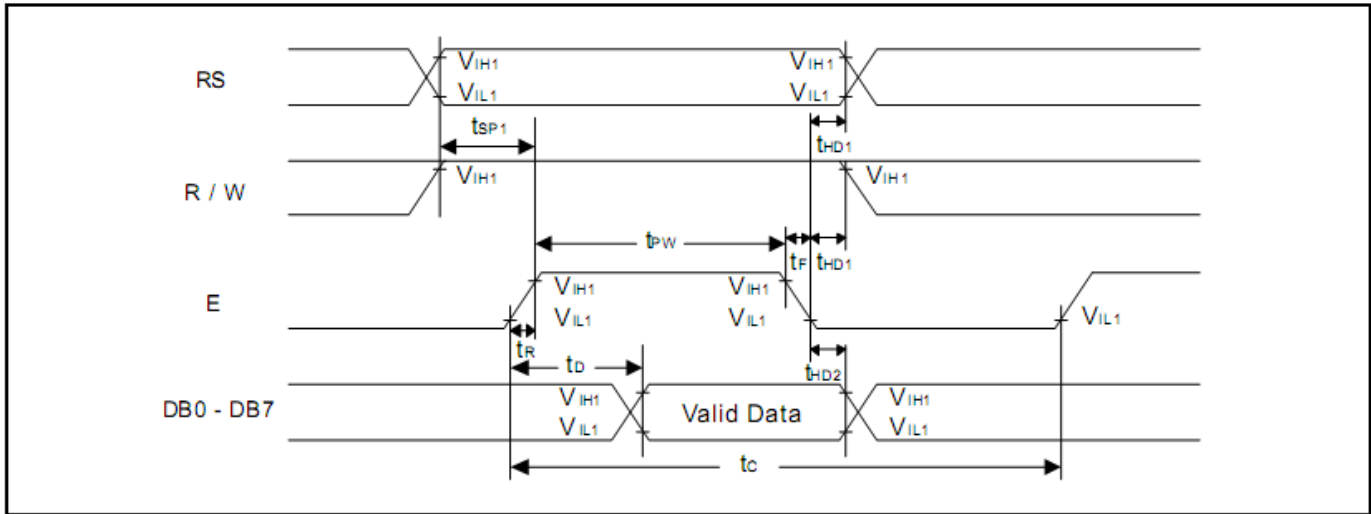

## Built-in Font Table



Lower 4 Bits	Upper 4 Bits	0000	0001	0010	0011	0100	0101	0110	0111	1000	1001	1010	1011	1100	1101	1110	1111
xxxx0000	CG RAM (1)			0	a	P	`	P				-	タ	ミ	&	P	
xxxx0001	(2)			!	1	A	Q	a	q			。	ア	チ	△	ä	q
xxxx0010	(3)			"	2	B	R	b	r			「	イ	ツ	×	ß	θ
xxxx0011	(4)			#	3	C	S	c	s			」	ウ	テ	モ	ε	8
xxxx0100	(5)			\$	4	D	T	d	t			、	エ	ト	ト	μ	Ω
xxxx0101	(6)			%	5	E	U	e	u			・	オ	ナ	1	ø	ü
xxxx0110	(7)			&	6	F	V	f	v			ヲ	カ	ニ	ヨ	ρ	Σ
xxxx0111	(8)			'	7	G	W	g	w			ヲ	キ	ヌ	ラ	g	π
xxxx1000	(1)			(	8	H	X	h	x			イ	ク	ネ	リ	√	∞
xxxx1001	(2)			)	9	I	Y	i	y			ウ	ケ	ノ	ル	'	γ
xxxx1010	(3)			*	:	J	Z	j	z			エ	コ	ハ	レ	j	κ
xxxx1011	(4)			+	;	K	[	k	[			オ	サ	ヒ	ロ	*	π
xxxx1100	(5)			,	<	L	¥	l	l			カ	シ	フ	ク	φ	π
xxxx1101	(6)			-	=	M	]	m	)			ユ	ス	ハ	ン	も	÷
xxxx1110	(7)			.	>	N	^	n	→			ヨ	セ	ホ	°	ñ	
xxxx1111	(8)			/	?	O	_	o	←			ツ	リ	マ	°	ö	■

## Example Initialization Program

8-bit Initialization:

```

/*****/
void command(char i)
{
    P1 = i;                //put data on output Port
    D_I =0;                //D/I=LOW : send instruction
    R_W =0;                //R/W=LOW : Write
    E = 1;
    Delay(1);              //enable pulse width >= 300ns
    E = 0;                 //Clock enable: falling edge
}
/*****/
void write(char i)
{
    P1 = i;                //put data on output Port
    D_I =1;                //D/I=LOW : send data
    R_W =0;                //R/W=LOW : Write
    E = 1;
    Delay(1);              //enable pulse width >= 300ns
    E = 0;                 //Clock enable: falling edge
}
/*****/
void init()
{
    E = 0;
    Delay(100);            //Wait >15 msec after power is applied
    command(0x30);         //command 0x30 = Wake up
    Delay(30);             //must wait 5ms, busy flag not available
    command(0x30);         //command 0x30 = Wake up #2
    Delay(10);             //must wait 160us, busy flag not available
    command(0x30);         //command 0x30 = Wake up #3
    Delay(10);             //must wait 160us, busy flag not available
    command(0x38);         //Function set: 8-bit/2-line
    command(0x10);         //Set cursor
    command(0x0c);         //Display ON; Cursor ON
    command(0x06);         //Entry mode set
}
/*****/
```

```

4-bit Initialization:
/*****/
void command(char i)
{
    P1 = i;                //put data on output Port
    D_I =0;                //D/I=LOW : send instruction
    R_W =0;                //R/W=LOW : Write
    Nybble();              //Send lower 4 bits
    i = i<<4;              //Shift over by 4 bits
    P1 = i;                //put data on output Port
    Nybble();              //Send upper 4 bits
}
/*****/
void write(char i)
{
    P1 = i;                //put data on output Port
    D_I =1;                //D/I=HIGH : send data
    R_W =0;                //R/W=LOW : Write
    Nybble();              //Clock lower 4 bits
    i = i<<4;              //Shift over by 4 bits
    P1 = i;                //put data on output Port
    Nybble();              //Clock upper 4 bits
}
/*****/
void Nybble()
{
    E = 1;
    Delay(1);              //enable pulse width >= 300ns
    E = 0;                 //Clock enable: falling edge
}
/*****/
void init()
{
    P1 = 0;
    P3 = 0;
    Delay(100);            //Wait >15 msec after power is applied
    P1 = 0x30;             //put 0x30 on the output port
    Delay(30);             //must wait 5ms, busy flag not available
    Nybble();              //command 0x30 = Wake up
    Delay(10);             //must wait 160us, busy flag not available
    Nybble();              //command 0x30 = Wake up #2
    Delay(10);             //must wait 160us, busy flag not available
    Nybble();              //command 0x30 = Wake up #3
    Delay(10);             //can check busy flag now instead of delay
    P1= 0x20;              //put 0x20 on the output port
    Nybble();              //Function set: 4-bit interface
    command(0x28);         //Function set: 4-bit/2-line
    command(0x10);         //Set cursor
    command(0x0F);         //Display ON; Blinking cursor
    command(0x06);         //Entry Mode set
}
/*****/

```

## Quality Information

Test Item	Content of Test	Test Condition	Note
High Temperature storage	Endurance test applying the high storage temperature for a long time.	+80°C , 48hrs	2
Low Temperature storage	Endurance test applying the low storage temperature for a long time.	-30°C , 48hrs	1,2
High Temperature Operation	Endurance test applying the electric stress (voltage & current) and the high thermal stress for a long time.	+70°C 48hrs	2
Low Temperature Operation	Endurance test applying the electric stress (voltage & current) and the low thermal stress for a long time.	-20°C , 48hrs	1,2
High Temperature / Humidity Operation	Endurance test applying the electric stress (voltage & current) and the high thermal with high humidity stress for a long time.	+40°C , 90% RH , 48hrs	1,2
Thermal Shock resistance	Endurance test applying the electric stress (voltage & current) during a cycle of low and high thermal stress.	0°C,30min -> 25°C,5min -> 50°C,30min = 1 cycle 10 cycles	
Vibration test	Endurance test applying vibration to simulate transportation and use.	10-55Hz , 15mm amplitude. 60 sec in each of 3 directions X,Y,Z For 15 minutes	3
Static electricity test	Endurance test applying electric static discharge.	VS=800V, RS=1.5kΩ, CS=100pF One time	

**Note 1:** No condensation to be observed.

**Note 2:** Conducted after 4 hours of storage at 25°C, 0%RH.

**Note 3:** Test performed on product itself, not inside a container.

## Precautions for using LCDs/LCMs

See Precautions at [www.newhavendisplay.com/specs/precautions.pdf](http://www.newhavendisplay.com/specs/precautions.pdf)

## Warranty Information and Terms & Conditions

[http://www.newhavendisplay.com/index.php?main\\_page=terms](http://www.newhavendisplay.com/index.php?main_page=terms)