Features

- Current-controlled Output Current Source with 4 Input Channels
- LVDS/CMOS Compatible Inputs Channel 2, 3, and 4
- Two Selectable Outputs for Grounded Laser Diodes
- Output Current per Channel up to 350 mA
- Total Output Current up to 500 mA
- On-chip RF Oscillator
- Control of 2 Different Swings and Frequencies by Use of 4 External Resistors
- Oscillator Frequency Range from 200 MHz to 500 MHz
- Maximum Oscillator Current Amplitude 100 mApp
- Single 5 V Power Supply
- Small Pb-free QFN24 Package (4 mm × 4 mm)



Applications

- DVD-RAM/DVD-RW/DVD+RW with CD-RW Capability
- Recordable Optical Drives

Description

The ATR0840 is a laser diode driver designed to operate two differently grounded laser diodes for DVD-RW/+RW (650 nm) and CD-RW (780 nm). The device includes four channels for four different optical power levels. The write channels (channel 2 to 4) can be controlled either by fast LVDS (Low Voltage Differential Signaling) or by single-ended standard CMOS logic. In case of single-ended use, each of the ENABLE inputs (NEx or Ex) can be used, the complementary input may be left open. There is no need for blocking or connection to a reference voltage.

The function of the read channel is to generate a continuous output current, channels 2 to 4 are designed as write channels with very fast switching speed. All channels are summed together and routed to one of the two outputs, IOUTA or IOUTB, controlled by the select input SELA. Each write channel (channels 2 to 4) can contribute up to 350 mA to the total output current of up to 500 mA. The read channel can contribute up to 150 mA. Total gain of 100 (read channel) and 250 (channel 2, 3 and 4), respectively, are provided between each reference current input and the selected output. Although the reference inputs are current inputs, voltage control is possible by using external resistors. An on-chip RF oscillator is available to reduce laser-mode hopping noise during read mode. The oscillator current amplitude can be set independently for the two selectable outputs with two different resistors. Oscillation is enabled by a high signal at the ENOSC pin. Complete shut-down of the output currents is achieved by a low signal at the ENABLE input.

In case of uncertain (balanced) enable signals, a built-in protection circuit keeps the laser diode output current within the defined range.



4 Channel Laser Driver with 2 Outputs and 3 LVDS Inputs

ATR0840

Summary

Figure 1. Block Diagram

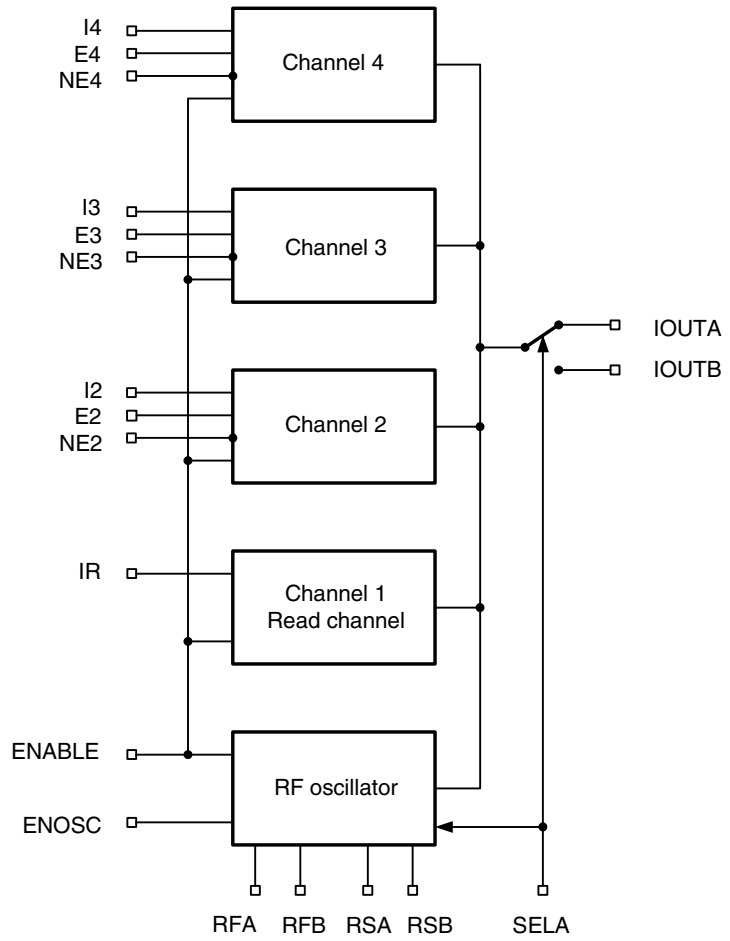

Pin Configuration

Figure 2. Pinning QFN24

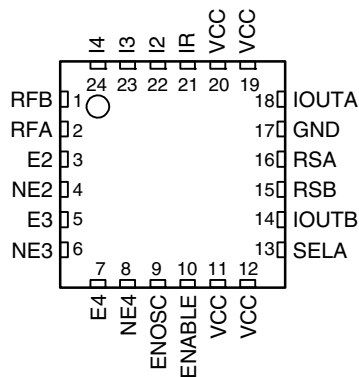

Pin Description

Pin	Symbol	Type	Function
1	RFB	Analog	External resistor to ground sets frequency of oscillator B
2	RFA	Analog	External resistor to ground sets frequency of oscillator A
3	E2	Digital	Digital control of channel 2 (high active)
4	NE2	Digital	Digital control of channel 2 (low active)
5	E3	Digital	Digital control of channel 3 (high active)
6	NE3	Digital	Digital control of channel 3 (low active)
7	E4	Digital	Digital control of channel 4 (high active)
8	NE4	Digital	Digital control of channel 4 (low active)
9	ENOSC	Digital	Enables RF oscillator (high active)
10	ENABLE	Digital	Enables output current (high active)
11	VCC	Supply	+5 V power supply
12	VCC	Supply	+5 V power supply
13	SELA	Digital	High: selects IOUTA, RSA, RFA Low: selects IOUTB, RSB, RFA
14	IOUTB	Analog	Output current source B for laser diode
15	RSB	Analog	External resistor to ground sets swing of oscillator B
16	RSA	Analog	External resistor to ground sets swing of oscillator A
17	GND	Supply	Ground
18	IOUTA	Analog	Output current source A for laser diode
19	VCC	Supply	+5 V power supply
20	VCC	Supply	+5 V power supply
21	IR	Analog	Reference current input read channel (input impedance 500 Ω to ground)
22	I2	Analog	Reference current input channel 2 (input impedance 500 Ω to ground)
23	I3	Analog	Reference current input channel 3 (input impedance 500 Ω to ground)
24	I4	Analog	Reference current input channel 4 (input impedance 500 Ω to ground)
Paddle	GND	Supply	Ground

Absolute Maximum Ratings

Stresses beyond those listed under “Absolute Maximum Ratings” may cause permanent damage to the device. This is a stress rating only and functional operation of the device at these or any other conditions beyond those indicated in the operational sections of this specification is not implied. Exposure to absolute maximum rating conditions for extended periods may affect device reliability.

Parameters	Symbol	Value	Unit
Supply voltage	V_{CC}	-0.5 to +6.1	V
Input voltage at any input	V_{in}	-0.5 to $V_{CC} + 0.5$	V
Power dissipation	P_{max}	0.7 ⁽¹⁾ to 1 ⁽²⁾	W
Output voltage	V_{out}	-0.5 to $V_{CC} - 1$	V
Junction temperature	T_j	150	°C
Storage temperature	T_{stg}	-65 to +125	°C

- Notes: 1. $R_{thJA} \leq 115$ K/W at $T_{amb} = 70^\circ\text{C}$
 2. $R_{thJA} \geq 115$ K/W at $T_{amb} = 25^\circ\text{C}$

Thermal Resistance

Parameters	Symbol	Value	Unit
Junction ambient, QFN24	R_{thJA}	50 ⁽¹⁾	K/W

- Note: 1. Measured with multi-layer test board (JEDEC standard)

Recommended Operating Range

Parameters	Symbol	Value	Unit
Supply voltage	V_{CC}	4.5 to 5.9	V
Input current	$I_{I1}, I_{I2}, I_{I3}, I_{I4}$	< 1.5	mA
External resistor to GND to set oscillator frequency	RFA, RFB	> 3	k Ω
External resistor to GND to set oscillator swing	RSA, RSB	> 1	k Ω
Operating temperature range	T_{amb}	0 to +70	°C

Ordering Information

Extended Type Number	Package	Remarks
ATR0840-PFQG	Lead free QFN24, 4 mm × 4 mm	Taped and reeled

Package Information

Package: QFN 24 - 4x4
 Exposed pad 2.1x2.1
 (acc. JEDEC OUTLINE No. MO-220)
 Dimensions in mm

Not indicated tolerances ±0.05

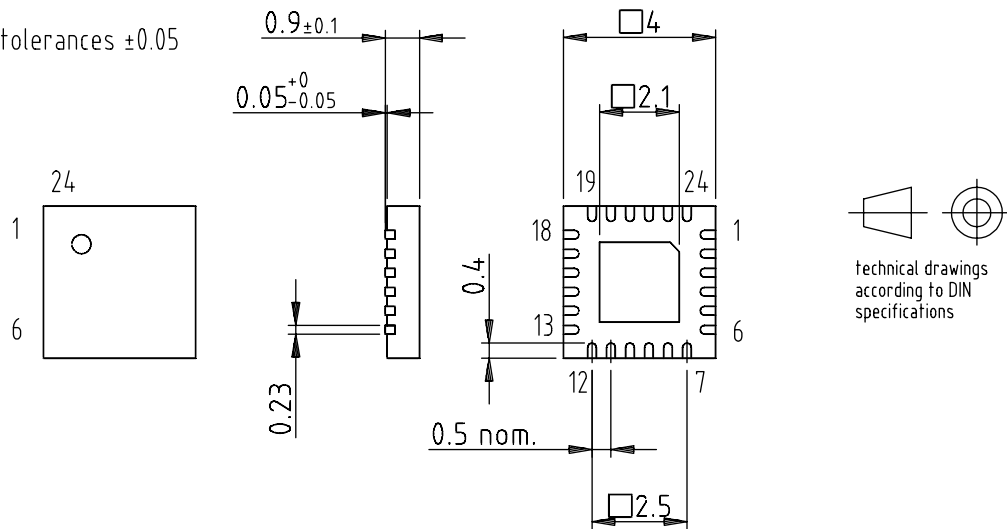

Drawing-No.: 6.543-5101.01-4
 Issue: 2; 16.06.03



Atmel Corporation

2325 Orchard Parkway
San Jose, CA 95131, USA
Tel: 1(408) 441-0311
Fax: 1(408) 487-2600

Regional Headquarters

Europe

Atmel Sarl
Route des Arsenaux 41
Case Postale 80
CH-1705 Fribourg
Switzerland
Tel: (41) 26-426-5555
Fax: (41) 26-426-5500

Asia

Room 1219
Chinachem Golden Plaza
77 Mody Road Tsimshatsui
East Kowloon
Hong Kong
Tel: (852) 2721-9778
Fax: (852) 2722-1369

Japan

9F, Tonetsu Shinkawa Bldg.
1-24-8 Shinkawa
Chuo-ku, Tokyo 104-0033
Japan
Tel: (81) 3-3523-3551
Fax: (81) 3-3523-7581

Atmel Operations

Memory

2325 Orchard Parkway
San Jose, CA 95131, USA
Tel: 1(408) 441-0311
Fax: 1(408) 436-4314

Microcontrollers

2325 Orchard Parkway
San Jose, CA 95131, USA
Tel: 1(408) 441-0311
Fax: 1(408) 436-4314

La Chantrerie
BP 70602
44306 Nantes Cedex 3, France
Tel: (33) 2-40-18-18-18
Fax: (33) 2-40-18-19-60

ASIC/ASSP/Smart Cards

Zone Industrielle
13106 Rousset Cedex, France
Tel: (33) 4-42-53-60-00
Fax: (33) 4-42-53-60-01

1150 East Cheyenne Mtn. Blvd.
Colorado Springs, CO 80906, USA
Tel: 1(719) 576-3300
Fax: 1(719) 540-1759

Scottish Enterprise Technology Park
Maxwell Building
East Kilbride G75 0QR, Scotland
Tel: (44) 1355-803-000
Fax: (44) 1355-242-743

RF/Automotive

Theresienstrasse 2
Postfach 3535
74025 Heilbronn, Germany
Tel: (49) 71-31-67-0
Fax: (49) 71-31-67-2340

1150 East Cheyenne Mtn. Blvd.
Colorado Springs, CO 80906, USA
Tel: 1(719) 576-3300
Fax: 1(719) 540-1759

Biometrics/Imaging/Hi-Rel MPU/ High Speed Converters/RF Datacom

Avenue de Rochepleine
BP 123
38521 Saint-Egreve Cedex, France
Tel: (33) 4-76-58-30-00
Fax: (33) 4-76-58-34-80

Literature Requests

www.atmel.com/literature

Disclaimer: Atmel Corporation makes no warranty for the use of its products, other than those expressly contained in the Company's standard warranty which is detailed in Atmel's Terms and Conditions located on the Company's web site. The Company assumes no responsibility for any errors which may appear in this document, reserves the right to change devices or specifications detailed herein at any time without notice, and does not make any commitment to update the information contained herein. No licenses to patents or other intellectual property of Atmel are granted by the Company in connection with the sale of Atmel products, expressly or by implication. Atmel's products are not authorized for use as critical components in life support devices or systems.

© Atmel Corporation 2004. All rights reserved.

Atmel® and combinations thereof are the registered trademarks of Atmel Corporation or its subsidiaries.

Other terms and product names may be the trademarks of others.



Printed on recycled paper.

4815AS-DVD-09/04