

LCD Panel EMI Reduction IC

Features

- FCC approved method of EMI attenuation.
- Provides up to 20dB of EMI suppression.
- Generates a low EMI spread spectrum clock of the input frequency.
- Input frequency range: 30MHz to 100MHz.
- 3.3v Operating Voltage
- Optimized for VGA, SVGA, and higher resolution XGA LCD Panels.
- Internal loop filter minimizes external components and board space.
- Six selectable high spread ranges up to $\pm 2\%$.
- Two selectable modulation rates.
- SSON# control pin for spread spectrum enable and disable options.
- Low cycle-to-cycle jitter.
- Wide operating range.
- Low power CMOS design.
- Supports most mobile graphic accelerator specifications.
- Products available for automotive temperature range. (*Refer Spread Spectrum Range Selection Tables*)
- Available in 8-pin SOIC and TSSOP Packages.

Product Description

The P2040A is a versatile spread spectrum frequency

Block Diagram

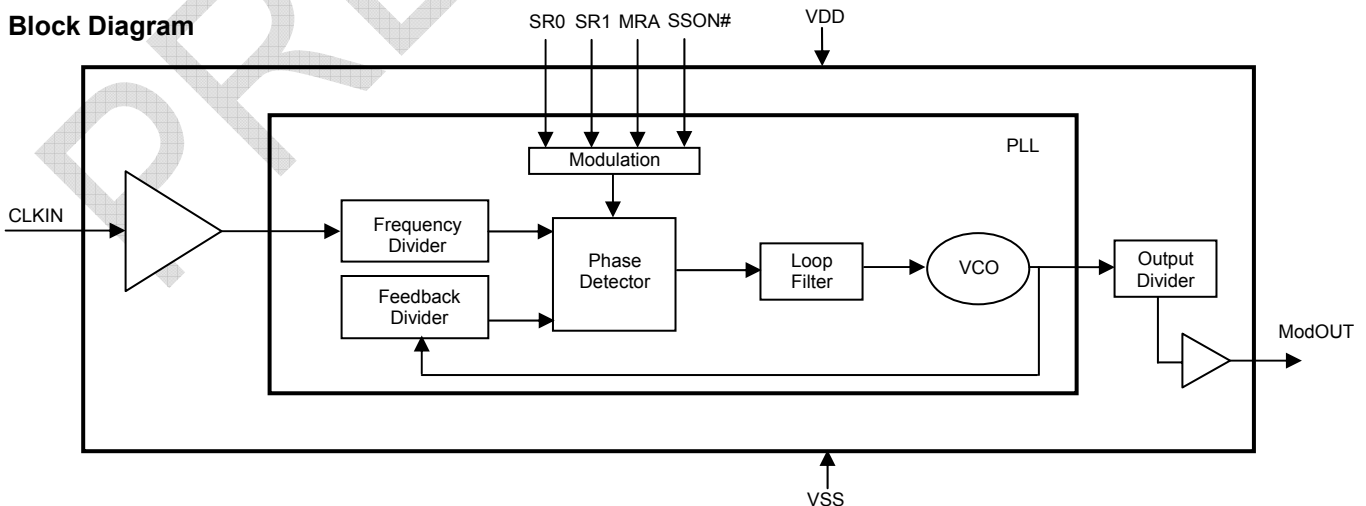

modulator designed specifically for digital flat panel applications. The P2040A reduces electromagnetic interference (EMI) at the clock source, allowing system wide reduction of EMI of down stream clock and data dependent signals. The P2040A allows significant system cost savings by reducing the number of circuit board layers ferrite beads, shielding and other passive components that are traditionally required to pass EMI regulations.

The P2040A uses the most efficient and optimized modulation profile approved by the FCC and is implemented in a proprietary all digital method.

The P2040A modulates the output of a single PLL in order to “spread” the bandwidth of a synthesized clock, and more importantly, decreases the peak amplitudes of its harmonics. This results in significantly lower system EMI compared to the typical narrow band signal produced by oscillators and most frequency generators. Lowering EMI by increasing a signal’s bandwidth is called ‘spread spectrum clock generation’.

Applications

The P2040A is targeted towards digital flat panel applications for notebook PCs, palm-size PCs, office automation equipments and LCD monitors.

rev 1.3

Pin Configuration

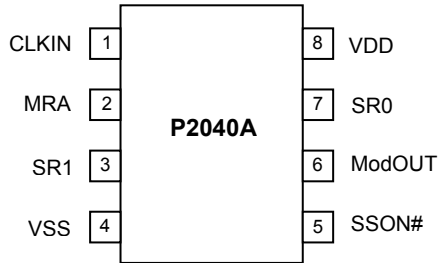

Pin Description

Pin#	Pin Name	Type	Description
1	CLKIN	I	External reference frequency input. Connect to externally generated reference signal.
2	MRA	I	Digital logic input used to select modulation rate. This pin has an internal pull-up resistor.
3	SR1	I	Digital logic input used to select Spreading Range. This pin has an internal pull-up resistor.
4	VSS	P	Ground to entire chip. Connect to system ground.
5	SSON#	I	Digital logic input used to enable Spread Spectrum function (Active LOW). Spread Spectrum function enabled when LOW, disabled when HIGH. This pin has an internal pull-low resistor.
6	ModOUT	O	Spread spectrum clock output.
7	SR0	I	Digital logic input used to select Spreading Range. This pin has an internal pull-up resistor.
8	VDD	P	Power supply for the entire chip (3.3V)

Modulation Selection (Commercial)

MRA	SR1	SR0	Spreading Range	Modulation Rate (KHz)
0	0	0	± 1.125	(FIN /40) * 34.72KHz
0	0	1	± 1.75	(FIN /40) * 34.72KHz
0	1	0	± 0.75	(FIN /40) * 34.72KHz
0	1	1	± 1.25	(FIN /40) * 34.72KHz
1	0	0	± 1.25	(FIN /40) * 20.83KHz
1	0	1	± 2.00	(FIN /40) * 20.83KHz
1	1	0	Reserved	Reserved
1	1	1	Reserved	Reserved

rev 1.3

Spread Range Selection at 50MHz (Automotive)

MRA	SR1	SR0	Spreading Range	Modulation Rate
0	0	0	± 1.25	(F _{IN} /40) * 34.72KHz
0	0	1	± 2.00	(F _{IN} /40) * 34.72KHz
0	1	0	± 1.00	(F _{IN} /40) * 34.72KHz
0	1	1	± 1.50	(F _{IN} /40) * 34.72KHz
1	0	0	± 1.25	(F _{IN} /40) * 20.83KHz
1	0	1	± 2.00	(F _{IN} /40) * 20.83KHz
1	1	0	± 1.25	(F _{IN} /40) * 20.83KHz
1	1	1	± 2.00	(F _{IN} /40) * 20.83KHz

Spread Range Selection at 70MHz (Automotive)

MRA	SR1	SR0	Spreading Range	Modulation Rate
0	0	0	± 1.00	(F _{IN} /40) * 34.72KHz
0	0	1	± 1.50	(F _{IN} /40) * 34.72KHz
0	1	0	± 0.70	(F _{IN} /40) * 34.72KHz
0	1	1	± 1.00	(F _{IN} /40) * 34.72KHz
1	0	0	± 1.15	(F _{IN} /40) * 20.83KHz
1	0	1	± 2.00	(F _{IN} /40) * 20.83KHz
1	1	0	± 1.15	(F _{IN} /40) * 20.83KHz
1	1	1	± 1.75	(F _{IN} /40) * 20.83KHz

rev 1.3

Spread Spectrum Selection

The *Modulation Selection Table* defines the possible spread spectrum options. The optimal setting should minimize system EMI to the fullest without affecting system performance. The spreading is described as a percentage deviation of the center frequency. (Note: The center frequency is the frequency of the external reference input on CLKIN, pin1).

For example, P2040A is designed for high-resolution, flat panel applications and is able to support an XGA (1024 x 768) flat panel operating at 65MHz (F_{IN}) clock speed. A spreading selection of MRA=0, SR1=1 and SR0=0 provides a percentage deviation of $\pm 0.75\%$ from F_{IN} . This results in the frequency on ModOUT being swept from 64.51MHz to 65.49MHz at a modulation rate of 56.24KHz. Refer *Modulation Selection Table*. The example in the following illustration is a common EMI reduction method for a notebook LCD panel and has already been implemented by most of the leading OEM and mobile graphic accelerator manufacturers.

Application Schematic for Mobile LCD Graphics Controllers

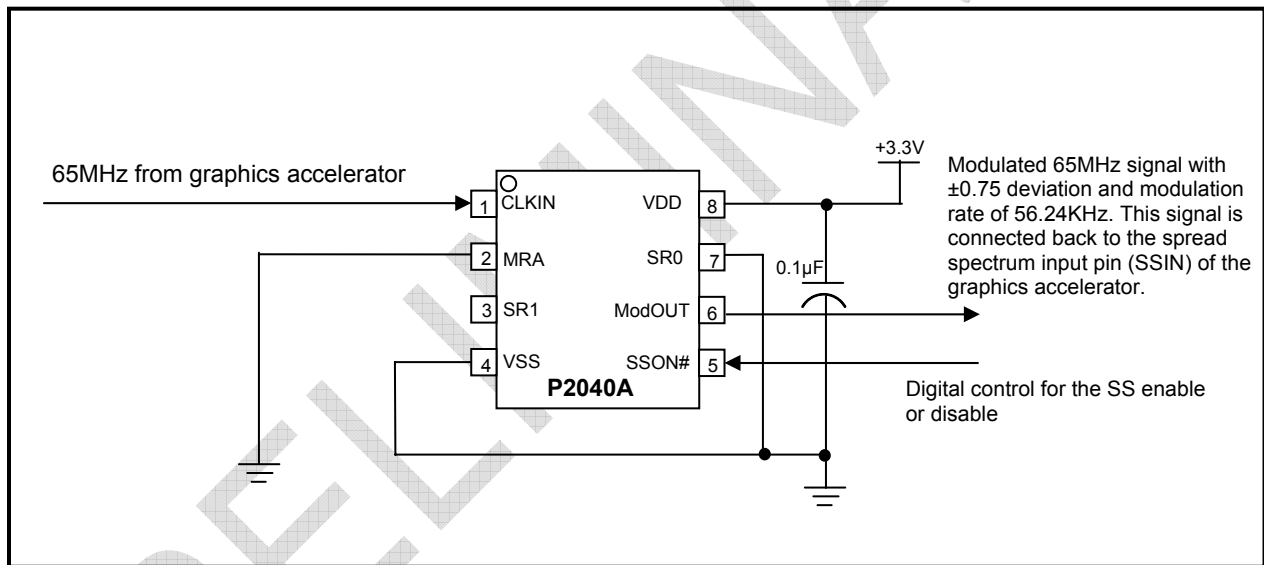

rev 1.3

Absolute Maximum Ratings

Symbol	Parameter	Rating	Unit
VDD, VIN	Voltage on any pin with respect to Ground	-0.5 to +4.6	V
T _{STG}	Storage temperature	-65 to +125	°C
T _A	Operating temperature	-40 to +125	°C
T _s	Max. Soldering Temperature (10 sec)	260	°C
T _J	Junction Temperature	150	°C
T _{DV}	Static Discharge Voltage (As per JEDEC STD22- A114-B)	2	KV

Note: These are stress ratings only and are not implied for functional use. Exposure to absolute maximum ratings for prolonged periods of time may affect device reliability.

DC Electrical Characteristics

(Test condition: All parameters are measured at room temperature (+25°C) unless otherwise stated)

Symbol	Parameter	Min	Typ	Max	Unit
V _{IL}	Input low voltage	VSS - 0.3	-	0.8	V
V _{IH}	Input high voltage	2.0	-	VDD + 0.3	V
I _{IL}	Input low current (pull-up resistor on inputs SR0, SR1 and MRA)	-35	-	-	µA
I _{IH}	Input high current (pull-down resistor on input SSON#)	-	-	35	µA
V _{OL}	Output low voltage (VDD = 3.3V, I _{OL} = 20mA)	-	-	0.4	V
V _{OH}	Output high voltage (VDD = 3.3V, I _{OH} = 20mA)	2.5	-	-	V
I _{DD}	Static supply current standby mode	-	0.6	-	mA
I _{CC}	Dynamic supply current (3.3V and 10pF loading)	7	10	13	mA
VDD	Operating voltage	2.7	3.3	3.7	V
t _{ON}	Power-up time (first locked cycle after power up)	-	0.18	-	mS
Z _{OUT}	Clock output impedance	-	50	-	Ω

AC Electrical Characteristics

Symbol	Parameter	Min	Typ	Max	Unit
f _{IN}	Input frequency	30	-	100	MHz
f _{OUT}	Output frequency	30	-	100	MHz
t _{LH} *	Output rise time (measured at 0.8V to 2.0V)	0.7	0.9	1.1	nS
t _{HL} *	Output fall time (measured at 2.0V to 0.8V)	0.6	0.8	1.0	nS
t _{JC}	Jitter (cycle to cycle)	-	-	360	pS
t _D	Output duty cycle	45	50	55	%

*t_{LH} and t_{HL} are measured into a capacitive load of 15pF

rev 1.3

Package Information

8-lead (150-mil) SOIC Package

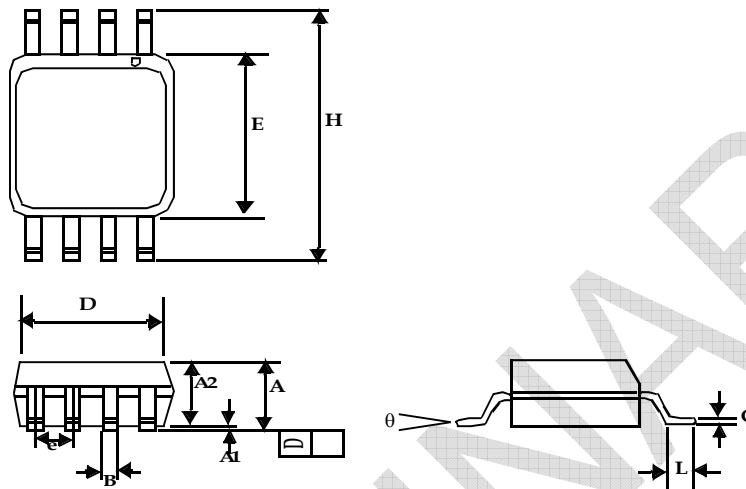

Symbol	Dimensions			
	Inches		Millimeters	
	Min	Max	Min	Max
A1	0.004	0.010	0.10	0.25
A	0.053	0.069	1.35	1.75
A2	0.049	0.059	1.25	1.50
B	0.012	0.020	0.31	0.51
C	0.007	0.010	0.18	0.25
D	0.193 BSC		4.90 BSC	
E	0.154 BSC		3.91 BSC	
e	0.050 BSC		1.27 BSC	
H	0.236 BSC		6.00 BSC	
L	0.016	0.050	0.41	1.27
theta	0°	8°	0°	8°

8-lead TSSOP (4.40-MM Body)

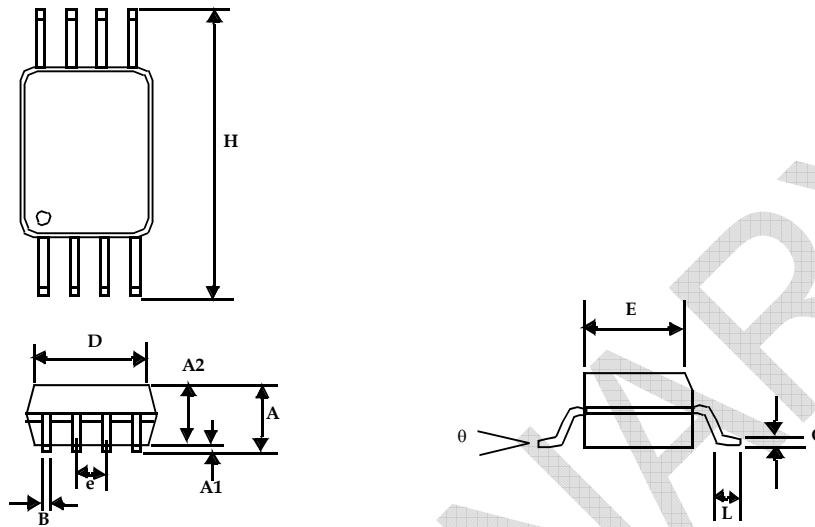

Symbol	Dimensions			
	Inches		Millimeters	
	Min	Max	Min	Max
A		0.043		1.10
A1	0.002	0.006	0.05	0.15
A2	0.033	0.037	0.85	0.95
B	0.008	0.012	0.19	0.30
c	0.004	0.008	0.09	0.20
D	0.114	0.122	2.90	3.10
E	0.169	0.177	4.30	4.50
e	0.026 BSC		0.65 BSC	
H	0.252 BSC		6.40 BSC	
L	0.020	0.028	0.50	0.70
theta	0°	8°	0°	8°

rev 1.3

Ordering Information

Part number	Marking	Package Type	Temperature
P2040AF-08-ST	P2040AF	8-Pin SOIC, Tube, Pb Free	Commercial
P2040AF-08-SR	P2040AF	8-Pin SOIC, Tape and Reel, Pb Free	Commercial
P2040AF-08-TT	P2040AF	8-Pin TSSOP, Tube, Pb Free	Commercial
P2040AF-08-TR	P2040AF	8-Pin TSSOP, Tape and Reel, Pb Free	Commercial
P2040AG-08-ST	P2040AG	8-Pin SOIC, Tube, Green	Commercial
P2040AG-08-SR	P2040AG	8-Pin SOIC, Tape and Reel, Green	Commercial
P2040AG-08-TT	P2040AG	8-Pin TSSOP, Tube, Green	Commercial
P2040AG-08-TR	P2040AG	8-Pin TSSOP, Tape and Reel, Green	Commercial
I2040AF-08-ST	I2040AF	8-Pin SOIC, Tube, Pb Free	Industrial
I2040AF-08-SR	I2040AF	8-Pin SOIC, Tape and Reel, Pb Free	Industrial
I2040AF-08-TT	I2040AF	8-Pin TSSOP, Tube, Pb Free	Industrial
I2040AF-08-TR	I2040AF	8-Pin TSSOP, Tape and Reel, Pb Free	Industrial
I2040AG-08-ST	I2040AG	8-Pin SOIC, Tube, Green	Industrial
I2040AG-08-SR	I2040AG	8-Pin SOIC, Tape and Reel, Green	Industrial
I2040AG-08-TT	I2040AG	8-Pin TSSOP, Tube, Green	Industrial
I2040AG-08-TR	I2040AG	8-Pin TSSOP, Tape and Reel, Green	Industrial
X2040AF-08-ST	I2040AF	8-Pin SOIC, Tube, Pb Free	Automotive
X2040AF-08-SR	I2040AF	8-Pin SOIC, Tape and Reel, Pb Free	Automotive
X2040AF-08-TT	I2040AF	8-Pin TSSOP, Tube, Pb Free	Automotive
X2040AF-08-TR	I2040AF	8-Pin TSSOP, Tape and Reel, Pb Free	Automotive
X2040AG-08-ST	I2040AG	8-Pin SOIC, Tube, Green	Automotive
X2040AG-08-SR	I2040AG	8-Pin SOIC, Tape and Reel, Green	Automotive
X2040AG-08-TT	I2040AG	8-Pin TSSOP, Tube, Green	Automotive
X2040AG-08-TR	I2040AG	8-Pin TSSOP, Tape and Reel, Green	Automotive

Device Ordering Information

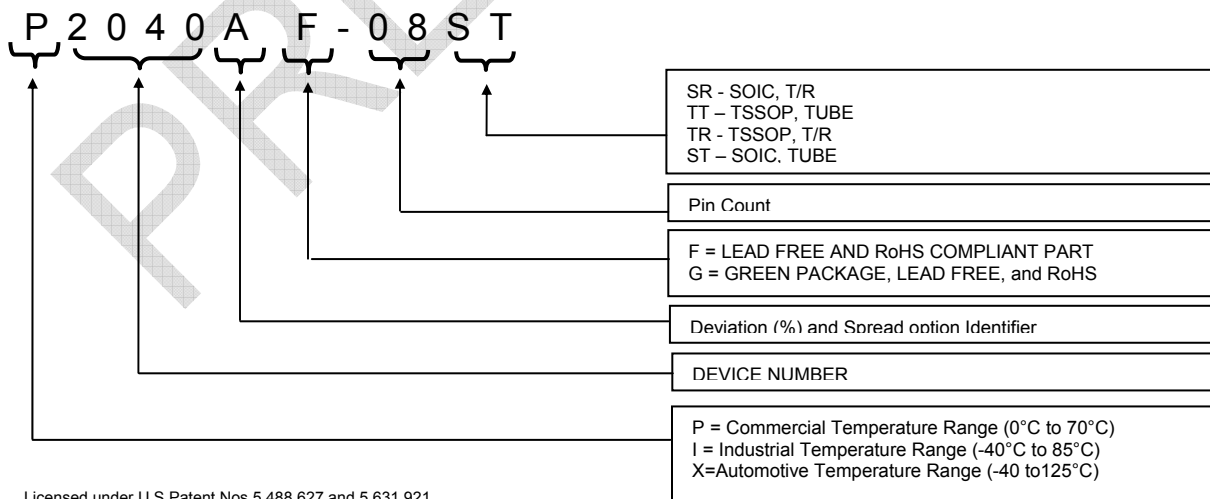

Licensed under U.S Patent Nos 5,488,627 and 5,631,921



PulseCore Semiconductor Corporation
1715 S. Bascom Ave Suite 200
Campbell, CA 95008
Tel: 408-879-9077
Fax: 408-879-9018
www.pulsecoresemi.com

Copyright © PulseCore Semiconductor
All Rights Reserved
Preliminary Information
Part Number: P2040A
Document Version: v1.3

Note: This product utilizes US Patent # 6,646,463 Impedance Emulator Patent issued to PulseCore Semiconductor, dated 11-11-2003

© Copyright 2006 PulseCore Semiconductor Corporation. All rights reserved. Our logo and name are trademarks or registered trademarks of PulseCore Semiconductor. All other brand and product names may be the trademarks of their respective companies. PulseCore reserves the right to make changes to this document and its products at any time without notice. PulseCore assumes no responsibility for any errors that may appear in this document. The data contained herein represents PulseCore's best data and/or estimates at the time of issuance. PulseCore reserves the right to change or correct this data at any time, without notice. If the product described herein is under development, significant changes to these specifications are possible. The information in this product data sheet is intended to be general descriptive information for potential customers and users, and is not intended to operate as, or provide, any guarantee or warranty to any user or customer. PulseCore does not assume any responsibility or liability arising out of the application or use of any product described herein, and disclaims any express or implied warranties related to the sale and/or use of PulseCore products including liability or warranties related to fitness for a particular purpose, merchantability, or infringement of any intellectual property rights, except as express agreed to in PulseCore's Terms and Conditions of Sale (which are available from PulseCore). All sales of PulseCore products are made exclusively according to PulseCore's Terms and Conditions of Sale. The purchase of products from PulseCore does not convey a license under any patent rights, copyrights; mask works rights, trademarks, or any other intellectual property rights of PulseCore or third parties. PulseCore does not authorize its products for use as critical components in life-supporting systems where a malfunction or failure may reasonably be expected to result in significant injury to the user, and the inclusion of PulseCore products in such life-supporting systems implies that the manufacturer assumes all risk of such use and agrees to indemnify PulseCore against all claims arising from such use.