

3062 Series Relampable Incandescent Indicator Light

DESCRIPTION AND FEATURES

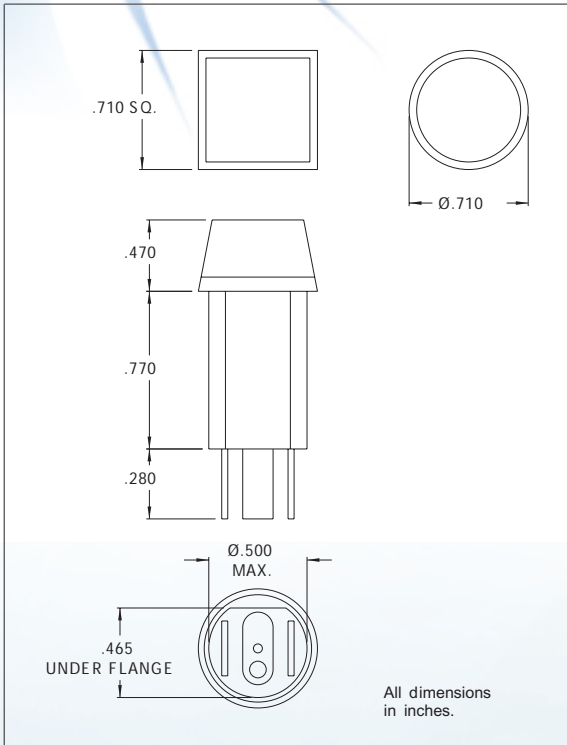

Ordering Information:
 For use with T-2 slide base (short) lamps.
 Complete assembly consists of socket (3062),
 lamp and lens (see chart below).
 Items supplied unassembled. Lamp lens and socket
 must be ordered separately.

Mounting: Ø.500 hole, supplied with push-on
 speednut SN0461
 Mounting hole pattern on page SP2.

Lens: Polycarbonate, snap-on

Body: Black Nylon

Terminals: Nickel plated brass

Lens Color Table		
Color	Round Lens No.	Square Lens No.
Red	3111	3121
Clear	3112	3122
Amber	3113	3123
White	3114	3124
Green	3115	3125
Blue	3116	3126
Yellow	3117	3127