



TO-251 Plastic-Encapsulate Transistors

D882 TRANSISTOR (NPN)

FEATURES

Power dissipation

$$P_{CM} : 1.25W (T_{amb}=25)$$

Collector current

$$I_{CM} : 3A$$

Collector-base voltage

$$V_{(BR)CBO} : 40V$$

Operating and storage junction temperature range

$$T_J , T_{stg} : -55 \text{ to } +150$$

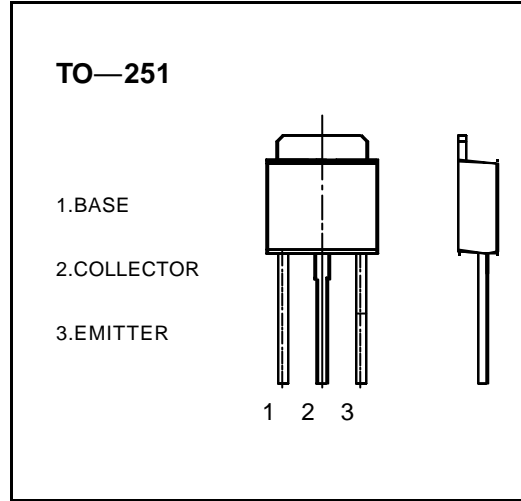

ELECTRICAL CHARACTERISTICS ($T_{amb}=25$ unless otherwise specified)

Parameter	Symbol	Test conditions	MIN	TYP	MAX	UNIT
Collector-base breakdown voltage	$V_{(BR)CBO}$	$I_C = 100 \mu A, I_E = 0$	40			V
Collector-emitter breakdown voltage	$V_{(BR)CEO}$	$I_C = 10 mA, I_B = 0$	30			V
Emitter-base breakdown voltage	$V_{(BR)EBO}$	$I_E = 100 \mu A, I_C = 0$	6			V
Collector cut-off current	I_{CBO}	$V_{CB} = 40 V, I_E = 0$			1	μA
Collector cut-off current	I_{CEO}	$V_{CE} = 30 V, I_B = 0$			10	μA
Emitter cut-off current	I_{EBO}	$V_{EB} = 6 V, I_C = 0$			1	μA
DC current gain	$h_{FE(1)}$	$V_{CE} = 2 V, I_C = 1 A$	60		400	
	$h_{FE(2)}$	$V_{CE} = 2 V, I_C = 100 mA$	32			
Collector-emitter saturation voltage	$V_{CE(sat)}$	$I_C = 2 A, I_B = 0.2 A$			0.5	V
Base-emitter saturation voltage	$V_{BE(sat)}$	$I_C = 2 A, I_B = 0.2 A$			1.5	V
Transition frequency	f_T	$V_{CE} = 5V, I_C = 0.1A$ $f = 10MHz$	50			MHz

CLASSIFICATION OF $h_{FE(1)}$

Rank	R	O	Y	GR
Range	60-120	100-200	160-320	200-400

Typical Characteristics

D882

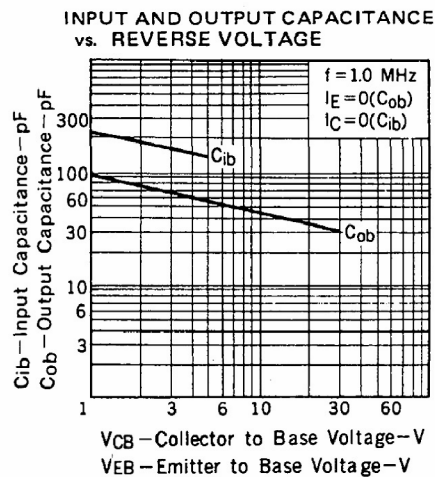
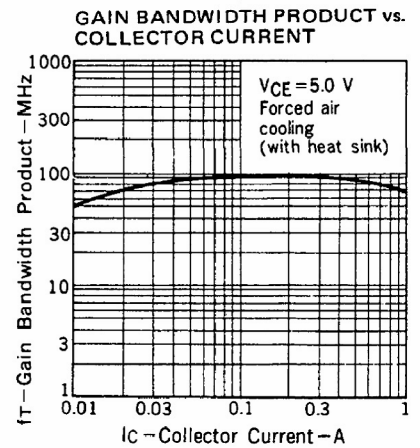
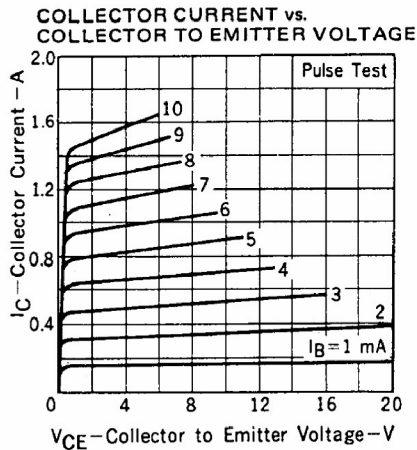
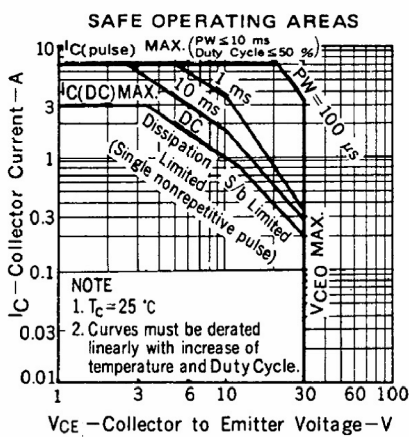
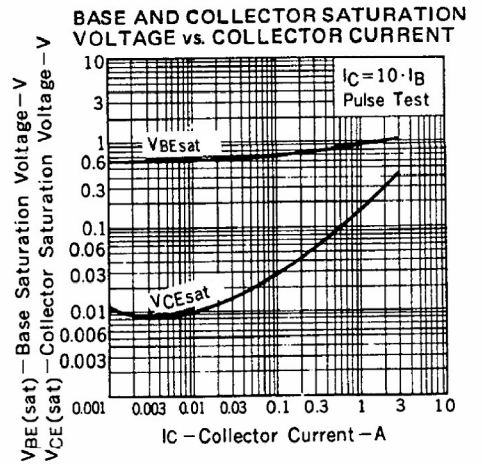
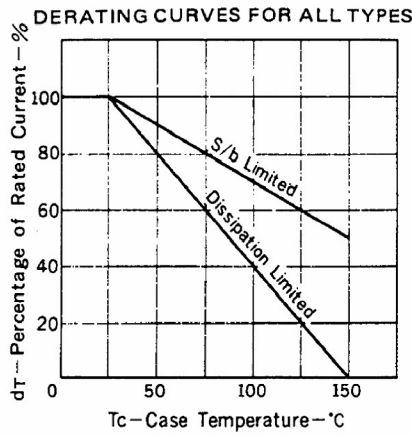
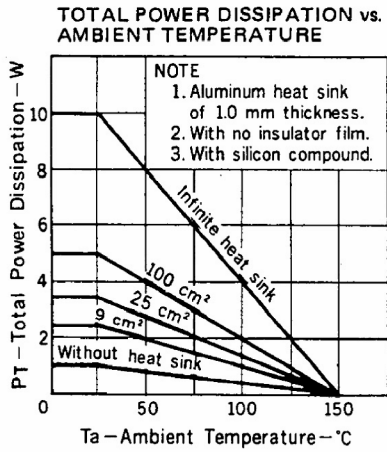

TO-251 PACKAGE OUTLINE DIMENSIONS

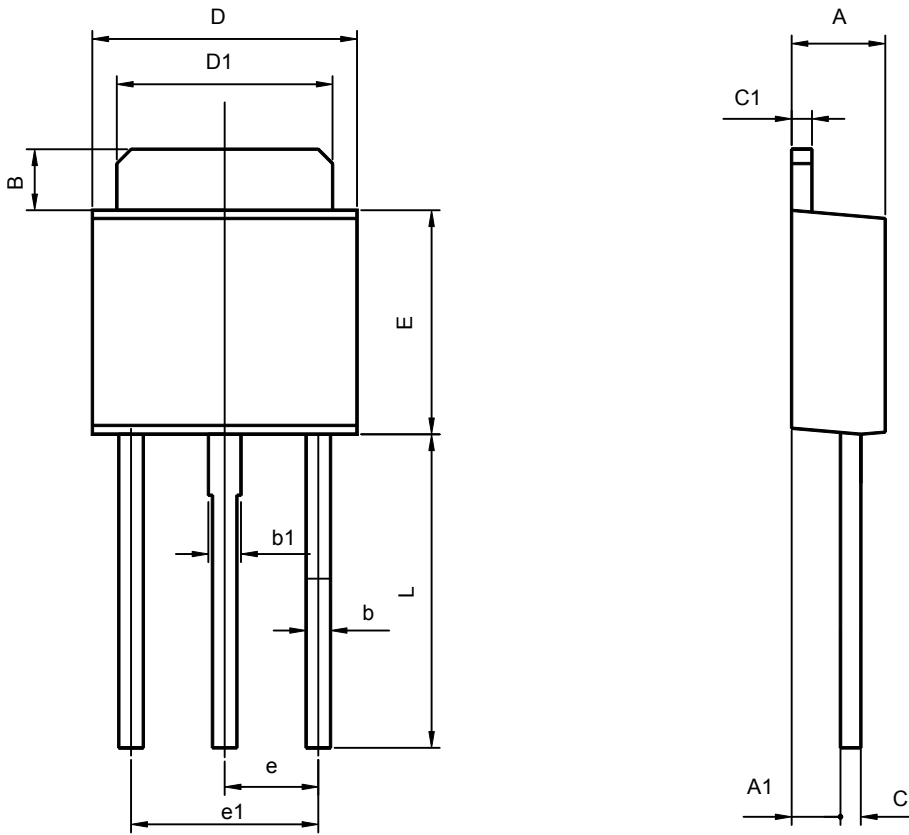

Symbol	Dimensions In Millimeters		Dimensions In Inches	
	Min	Max	Min	Max
A	2.200	2.400	0.087	0.094
A1	1.020	1.270	0.040	0.050
B	1.350	1.650	0.053	0.065
b	0.500	0.700	0.020	0.028
b1	0.700	0.900	0.028	0.035
c	0.430	0.580	0.017	0.023
c1	0.430	0.580	0.017	0.023
D	6.350	6.650	0.250	0.262
D1	5.200	5.400	0.205	0.213
E	5.400	5.700	0.213	0.224
e	2.300TYP		0.091TYP	
e1	4.500	4.700	0.177	0.185
L	7.500	7.900	0.295	0.311