

Data Sheet
INTEGRATED CIRCUIT
2002 Nov 08

OM1654A & OM1654

Simple zero-crossing triac control
circuit

INTEGRATED ELECTRONIC SOLUTIONS
1 BUTLER DRIVE
HENDON SA 5014
AUSTRALIA



Simple zero-crossing triac control circuit

OM1654A & OM1654**CONTENTS**

| | |
|--------|--|
| 1 | FEATURES |
| 2 | GENERAL DESCRIPTION |
| 3 | ORDERING INFORMATION |
| 4 | PINNING INFORMATION |
| 4.1 | Pinning layout (8 pin) |
| 4.2 | Pin description (8 pin) |
| 5 | BLOCK DIAGRAM |
| 6 | FUNCTIONAL DESCRIPTION |
| 6.1 | COM - Common, positive DC supply |
| 6.2 | SUBS - Substrate, negative DC supply |
| 6.3 | AC - AC signal, power supply and synchronisation |
| 6.4 | PWR - Power supply |
| 6.5 | G - Triac gate drive |
| 6.6 | CAP - Timing capacitor |
| 6.7 | SENS - Sensor input |
| 7 | LIMITING VALUES |
| 8 | CHARACTERISTICS |
| 9 | APPLICATION INFORMATION |
| 9.1 | Design considerations |
| 9.1.1 | Negative half cycle |
| 9.1.2 | Positive half cycle |
| 9.1.3 | Gate current |
| 9.1.4 | Temperature sensing |
| 9.2 | Application circuits |
| 10 | PACKAGE OUTLINES |
| 11 | SOLDERING |
| 11.1 | Introduction |
| 11.2 | DIP |
| 11.2.1 | Soldering by dipping or by wave |
| 11.2.2 | Repairing soldered joints |
| 11.3 | SO |
| 11.3.1 | Reflow soldering |
| 11.3.2 | Wave soldering |
| 11.3.3 | Repairing soldered joints |
| 12 | DEFINITIONS |
| 13 | IES INFORMATION |
| 14 | DISCLAIMER ⁽¹⁾ |

(1) The contents of this document are subject to the disclaimer on page 16

Simple zero-crossing triac control circuit

OM1654A & OM1654

1 FEATURES

- Low external component count
- Constant ON cycle time, with proportional OFF time
- All ON cycles consist of an integral number of mains cycles
- No DC component in the mains supply
- On chip circuit protection against triac gate spikes
- Low supply current requirement
- Sensor AC powered, thus minimising DC supply and filtering needs
- OM1654A has separate power supply input, allowing easy gate pulse width adjustment

2 GENERAL DESCRIPTION

The OM1654A (and OM1654) is a monolithic bipolar control circuit for zero-crossing triggering of a triac in applications where it is controlled by a resistive sensor such as an NTC (negative temperature coefficient) thermistor. In a typical application it can be used for the temperature control of a heating element in a cooker or another home heating appliance.

The OM1654A has an additional connected pin (PWR) for power supply input, allowing the pin AC to be independently driven for optimum gate pulse width setting.

The OM1654 may have PCB layouts which use the not connected pin 7 in the layout. In this case the OM1654A might not be able to be used in its place. If pin 7 is not used in the layout, either OM1654A or OM1654 can be used. OM1654A is the preferred type.

It is designed to control a suitable triac over an ambient of 0 to 100 degrees Celsius with a resistive load ranging from 400 watts on a nominal 220/250 volt mains supply.

3 ORDERING INFORMATION

| TYPE NUMBER | PACKAGE | | |
|-------------|---------|---|---------|
| | NAME | DESCRIPTION | VERSION |
| OM1654A P | DIP8 | plastic dual in-line package; 8 leads (300 mil) | SOT97-1 |
| OM1654A T | SO8 | plastic small outline package; 8 leads; body width 3.9 mm | SOT96-1 |
| OM1654 P | DIP8 | plastic dual in-line package; 8 leads (300 mil) | SOT97-1 |
| OM1654 T | SO8 | plastic small outline package; 8 leads; body width 3.9 mm | SOT96-1 |

Simple zero-crossing triac control circuit

OM1654A & OM1654

4 PINNING INFORMATION

4.1 Pinning layout (8 pin)

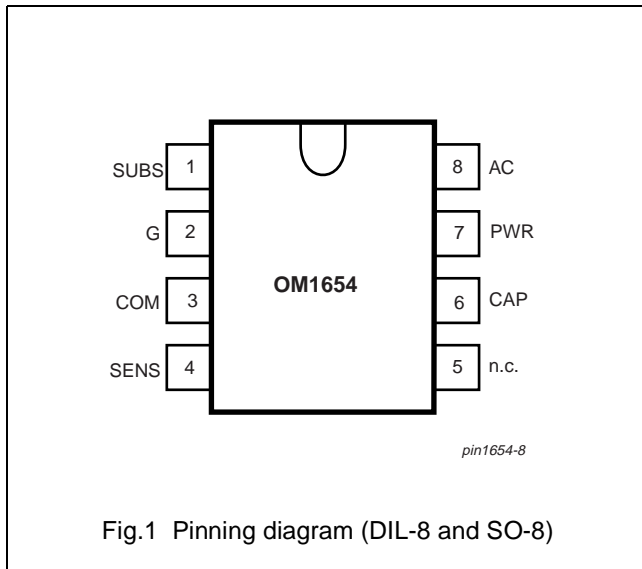

4.2 Pin description (8 pin)

| SYMBOL | PIN | DESCRIPTION |
|-------------|-----|--|
| SUBS | 1 | Negative supply |
| G | 2 | Triac gate drive |
| COM | 3 | Common reference |
| SENS | 4 | Temperature sense |
| n.c. | 5 | not connected |
| CAP | 6 | Timing capacitor |
| PWR or n.c. | 7 | Power supply input (OM1654A), not connected (OM1654) |
| AC | 8 | Mains supply |

5 BLOCK DIAGRAM

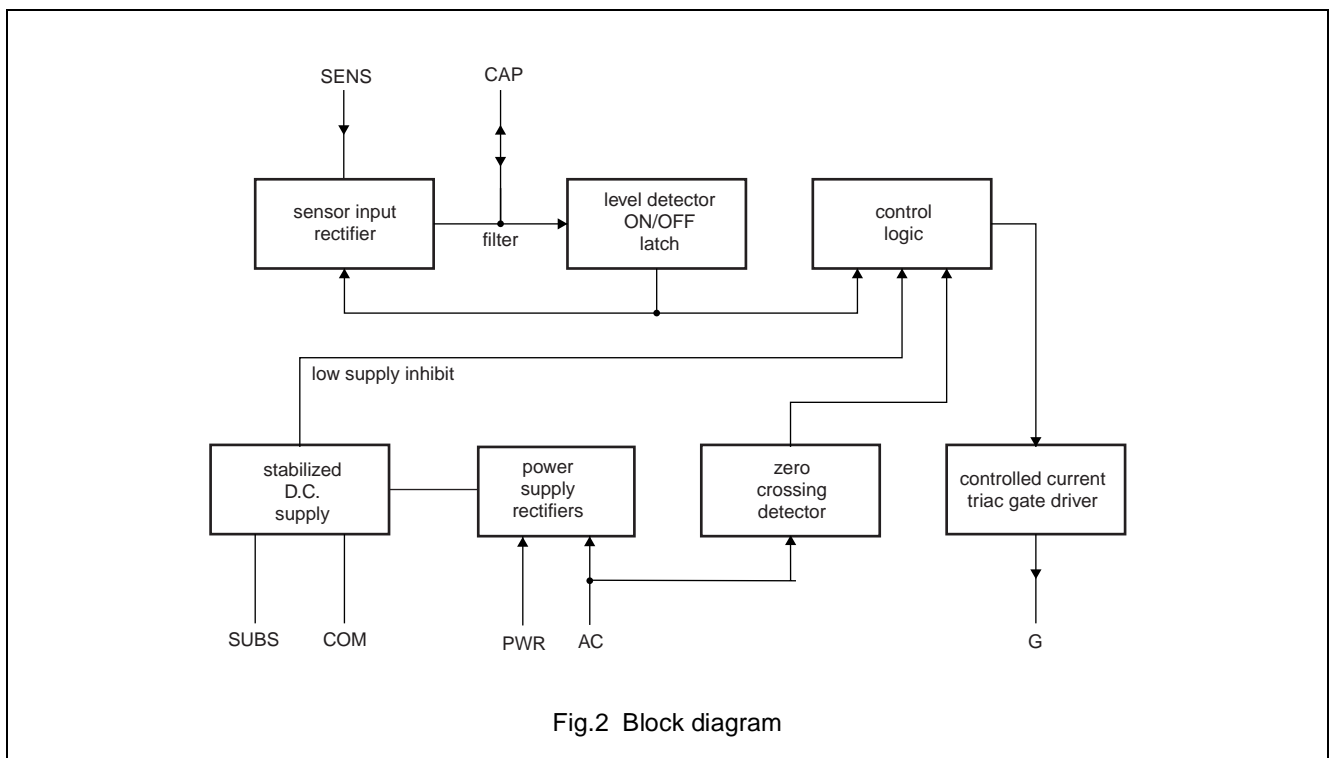

Simple zero-crossing triac control circuit

OM1654A & OM1654

6 FUNCTIONAL DESCRIPTION

6.1 COM – Common, positive DC supply

The positive DC supply rail for the control IC OM1654A and OM1654 is used as the Common reference. This is connected to the TI terminal of the triac, and being the positive supply rail enables negative gate drive to the triac in both positive and negative supply half cycles on T2. By driving the triac in this way the insensitive quadrant (negative T2 voltage, and positive gate triggering signal) is avoided.

6.2 SUBS – Substrate, negative DC supply

The substrate connection is the negative DC power supply terminal of the OM1654. This should be bypassed to COM by a filtering capacitor of 47 microfarads. The operating voltage is approximately –6.8 volts. This capacitor needs to be sufficiently large to maintain the operating voltage during the half cycle when it is not being charged, as well as to provide the energy to drive the triac gate during the gate pulse.

6.3 AC – AC signal, power supply and synchronisation

For the OM1654A the AC input is connected to the active mains supply rail via a resistor chosen to give the required gate pulse width, chosen to ensure that during zero crossing of the mains cycle, the gate signal is applied from before the load current falls below the triac holding current, until after the load current has increased to a value greater than the triac latching current. A resistor from PWR to SUBS may be required to ensure the gate drive pulse is still present when the negative mains voltage is insufficient for the load current to have reached the negative latching current.

In the simplest application (optimised for a 400W load), the AC input is connected via a 220 k Ω resistor to the 220/250 volt AC mains supply line.

The AC input signal is rectified to provide some of the internal supply voltage, and also provides the synchronising information required by the OM1654 to generate the zero crossing signal.

6.4 PWR – Power supply

The OM1654A has an extra pin (PWR) which allows a further resistor to be used to provide an adequate DC power supply while also permitting easy adjustment of the gate pulse width via the AC pin.

The PWR pin is driven by a resistor from the mains Active. This resistor is chosen to ensure that the DC power supply is sufficient to provide the power supply necessary for the function of the OM1654A, and in addition to provide the energy needed for the gate drive. These calculations are described in the OM1654 application note.

6.5 G – Triac gate drive

The triac gate drive output is designed to be connected directly to the gate. It has inbuilt protection to withstand transient signals which may be induced on the gate of the triac by mains transients during firing. The gate drive is designed for a triac with a gate sensitivity which requires less than 10 mA of triggering current, and a suitable latching current. One triac with suitable characteristics is the BT137 series E when used with a load of more than 400 watts.

6.6 CAP – Timing capacitor

The timing capacitor is connected between this pin and the substrate (–ve). The discharge time of this capacitor sets the triac ON time, and is proportional to the capacitance

value (approximately 4 seconds per micro farad). The charging period, or OFF time, varies with the magnitude of the input signal from the sensor. The ON period is synchronised with the mains zero crossing signals so that an integral number of full cycles makes up the ON period, and no nett DC signal is generated in the supply line. The initiation of an ON period is suppressed until the chip power supply reaches its regulated value.

After reaching a valid V_{EE} the chip will stay in operation even if the supply falls to about 4 volts. It won't start until the "zener" first conducts.

6.7 SENS – Sensor input

The sensor input is designed to accept an input which is an AC signal referenced to common; thereby avoiding problems associated with the power dissipation involved in generating sufficient DC current to drive the sensor over its full operating resistance range. If a suitable resistive sensor is used with a parallel level setting potentiometer to apply a proportion of the AC sensor signal to the SENS input, a typical circuit will power this via a 220 k Ω resistor from the AC supply. The SENS input signal threshold is one V_{BE} below the COM rail. Signals with a magnitude greater than this threshold charge the timing capacitor towards the COM rail until it reaches the threshold which initiates an ON cycle. Signals with a magnitude less than this do not charge the capacitor, and the triac drive remains OFF.

External circuits may be used to give greater temperature linearity and accuracy, and improved performance with variation in ambient temperature. The SENS input is only active on negative signals with respect to COM, and therefore either a full AC input may be used, or a signal that is only negatively going with respect to COM.

Simple zero-crossing triac control circuit

OM1654A & OM1654

7 LIMITING VALUES

In accordance with the Absolute Maximum Rating System (IEC 134) Voltages with respect to pin 3(COM)

| SYMBOL | PARAMETER | CONDITIONS | MIN. | MAX. | UNIT |
|---------------------|-------------------------------|------------------|--------------------|------|------|
| V _{supply} | Supply voltage range (SUBS) | V ₁₋₃ | -7.2 | +0.5 | V |
| V _{AC} | Voltage range (AC) | V ₈₋₃ | -7.2 | +0.5 | V |
| V _{PWR} | Voltage range (AC) | V ₈₋₃ | -7.2 | +0.5 | V |
| V _{CAP} | Voltage range (CAP) | V ₆₋₃ | V _{1-0.8} | +0.8 | V |
| V _{SENS} | Voltage range (SENS) | V ₄₋₃ | -1.6 | +0.8 | V |
| V _{Gate} | Voltage range (G) | V ₂₋₃ | V ₁₋₃₀ | +50 | V |
| I | DC current (any pin) | | - | 20 | mA |
| P _{tot} | total power dissipation | | - | 300 | mW |
| T _{stg} | storage temperature | | -40 | +150 | °C |
| T _{amb} | operating ambient temperature | | 0 | +100 | °C |

8 CHARACTERISTICSAt T_{amb} = 25°C; Voltages are specified with respect to V_{COM}, pin 4

| SYMBOL | PARAMETER | CONDITIONS | MIN | TYP | MAX | UNIT |
|--------------------------------|---|-----------------------------------|-----|-------------------------|-----|--------------------|
| Power supply | | | | | | |
| -V _{SUBS} | supply voltage (operating) | | 5.9 | - | 7.6 | V |
| -I _{SUBS} | supply current (operating) | excluding gate drive | - | 80 | 150 | μA |
| Gate drive | | | | | | |
| I _G | gate current (triac T1 to V _{CC}) | V _G = V _{COM} | 10 | 12.5 | - | mA |
| Zero crossing detection | | | | | | |
| I _{AC} | +ve threshold | | - | 45 | - | μA |
| -V _{AC} | -ve threshold | | - | -6.0 | - | V |
| Timing capacitor | | | | | | |
| -I _{CAP} | discharge current | | - | 1 | 2.2 | μA |
| -V _{UT} | upper threshold | | - | 1100 | - | mV |
| -V _{LT} | lower threshold | | - | V _{SUBS} +1100 | 500 | mV |
| I _{CAP} | charge current | I _{SENS} = -20 μA | - | 150 | - | μA |
| Sense input | | | | | | |
| -V _{SENS} | sense voltage | I _{SENS} = -20 μA | - | 1000 | - | mV |
| -V _{SENS} | sense voltage | duty cycle = 50% | - | 575 | - | mV |
| -ΔV _{SENS} /°C | temperature sensitivity | | - | 2.2 | - | mV/°C |
| V _{SENS(rms)} | AC sense voltage | Duty cycle = 5% | - | 0.5 | - | V _(rms) |
| V _{SENS(rms)} | AC sense voltage | Duty cycle = 25% | - | 0.52 | - | V _(rms) |
| V _{SENS(rms)} | AC sense voltage | Duty cycle = 50% | - | 0.54 | - | V _(rms) |
| V _{SENS(rms)} | AC sense voltage | Duty cycle = 75% | - | 0.58 | - | V _(rms) |
| V _{SENS(rms)} | AC sense voltage | Duty cycle = 95% | - | 0.80 | - | V _(rms) |
| V _{SENS(rms)} | AC sense voltage | Duty cycle = 100% | - | 0.92 | - | V _(rms) |

Simple zero-crossing triac control circuit

OM1654A & OM1654

9 APPLICATION INFORMATION

9.1 Design considerations

Figure 3 shows a typical simple circuit for a load of greater than 400W. Either an OM1654A or an OM1654 can be used in this circuit. The PWR pin is not used.

The power supply resistance of 220 k Ω sets the DC power supply current available for the operation of the circuit. When it is required to fire the triac the gate pulse width must be sufficiently long to ensure that the triac load current is greater than the latching current when the gate pulse is removed. Hence the need to specify a minimum operating load for this circuit. At the same time most of the operating DC current derived through the resistor is used in providing the gate signal, thereby putting a tight limit on the upper value of the width of the gate pulse. The width of the gate pulse is derived from the supply voltage and the instantaneous value of the current flowing through the power supply resistor.

In figure 4 an application circuit is shown for a 60W load, using the PWR pin on the OM1654A.

Using a BT134 600E triac for a 60W load on 220V means an 805 Ω load. At 20mA latching current (positive), then the mains voltage for latching is 16V (use 20V) at a phase angle of 3.7 degrees. For 45 μ A in R3 when the mains voltage is 20V, then $R3 = 420\text{k}\Omega$. The supply current at mains peak voltage in R3 is $220 \times 1.414 \times 420 = 0.74\mu\text{A}$ peak.

The negative latching current of the BT134 is -15mA, giving a mains voltage at this time of 15V. Thus when the mains voltage is -15V, from the ration of R3 and R4, the voltage on pin AC must be -6V. Therefore $R4 = 270\text{k}\Omega$, and the firing angle 2.8 degrees.

The gate pulse width is 6.5 degrees, with a duty cycle of 3.6%. That is 722 μ A average for a peak (cold plus margin) gate current of -20mA.

Therefore the average current needed from the power supply is $722 + 150 = 872\mu\text{A}$. Of this $740 \times 0.636 \times 0.5 = 235\mu\text{A}$ is supplied via R3, so R2 must supply 637 μ A average. Therefore R2 is 110k Ω .

A number of important characteristics of the triac are temperature sensitive. It is essential that the controlling integrated circuit exhibits comparable sensitivity to temperature change so that its characteristics vary in the same way as those of the triac, ensuring proper triggering over the full operating range.

9.1.1 NEGATIVE HALF CYCLE

A typical triac has a maximum latching current for the negative half cycle of 25 mA. If the gate pulse is terminated when the supply voltage falls below -6 volts, the minimum load can be calculated for which the holding current is reached before the supply voltage falls to this value. However, with the addition of resistors to SUBS and COM from the AC pin, other threshold voltages can be achieved, allowing other loads.

9.1.2 POSITIVE HALF CYCLE

A typical positive half cycle latching current is 35 mA. Considering chip resistor tolerances, and from the value of the mains power supply resistor of 220 k Ω in figure 3 the end of the gate pulse can be calculated using the threshold current of nominally 45 μ A where the gate drive is turned off.

9.1.3 GATE CURRENT

In assuming a triac gate current of 10 mA minimum an on chip margin has to be allowed for component tolerances, and a suitable variation

with ambient temperature. Also it must be realised that most of the supply current is used in providing the gate current.

Thus in characterising the OM1654 the design has taken into account the availability of suitably sensitive triacs, and used this to employ design figures enabling operation in specific applications with minimum external component count, and yet ensuring reliable triggering and proper operation over normal operating temperature and supply voltage conditions.

9.1.4 TEMPERATURE SENSING

The application circuit in figure 4 is the simplest configuration in which a negative temperature coefficient (NTC) thermistor or another resistive sensing element can be used. Note that at the low temperature end of the potentiometer travel no sensing signal is available at all. However simple resistor networks are usually needed to linearise the response of the setting resistor against control temperature, and can easily be designed to allow for maximum and minimum operating points. Alternatively these might be set mechanically by stops inherent in the mechanical construction of the product using the OM1654.

Some applications require more accurate control over a limited temperature range; for example the control of fish tank heaters or water bed thermostats. Use of an input bridge circuit with gain will permit greater accuracy, and exhibit less ambient temperature dependence (for example by using one external transistor). These circuits still use an AC sensing circuit, and therefore do not provide any additional loading on the DC power supply.

Simple zero-crossing triac control circuit

OM1654A & OM1654

9.2 Application circuits

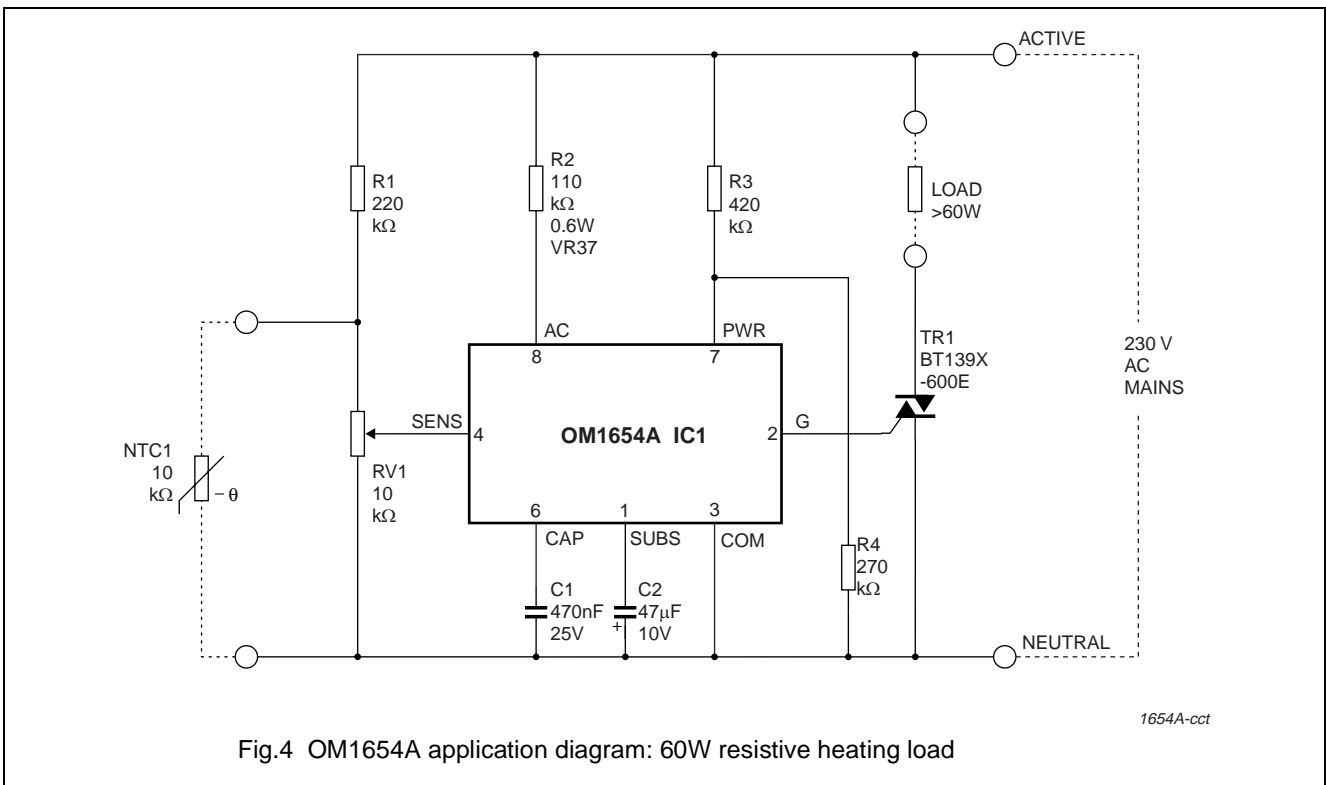
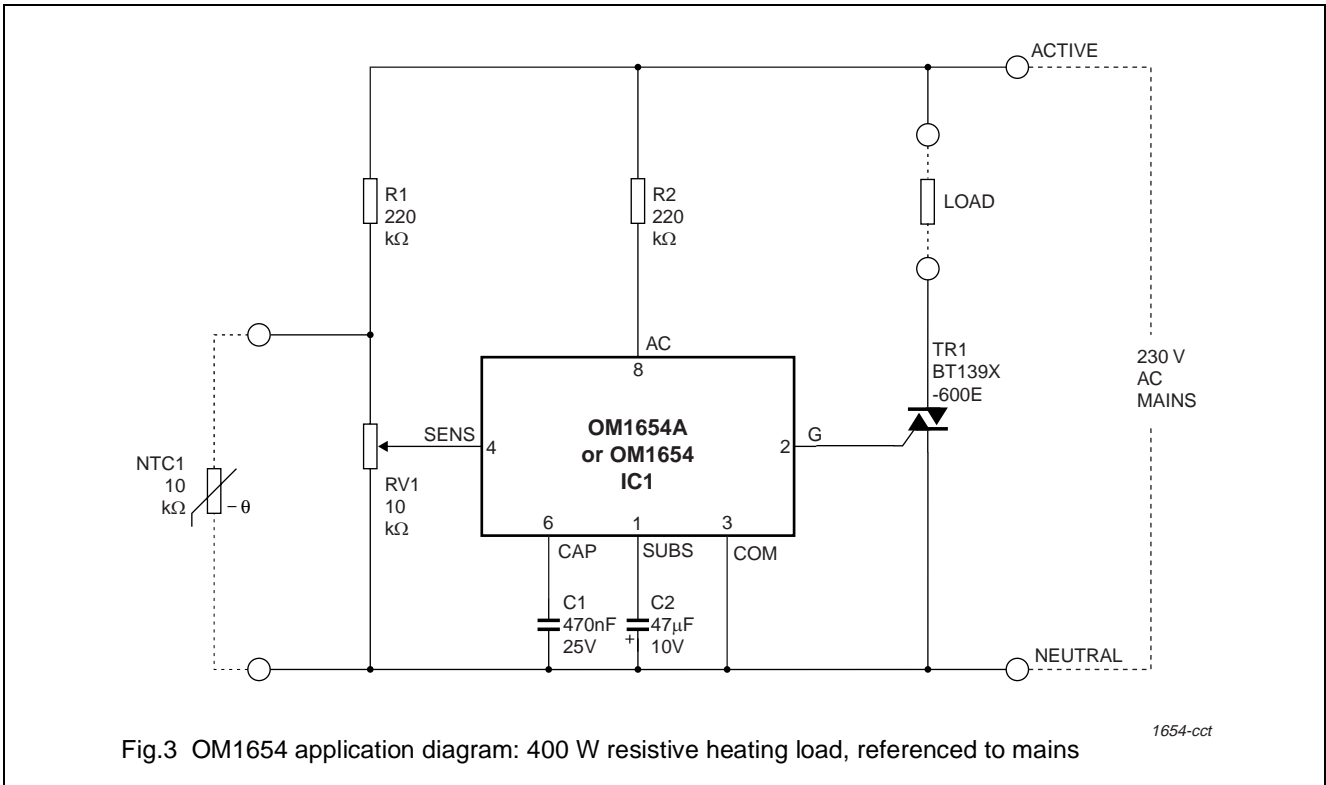

Simple zero-crossing triac control circuit

OM1654A & OM1654

10 PACKAGE OUTLINES

DIP8: plastic dual in-line package; 8 leads (300 mil)

SOT97-1

0 5 10 mm
scale

DIMENSIONS (inch dimensions are derived from the original mm dimensions)

| UNIT | A max. | A ₁ min. | A ₂ max. | b | b ₁ | b ₂ | c | D ⁽¹⁾ | E ⁽¹⁾ | e | e ₁ | L | M _E | M _H | w | Z ⁽¹⁾ max. |
|--------|--------|---------------------|---------------------|----------------|----------------|----------------|----------------|------------------|------------------|------|----------------|--------------|----------------|----------------|-------|-----------------------|
| mm | 4.2 | 0.51 | 3.2 | 1.73 1.14 | 0.53 0.38 | 1.07 0.89 | 0.36 0.23 | 9.8 9.2 | 6.48 6.20 | 2.54 | 7.62 | 3.60 3.05 | 8.25 7.80 | 10.0 8.3 | 0.254 | 1.15 |
| inches | 0.17 | 0.020 | 0.13 | 0.068 0.045 | 0.021 0.015 | 0.042 0.035 | 0.014 0.009 | 0.39 0.36 | 0.26 0.24 | 0.10 | 0.30 | 0.14 0.12 | 0.32 0.31 | 0.39 0.33 | 0.01 | 0.045 |

Note
1. Plastic or metal protrusions of 0.25 mm maximum per side are not included.

| OUTLINE VERSION | REFERENCES | | | EUROPEAN PROJECTION | ISSUE DATE |
|-----------------|------------|----------|------|---------------------|----------------------|
| | IEC | JEDEC | EIAJ | | |
| SOT97-1 | 050G01 | MO-001AN | | | 92-11-17 95-02-04 |

Simple zero-crossing triac control circuit

OM1654A & OM1654

SO8: plastic small outline package; 8 leads; body width 3.9 mm

SOT96-1

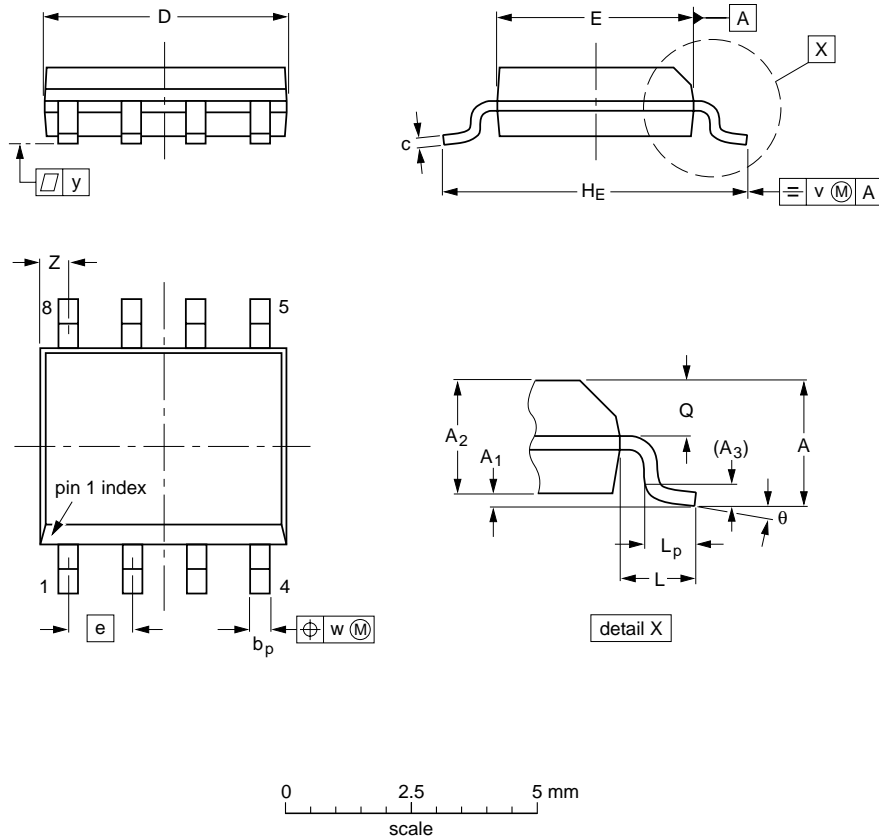

DIMENSIONS (inch dimensions are derived from the original mm dimensions)

| UNIT | A max. | A ₁ | A ₂ | A ₃ | b _p | c | D ⁽¹⁾ | E ⁽²⁾ | e | H _E | L | L _p | Q | v | w | y | z ⁽¹⁾ | θ |
|--------|--------|----------------|----------------|----------------|----------------|------------------|------------------|------------------|-------|----------------|-------|----------------|----------------|------|------|-------|------------------|----------|
| mm | 1.75 | 0.25 0.10 | 1.45 1.25 | 0.25 | 0.49 0.36 | 0.25 0.19 | 5.0 4.8 | 4.0 3.8 | 1.27 | 6.2 5.8 | 1.05 | 1.0 0.4 | 0.7 0.6 | 0.25 | 0.25 | 0.1 | 0.7 0.3 | 8° 0° |
| inches | 0.069 | 0.010 0.004 | 0.057 0.049 | 0.01 | 0.019 0.014 | 0.0100 0.0075 | 0.20 0.19 | 0.16 0.15 | 0.050 | 0.244 0.228 | 0.041 | 0.039 0.016 | 0.028 0.024 | 0.01 | 0.01 | 0.004 | 0.028 0.012 | |

Notes

1. Plastic or metal protrusions of 0.15 mm maximum per side are not included.
2. Plastic or metal protrusions of 0.25 mm maximum per side are not included.

| OUTLINE VERSION | REFERENCES | | | EUROPEAN PROJECTION | ISSUE DATE |
|-----------------|------------|----------|------|---------------------|----------------------|
| | IEC | JEDEC | EIAJ | | |
| SOT96-1 | 076E03S | MS-012AA | | | 95-02-04 97-05-22 |

Simple zero-crossing triac control circuit

OM1654A & OM1654

11 SOLDERING

11.1 Introduction

There is no soldering method that is ideal for all IC packages. Wave soldering is often preferred when through-hole and surface mounted components are mixed on one printed-circuit board. However, wave soldering is not always suitable for surface mounted ICs, or for printed-circuits with high population densities. In these situations reflow soldering is often used.

This text gives a very brief insight to a complex technology. A more in-depth account of soldering ICs can be found in the Philips "*IC Package Data book*" (code 9398 652 90011).

11.2 DIP

11.2.1 SOLDERING BY DIPPING OR BY WAVE

The maximum permissible temperature of the solder is 260 °C; solder at this temperature must not be in contact with the joint for more than 5 seconds. The total contact time of successive solder waves must not exceed 5 seconds.

The device may be mounted up to the seating plane, but the temperature of the plastic body must not exceed the specified maximum storage temperature ($T_{stg\ max}$). If the printed-circuit board has been pre-heated, forced cooling may be necessary immediately after soldering to keep the temperature within the permissible limit.

11.2.2 REPAIRING SOLDERED JOINTS

Apply a low voltage soldering iron (less than 24 V) to the lead(s) of the package, below the seating plane or not more than 2 mm above it. If the temperature of the soldering iron bit is less than 300 °C it may remain in contact for up to 10 seconds. If the bit temperature is between

300 and 400 °C, contact may be up to 5 seconds.

11.3 SO

11.3.1 REFLOW SOLDERING

Reflow soldering techniques are suitable for all SO packages.

Reflow soldering requires solder paste (a suspension of fine solder particles, flux and binding agent) to be applied to the printed-circuit board by screen printing, stencilling or pressure-syringe dispensing before package placement.

Several techniques exist for reflowing; for example, thermal conduction by heated belt. Dwell times vary between 50 and 300 seconds depending on heating method. Typical reflow temperatures range from 215 to 250 °C.

Preheating is necessary to dry the paste and evaporate the binding agent. Preheating duration: 45 minutes at 45 °C.

11.3.2 WAVE SOLDERING

Wave soldering techniques can be used for all SO packages if the following conditions are observed:

- A double-wave (a turbulent wave with high upward pressure followed by a smooth laminar wave) soldering technique should be used.
- The longitudinal axis of the package footprint must be parallel to the solder flow.
- The package footprint must incorporate solder thieves at the downstream end.

During placement and before soldering, the package must be fixed with a droplet of adhesive. The adhesive can be applied by screen printing, pin transfer or syringe

dispensing. The package can be soldered after the adhesive is cured.

Maximum permissible solder temperature is 260 °C, and maximum duration of package immersion in solder is 10 seconds, if cooled to less than 150 °C within 6 seconds. Typical dwell time is 4 seconds at 250 °C.

A mildly-activated flux will eliminate the need for removal of corrosive residues in most applications.

11.3.3 REPAIRING SOLDERED JOINTS

Fix the component by first soldering two diagonally- opposite end leads. Use only a low voltage soldering iron (less than 24 V) applied to the flat part of the lead. Contact time must be limited to 10 seconds at up to 300 °C. When using a dedicated tool, all other leads can be soldered in one operation within 2 to 5 seconds between 270 and 320 °C.

Simple zero-crossing triac control circuit

OM1654A & OM1654

Notes:

Simple zero-crossing triac control circuit

OM1654A & OM1654

Notes:

Simple zero-crossing triac control circuit

OM1654A & OM1654

Notes:

Simple zero-crossing triac control circuit

OM1654A & OM1654

12 DEFINITIONS

| Data sheet status | |
|---|---|
| Engineering sample information | This contains draft information describing an engineering sample provided to demonstrate possible function and feasibility. Engineering samples have no guarantee that they will perform as described in all details. |
| Objective specification | This data sheet contains target or goal specifications for product development. Engineering samples have no guarantee that they will function as described in all details. |
| Preliminary specification | This data sheet contains preliminary data; supplementary data may be published later. Products to this data may not yet have been fully tested, and their performance fully documented. |
| Product specification | This data sheet contains final product specifications. |
| Limiting values | |
| Limiting values given are in accordance with the Absolute Maximum Rating System (IEC 134). Stress above one or more of the limiting values may cause permanent damage to the device. These are stress ratings only and operation of the device at these or at any other conditions above those given in the Characteristics sections of the specification is not implied. Exposure to limiting values for extended periods may affect device reliability. | |
| Application information | |
| Where application information is given, it is advisory and does not form part of the specification. | |

13 IES INFORMATION

INTEGRATED ELECTRONIC SOLUTIONS PTY. LTD.
 ABN 17 080 879 616

Postal address:

Integrated Electronic Solutions
 PO Box 2226
 Port Adelaide SA 5015
 AUSTRALIA

Street Address:

Integrated Electronic Solutions
 1 Butler Drive
 Hendon SA 5014
 AUSTRALIA

Telephone: +61 8 8348 5200
 Facsimile: +61 8 8243 1048

World Wide Web: www.ies-sa.com

Email: IES@ies.sa.com.au

Simple zero-crossing triac control circuit

OM1654A & OM1654

14 DISCLAIMER

Integrated Electronic Solutions Pty. Ltd. ABN 17 080 879 616 ("IES") reserves the right to make changes to both its products and product data without notice.

IES makes no warranty, representation or guarantee regarding the suitability of its products for any particular purpose, nor does IES assume any liability arising out of the use or application of any IES product. IES specifically disclaims any and all liability, including without limitation incidental or consequential damages.

Typical performance figures, where quoted may depend on the application and therefore must be validated by the customer in each particular application. It is the responsibility of customers to ensure that any designs using IES products comply with good practice, applicable standards and approvals. IES accepts no responsibility for incorrect or non-compliant use of its products, failure to meet appropriate standards and approvals in the application of IES products, or for the correct engineering choice of other connected components, layout and operation of IES products.

Any customer purchasing or using IES product(s) for an unintended or unauthorised application shall indemnify and hold IES and its officers, employees, related companies, affiliates and distributors harmless against all claims, costs, damages, expenses, and reasonable legal fees arising out of, directly or indirectly, any claim of loss, personal injury or death associated with such unintended or unauthorised use, even if such claim alleges that IES was negligent regarding the design or manufacture of the relevant product(s).

Life Support Applications

Products of Integrated Electronic Solutions Pty Ltd (IES) are not designed for use in life support appliances, devices or systems, where malfunction can result in personal injury. Customers using or selling IES products for use in such applications do so at their own risk and agree to fully indemnify IES for any damages resulting from such improper use or sale.