

# FAN4810EVAL

## Evaluation Kit User's Guide

### Power Factor Controller

#### General Description

The FAN4810 Evaluation Board is a power-factor-corrected 500W off-line power supply. The supply has a single 400V output and operates over an input voltage range of 90 VAC to 265 VAC. The Evaluation Board uses an average mode boost PFC that allows it to be fully complaint with IEC 61000-3-2 limits for harmonic emission.

When operating the FAN4810 Evaluation Board there are two things to keep in mind. A minimum load of 15 to 20 Watts is required to prevent output from rising to the OVP point. This will provide continuous operation and prevent the PFC from periodic shutdown due to OVP. Also, there is no current inrush limiting included in the Evaluation Board. Because of this it is suggested that the input voltage is always ramped up slowly.

#### Evaluation Kit Contents

The FAN4810 Evaluation Kit contains the following items:

1. FAN4810 Evaluation Kit Users Guide
2. Fully Functional FAN4810 Evaluation Board

#### Circuit Design

Refer to Application Note, AN-6004 for detailed design information on this board.

##### **CAUTION!**

The FAN4810 Evaluation Board contains voltage potentials capable of causing serious injury, and components that may shatter or explode if they fail. Appropriate precautions must be taken to prevent injury should such situations occur. The use of protective eyewear is strongly recommended.

To safely observe circuit waveforms, an isolation transformer should be used between the Evaluation Board and the AC line.

**Do not operate this board with DC/AC voltages outside the design limits.**

Replace circuit components only with those recommended in the parts list of this User's Guide.

#### How to Operate

Use the following procedure to safely operate the power supply.

1. Connect a 100W load across the output terminals (J3 and J4).
2. Connect a DC voltmeter across the output terminals.
3. Connect an isolated variable AC source (such as a variac) to input terminals J1 and J2. A DC source may be substituted at the input for easier examination of the waveforms.
4. Slowly increase the AC input voltage to at least 90VAC (Do not exceed 265VAC). If applying a DC input increase it to 120 Volts.
5. Confirm that the output voltage increases as the input voltage is increased.
6. As the input voltage approaches very close to 90VAC (120VDC) the Board output should read approximately 404VDC within 5 sec.
7. Remove the AC input and verify that the output voltage has dropped to zero.
8. Connect a 500W load across the output terminals and reapply the AC input.

#### Performance Data

To measure the Eval Board performance across the range of permissible input voltages use an isolated Variac or adjustable AC source. It is suggested that the input voltage is increased slowly as the evaluation board has no inrush current limiting.

A typical FAN4810 evaluation board will have the performance characteristics shown in Figure 1 when operated as specified in the Test Conditions.

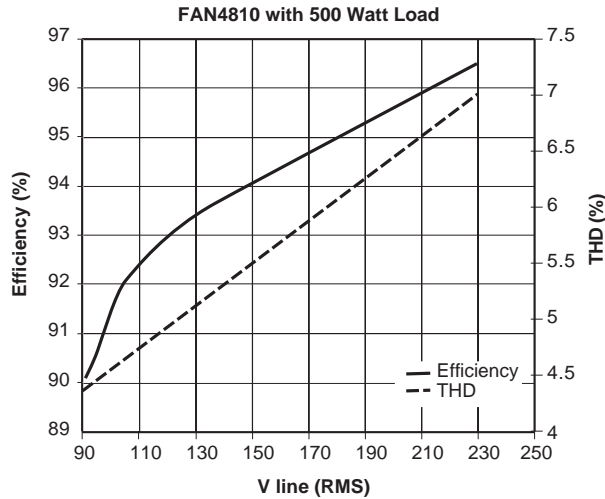

Figure 1. FAN4810 Evaluation Board Test Results

Test Conditions: 500 Watt load on output at 25°C

Equipment Used: Voltech Digital Single-Phase Power Analyzer Model PM100, 500W Electronic load.

Power Ratings

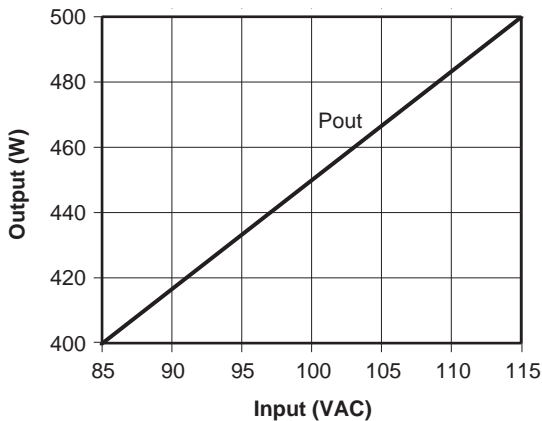

Figure 2. Output Power vs. Line Voltage

The FAN4810 Evaluation Board is designed to provide up to 500W output with an input of 90VAC. Due to thermal limitations the actual output with no fan is limited to  $\leq 400W$  at inputs below 115VAC, and up to 40°C ambient. Figure 2 displays the maximum power vs. line voltage with no fan. Above 115VAC input the maximum output power is 500W.

The unit will safely provide 500W at 90 VAC input with adequate fan cooling. Note that even though the FAN4810 Evaluation board can achieve 500 Watts with additional fan cooling, the heatsinks utilized are not optimal for use with a fan.

Layout Considerations

The FAN4810 Evaluation board contains high impedance, low-level signals and low impedance, high level circuits; consequently extra care is required in component placement, grounding and PC trace routing. In order to shield low-level circuits from the high level signals, control circuits were placed in surface mount form on the bottom side of the board. This allowed a return shield to be placed on the top-side. Since the current sense for the FAN4810 is not differential, care must be taken to prevent a large di/dt from occurring across the PCB trace joining the output cap (assumed to be the reference return for the IC) to the current sense resistor. Since the best reference for the IC is at the output cap return potential (the most stable potential), the difference between this potential and the current sense resistor return potential must be kept to a minimum. This is done by star-grounding all the 400V return connections to the output capacitor, and/or maintaining very low inductive/resistive paths from all power devices to the output capacitor return.

Some general layout guidelines:

- A. Return the low side of the timing capacitor (C18) directly to the IC ground pin.
- B. Bypass the reference and supply voltage pins directly to the IC ground pin with a 1  $\mu F$ , low ESR/ESL capacitor.
- C. Return all compensation components directly to the IC ground pin, keeping the lead lengths as short as possible.
- D. Make sure that low-level, noise free, returns do not share return paths with high-level, or noisy, signals (e.g., gate drive).
- E. Isolate and/or shield rapidly changing waveforms, such as the drain of Q1 from sensitive, high impedance circuits, such as the timing capacitor, PFC current sense input, error amplifier input/output, etc.

## FAN4810 Evaluation Board Parts List

Qty	Description	Vendor/Parts/Distributor	Designation
<b>Resistors</b>			
2	453k $\Omega$ , 1/8 W, 1%, SMD 1206	Any	R1A, R1B
2	453k $\Omega$ , 1/8 W, 1%, SMD 1206	Any	R2A, R2B
1	100k $\Omega$ , 1/8 W, 1%, SMD 1206	Any	R3
1	15.8k $\Omega$ , 1/8 W, 1%, SMD 1206	Any	R4
1	0.050 $\Omega$ , 3W, 1%	Ohmite, 15FR050	R5
1	41.2k $\Omega$ , 1/8 W, 1 %, SMD 1206	Any	R6
1	127k $\Omega$ , 1/4 W, 1%, SMD 1210	Any	R7A, R7B, R7C
1	2.37k $\Omega$ , 1/8 W, 1%, SMD 1206	Any	R8
1	10k $\Omega$ , 1/8 W, 5%, SMD 1206	Any	R9
1	47 $\Omega$ , 1/4 W, 5%, SMD 1210	Any	R10
1	511k $\Omega$ , 1/8 W, 5%, SMD 1206	Any	R11
1	33.2k $\Omega$ , 1/8 W, 1%, SMD 1206	Any	R12
2	39k $\Omega$ , 2W, 5%, metal film	Any	R14, R13
1	0 $\Omega$ , Jumper, 1206	Any	R15
1	200k $\Omega$ , 1/8 W, 5%, SMD 1206	Any	R16
1	100 $\Omega$ , 1/8 W, 5%, 1206	Any	R17
1	10 $\Omega$ , 1/8 W, 5%, 1206	Any	R18
1	22 $\Omega$ , 1/8 W, 5%, 1206	Any	R19
<b>Capacitors</b>			
1	0.47 $\mu$ F, 250 VAC, 20% Metallized Polyester	Wima MKS4-R	C1
1	0.47 $\mu$ F, 16V, 10% X7R Ceramic 1206	Murata / GRM42-6X7R474K016AB	C2
3	0.1 $\mu$ F, 50V, 10%, X7R Ceramic 1206	Murata / GRM42-6X7R104K050AB	C3, C8, C19
1	0.047 $\mu$ F 630VDC, 10%, polypropylene	WIMA, MKP10	C4
1	330 $\mu$ F, 450V, 20%, Electrolytic	Panasonic TSU-Series	C5
1	2.2nF, 50V, 10%, X7R Ceramic 1206	Any	C6
1	47pF, 25V, 10%, Ceramic	Any	C7
1	0.01 $\mu$ F, 50V, 10%, X7R Ceramic 1206	Any	C9
8	1 $\mu$ F, 50V, 10%, X7R Ceramic 1210	Any	C10, C11, C12, C13, C14, C16, C20, C21
1	1500 $\mu$ F, 25V, Electrolytic	Panasonic / ECA-1EFQ152L	C15
1	1000pF, 50V, 20%, X7R Ceramic 1206	Any	C17
1	470pF, 25V, 5%, C0G Ceramic 1206	Any	C18
<b>Diodes</b>			
1	600V, 15A Stealth Diode	Fairchild ISL9R1560P2	D1
1	600V, 3A Rectifier Diode	Fairchild 1N5406	D2
2	50V, 1A Fast Recovery Diode	Fairchild RGF1A	D3, D4
1	20V 1W Zener Diode	Fairchild 1N4747A	D5
2	100V, 3A Rectifier Diode	Fairchild 1N5401	D6, D7
1	20V, 500mA Schottky Rectifier	Fairchild MBR0520L	D8
1	600V, 25A Bridge Rectifier	Fairchild GBPC2506	B1

**FAN4810 Evaluation Board Parts List** (continued)

Qty	Description	Vendor/Parts/Distributor	Designation
<b>Transistors</b>			
1	500V, 24A MOSFET	Fairchild FQA24N50	Q1
1	MMBT3904, 200mA, 40V, NPN Transistor	Fairchild	Q2
2	MMBT3906, 200mA, 40V, PNP Transistor	Fairchild	Q3, Q4
<b>ICs</b>			
1	FAN4810IM Power Factor Cont.	Fairchild Semiconductor	U1
<b>Magnetics</b>			
1	420 $\mu$ H, 10A	Premier Magnetics Inc. / TSD-902 Pulse / P0316	L1
<b>Fuse</b>			
1	8 Amp 250 VAC Fast Acting	Little Fuse / Series 217	F1
<b>Hardware</b>			
2	5x20 Fuse Clips	Little Fuse	
1	TO220 Heatsinks	Aavid / 534265BO3453	(Ref. D1)
1	TO220/TO218 Heatsink	Thermalloy / 6300B	(Ref. Q1)
1	TO220 Insulator, Sarcon Tube	Fujipoly / 30T-11-1000L	(Ref. D1)
1	TO218 Insulator	Fujipoly / 30T-TO-3PF Bergquist / K10-104	(Ref. Q1)
4	Standard Banana Plug	Johnson Comp. / 108-0740-001	J1, J2, J3, J4
1	6-32 1/2" Phillips Machine Screw		(Ref. Q1)
2	6-32 Lock Washer		(Ref. Q1)
2	6-32 Hex Nut		(Ref. Q1)
5	4-40 5/16" Phillips Machine Screw		
5	4-40 Lock Washer		
5	4-40 0.875" Hex threaded spacers	Johnson Components Digi-Key / J176-ND	
1	Unthreaded round aluminum or nylon Spacer, 1/4" OD, 0.140" ID, 1/4" Length	Johnson Components Digi-Key / J169-ND	
1	Blank Evaluation Board		
8	Thru-Hole Test Pins, 3M Series 2400	Digi-Key / 929834-02-36-ND	TP1, TP2, TP3, TP4, TP5, TP6, TP7, TP8

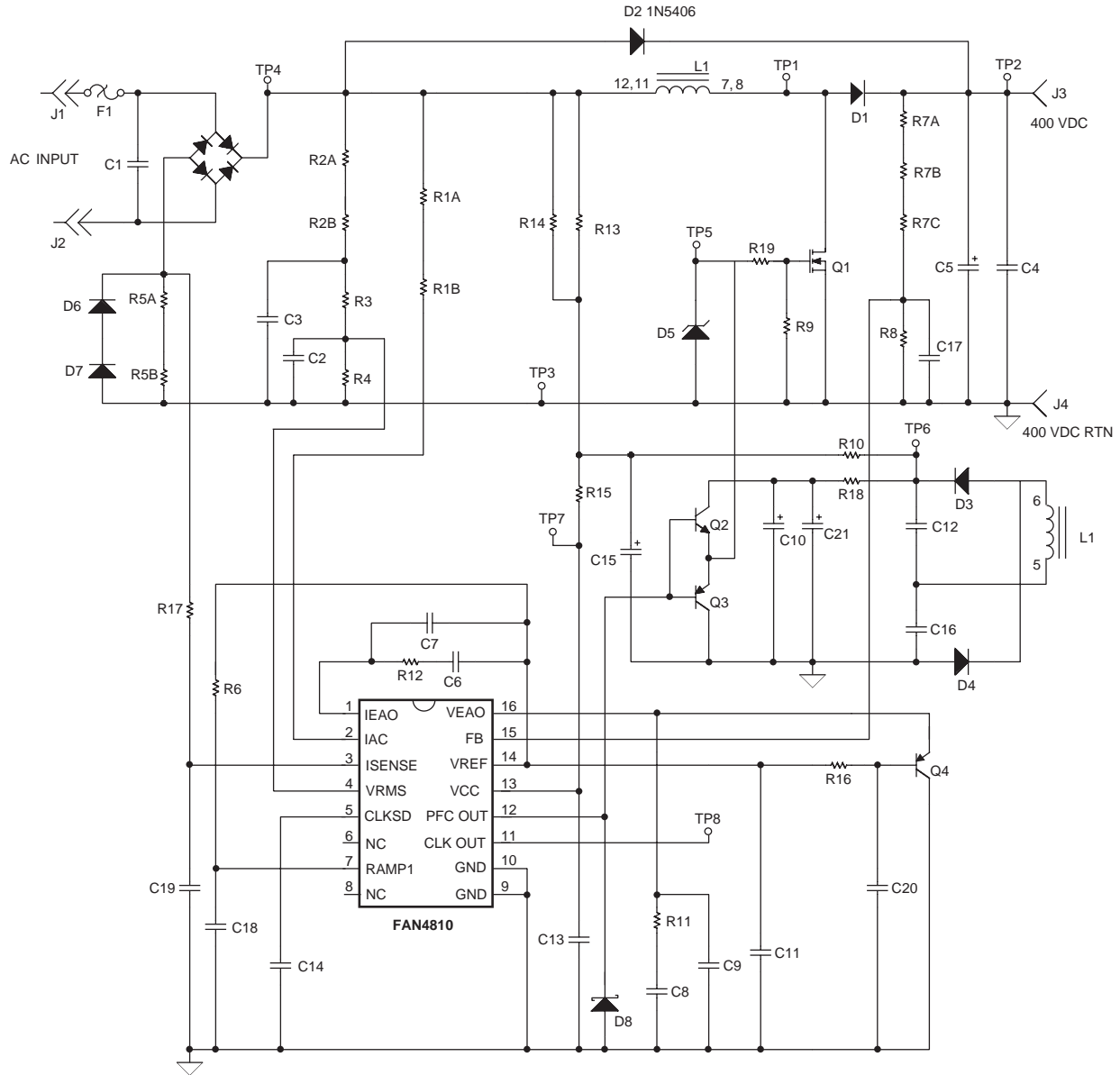

Figure 3. Schematic

**DISCLAIMER**

FAIRCHILD SEMICONDUCTOR RESERVES THE RIGHT TO MAKE CHANGES WITHOUT FURTHER NOTICE TO ANY PRODUCTS HEREIN TO IMPROVE RELIABILITY, FUNCTION OR DESIGN. FAIRCHILD DOES NOT ASSUME ANY LIABILITY ARISING OUT OF THE APPLICATION OR USE OF ANY PRODUCT OR CIRCUIT DESCRIBED HEREIN; NEITHER DOES IT CONVEY ANY LICENSE UNDER ITS PATENT RIGHTS, NOR THE RIGHTS OF OTHERS.

**LIFE SUPPORT POLICY**

FAIRCHILD'S PRODUCTS ARE NOT AUTHORIZED FOR USE AS CRITICAL COMPONENTS IN LIFE SUPPORT DEVICES OR SYSTEMS WITHOUT THE EXPRESS WRITTEN APPROVAL OF THE PRESIDENT OF FAIRCHILD SEMICONDUCTOR CORPORATION. As used herein:

1. Life support devices or systems are devices or systems which, (a) are intended for surgical implant into the body, or (b) support or sustain life, and (c) whose failure to perform when properly used in accordance with instructions for use provided in the labeling, can be reasonably expected to result in a significant injury of the user.
2. A critical component in any component of a life support device or system whose failure to perform can be reasonably expected to cause the failure of the life support device or system, or to affect its safety or effectiveness.