



TRINAMIC® Microchips GmbH
Deelbögenkamp 4C
D – 22297 Hamburg
GERMANY

T +49 - (0) 40 - 51 48 06 - 0
F +49 - (0) 40 - 51 48 06 - 60
WWW.TRINAMIC.COM
INFO@TRINAMIC.COM

TMC 239 – DATA SHEET

High Current Microstep Stepper Motor Driver with protection / diagnosis and SPI Interface



Features

The TMC239 is a dual full bridge driver IC for stepper motor control applications. It is realized in a HVCMOS technology and directly drives eight external Low-RDS-ON high efficiency MOSFETs. The driver transistors can be chosen depending on output current or environment temperature. Its low current consumption and high efficiency together with the miniature package make the TMC239 a perfect solution for embedded motion control and for battery powered devices. It supports more than 3000mA coil current. With additional drivers, motor current and voltage can be increased. Internal DACs allow microstepping as well as smart current control. The device can be controlled by a serial interface (SPI™) or by analog / digital input signals. Short circuit, temperature and undervoltage protection is integrated.

- Control via SPI with easy-to-use 12 bit protocol or external analog / digital signals
- Short circuit and over temperature protection integrated
- Status flags for overcurrent, open load, over temperature, temperature pre-warning, undervoltage
- Integrated 4 bit DACs allow up to 16 times microstepping via SPI, any resolution via analog control
- Mixed decay feature for smooth motor operation
- Slope control user programmable to reduce electromagnetic emissions
- Chopper frequency programmable via a single capacitor or external clock
- Current control allows cool motor and driver operation
- Internal open load detector
- 7V to 30V motor supply voltage
- More than 3000mA using 8 external MOS transistors
- External drivers can be added for higher motor voltages and higher currents (e.g. 75V, 10A)
- Only 4 external PMOS transistors required for unipolar operation
- 3.3V or 5V operation for digital part
- Low power consumption via low RDS-ON power stage
- Standby and shutdown mode available

Life support policy

TRINAMIC Microchips GmbH does not authorize or warrant any of its products for use in life support systems, without the specific written consent of TRINAMIC Microchips GmbH.

Life support systems are equipment intended to support or sustain life, and whose failure to perform, when properly used in accordance with instructions provided, can be reasonably expected to result in personal injury or death.

© TRINAMIC Microchips GmbH 2002

Information given in this data sheet is believed to be accurate and reliable. However no responsibility is assumed for the consequences of its use nor for any infringement of patents or other rights of third parties, which may result from its use.

Specifications subject to change without notice.

Pinning

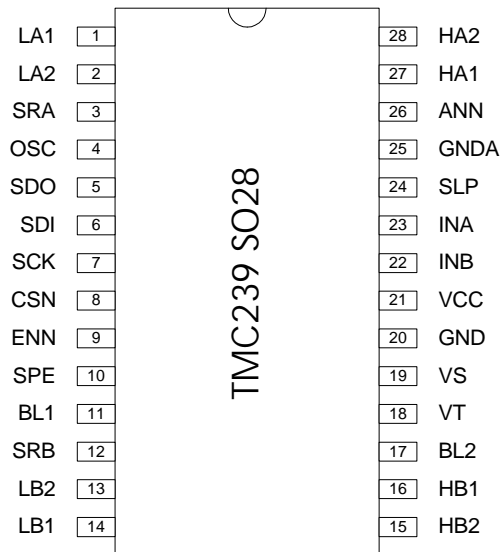

Package codes

Package	Temperature range	Code/markings
SO28	automotive *)	TMC239-SA
LPCC28 (6*6mm) to be announced	automotive	TMC239-LA

*) ICs with date code prior to 0104 are not yet tested according to automotive standards, but are usable within the complete temperature range.

SO28 Dimensions

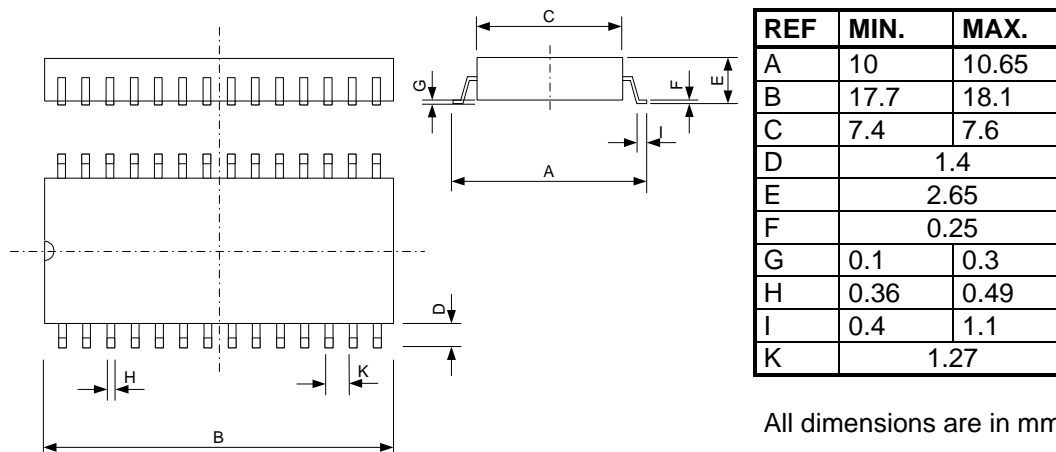

Application Circuit / Block diagram

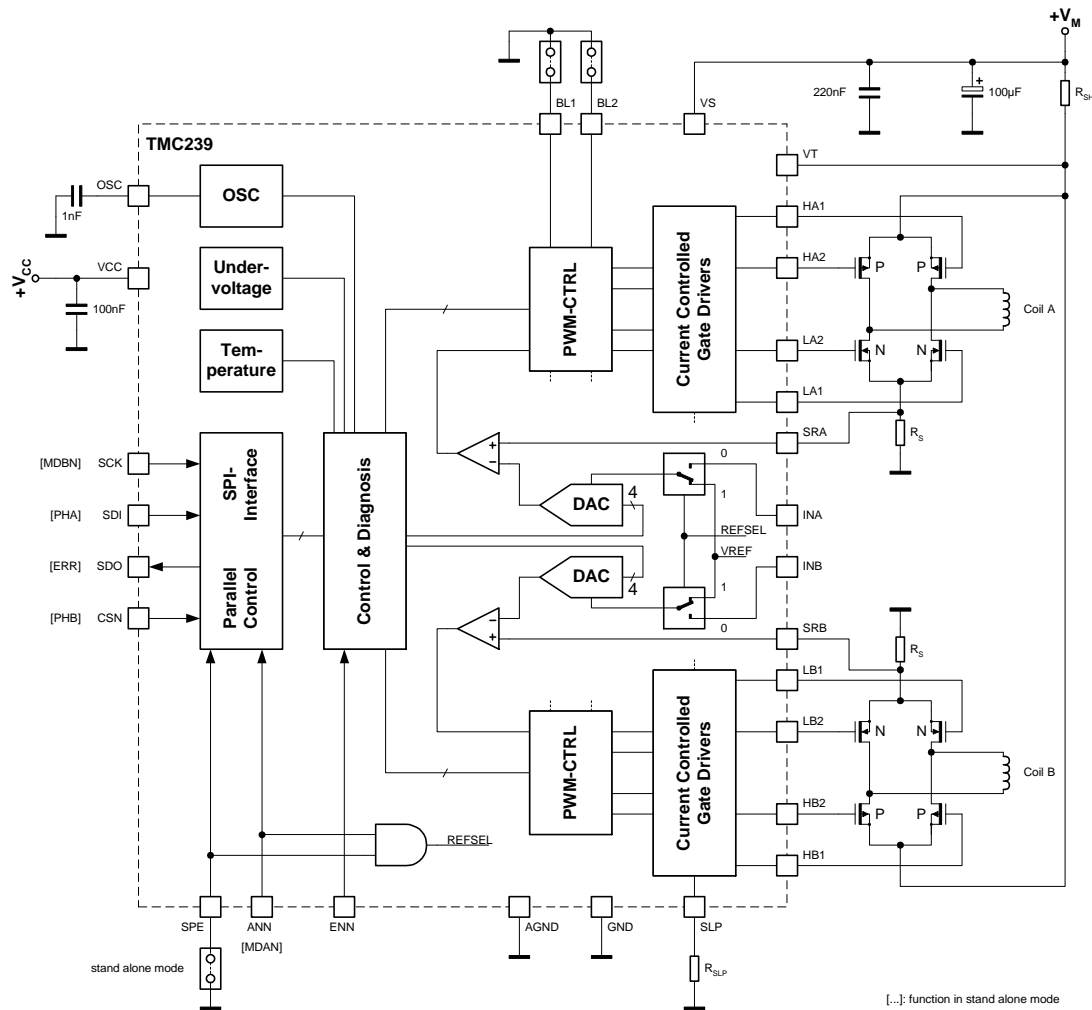

Pin functions

Pin	Function	Pin	Function
VS	Motor supply voltage	VT	Short to GND detection comparator – connect to VS if not used
VCC	3.0-5.5V supply voltage for analog and logic circuits	GND	Power ground
AGND	Analog ground (Reference for SRA, SRB, OSC, SLP, INA, INB)	OSC	Oscillator capacitor or external clock input for chopper
INA	Analog current control phase A	INB	Analog current control input phase B
SCK	Clock input of serial interface	SDI	Data input of serial interface
SDO	Data output of serial interface	CSN	Chip select input of serial interface
ENN	Device enable (low active), high causes a total shutdown and resets all registers	SPE	Enable SPI mode (high active). Tie to GND for non-SPI applications
ANN	Enable analog current control (low active): Enables INA and INB for output current control	SLP	Slope control resistor. Tie to GND for fastest slope
BL1, BL2	Digital blank time select	SRA, SRB	Bridge A/B current sense resistor input
HA1, HA2, HB1, HB2	Outputs for high side P-channel transistors	LA1, LA2, LB1, LB2	Outputs for low side N-channel transistors

Selecting power transistors

Selection of power transistors for the TMC239 depends on required current, voltage and thermal conditions. Driving transistors directly with the TMC239 is only limited by the gate capacity of these transistors. If the total gate charge is too high, slope time increases and leads to a higher switching power dissipation. Typical applications can reach a current in excess of 3A, while the maximum voltage is limited to 30V. A total gate charge of below 10nC per transistor is recommended. The table below shows a choice of transistors which can be driven directly by the TMC239. The maximum application current mainly is a function of cooling and environment temperature. The given values are more conservative. Peak currents typically can be higher by a factor of 1.5 for a limited time.

List of recommended transistors

Manufacturer and type	Package (#Trans)	Volts N-type Volts P-type	RDS _{ON} [Ohm]	Total gate charge [nC]	Typical maximum application current
Siliconix SI 3552	TSOP6 (1N,1P)	30V 30V	0.105 0.200	2.5 3.0	1500mA
Siliconix SI 5504	1206-8 (1N,1P)	30V 30V	0.085 0.165	5.0 5.5	2000mA
ST Micro STS2DNF30L STS3DPF30L	SO8 (2N) (2P)	30V 30V	0.11 0.15	4.5 5.5	2000mA
IRF 5851	TSOP6 (1N,1P)	20V 20V	0.090 0.135	6.0 6.0	1500mA
IRF 9952	SO8 (1N,1P)	30V 30V	0.10 0.25	6.9 6.1	2500mA
IRF 7509	Micro8 (1N,1P)	30V 30V	0.11 0.20	7.8 7.5	2000mA
Fairchild Semi FDS 8333C	SO8 (1N,1P)	30V 30V	0.08 0.13	4.7 4.1	3000mA
Siliconix SI 1901	SOT363-6 (2P)	30V	0.480	0.86	200mA unipolar

Layout considerations

For optimal operation of the circuit a careful board layout is important, because of the combination of high current chopper operation coupled with high accuracy threshold comparators. Please pay special attention to massive grounding. Depending on the required motor current, either a single massive ground plane or a ground plane plus star connection of the power traces may be used. The schematic shows how the high current paths can be routed separately, so that the chopper current does not flow through the system's GND-plane. Tie the TMC239's AGND and GND to the GND plane. Additionally, use enough filtering capacitors located near to the board's power supply input and small ceramic capacitors near to the power supply connections of the TMC239. Use low inductance sense resistors, or add a ceramic capacitor in parallel to each resistor to avoid high voltage spikes. In some applications it may become necessary to introduce additional RC-filtering into the VT and SRA / SRB line, as shown in the schematic, to prevent spikes from triggering the short circuit protection or the chopper comparator. If you want to take advantage of the thermal protection and diagnosis, ensure, that the power transistors are very close to the package, and that there is a good thermal contact between the TMC239 and the external transistors. Please be aware, that long or thin GND traces to the sense resistors may add substantial resistance and thus reduce output current. The same is valid for the high side shunt resistor.

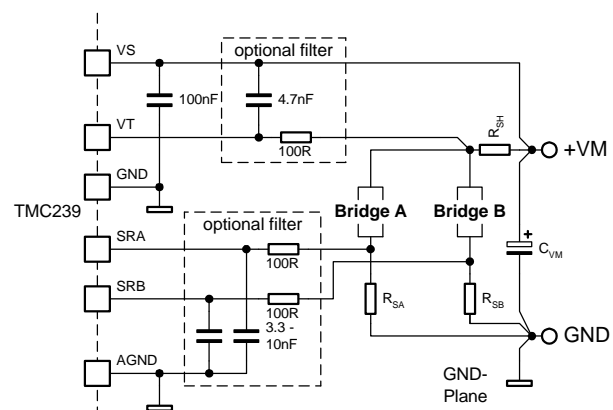

Using additional power drivers

For higher voltage and higher output current it is possible to add external MOSFET gate drivers. Both, dedicated transistor drivers are suitable, as well as a circuit based on standard HCMOS drivers. It is important to understand the function of dedicated gate drivers for N-channel transistors: Since the chopping also can be stopped in open load conditions, the gate drive circuit for the upper transistors should allow for continuous ON conditions. In the schematic below this is satisfied by attaching a weak additional charge pump oscillator and pumping the VS up to the high voltage supply. Do not enable the TMC239, before the gate driver capacitors are charged to an appropriate voltage. A current sensing comparator in the VM line pulling down the VT pin by some 100mV on overcurrent can be added, if required. Since the TMC239 senses switch-off of the transistor gates to ensure break-before-make operation, the break before-make-delays can be increased by capacitive loading of its transistor drive outputs. The capacitors CdHS and CdLS are charged / discharged with the nominal gate current. The opposite output is not enabled, before the switching-off output has been discharged to 0.5V. Both circuits do not show decoupling capacitors and further details.

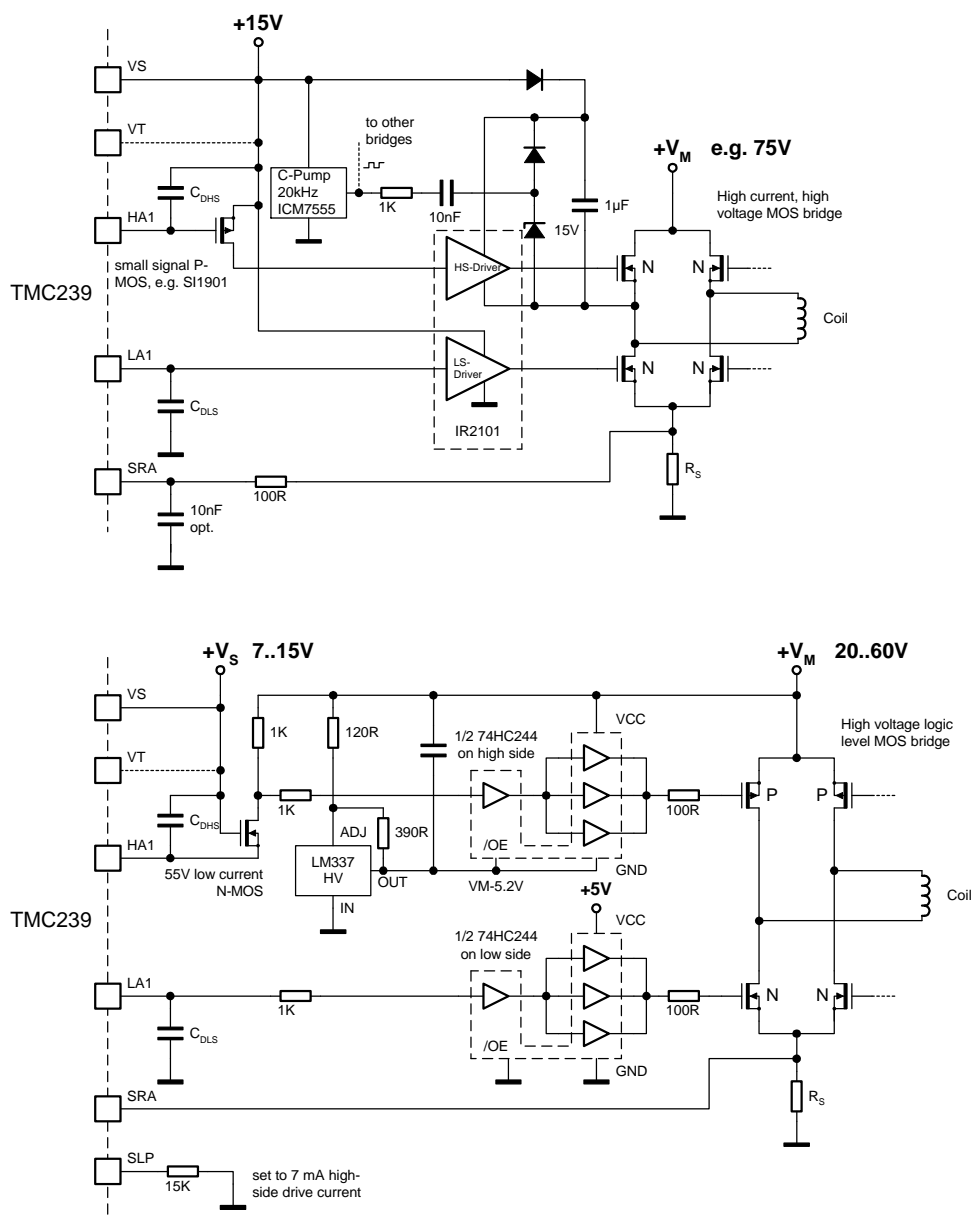

Serial interface word assignment

The SPI data word sets the current and polarity for both coils. By applying consecutive values, describing a sine and a cosine wave, the motor can be driven in microsteps. Every microstep is initiated by its own telegram. Please refer to the description of the analog mode for details on the waveforms required.

Serial data word transmitted to TMC239

(MSB transmitted first)

Bit	Name	Function	Remark
11	MDA	mixed decay enable phase A	"1" = mixed decay
10	CA3	current bridge A.3	MSB
9	CA2	current bridge A.2	
8	CA1	current bridge A.1	
7	CA0	current bridge A.0	LSB
6	PHA	polarity bridge A	"0" = current flow from OA1 to OA2
5	MDB	mixed decay enable phase B	"1" = mixed decay
4	CB3	current bridge B.3	MSB
3	CB2	current bridge B.2	
2	CB1	current bridge B.1	
1	CB0	current bridge B.0	LSB
0	PHB	polarity bridge B	"0" = current flow from OB1 to OB2

Serial data word transmitted from TMC239

(MSB transmitted first)

Bit	Name	Function	Remark
11	0	always "0"	
10	0	always "0"	
9	0	always "0"	
8	1	always "1"	
7	OT	overtemperature	"1" = chip off due to overtemperature
6	OTPW	temperature prewarning	"1" = prewarning temperature exceeded
5	UV	driver undervoltage	"1" = undervoltage on VS
4	OCHS	overcurrent high side	3 PWM cycles with overcurrent within 63 PWM cycles
3	OLB	open load bridge B	no PWM switch off for 14 oscillator cycles
2	OLA	open load bridge A	no PWM switch off for 14 oscillator cycles
1	OCA	overcurrent bridge B low side	3 PWM cycles with overcurrent within 63 PWM cycles
0	OCB	overcurrent bridge A low side	3 PWM cycles with overcurrent within 63 PWM cycles

Typical winding current values

Current setting CA3..0 / CB3..0	Percentage of current	Typical trip voltage of the current sense comparator (internal reference or analog input voltage of 2V is used)
0000	0%	0 V (bridge continuously in slow decay condition)
0001	6.7%	23 mV
0010	13.3%	45 mV
...	...	
1110	93.3%	317 mV
1111	100%	340 mV

The current values correspond to a standard 4 Bit DAC, where 100%=15/16. The contents of all registers is cleared to "0" on power-on reset or disable via the ENN pin, bringing the chip to a low power standby mode. All SPI inputs have Schmitt-Trigger function.

Base current control via INA and INB

In SPI mode, the chip can use an external reference voltage for each DAC. This allows the adaptation to different motors. This mode is enabled by tying pin ANN to GND. A 2.0V input voltage gives full scale current of 100%. In this case, the typical trip voltage of the current sense comparator is determined by the input voltage and the DAC current setting (see table above) as follows:

$$V_{TRIP,A} = 0.17 V_{INA} \times \text{"percentage SPI current setting A"}$$

$$V_{TRIP,B} = 0.17 V_{INB} \times \text{"percentage SPI current setting B"}$$

A maximum of 3.0V V_{IN} is possible. Multiply the percentage of base current setting and the DAC table to get the overall coil current. It is advised to operate at a high base current setting, to reduce the effects of noise voltages. This feature allows a high resolution setting of the required motor current using an external DAC or PWM-DAC.

Controlling the power down mode via the SPI interface

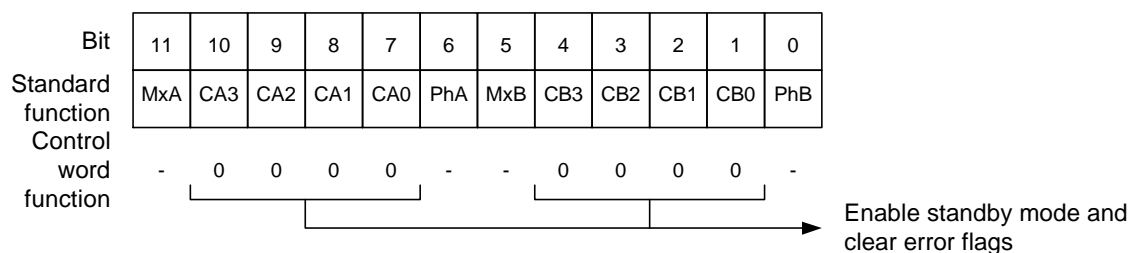

Programming current value "0000" for both coils at a time clears the overcurrent flags and switches the TMC239 into a low current standby mode with coils switched off.

Open load detection

Open load is signaled, whenever there are more than 14 oscillator cycles without PWM switch off. Note that open load detection is not possible while coil current is set to "0000", because the chopper is off in this condition. The open load flag will then always be read as inactive ("0"). During overcurrent conditions, the open load flags also become active!

Overcurrent protection and diagnosis

The TMC239 uses the current sense resistors on the low side to detect an overcurrent: Whenever a voltage above 0.61V is detected, the PWM cycle is terminated at once and all transistors of the bridge are switched off for the rest of the PWM cycle. The error counter is increased by one. If the error

counter reaches 3, the bridge remains switched off for 63 PWM cycles and the error flag is read as "active". The user can clear the error condition in advance by clearing the error flag. The error counter is cleared, whenever there are more than 63 PWM cycles without overcurrent. There is one error counter for each of the low side bridges, and one for the high side. The overcurrent detection is inactive during the blank pulse time for the corresponding bridge.

The high side comparator detects a short to GND or an overcurrent, whenever the voltage between VS and VT becomes higher than 0.15 V at any time, except for the blank time period which is logically ORed for both bridges. Here all transistors become switched off for the rest of the PWM cycle, because the bridge with the failure is unknown.

The overcurrent flags can be cleared by disabling and re-enabling the chip either via the ENN pin or by sending a telegram with both current control words set to "0000". In high side overcurrent conditions the user can determine which bridge sees the overcurrent, by selectively switching on only one of the bridges with each polarity (therefore the other bridge should remain programmed to "0000").

Overtemperature protection and diagnosis

The circuit switches off all output power transistors during an overtemperature condition. The overtemperature flag should be monitored to detect this condition. The circuit resumes operation after cool down below the temperature threshold.

Enable pin behavior

During disable conditions the circuit switches off all output power transistors and goes into a low current shutdown mode. All register contents is cleared to "0", and all status flags are cleared.

Chopper cycle

The TMC239 uses a quiet fixed frequency chopper. Both coils are chopped with a phase shift of 180 degrees. The mixed decay option is realized as a self stabilizing system (pat. fi.), by shortening the fast decay phase, if the ON phase becomes longer. It is advised to enable this for each phase during the second half of each microstepping half-wave, when the current is meant to decrease. This leads to less motor resonance, especially at medium velocities. With low velocities or during standstill mixed decay should be switched off. The mixed decay mode can also be enabled when output current is near to zero, to reduce the minimum motor current which can be achieved.

When polarity is changed on one bridge, the PWM cycle on that bridge becomes restarted at once.

Fast decay switches off both upper transistors, while enabling the lower transistor opposite to the selected polarity. Slow decay always enables both lower side transistors.

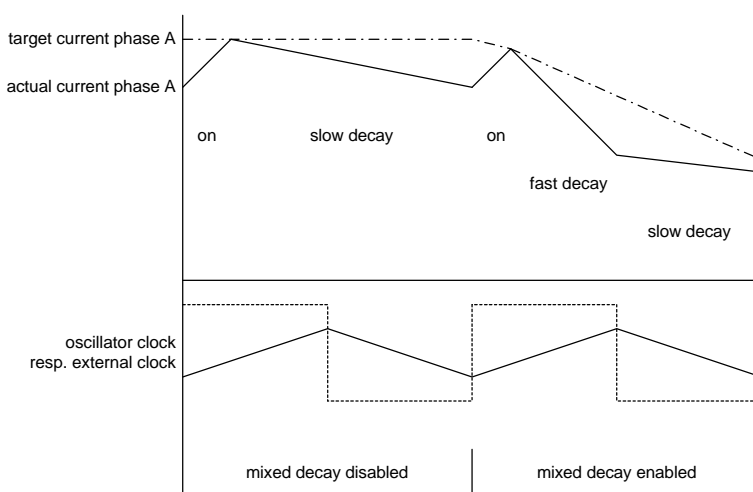

Blank time

The TMC239 uses a digital blanking pulse for the current chopper comparators. This prevents current spikes, which can occur during switching action due to capacitive loading, from terminating the chopper cycle. The lowest possible blanking time gives the best results for microstepping: A long blank time leads to a long minimum turn-on time, thus giving an increased lower limit for the current. Please remark, that the blank time should cover both, switch-off time of the lower side transistors and turn-on time of the upper side transistors plus some time for the current to settle. Thus the complete switching duration should never exceed 1.5 μ s. With slow external power stages it will become necessary to add additional RC-filtering for the sense resistor inputs.

The TMC239 allows to adapt the blank time to the load conditions and to the selected slope in four steps:

Blank time settings

BL2	BL1	Typical blank time
GND	GND	0.6 μ s
GND	VCC	0.9 μ s
VCC	GND	1.2 μ s
VCC	VCC	1.5 μ s

Standby and shutdown mode

The circuit can be put into a low power standby mode by the user, or, automatically goes to standby on Vcc undervoltage conditions. Before entering standby mode, the TMC239 switches off all power transistors, and holds their gates in a disable condition using high ohmic resistors. In standby mode the oscillator becomes disabled and the oscillator pin is held at a low state. The standby mode is available via the interface in SPI-mode and via the ENN pin in non-SPI mode.

The shutdown mode can only be entered in SPI-mode using the ENN pin. In shutdown all internal reference voltages also become switched off and the SPI circuit is held in reset.

Classical non-SPI control mode (stand alone mode)

The driver can be controlled by analog current control signals and digital phase signals. To enable this mode, tie pin SPE to GND. In this mode, the SPI interface is disabled and the SPI input pins have alternate functions. The internal DACs are forced to "1111".

Pin functions in stand alone mode

Pin	Stand alone mode name	Function in stand alone mode
SPE		Tie to GND to enable stand alone mode
ANN	MDAN	Enable mixed decay for bridge A (low = enable)
SCK	MDBN	Enable mixed decay for bridge B (low = enable)
SDI	PHA	Polarity bridge A (low = current flow from output OA1 to OA2)
CSN	PHB	Polarity bridge B (low = current flow from output OB1 to OB2)
SDO	ERR	Error output (high = overcurrent on any bridge, or overtemperature). In this mode, the pin is never tristated.
ENN		Standby mode (high active), high causes a low power mode of the device. Setting this pin high also resets all error conditions.
INA, INB		Current control for bridge A, resp. bridge B. Refer to AGND. The sense resistor trip voltage is 0.34V when the input voltage is 2.0V. Maximum input voltage is 3.0V.

Input signals for microstep control in stand alone mode

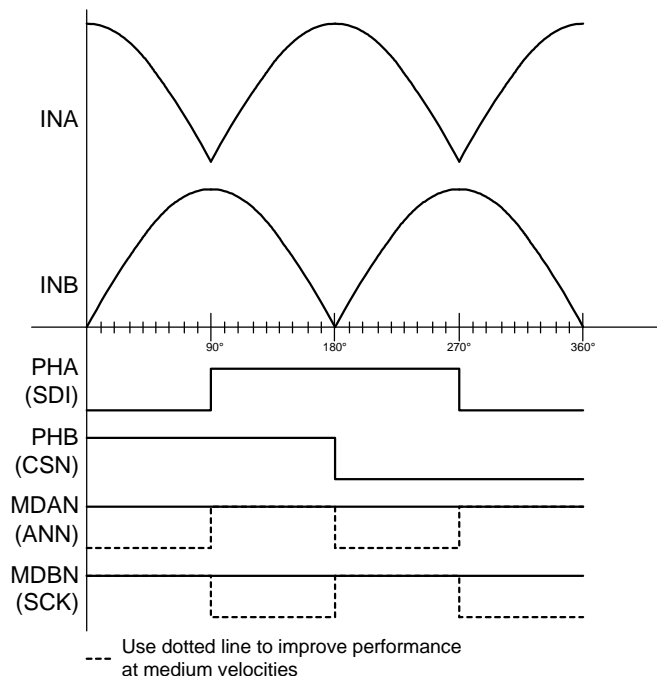

Unipolar operation

The TMC239 can also be used in an unipolar motor application with microstepping. In this configuration, only the four upper power transistors are required.

Differences of short circuit behavior in unipolar operation mode

Since there is no possibility to disable a short to VS condition, the circuit is not completely short circuit proof. In a low cost application a motor short would be covered, just using the bottom sense resistors (see schematic).

Differences in chopper cycle in unipolar operation mode

In unipolar mode, one of the upper side transistors is chopped, depending on the phase polarity. Slow decay mode always means, that both transistors are disabled. There is no difference between slow and fast decay mode, and the mixed decay control bits are "don't care". The transistors have to stand an off voltage, which is slightly higher than the double of the supply voltage. Voltage decay in the coil can be adapted to the application by adding additional diodes and a zener diode to feed back coil current in flyback conditions to the supply.

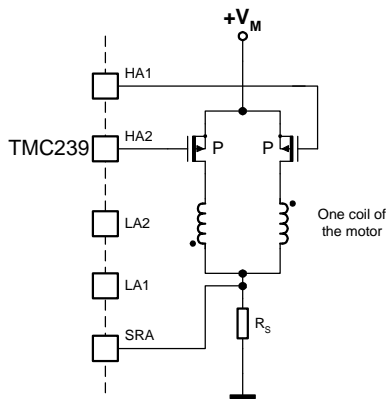

Calculation of the external components

Sense resistor

Choose an appropriate sense resistor (R_S) to set the desired motor current. The maximum motor current is reached, when the coil current setting is programmed to "1111". This results in a current sense trip voltage of 0.34V when the internal reference or a reference voltage of 2V is used.

When operating your motor in fullstep mode, the maximum motor current is as specified by the manufacturer. When operating in sinestep mode, multiply this value by 1.41 for the maximum current (I_{max}).

$$R_S = V_{TRIP} / I_{max}$$

In a typical application:

$$R_S = 0.34V / I_{max}$$

R_S : Current sense resistor of bridge A, B
 V_{TRIP} : Programmed trip voltage of the current sense comparators
 I_{max} : Desired maximum coil current

Examples for sense resistor settings

R_S	I_{max}
0.47 Ω	723mA
0.33 Ω	1030mA
0.22 Ω	1545mA

High side overcurrent detection resistor R_{SH}

The TMC239 detects an overcurrent to ground, when the voltage between VS and VT exceeds 150mV. The high side overcurrent detection resistor should be chosen in a way that 100mV voltage drop are not exceeded between VS and VT, when both coils draw the maximum current. In a sinestep application, this is when sine and cosine wave have their highest sum, i.e. at 45 degrees, corresponding to 1.41 times the maximum current setting for one coil. In a fullstep application this is the double coil current.

In a microstep application:

$$R_{SH} = 0.1V / (1.41 \times I_{max})$$

In a fullstep application:

$$R_{SH} = 0.1V / (2 \times I_{max})$$

R_{SH} : High side overcurrent detection resistor
 I_{max} : Maximum coil current

However, if the user desires to use higher resistance values, a voltage divider in the range of 10 Ω to 100 Ω can be used for VT. This might also be desired to limit the peak short to GND current, as described in the following chapter.

Making the circuit short circuit proof

In practical applications, a short circuit does not describe a static condition, but can be of very different nature. It typically involves inductive, resistive and capacitive components. Worst events are unclamped switching events, because huge voltages can build up in inductive components and result in a high energy spark going into the driver, which can destroy the power transistors. The same is true when disconnecting a motor during operation: Never disconnect the motor during operation!

There is no absolute protection against random short circuit conditions, but pre-cautions can be taken to improve robustness of the circuit:

In a short condition, the current can become very high before it is interrupted by the short detection, due to the blanking during switching and internal delays. The high-side transistors allow full current flowing for the selected blank time. The lower the external inductivity, the faster the current climbs. If inductive components are involved in the short, the same current will shoot through the low-side resistor and cause a high negative voltage spike at the sense resistor. Both, the high current and the voltage spikes are a danger for the driver and transistors.

Thus there are two things to be done, if short circuits are expected:

1. Protect SRA/SRB inputs using a series resistance
2. Increase R_{SH} to limit maximum transistor current: Use same value as for sense resistors

The second measure effectively limits short circuit current, because the upper driver transistor with its fixed ON gate voltage of 7V forms a constant current source together with its internal resistance and R_{SH} . A positive side effect is, that only one type of low ohmic resistor is required. The drawback is, that power dissipation increases. The schematic shows the modifications to be done.

However, the effectiveness of these measures should be tested in the given application.

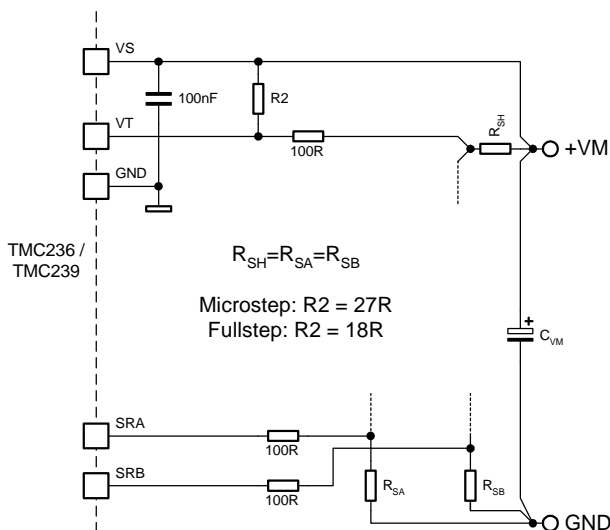

Oscillator capacitor

The PWM oscillator frequency can be set by an external capacitor. The internal oscillator uses a 28kΩ resistor to charge / discharge the external capacitor to a trip voltage of 2/3 Vcc respectively 1/3 Vcc. It can be overdriven using an external CMOS level square wave signal. Do not set the frequency higher than 100kHz and do not leave the OSC terminal open! The two bridges are chopped with a phase shift of 180 degrees at the positive and at the negative edge of the clock signal.

$$f_{osc} \approx \frac{1}{40 \text{ ns} \times C_{osc} [\text{nF}]}$$

f_{osc}: PWM oscillator frequency
C_{osc}: Oscillator capacitor in nF

Table of oscillator frequencies

f _{osc} typ.	C _{osc}
16.7kHz	1.5nF
20.8kHz	1.2nF
25.0kHz	1.0nF
30.5kHz	820pF
36.8kHz	680pF

Please remark, that an unnecessary high frequency leads to high switching losses in the power transistors and in the motor.

Slope Control Resistor

The output-voltage slope of the full bridge is controlled by a constant current gate charge / discharge of the MOSFETs. The charge / discharge current for the high-side MOSFETs can be controlled by an external resistor: A reference current is generated by internally pulling the SLP-Pin to 1.25V via an integrated 4.7K Ω resistor. This current is used to generate the current for switching ON and OFF the upper side transistors.

The gate-driver output current can be set in range of 0.5mA to 25mA by an external resistor:

$$R_{SLP} [k\Omega] \approx \frac{123}{I_{OUT} [mA]} - 4.7$$

R_{SLP} : Slope control resistor
 I_{OUT} : Controlled output current of the low-side MOSFET driver

The SLP-pin can directly be connected to AGND for the fastest output-voltage slope (respectively maximum output current).

The low side MOSFETs are switched on/off with a constant current of typ. +/-15mA into their gate for charge and discharge.

Slope control only affects the upper transistors, and thus the normal direction current, where the circuit feeds energy into the coils. The additional mixed decay slopes, where the coil feeds back current into the power supply, have fixed slope control (corresponding to a 5K Ω to 10K Ω slope control resistor). For applications where electromagnetic emission is very critical, it might be necessary to add additional LC (or capacitor only) filtering on the motor connections.

For these applications emission is lower, if only slow decay operation is used.

Please remark, that there is a trade off between reduced electromagnetic emissions (slow slope) and high efficiency because of low dynamic losses (fast slope).

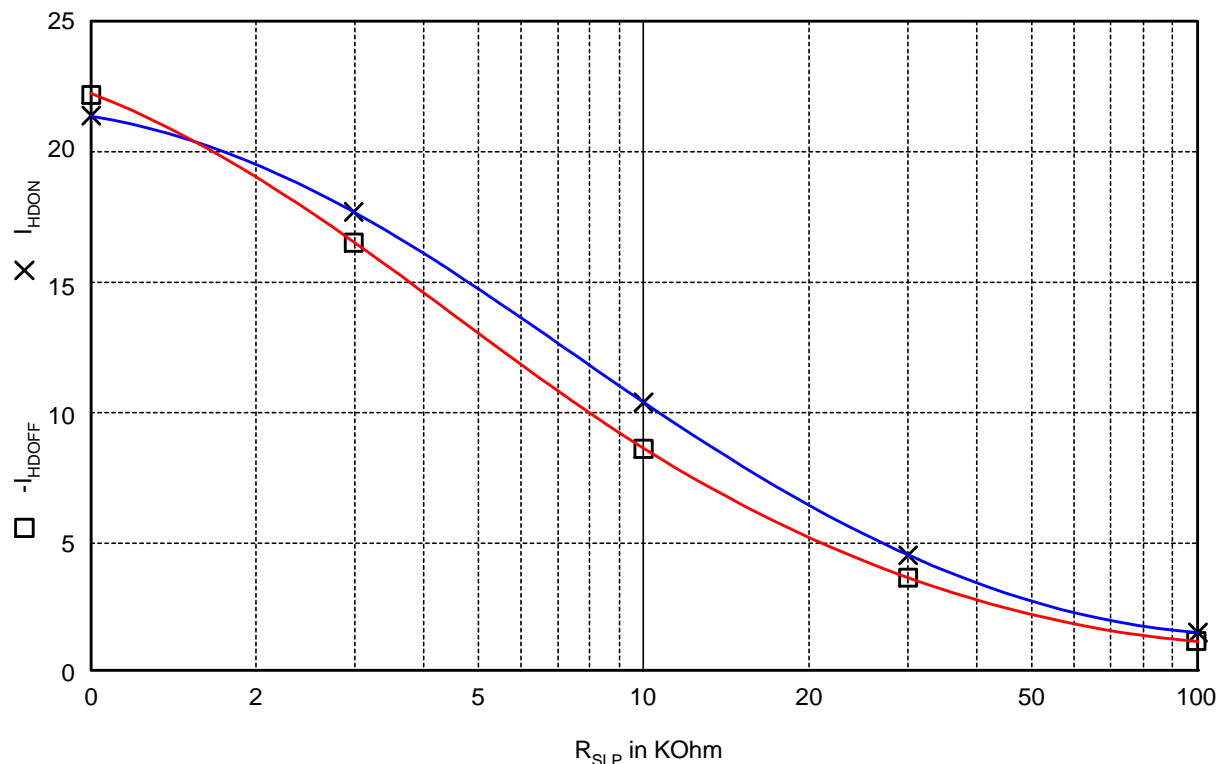

Absolute Maximum Ratings

The maximum ratings may not be exceeded under any circumstances.

Symbol	Parameter	Min	Max	Unit
V _S	Bridge supply voltage		35	V
V _{SM}	Bridge voltage spike / max. 20000s		40	V
V _{CC}	Logic supply voltage	-0.5	6.0	V
I _{OP}	Gate driver peak current (1)		50	mA
V _I	Logic input voltage	-0.3	V _{CC} +0.3V	V
V _{IA}	Analog input voltage	-0.3	V _{CC} +0.3V	V
I _{IO}	Maximum current to / from digital pins and analog inputs		+/-10	mA
V _{VT}	Short-to-ground detector input voltage	V _S -1V	V _S +0.3V	V
T _J	Junction temperature	-40	150	°C
T _{STG}	Storage temperature	-55	150	°C

(1) Internally limited

Electrical Characteristics

Operational Range

Symbol	Parameter	Min	Max	Unit
T _{AI}	Ambient temperature industrial (1) TMC 239	-25	125	°C
T _{AA}	Ambient temperature automotive TMC 239	-40	125	°C
T _J	Junction temperature	-40	140	°C
V _S	Bridge supply voltage	7	30	V
V _{CC}	Logic supply voltage	3.1	5.5	V
f _{CLK}	Chopper clock frequency		100	kHz

(1) The circuit can be operated up to 140°C, but output power might derate.

DC Characteristics

DC characteristics contain the spread of values guaranteed within the specified supply voltage and temperature range unless otherwise specified. Typical characteristics represent the average value of all parts.

Logic supply voltage: $V_{CC} = 3.0\text{ V} \dots 5.5\text{ V}$, Junction temperature: $T_J = -40^\circ\text{C} \dots 140^\circ\text{C}$,
 Bridge supply voltage: $V_S = 7\text{ V} \dots 30\text{ V}$ (unless otherwise specified)

Symbol	Parameter	Conditions	Min	Typ	Max	Unit
I_{LDON}	Gate drive current low side switch ON	$V_{LD} < 4\text{V}$	8.5	12	20	mA
I_{LDOFF5}	Gate drive current low side switch OFF	$V_{LD} > 3\text{V}$ $V_{CC} = 5\text{V}$	-15	-25	-35	mA
I_{LDOFF3}	Gate drive current low side switch OFF	$V_{LD} > 3\text{V}$ $V_{CC} = 3.3\text{V}$	-10	-15	-20	mA
I_{HDON}	Gate drive current high side switch ON	$R_{SLP} = 0\text{K}$ $V_S - V_{HD} < 4\text{V}$	-20	-22.5	-35	mA
I_{HDOFF}	Gate drive current high side switch OFF	$R_{SLP} = 0\text{K}$ $V_S - V_{HD} > 2\text{V}$	15	22.5	25	mA
V_{GH1}	Gate drive voltage high side ON	$V_S > 8\text{V}$	-5.1	-6	-8	V
V_{GL1}	Gate drive voltage low side ON	$V_S > 8\text{V}$	5.1	6.1	8	V
V_{GH0}	Gate drive voltage high side OFF			0	-0.5	V
V_{GL0}	Gate drive voltage low side OFF			0	0.5	V
V_{GCL}	Gate driver clamping voltage	$-I_H / I_L = 20\text{mA}$	12	16	20	V
V_{GCLI}	Gate driver inverse clamping voltage	$-I_H / I_L = -20\text{mA}$		-0.8		V
V_{CCUV}	VCC undervoltage		2.5	2.7	2.9	V
V_{CCOK}	VCC voltage o.k.		2.7	2.9	3.1	V
I_{CC}	VCC supply current	$f_{osc} = 25\text{ kHz}$	0.5	0.7	1.1	mA
I_{CCSTB}	VCC supply current standby			0.43	0.7	mA
I_{CCSD}	VCC supply current shutdown	$ENN = 1$		<1	20	μA
V_{SUV}	VS undervoltage		5.5	5.9	6.2	V
V_{CCOK}	VS voltage o.k.		6.1	6.4	6.7	V
I_{SSD}	VS supply current shutdown or standby	$V_S = 14\text{V}$		28		μA
V_{IH}	High input voltage (all digital inputs)		2.2		$V_{CC} + 0.3\text{ V}$	V
V_{IL}	Low input voltage (all digital inputs)		-0.3		0.7	V
V_{IHYS}	Input voltage hysteresis (all digital inputs)		100	300	500	mV
V_{OH}	High output voltage (output SDO)	$-I_{OH} = 1\text{mA}$	$V_{CC} - 0.6$	$V_{CC} - 0.2$	V_{CC}	V
V_{OL}	Low output voltage (output SDO)	$I_{OL} = 1\text{mA}$	0	0.1	0.4	V

$-I_{ISL}$	Low input current (all digital inputs)	$V_I = 0$ $V_{CC} = 3.3V$ $V_{CC} = 5.0V$	2	10 25	70	μA μA μA
$-I_{IEL}$	Low input current (input ENN)	$V_I = 0$ $V_{CC} = 3.3V$ $V_{CC} = 5.0V$	10	20 30	50	μA μA μA
V_{OSCH}	High input voltage threshold (input OSC)		tbd	2/3 VCC	tbd	V
V_{OSCL}	Low input voltage threshold (input OSC)		tbd	1/3 VCC	tbd	V
V_{VTD}	VT threshold voltage (referenced to VS)		-130	-155	-180	mV
V_{SRT}	SRA / SRB 100% setting threshold using internal reference or 2V at INA / INB		311	345	380	mV
V_{SRS}	SRA / SRB overcurrent detection threshold		570	615	660	mV
V_{SROFFS}	SRA / SRB comparator offset voltage		-6	0	6	mV
R_{INAB}	INA / INB input resistance	$V_{in} \leq 3 V$	200	264	300	k Ω

AC Characteristics

AC characteristics contain the spread of values guaranteed within the specified supply voltage and temperature range unless otherwise specified. Typical characteristics represent the average value of all parts.

Logic supply voltage: $V_{CC} = 3.3V$,
Ambient temperature: $T_A = 27^\circ C$,

Bridge supply voltage: $V_S = 14.0V$,
External MOSFET gate capacity = 3.2nC

Symbol	Parameter	Conditions	Min	Typ	Max	Unit
f_{OSC}	Oscillator frequency using internal oscillator	$C_{OSC} = 1nF$ $\pm 1\%$	20	25	31	kHz
T_{BL}	Blank time	$BL1, BL2 = V_{CC}$	1.35	1.5	1.65	μs
T_{ONMIN}	Minimum PWM on-time	$BL1, BL2 =$ GND		0.7		μs

Thermal Protection

Symbol	Parameter	Conditions	Min	Typ	Max	Unit
T_{JOT}	Thermal shutdown		143	150	160	$^\circ C$
T_{JOTHYS}	T_{JOT} hysteresis			10		$^\circ C$
T_{JWT}	Prewarning temperature		133	141	151	$^\circ C$
T_{JWTHYS}	T_{JWT} hysteresis			19		$^\circ C$

Interface Timing

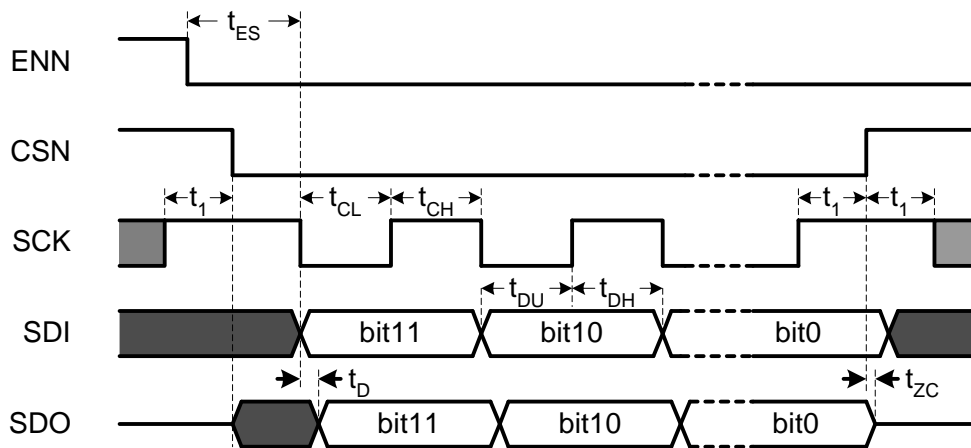

Propagation times

(3.0 V ≤ VCC ≤ 5.5 V, -40°C ≤ Tj ≤ 150°C; V_{IH} = 2.8V, V_{IL} = 0.5V; tr, tf = 10ns; C_L = 50pF, unless otherwise specified)

Symbol	Parameter	Conditions	Min	Typ	Max	Unit
f _{SCK}	SCK frequency	ENN = 0	DC		4	MHz
t ₁	SCK stable before and after CSN change		50			ns
t _{CH}	Width of SCK high pulse		100			ns
t _{CL}	Width of SCK low pulse		100			ns
t _{DU}	SDI setup time		40			ns
t _{DH}	SDI hold time		50			ns
t _D	SDO delay time	C _L = 50pF		37	80	ns
t _{zc}	CSN high to SDO high impedance			50		ns
t _{ES}	ENN to SCK setup time		tbd			μs

Application note: Extending the microstep resolution

For some applications it might be desired to have a higher microstep resolution, while keeping the advantages of control via the serial interface. The following schematic shows a solution, which adds two LSBs by selectively pulling up the SRA / SRB pin by a small voltage difference. It assumes a full scale sense voltage of 340mV. The circuit still takes advantage of completely switching off of the coils when the internal DAC bits are set to "0000". This results in the following comparator trip voltages:

Current setting (MSB first)	Trip voltage
0000xx	0 V
000111	5.8 mV
000110	11.5 mV
000101	17.3 mV
000100	23 mV
...	
111101	334.2 mV
111100	340 mV

SPI bit	15	14	13	12	11	10	9	8
DAC bit	/B1	/B0	/A1	/A0	MDA	A5	A4	A3
SPI bit	7	6	5	4	3	2	1	0
DAC bit	A2	PHA	MDB	B5	B4	B3	B2	PHB

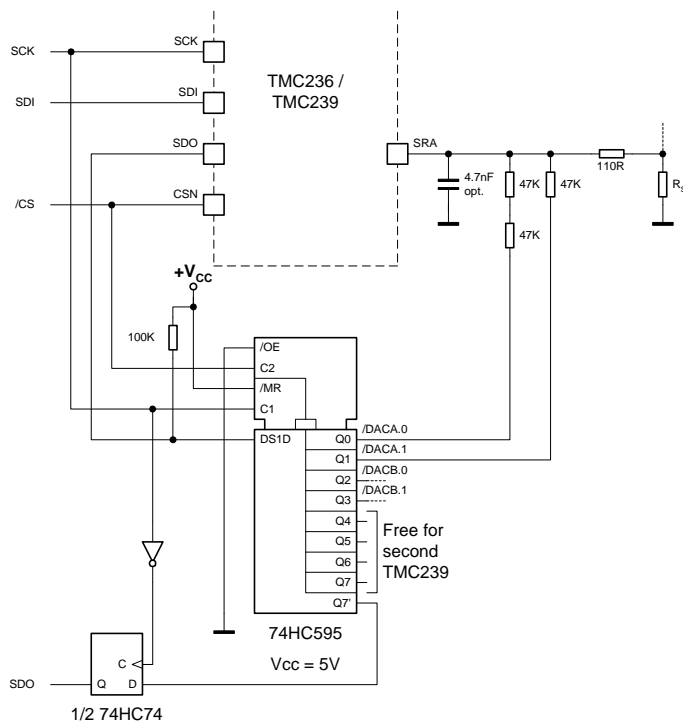

ⁱ SPI is a trademark of Motorola