



DVFL2800D Series

HIGH RELIABILITY HYBRID DC-DC CONVERTERS

DESCRIPTION

The DVFL series of high reliability DC-DC converters is operable over the full military (-55 °C to +125 °C) temperature range with no power derating. Unique to the DVFL series is a magnetic feedback circuit that is radiation immune. Operating at a nominal fixed frequency of 500 kHz, these regulated, isolated units utilize well-controlled undervoltage lockout circuitry to eliminate slow start-up problems. The current sharing function allows a maximum of five units to be connected in parallel to boost the total output power to 5 times. The output voltage is trimmable up to +10% or down -20%.

These converters are designed and manufactured in a facility qualified to ISO9001 and certified to MIL-PRF-38534 and MIL-STD-883.

This product may incorporate one or more of the following U.S. patents:

5,784,266
 5,790,389
 5,963,438
 5,999,433
 6,005,780
 6,084,792
 6,118,673

FEATURES

- High Reliability
- Parallel Up to 5 Units With Current Sharing
- Output Voltage Trim Up +10% or Down -20%
- Wide Input Voltage Range: 16 to 40 Volts per MIL-STD-704
- Up to 120 Watts Output Power
- Radiation Immune Magnetic Feedback Circuit
- NO Use of Optoisolators
- Undervoltage Lockout
- Indefinite Short Circuit Protection
- Current Limit Protection
- Industry Standard Pinout
- Input Transient Voltage: 50 Volts for 1 second
- Radiation Hardened Version Available
- Precision Seam Welded Hermetic Package
- High Power Density: > 80 W/in³
- Custom Versions Available
- Additional Environmental Screening Available
- Meets MIL-STD-461C and MIL-STD-461D EMC Requirements When Used With a DVME28 EMI Filter
- MIL-PRF-38534 Element Evaluated Components

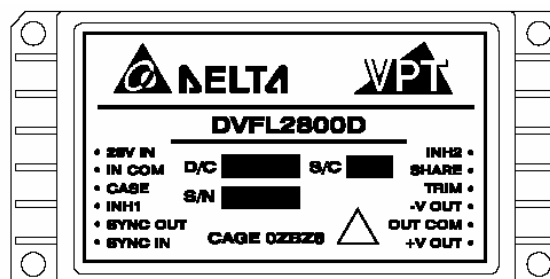

Figure 1 – DVFL2800D DC-DC Converter
 (Not To Scale)

SPECIFICATIONS ($T_{CASE} = -55^{\circ}\text{C}$ to $+125^{\circ}\text{C}$, $V_{IN} = +28\text{V} \pm 5\%$, Full Load⁵, Unless Otherwise Specified)

ABSOLUTE MAXIMUM RATINGS

Input Voltage (Continuous)	40 V _{DC}	Junction Temperature Rise to Case	+15°C
Input Voltage (Transient, 1 second)	50 Volts	Storage Temperature	-65°C to +150°C
Output Power ¹	120 Watts	Lead Solder Temperature (10 seconds)	270°C
Power Dissipation (Full Load, $T_{CASE} = +125^{\circ}\text{C}$)	40 Watts	Weight (Maximum) (No Pin Extensions)	86 Grams

Parameter	Conditions	DVFL2805D			DVFL2812D			Units
		Min	Typ	Max	Min	Typ	Max	
STATIC								
INPUT Voltage ⁴	Continuous	16	28	40	16	28	40	V
	Transient, 1 sec	-	-	50	-	-	50	V
Current	Inhibited 1	-	-	3	-	-	3	mA
	Inhibited 2	-	-	70	-	-	70	mA
	No Load	-	-	140	-	-	140	mA
Ripple Current	Full Load ⁵ , 20Hz to 10MHz	-	-	80	-	-	80	mA _{p-p}
INH1 Pin Input ⁴		0	-	1.5	0	-	1.5	V
INH2 Pin Input ⁴		0	-	1.0	0	-	1.0	V
INH1 Pin Open Circuit Voltage ⁴		10.5	-	13.5	10.5	-	13.5	V
INH2 Pin Open Circuit Voltage ⁴		5.0	-	8.0	5.0	-	8.0	V
UVLO Turn On		14.0	-	16.0	14.0	-	16.0	V
UVLO Turn Off ⁴		11.0	-	14.5	11.0	-	14.5	V
OUTPUT Voltage ⁵	+V _{OUT} $T_{CASE} = 25^{\circ}\text{C}$	4.95	5.00	5.05	11.88	12.00	12.12	V
	+V _{OUT} $T_{CASE} = -55^{\circ}\text{C}$ to $+125^{\circ}\text{C}$	4.925	5.00	5.075	11.82	12.00	12.18	V
	-V _{OUT} $T_{CASE} = 25^{\circ}\text{C}$	4.80	5.00	5.20	11.80	12.00	12.20	V
	-V _{OUT} $T_{CASE} = -55^{\circ}\text{C}$ to $+125^{\circ}\text{C}$	4.75	5.00	5.25	11.52	12.00	12.48	V
Power ^{3,6}	Total	-	-	100	-	-	110	W
	$\pm V_{OUT}$ Either Output	-	-	70	-	-	77	W
Current ^{3,6}	$\pm V_{OUT}$ Either Output	-	-	14	-	-	6.4	A
Ripple Voltage	$\pm V_{OUT}$ Full Load ⁵ , 20Hz to 10MHz	-	-	80	-	-	80	mV _{p-p}
Line Regulation	+V _{OUT} $V_{IN} = 16\text{V}$ to 40V	-	-	20	-	-	20	mV
	-V _{OUT} $V_{IN} = 16\text{V}$ to 40V	-	-	200	-	-	200	mV
Load Regulation	+V _{OUT} No Load to Full Load ⁵	-	-	100	-	-	120	mV
	-V _{OUT} No Load to Full Load ⁵	-	-	200	-	-	200	mV
Cross Regulation	-V _{OUT} V1+ Load 30% - Load 70% V2+ Load 70% - Load 30%	-	-	450	-	-	450	mV
Voltage Trim	Full Load	-20	-	10	-20	-	10	%
Share Pin Voltage ⁴		2.0	-	3.0	2.0	-	3.0	V
EFFICIENCY	Full Load ⁵	73	-	-	80	-	-	%
LOAD FAULT POWER DISSIPATION	Overload ⁴	-	-	80	-	-	80	W
	Short Circuit	-	-	80	-	-	80	W
CAPACITIVE LOAD ⁴		-	-	500	-	-	500	μF
SWITCHING FREQUENCY		425	500	600	425	500	600	kHz
SYNC FREQUENCY RANGE	$V_H - V_L = 5\text{V}$ Duty Cycle = 20% - 80%	500	-	600	500	-	600	kHz
ISOLATION	500 V _{DC} , $T_{CASE} = 25^{\circ}\text{C}$	100	-	-	100	-	-	M Ω
MTBF (MIL-HDBK-217F)	AIF @ $T_c = 55^{\circ}\text{C}$	-	400	-	-	400	-	kHrs

SPECIFICATIONS ($T_{CASE} = -55^{\circ}\text{C}$ to $+125^{\circ}\text{C}$, $V_{IN} = +28\text{V} \pm 5\%$, Full Load⁵, Unless Otherwise Specified)

ABSOLUTE MAXIMUM RATINGS

Input Voltage (Continuous)	40 V_{DC}	Junction Temperature Rise to Case	+15°C
Input Voltage (Transient, 1 second)	50 Volts	Storage Temperature	-65°C to +150°C
Output Power ¹	120 Watts	Lead Solder Temperature (10 seconds)	270°C
Power Dissipation (Full Load, $T_{CASE} = +125^{\circ}\text{C}$)	40 Watts	Weight (Maximum) (No Pin Extensions)	86 Grams

Parameter	Conditions	DVFL2805D			DVFL2812D			Units	
		Min	Typ	Max	Min	Typ	Max		
DYNAMIC									
Load Step Output Transient	$\pm V_{OUT}$	Half Load to Full Load	-	-	400	-	-	500	mV _{PK}
Load Step Recovery ²			-	-	500	-	-	500	μSec
Line Step Output Transient ⁴	$\pm V_{OUT}$	$V_{IN} = 16\text{V}$ to 40V	-	300	600	-	600	1200	mV _{PK}
Line Step Recovery ^{2,4}			-	300	500	-	300	500	μSec
Turn On Delay	$\pm V_{OUT}$	$V_{IN} = 0\text{V}$ to 28V	-	-	20	-	-	20	mSec
Turn On Overshoot			-	-	25	-	-	50	mV _{PK}

- Notes:
1. Dependant on output voltage.
 2. Time for output voltage to settle within 1% of its nominal value.
 3. Derate linearly to 0 at 135°C.
 4. Verified by qualification testing.
 5. Half load at $+V_{OUT}$ and half load at $-V_{OUT}$.
 6. Up to 70% of the total power or current can be drawn from any one of the two outputs.

SPECIFICATIONS ($T_{CASE} = -55^{\circ}C$ to $+125^{\circ}C$, $V_{IN} = +28V \pm 5\%$, Full Load⁵, Unless Otherwise Specified)

ABSOLUTE MAXIMUM RATINGS

Input Voltage (Continuous)	40 V _{DC}	Junction Temperature Rise to Case	+15°C
Input Voltage (Transient, 1 second)	50 Volts	Storage Temperature	-65°C to +150°C
Output Power ¹	120 Watts	Lead Solder Temperature (10 seconds)	270°C
Power Dissipation (Full Load, $T_{CASE} = +125^{\circ}C$)	40 Watts	Weight (Maximum) (No Pin Extensions)	86 Grams

Parameter	Conditions	DVFL2815D			Units
		Min	Typ	Max	
STATIC					
INPUT Voltage ⁴	Continuous	16	28	40	V
	Transient, 1 sec	-	-	50	V
Current	Inhibited 1	-	-	3	mA
	Inhibited 2	-	-	70	mA
	No Load	-	-	140	mA
Ripple Current	Full Load ⁵ , 20Hz to 10MHz	-	-	80	mA _{p-p}
INH1 Pin Input ⁴		0	-	1.5	V
INH2 Pin Input ⁴		0	-	1.0	V
INH1 Pin Open Circuit Voltage ⁴		10.5	-	13.5	V
INH2 Pin Open Circuit Voltage ⁴		5.0	-	8.0	V
UVLO Turn On		14.5	-	16.0	V
UVLO Turn Off ⁴		11.0	-	14.5	V
OUTPUT Voltage ⁵	+V _{OUT} $T_{CASE} = 25^{\circ}C$	14.85	15.00	15.15	V
	+V _{OUT} $T_{CASE} = -55^{\circ}C$ to $+125^{\circ}C$	14.775	15.00	15.225	V
	-V _{OUT} $T_{CASE} = 25^{\circ}C$	14.80	15.00	15.20	V
	-V _{OUT} $T_{CASE} = -55^{\circ}C$ to $+125^{\circ}C$	14.40	15.00	15.60	V
Power ^{3,6}	Total	-	-	120	W
	$\pm V_{OUT}$ Either Output	-	-	84	W
Current ^{3,6}	$\pm V_{OUT}$ Either Output	-	-	5.6	A
Ripple Voltage	$\pm V_{OUT}$ Full Load ⁵ , 20Hz to 10MHz	-	-	80	mV _{p-p}
Line Regulation	+V _{OUT} $V_{IN} = 16V$ to $40V$	-	-	20	mV
	-V _{OUT} $V_{IN} = 16V$ to $40V$	-	-	200	mV
Load Regulation	+V _{OUT} No Load to Full Load ⁵	-	-	120	mV
	-V _{OUT} No Load to Full Load ⁵	-	-	200	mV
Cross Regulation	-V _{OUT} V1+ Load 30% - Load 70% V2+ Load 70% - Load 30%	-	-	450	mV
Voltage Trim	Full Load	-20	-	10	%
Share Pin Voltage ⁴		2.0	-	3.0	V
EFFICIENCY	Full Load ⁵	81	-	-	%
LOAD FAULT POWER DISSIPATION	Overload ⁴	-	-	80	W
	Short Circuit	-	-	80	W
CAPACITIVE LOAD ⁴		-	-	500	μF
SWITCHING FREQUENCY		425	500	600	kHz
SYNC FREQUENCY RANGE	$V_H - V_L = 5V$ Duty Cycle = 20% - 80%	500	-	600	kHz
ISOLATION	500 V _{DC} , $T_{CASE} = 25^{\circ}C$	100	-	-	M Ω
MTBF (MIL-HDBK-217F)	AIF @ $T_c = 55^{\circ}C$	-	400	-	kHrs

SPECIFICATIONS ($T_{CASE} = -55^{\circ}\text{C}$ to $+125^{\circ}\text{C}$, $V_{IN} = +28\text{V} \pm 5\%$, Full Load⁵, Unless Otherwise Specified)

ABSOLUTE MAXIMUM RATINGS

Input Voltage (Continuous)	40 V_{DC}	Junction Temperature Rise to Case	+15°C
Input Voltage (Transient, 1 second)	50 Volts	Storage Temperature	-65°C to +150°C
Output Power ¹	120 Watts	Lead Solder Temperature (10 seconds)	270°C
Power Dissipation (Full Load, $T_{CASE} = +125^{\circ}\text{C}$)	40 Watts	Weight (Maximum) (No Pin Extensions)	86 Grams

Parameter	Conditions	DVFL2815D			Units	
		Min	Typ	Max		
DYNAMIC						
Load Step Output Transient	$\pm V_{OUT}$	Half Load to Full Load	-	-	500	mV _{PK}
Load Step Recovery ²			-	-	500	μSec
Line Step Output Transient ⁴	$\pm V_{OUT}$	$V_{IN} = 16\text{V}$ to 40V	-	600	1200	mV _{PK}
Line Step Recovery ^{2,4}			-	300	500	μSec
Turn On Delay	$\pm V_{OUT}$	$V_{IN} = 0\text{V}$ to 28V	-	-	20	mSec
Turn On Overshoot			-	-	50	mV _{PK}

- Notes:
1. Dependant on output voltage.
 2. Time for output voltage to settle within 1% of its nominal value.
 3. Derate linearly to 0 at 135°C.
 4. Verified by qualification testing.
 5. Half load at $+V_{OUT}$ and half load at $-V_{OUT}$.
 6. Up to 70% of the total power or current can be drawn from any one of the two outputs.

BLOCK DIAGRAM

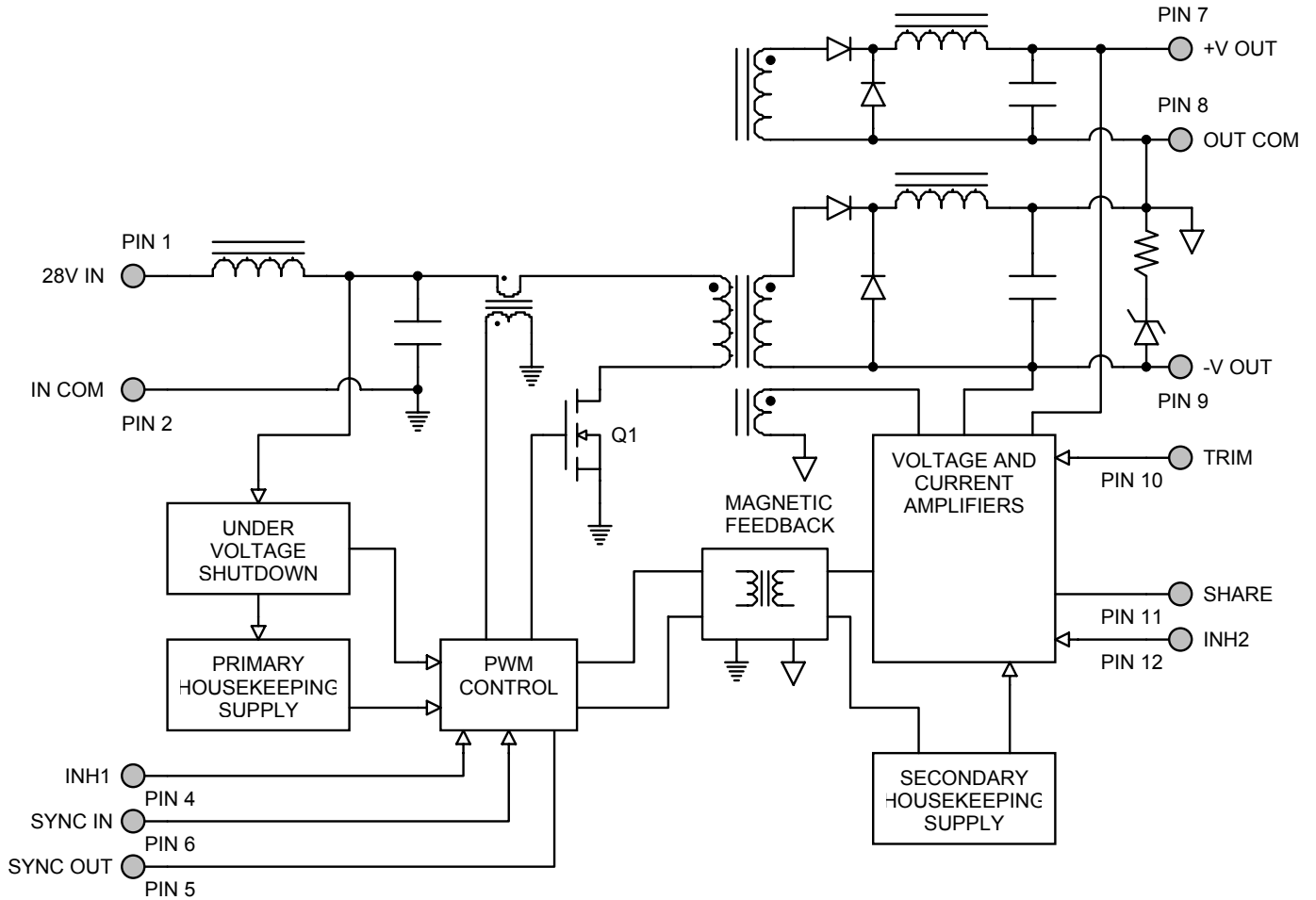

Figure 2

CONNECTION DIAGRAM

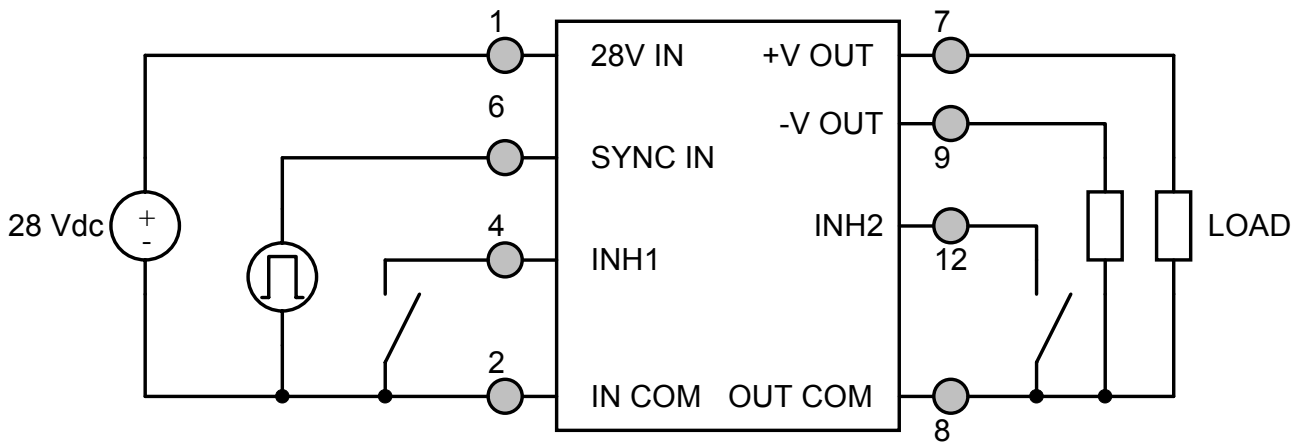

Figure 3

INHIBIT DRIVE CONNECTION DIAGRAM

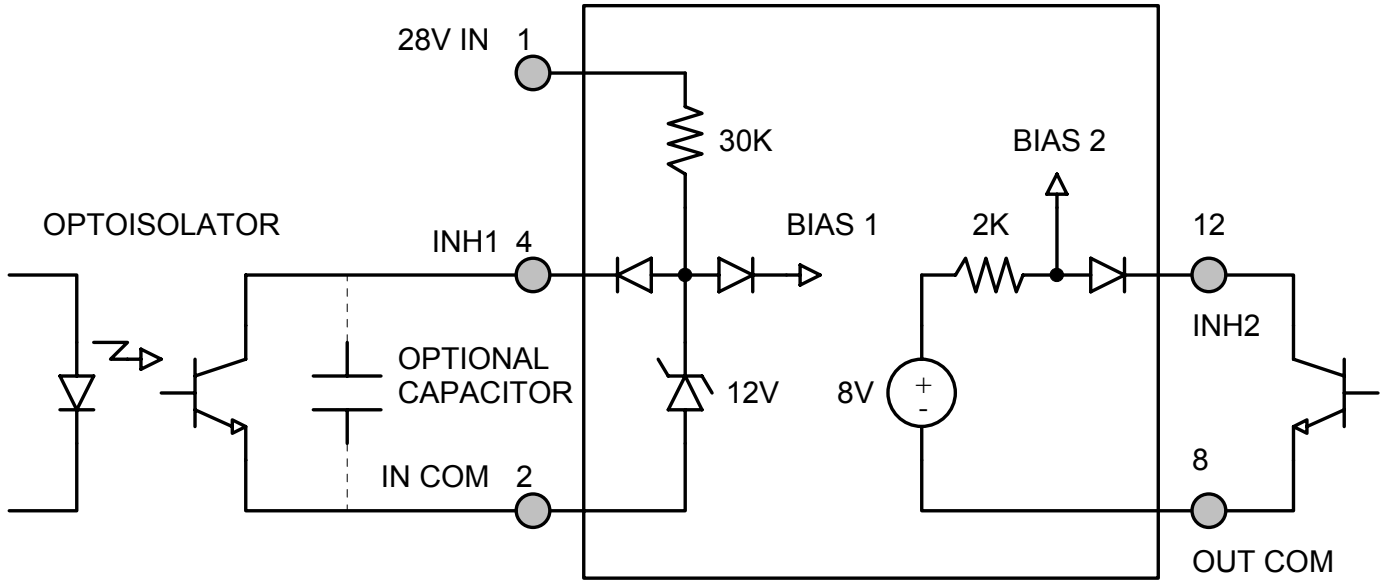

Figure 4 – Isolated Inhibit Drive and Internal Equivalent Circuit
(Shown with optional capacitor for turn-on delay)

EMI FILTER HOOKUP DIAGRAM

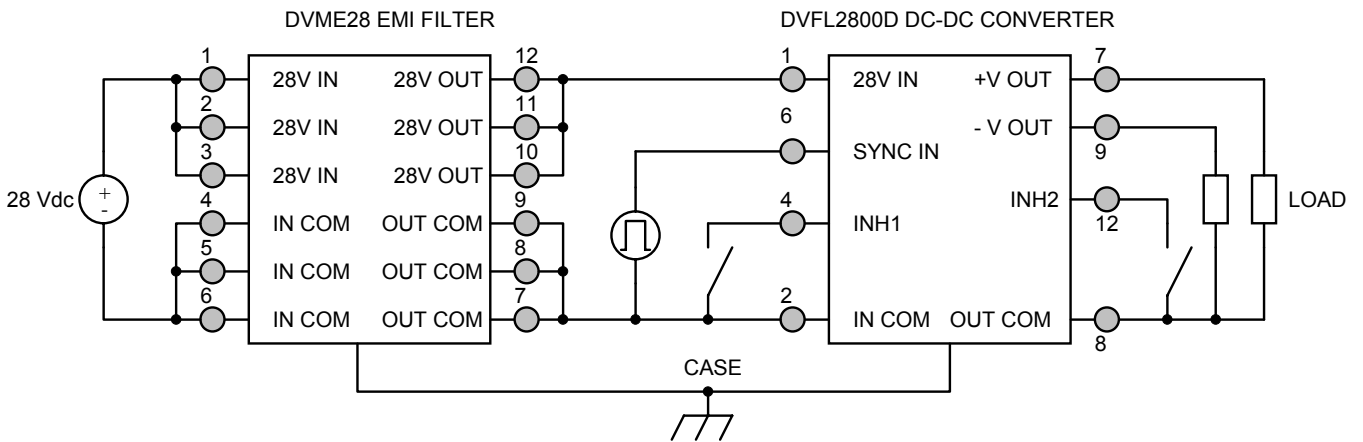

Figure 5 – Converter with EMI Filter

+28 VOLT OUTPUT CONNECTION DIAGRAM

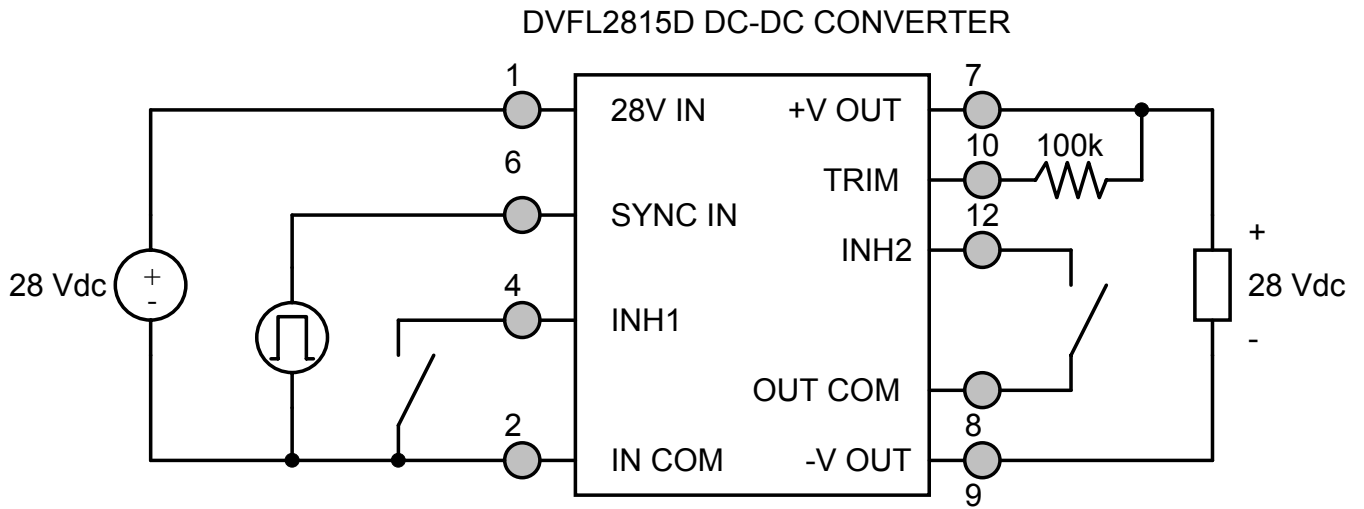

Figure 6: +28 Volt Output Converter Using DVFL2815D Converter

PARALLEL CONNECTION DIAGRAM

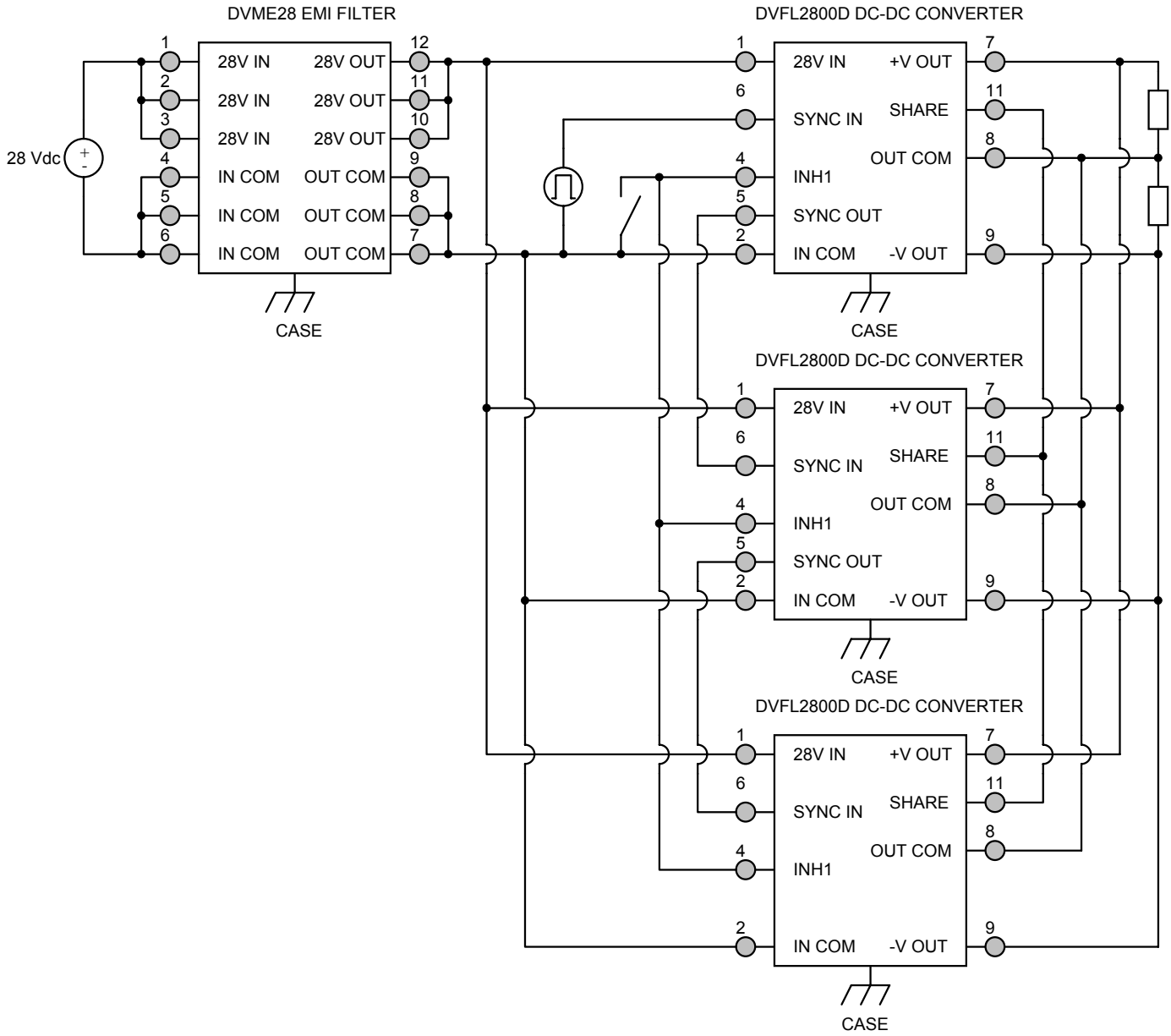
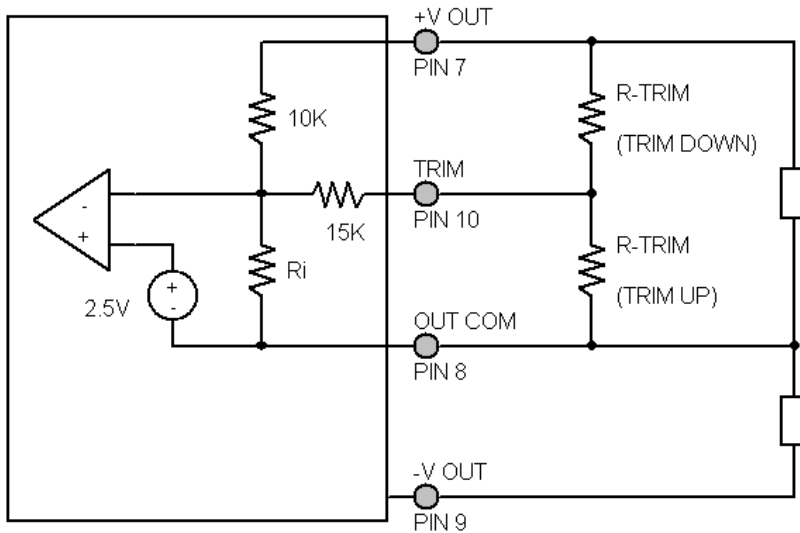

Figure 7 – Current Sharing Parallel Connection for Multiple Converters

OUTPUT VOLTAGE TRIM



The output voltage can be trimmed down by connecting a resistor between the TRIM pin (PIN 10) and the +V OUT pin (PIN 7), or can be trimmed up by connecting a resistor between the TRIM pin (PIN 10) and the OUT COM pin (PIN 8). The maximum trim range is +10% up and -20% down. The appropriate resistor values versus the output voltage are given in the trim table below.

Figure 8 – Output Voltage Trim

DVFL2805D		DVFL2812D		DVFL2815D	
$\pm V_{OUT}$ (V)	R_{TRIM} (Ω)	$\pm V_{OUT}$ (V)	R_{TRIM} (Ω)	$\pm V_{OUT}$ (V)	R_{TRIM} (Ω)
5.5	35k	13.2	5.8k	16.50	1.7k
5.4	47.5k	13.0	10k	16.25	5k
5.3	68.3k	12.8	16.2k	16.00	10k
5.2	110k	12.6	26.6k	15.75	18.3k
5.1	235k	12.4	47.3k	15.50	35k
5.0	-	12.2	109k	15.25	85k
4.9	225k	12.0	-	15.00	-
4.8	100k	11.8	454k	14.75	475k
4.7	58.3k	11.6	213k	14.50	225k
4.6	37.5k	11.4	134k	14.25	142k
4.5	25k	11.2	94k	14.00	100k
4.4	16.7k	11.0	70.1k	13.75	75k
4.3	10.7k	10.8	54.3k	13.50	58.3k
4.2	6.3k	10.6	42.9k	13.25	46.4k
4.1	2.8k	10.4	34.4k	13.00	37.5k
4.0	0	10.2	27.8k	12.75	30.6k
		10.0	22.5k	12.50	25k
		9.8	18.2k	12.25	20.5k
		9.6	14.6k	12.00	16.7k

EFFICIENCY PERFORMANCE CURVES ($T_{CASE} = 25^{\circ}C$, Full Load, Unless Otherwise Specified)

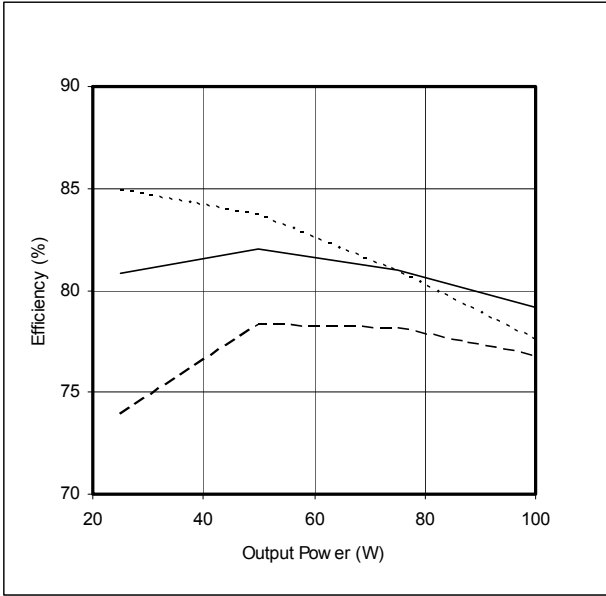
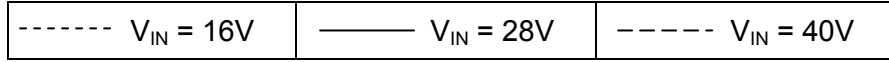

Figure 9 – DVFL2805D
Efficiency (%) vs. Output Power (W)

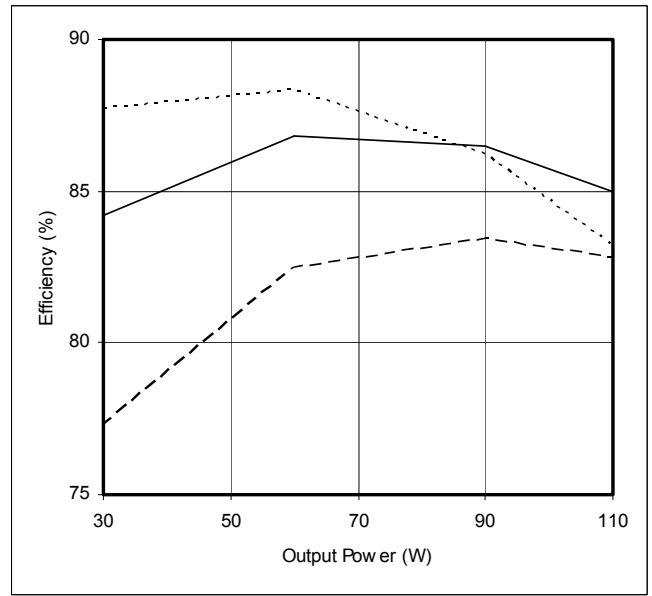

Figure 10 – DVFL2812D
Efficiency (%) vs. Output Power (W)

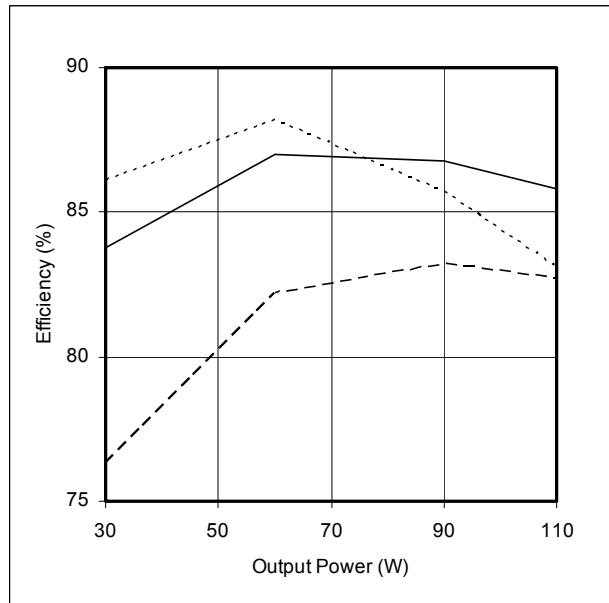

Figure 11 – DVFL2815D
Efficiency (%) vs. Output Power (W)

EMI PERFORMANCE CURVES

($T_{CASE} = 25^{\circ}C$, $V_{IN} = +28V \pm 5\%$, Full Load, Unless Otherwise Specified)

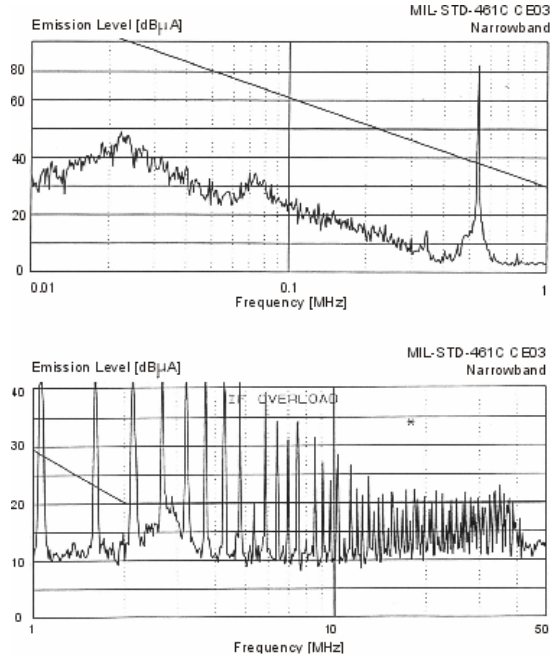

Figure 12 – DVFL2800D without EMI Filter

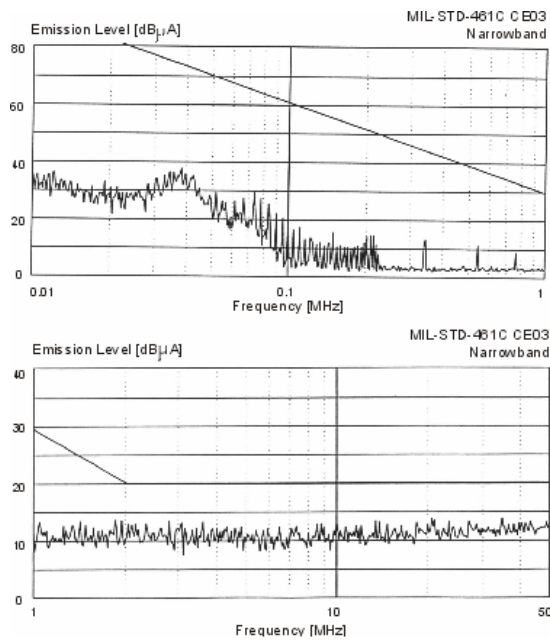
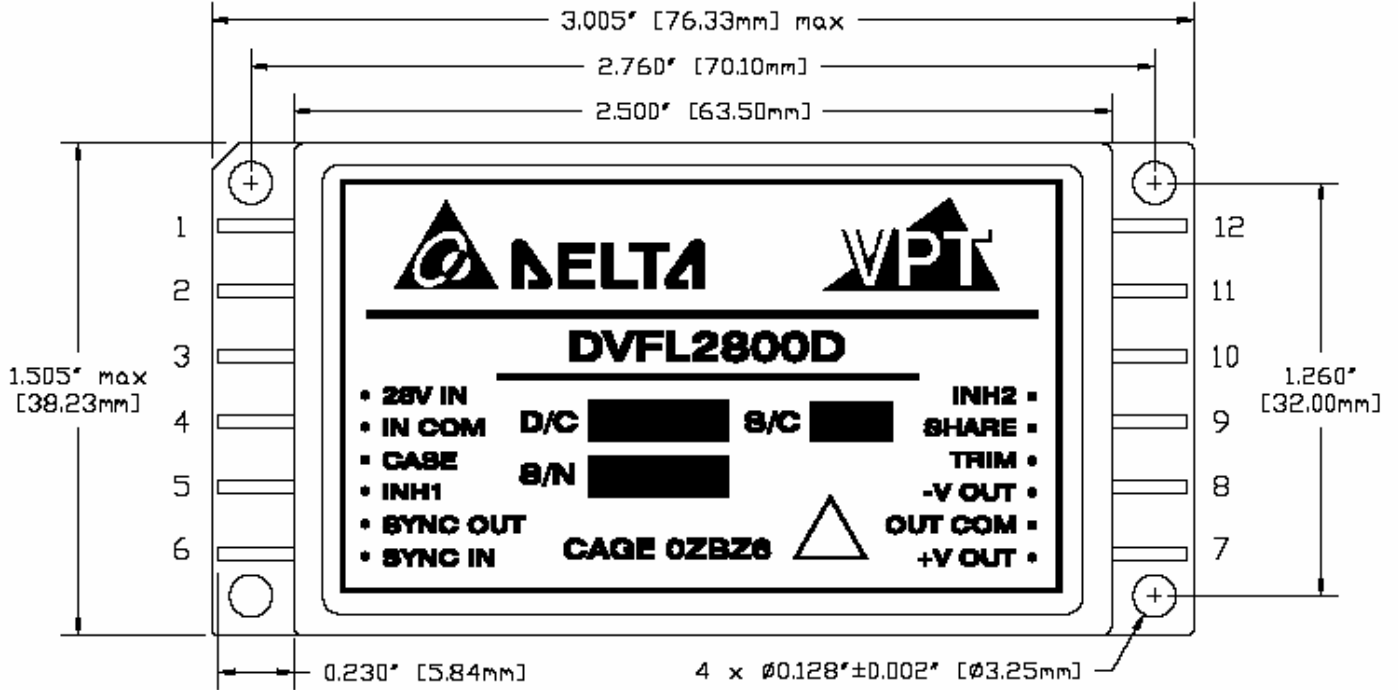
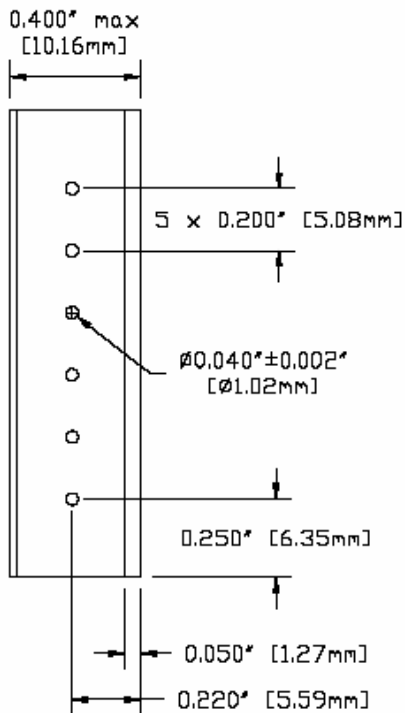

Figure 13 – DVFL2800D with EMI Filter

PACKAGE SPECIFICATIONS



TOP VIEW



SIDE VIEW

PIN	FUNCTION
1	28V IN
2	IN COM
3	CASE
4	INH1
5	SYNC OUT
6	SYNC IN
7	+V OUT
8	OUT COM
9	-V OUT
10	TRIM
11	SHARE
12	INH2

Figure 14 – Package and Pinout
(Pin Length is ± 0.01 ", Other Dimensional Limits are ± 0.005 " Unless Otherwise Stated)

PACKAGE SPECIFICATIONS (DOWN-LEADED)

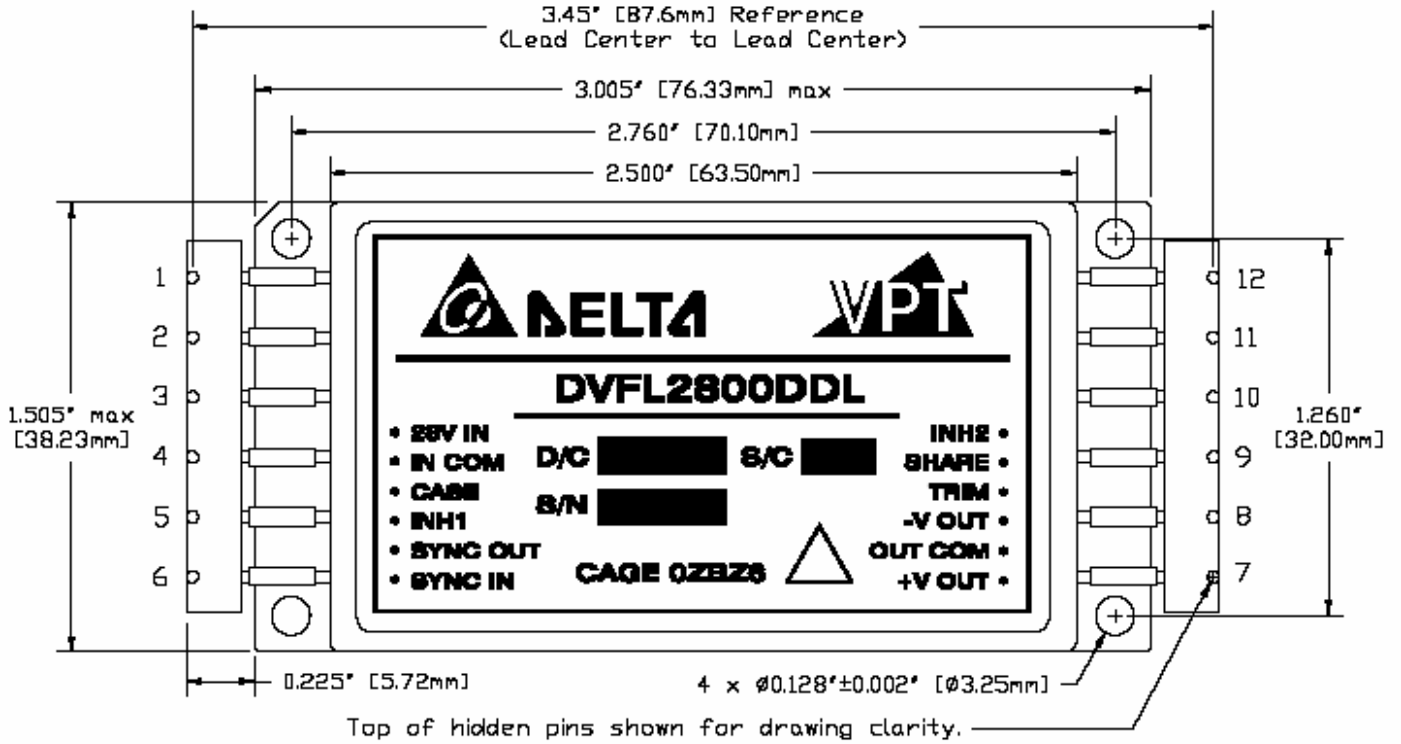

TOP VIEW

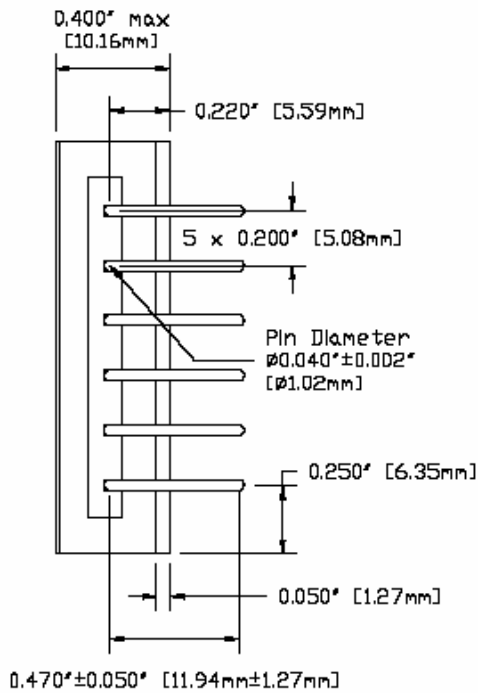

SIDE VIEW

PIN	FUNCTION
1	28V IN
2	IN COM
3	CASE
4	INH1
5	SYNC OUT
6	SYNC IN
7	+V OUT
8	OUT COM
9	-V OUT
10	TRIM
11	SHARE
12	INH2

Figure 15 – Package and Pinout (With Down-Leaded Pin Extensions Added)
(Pin Length is ± 0.01 ", Other Dimensional Limits are ± 0.005 " Unless Otherwise Stated)

PACKAGE SPECIFICATIONS (UP-LEADED)

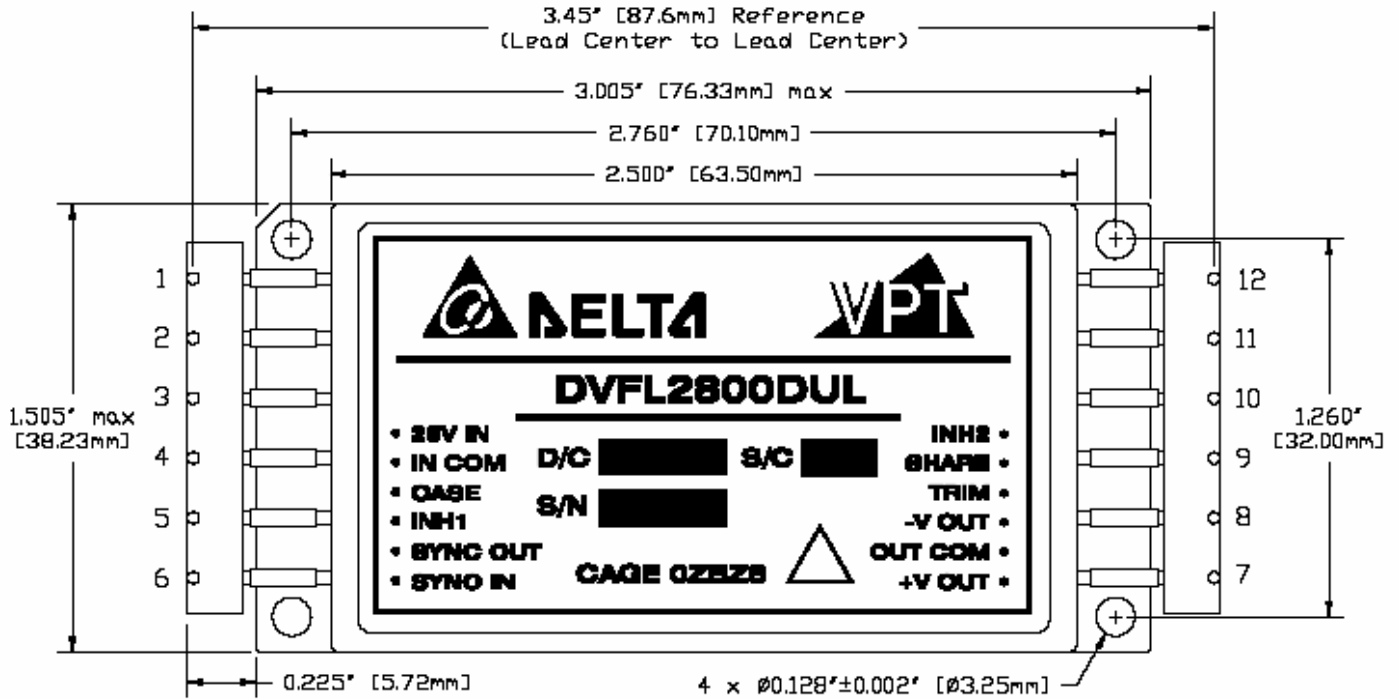

TOP VIEW

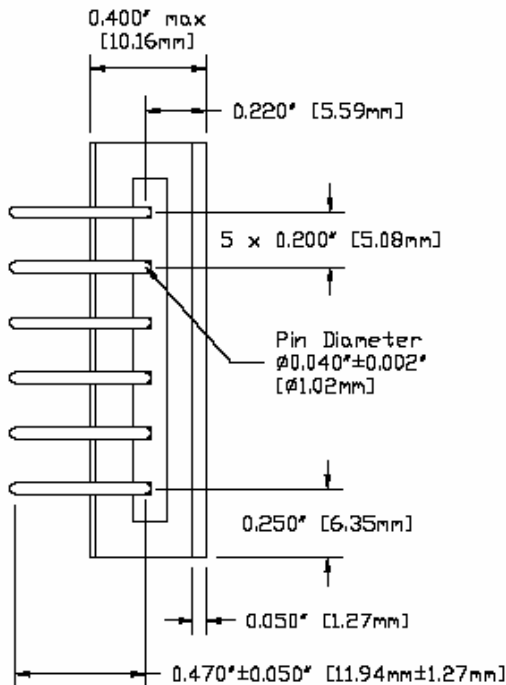

SIDE VIEW

PIN	FUNCTION
1	28V IN
2	IN COM
3	CASE
4	INH1
5	SYNC OUT
6	SYNC IN
7	+V OUT
8	OUT COM
9	-V OUT
10	TRIM
11	SHARE
12	INH2

Figure 16 – Package and Pinout (With Up-Leaded Pin Extensions Added)
(Pin Length is ±0.01", Other Dimensional Limits are ±0.005" Unless Otherwise Stated)

PACKAGE PIN DESCRIPTION

Pin	Function	Description
1	28V IN	Positive Input Voltage Connection
2	IN COM	Input Common Connection
3	CASE	Case Connection
4	INH1	Logic Low = Disabled Output. Connecting the inhibit(1) pin to input common causes converter shutdown. Logic High = Enabled Output. Unconnected or open collector TTL.
5	SYNC OUT	Output Synchronization Signal
6	SYNC IN	Input Synchronization Signal
7	+V OUT	Positive Output Voltage Connection
8	OUT COM	Output Common Connection
9	-V OUT	Negative Output Voltage Connection
10	TRIM	Trim Output Voltage to +10%, -20% of Nominal Value
11	SHARE	Current Share
12	INH2	Logic Low = Disabled Output. Connecting the inhibit(2) pin to output common causes converter shutdown. Logic High = Enabled Output. Unconnected or open collector TTL.

ENVIRONMENTAL SCREENING (100% Tested Per MIL-STD-883 as referenced to MIL-PRF-38534)

Screening	MIL-STD-883	Standard (No Suffix)	Extended /ES	HB /HB	Class H /H	Class K /K
Non-Destructive Bond Pull	Method 2023	•	•	•	•	•
Internal Visual	Method 2017, 2032 Internal Procedure	•	•	•	•	•
Temperature Cycling	Method 1010, Condition C Method 1010, -55°C to 125°C		•	•	•	•
Constant Acceleration	Method 2001, 3000g, Y1 Direction Method 2001, 500g, Y1 Direction		•	•	•	•
PIND	Method 2020, Condition A ²					•
Pre Burn-In Electrical	100% at 25°C					•
Burn-In	Method 1015, 320 hours at +125°C Method 1015, 160 hours at +125°C 96 hours at +125°C 24 hours at +125°C	•	•	•	•	•
Final Electrical	MIL-PRF-38534, Group A ¹ 100% at 25°C	•	•	•	•	•
Hermeticity	Method 1014, Fine Leak, Condition A Method 1014, Gross Leak, Condition C Dip (1 x 10 ⁻³)	•	•	•	•	•
Radiography	Method 2012 ³					•
External Visual	Method 2009	•	•	•	•	•

- Notes:
1. 100% R&R testing at -55°C, +25°C, and +125°C with all test data included in product shipment.
 2. PIND test Certificate of Compliance included in product shipment.
 3. Radiographic test Certificate of Compliance and film(s) included in product shipment.

ORDERING INFORMATION

DVFL	28	05	D	R	DL	/HB	-	XXX
1	2	3	4	5	6	7		8

(1)

(2)

(3)

(4)

Product Series	Nominal Input Voltage		Output Voltage		Number of Outputs	
DVFL	28	28 Volts	05 12 15	±5 Volts ±12 Volts ±15 Volts	D	Dual

(5)

(6)

(7)

(8)

Rad-Hard Option ²		Package Option		Screening Code ^{1,3}		Additional Screening Code
None R	Standard 100 kRad	None DL UL	Standard Down-Lead Up-Lead	None /ES /HB /H /K	Standard Extended HB Class H Class K	Contact Sales

- Notes:
1. Contact the VPT Inc. Sales Department for availability of Class H (/H) or Class K (/K) qualified products.
 2. VPT Inc. is not currently qualified to a DSCC certified radiation hardness assurance program.
 3. VPT Inc. reserves the right to ship higher screened or SMD products to meet lower screened orders at our sole discretion unless specifically forbidden by customer contract.

Please contact your sales representative or the VPT Inc. Sales Department for more information concerning additional environmental screening and testing, different input voltage, output voltage, power requirement, source inspection, and/or special element evaluation for space or other higher quality applications.

SMD (STANDARD MICROCIRCUIT DRAWING) NUMBERS

Standard Microcircuit Drawing (SMD)	DVFL2800D Series Similar Part Number
*T.B.D.	DVFL2805D/H
*T.B.D.	DVFL2812D/H
*T.B.D.	DVFL2815D/H

Do not use the DVFL2800D Series similar part number for SMD product acquisition. It is listed for reference only. For exact specifications for the SMD product, refer to the SMD drawing. SMD's can be downloaded from the DSCC website at <http://www.dscclia.mil/programs/smcr/>. The SMD number listed above is for MIL-PRF-38534 Class H screening, standard gold plated lead finish, and no RHA (Radiation Hardness Assurance) level. Please reference the SMD for other screening levels, lead finishes, and radiation levels.

CONTACT INFORMATION

To request a quotation or place orders please contact your sales representative or the VPT Inc. Sales Department at:

Phone: (425) 353-3010
Fax: (425) 353-4030
E-mail: vptsales@vpt-inc.com

All information contained in this datasheet is believed to be accurate, however, no responsibility is assumed for possible errors or omissions. The products or specifications contained herein are subject to change without notice.