

Performance parameters

2MX10-029-1508

Type	DT _{max} K	Q _{max} W	I _{max} A	U _{max} V	AC R Ohm	H mm	h mm
2MX10-029-xx							
2MX10-029-1508	90	3.55	3.9	2.3	0.5	4.1	1.5 0.8

Performance data are given for $T_{hot}=300K$ vacuum

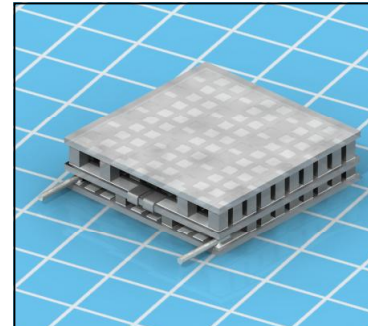

Technical Drawing

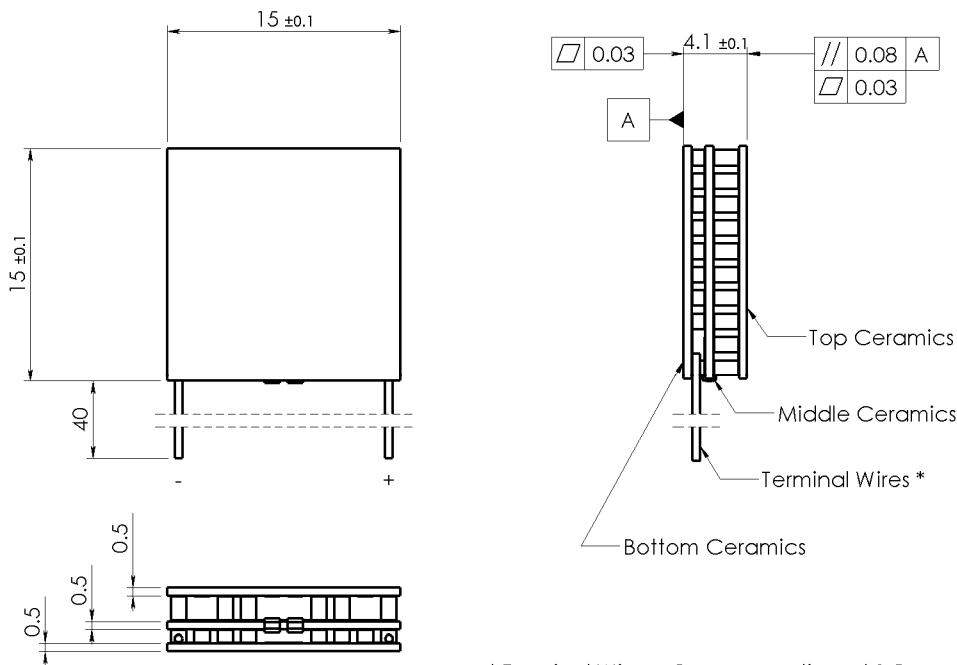

* Terminal Wires - Copper pre-tinned 0.5mm dia

Ordering Options

A. TEC Internal Solder:

Lead-free SnSb Solder ($T_{melt}=230^{\circ}C$)

B. TEC Ceramics:

1. Pure Al_2O_3 (100%)
2. Alumina (Al_2O_3 96%)
3. Aluminium Nitride (AlN)

C. Surface Finish (one or both)

1. Blank Ceramics
2. Metallized:
 - 2.1 Ni-Sn plating
 - 2.2 Au plating
3. Metallized and Pre-tinned
 - 3.1 Solder 94 ($PbSnBi, T_{melt}=94^{\circ}C$)
 - 3.2 Solder 117 ($InSn, T_{melt}=117^{\circ}C$)
 - 3.3 Solder 138 ($SnBi, T_{melt}=138^{\circ}C$)
 - 3.4 Solder 183 ($PbSn, T_{melt}=183^{\circ}C$)
 - 3.5 Solder 199 ($SnZn, T_{melt}=199^{\circ}C$)

D. Thermistor (optional)

NTC thermistor type TB
Resistance nominal
1. 2.2 kOhm@20C
2. 10.0 kOhm@20C

Individual calibration is available in $-65..+85^{\circ}C$

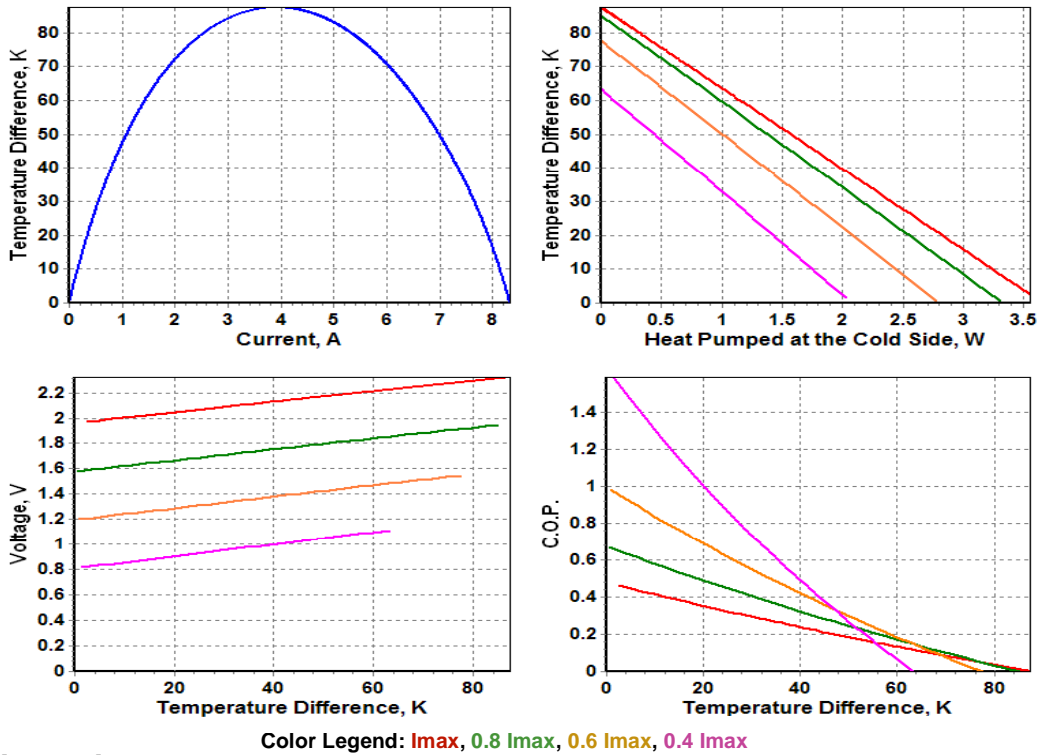

Color Legend: 1.0 A, 0.8 A, 0.6 A, 0.4 A

Applications Tips

Cautions

- Do not heat TE module more than 200°C (TEC assembled at 230°C) or 160°C (optional TECs assembled at 183°C).
- Do not use TE module without attached heat sink at hot (bottom) side.
- Connect TE sub-mount to a DC power supply in accordance to polarity.
- Do not apply DC current higher than I_{max} .

Installation

1. Mechanical Mounting

TEC is placed between two heat exchangers. This construction is fixed by screws or in another mechanical way. It is suitable for large modules (with dimensions 30mmx30mm and larger). Miniature types require other assembling methods.

2. Soldering

This method is suitable for a TE module with metallized outside surfaces (cold and hot sides). RMT provides this option and also makes pre-tinning for TE modules. In comparison with a mechanical assembling method, soldering requires careful procedures.

3. Glueing

A glue is usually based on some epoxy compound filled with some thermoconductive material such as graphite or diamond powders, silver, SiN and others. The application of a specific type depends on application features and the type of a TE module.

Definitions

Value	Description	Notes
ΔT_{max}	Maximum temperature difference at $I=I_{max}$	rated at $Q_{max}=0$, at other Q it should be estimated as $\Delta T = \Delta T_{max}(1 - Q/Q_{max})$
Q_{max}	Maximum heat pumping capacity at $I=I_{max}$	rated at $\Delta T=0$, at other ΔT it should be estimated as $Q = Q_{max}(1 - \Delta T/\Delta T_{max})$
I_{max}	Maximum current	
U_{max}	Maximum voltage drop	Electric parameters resulting in greatest ΔT_{max}
R_t	Header thermal resistance	
-xx	Thermoelectric pellet length code	Pellet length is "-xx" x 10 (in mm)
T_{hot}	TEC hot side temperature	Performance data shown in specifications are given for $T_{hot}=300$ K, vacuum
H	Total TEC height	All dimensions are given in mm