

## DM74ALS373 Octal D-Type TRI-STATE® Transparent Latch

### General Description

These 8-bit registers feature totem-pole TRI-STATE outputs designed specifically for driving highly-capacitive or relatively low-impedance loads. The high-impedance state and increased high-logic-level drive provide these registers with the capability of being connected directly to and driving the bus lines in a bus-organized system without need for interface or pull-up components. They are particularly attractive for implementing buffer registers, I/O ports, bidirectional bus drivers, and working registers.

The eight latches of the ALS373 are transparent D-type latches. While the enable (G) is high the Q outputs will follow the data (D) inputs. When the enable is taken low the output will be latched at the level of the data that was set up.

A buffered output control input can be used to place the eight outputs in either a normal logic state (high or low logic levels) or a high-impedance state. In the high-impedance

state the outputs neither load nor drive the bus lines significantly.

The output control does not affect the internal operation of the latches. That is, the old data can be retained or new data can be entered even while the outputs are off.

### Features

- Switching specifications at 50 pF
- Switching specifications guaranteed over full temperature and  $V_{CC}$  range
- Advanced oxide-isolated, ion-implanted Schottky TTL process
- Functionally and pin for pin compatible with LS TTL counterpart
- Improved AC performance over LS373 at approximately half the power
- TRI-STATE buffer-type outputs drive bus lines directly

### Connection Diagram

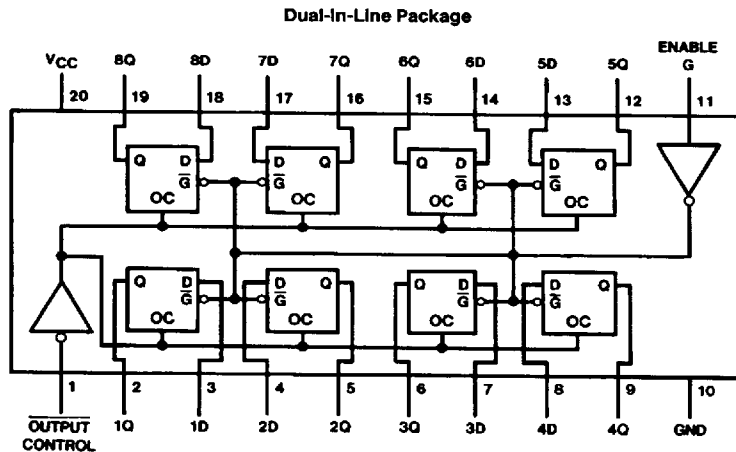

Order Number DM74ALS373WM, DM74ALS373N or DM74ALS373SJ  
See NS Package Number M20B, M20D or N20A

TL/F/6220-1

TRI-STATE® is a registered trademark of National Semiconductor Corporation.

## Absolute Maximum Ratings

Supply Voltage	7V
Input Voltage	7V
Voltage Applied to Disabled Output	5.5V
Operating Free Air Temperature Range DM74ALS	0°C to +70°C
Storage Temperature Range	-65°C to +150°C
Typical $\theta_{JA}$	
N Package	57.0°C/W
M Package	76.0°C/W

Note: The "Absolute Maximum Ratings" are those values beyond which the safety of the device cannot be guaranteed. The device should not be operated at these limits. The parametric values defined in the "Electrical Characteristics" table are not guaranteed at the absolute maximum ratings. The "Recommended Operating Conditions" table will define the conditions for actual device operation.

Note: This product meets application requirements of 500 temperature cycles from -65°C to +150°C.

## Recommended Operating Conditions

Symbol	Parameter	Min	Nom	Max	Units
$V_{CC}$	Supply Voltage	4.5	5	5.5	V
$V_{IH}$	High Level Input Voltage	2			V
$V_{IL}$	Low Level Input Voltage			0.8	V
$I_{OH}$	High Level Output Current			-2.6	mA
$I_{OL}$	Low Level Output Current			24	mA
$t_w$	Width of Enable Pulse, High or Low	10			ns
$t_{SU}$	Data Setup Time	10 ↓			ns
$t_H$	Data Hold Time	7 ↓			ns
$T_A$	Free Air Operating Temperature	0		70	°C

The (↓) arrow indicates the negative edge of the enable is used for reference.

## Electrical Characteristics

over recommended operating free air temperature range. All typical values are measured at  $V_{CC} = 5V$ ,  $T_A = 25^\circ C$ .

Symbol	Parameter	Conditions	Min	Typ	Max	Units
$V_{IK}$	Input Clamp Voltage	$V_{CC} = 4.5V$ , $I_I = -18 mA$			-1.5	V
$V_{OH}$	High Level Output Voltage	$V_{CC} = 4.5V$ $I_{OH} = -2.6 mA$	2.4	3.3		V
		$V_{CC} = 4.5V$ to $5.5V$ $I_{OH} = -400 \mu A$	$V_{CC} - 2$			V
$V_{OL}$	Low Level Output Voltage	$V_{CC} = 4.5V$ $I_{OL} = 24 mA$		0.35	0.5	V
$I_I$	Input Current at Max Input Voltage	$V_{CC} = 5.5V$ , $V_{IH} = 7V$			0.1	mA
$I_{IH}$	High Level Input Current	$V_{CC} = 5.5V$ , $V_{IH} = 2.7V$			20	$\mu A$
$I_{IL}$	Low Level Input Current	$V_{CC} = 5.5V$ , $V_{IL} = 0.4V$			-0.1	mA
$I_O$	Output Drive Current	$V_{CC} = 5.5V$ $V_O = 2.25V$	-30		-112	mA
$I_{OZH}$	Off-State Output Current High Level Voltage Applied	$V_{CC} = 5.5V$ $V_O = 2.7V$			20	$\mu A$
$I_{OZL}$	Off-State Output Current Low Level Voltage Applied	$V_{CC} = 5.5V$ $V_O = 0.4V$			-20	$\mu A$
$I_{CC}$	Supply Current	$V_{CC} = 5.5V$ Outputs Open	Outputs High	9	16	mA
			Outputs Low	16	25	mA
			Outputs Disabled	17	27	mA

## Switching Characteristics over recommended operating free air temperature range (Note 1)

Symbol	Parameter	Conditions	From	To	Min	Max	Units
t <sub>PLH</sub>	Propagation Delay Time Low to High Level Output	V <sub>CC</sub> = 4.5V to 5.5V R <sub>L</sub> = 500Ω C <sub>L</sub> = 50 pF	Data	Any Q	2	12	ns
t <sub>PHL</sub>	Propagation Delay Time High to Low Level Output		Data	Any Q	4	16	ns
t <sub>PLH</sub>	Propagation Delay Time Low to High Level Output		Enable	Any Q	6	22	ns
t <sub>PHL</sub>	Propagation Delay Time High to Low Level Output		Enable	Any Q	7	23	ns
t <sub>PZH</sub>	Output Enable Time to High Level Output		Output Control	Any Q	6	18	ns
t <sub>PZL</sub>	Output Enable Time to Low Level Output		Output Control	Any Q	5	20	ns
t <sub>PHZ</sub>	Output Disable Time from High Level Output		Output Control	Any Q	2	10	ns
t <sub>PLZ</sub>	Output Disable Time from Low Level Output		Output Control	Any Q	2	12	ns

Note 1: See Section 5 for test waveforms and output load.

### Function Table

Output Control	Enable G	D	Output Q
L	H	H	H
L	H	L	L
L	L	X	Q <sub>0</sub>
H	X	X	Z

L = Low State, H = High State, X = Don't Care

Z = High Impedance State

Q<sub>0</sub> = Previous Condition of Q

# Logic Diagram

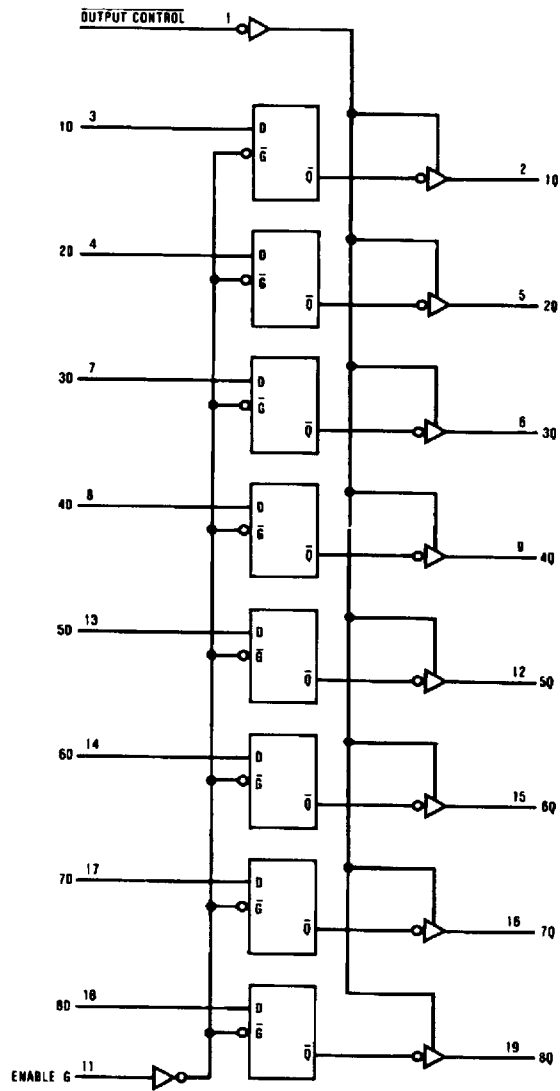

TL/F/6220-2

**Physical Dimensions** inches (millimeters)

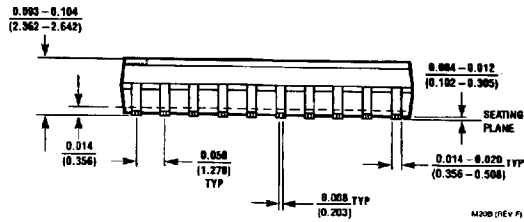
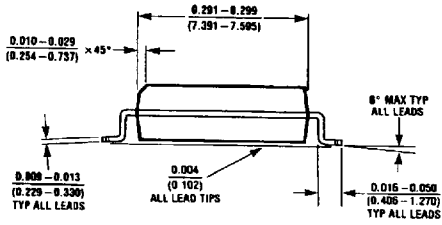
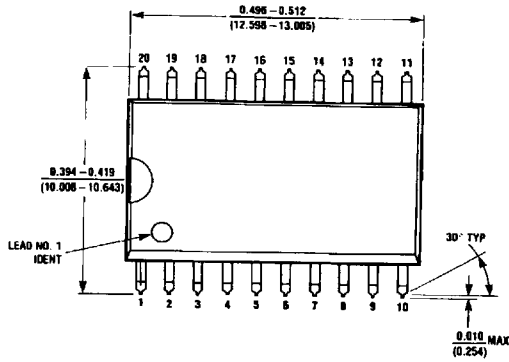

**S.O. Package (M)**  
**Order Number DM74ALS373WM**  
**NS Package Number M20B**

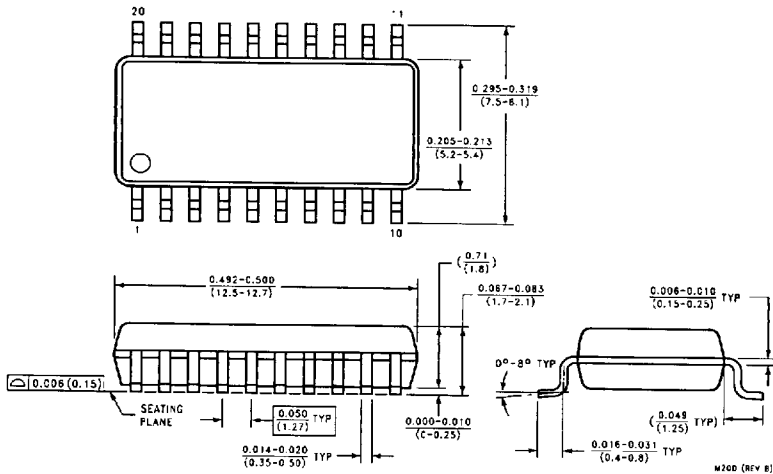

**Small Outline Package (SJ)**  
**Order Number DM74ALS373SJ**  
**NS Package Number M20D**

**Physical Dimensions** inches (millimeters) (Continued)

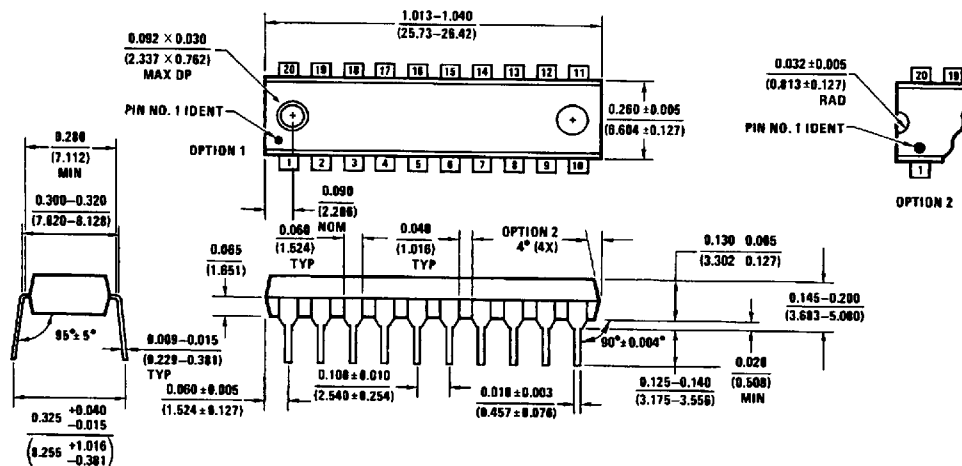

**Molded Dual-In-Line Package (N)**  
**Order Number DM74ALS373N**  
**NS Package Number N20A**

N20A (REV D)

**LIFE SUPPORT POLICY**

NATIONAL'S PRODUCTS ARE NOT AUTHORIZED FOR USE AS CRITICAL COMPONENTS IN LIFE SUPPORT DEVICES OR SYSTEMS WITHOUT THE EXPRESS WRITTEN APPROVAL OF THE PRESIDENT OF NATIONAL SEMICONDUCTOR CORPORATION. As used herein:

1. Life support devices or systems are devices or systems which, (a) are intended for surgical implant into the body, or (b) support or sustain life, and whose failure to perform, when properly used in accordance with instructions for use provided in the labeling, can be reasonably expected to result in a significant injury to the user.
2. A critical component is any component of a life support device or system whose failure to perform can be reasonably expected to cause the failure of the life support device or system, or to affect its safety or effectiveness.

**National Semiconductor Corporation**  
 1111 West Bardin Road  
 Arlington, TX 76017  
 Tel: 1(800) 272-9959  
 Fax: 1(800) 737-7018  
<http://www.national.com>

**National Semiconductor Europe**  
 Fax: +49 (0) 180-530 85 86  
 Email: [europe.support@nsc.com](mailto:europe.support@nsc.com)  
 Deutsch Tel: +49 (0) 180-530 85 85  
 English Tel: +49 (0) 180-532 78 32  
 Français Tel: +49 (0) 180-532 93 58  
 Italiano Tel: +49 (0) 180-534 16 80

**National Semiconductor Hong Kong Ltd.**  
 13th Floor, Straight Block,  
 Ocean Centre, 5 Canton Rd.  
 Tsimshatsui, Kowloon  
 Hong Kong  
 Tel: (852) 2737-1600  
 Fax: (852) 2736-9960

**National Semiconductor Japan Ltd.**  
 Tel: 81-043-299-2308  
 Fax: 81-043-299-2408

National does not assume any responsibility for use of any circuitry described, no circuit patent licenses are implied and National reserves the right at any time without notice to change said circuitry and specifications.