



8-CHANNEL MULTIRATE 1.0–3.2-GBPS RETIMER/SWITCH

FEATURES

- **8 independent retimer channels supporting multiple data rates from 1.0 to 3.2 Gbps, including 1.06 Gbps, 1.25 Gbps, 2.12 Gbps, 2.488 Gbps, 2.5 Gbps, 2.667 Gbps, 3.125 Gbps, and 3.1875 Gbps**
- **Multi-configurable to support various operating modes**
 - Eight independent 1.0 to 3.2 Gbps retiming channels (single clock domain)
 - Dual XAUI to XAUI retiming channels with redundancy compatible to IEEE802.3ae
 - Single XAUI to redundant XAUI retiming switch
 - Full mesh switching mode maps all channels for full redundancy on both transmitter and receiver
- **Low power dissipation**
 - Less than 400 mW per retiming/switch channel including I/O
- **High performance programmable Rx equalization and Tx pre-emphasis**
 - Tx pre-emphasis for interoperability with CML SerDes
 - Rx equalization for copper interconnects
- **Enhanced test capability**
 - Full loopback, BIST, 10G BERT, and random Ethernet packet generation
- **Compact 23-mm × 23-mm package with no external components required**
 - No requirement for heat sink or airflow

SUMMARY OF BENEFITS

- One device supports a variety of applications including Gigabit Ethernet, 1× and 2× Fibre Channel, OC-48 SONET (with/without FEC), Infiniband, 10-Gigabit Ethernet, 10-Gigabit Fibre Channel, or others.
- Flexible architecture supports programmable configurations enabling an aggregate usable data rate of over 40 Mbps. Built-in redundancy mode provides high availability to support critical line side or backplane applications. The high-speed to high-speed retimer mode extends the use of longer traces on line-card designs.
- Advanced 0.13- μ CMOS process technology provides unparalleled performance while achieving the lowest possible power consumption.
- Eases linecard designs to allow for multiple connectors or low-cost PCB materials such as FR4.
- Drive PMD devices or backplane directly with no external clean-up circuit required.
- Simplifies manufacturability with integrated Built-In Self-Test (BIST), full loopbacks, and programmable PRBS generator/checker.
- Decreases complexity and reduces board space on multichannel linecard designs.

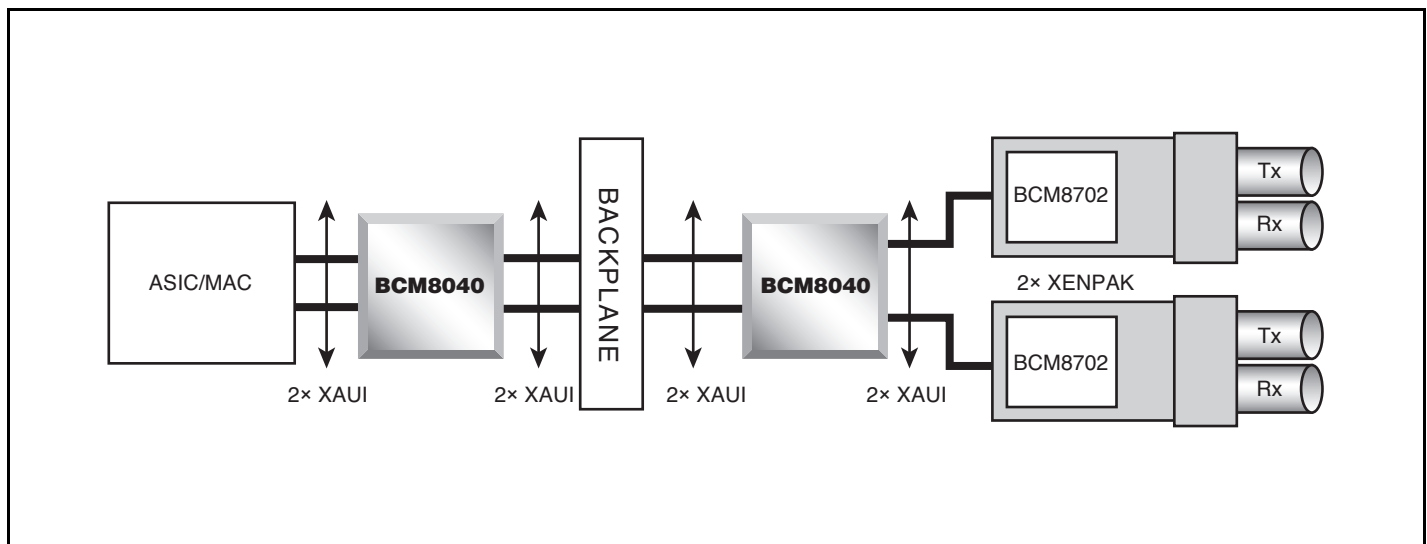

Dual Independent XAUI Cross-Link Application Diagram

OVERVIEW

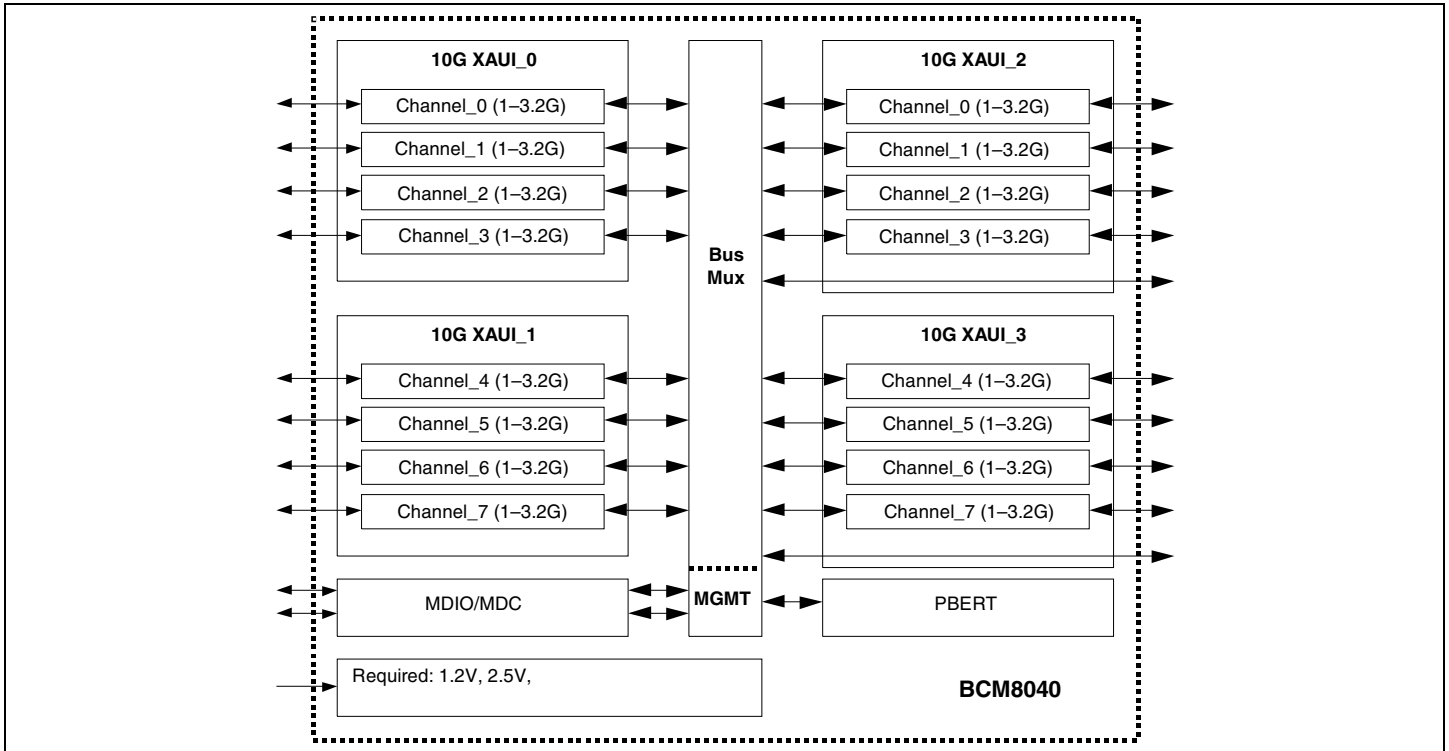

The BCM8040 device integrates 4 independent XGXS (XGMII eXtender Sublayer) cores leveraging Broadcom's high-performance mixed-signal design experience along with advanced 0.13- μ CMOS process technology. Combine this with a robust architecture offering the highest degree of flexibility and the result is a highly programmable, lowest power retimer solution for network line card and backplane applications.

An internal switch connects each serial channel to enable fully redundant operation. The switch fabric enables an active serial link to be switched to the primary channel, while a protection serial link can be continuously monitored to insure its condition. In the event of a failure on the active link, the protection link can be instantly switched over through external control to ensure continued system operation.

Each transmitter and receiver interface supports serial transmissions rates ranging from 1 Gbps to 3.2 Gbps. An on-chip phase lock loop (PLL) synthesizes the supplied reference clock to support the desired transmit rate, while clock and data recovery (CDR) units recover the receive rate clock for timing. The interface can support single-channel (octal) or dual-channel quad (XAUI) differential CML I/O.

Broadcom[®], the pulse logo, and **Connecting everything**[®] are trademarks of Broadcom Corporation and/or its subsidiaries in the United States and certain other countries. All other trademarks mentioned are the property of their respective owners.

Connecting
everything[®]

BROADCOM CORPORATION
16215 Alton Parkway, P.O. Box 57013
Irvine, California 92619-7013

© 2004 by BROADCOM CORPORATION. All rights reserved.

8040-PB04-R 04/15/04

For high-speed serial copper connections, the device incorporates both Tx pre-emphasis on the transmit channels and Rx equalization on the receive channels. Transmit pre-emphasis is programmable to improve the overall cable reach and compensate for electrical imperfections associated with traces and connectors. Rx equalization provides optimal performance over a variety of receive interfaces.

Highly programmable test capabilities within the device support loopbacks using generators/checkers that provide PRBS 27 to 231 patterns along with IEEE802.3ae defined test patterns.

A complete evaluation kit, including an evaluation board, related software, and documentation is available upon request.

Applications

- 1-Gigabit Ethernet and 10-Gigabit Ethernet LAN, MAN, WAN switches and routers
- 1x, 2x, or 10-Gigabit Fibre Channel, Infiniband, SONET Network Cards
- 40-Gbps backplanes and backplane extenders
- Advanced Test Equipment (ATE)



Phone: 949-450-8700
Fax: 949-450-8710
E-mail: info@broadcom.com
Web: www.broadcom.com