

DESCRIPTION

The LXMG1626-05-46 is a Dual 6W Output Direct Drive CCFL (Cold Cathode Fluorescent Lamp) Inverter Module specifically designed to be compatible with variety of LCD panels that have both lamps on one side of the panel and use a single common lamp return wire.

LXMG1626 modules provide the designer with a superior display brightness range. This brightness range is achievable with virtually any LCD display.

The modules are available with a dimming input that permits brightness control from either, a DC voltage source, a PWM signal or external potentiometer.

The maximum output current is externally programmable (through the input connector) at either 10mA or 12mA (5mA or 6mA per lamp). This allows the inverter to match the panel's lamp current specifications, or it can be used to purposely drive the lamps at a lower or higher current to decrease or increase nominal brightness. The inverter also has a dedicated FAULT pin that indicates an open/shorted lamp condition.

In addition when only one of the two lamps in the LCD fails open, the second lamp will continue to operate with a FAULT signal toggling to indicate the failed condition, StayLit™ feature.

RangeMAX Digital Dimming Technique provides flicker-free brightness control in any wide range typically (100:1+) dimming application.

The resultant "burst drive" that energizes the lamp is designed specifically to ensure that no premature lamp degradation occurs, while allowing significant power savings at lower dim levels.

The design utilizes Microsemi's highly integrated LX1691B backlight controller to convert DC voltage from the system battery or AC adapter directly to high frequency, high-voltage waves required to ignite and operate CCFL lamps.

Other benefits of this new topology are stable fixed-frequency operation, secondary-side strike-voltage regulation and both open/shorted lamp protection with fault timeout.

KEY FEATURES

- Externally Programmable Maximum Output Current
- Easy to Use Brightness Control
- RangeMAX Wide Range Dimming
- Output Open & Short-Circuit Protection and Automatic Strike-Voltage Regulation and Timeout
- StayLit™ Continued Operation with Single Open Lamp Failure
- Fixed Frequency Operation
- Fault Output Signal
- Rated From -30 to 80°C
- RoHS Compliant
- UL60950 E175910

APPLICATIONS

- Dual Lamp LCD's Requiring a Shared Common Lamp Return
- Mates to a Single JST BHR-04VS-1 Lamp Connector
- Industrial Display Controls

BENEFITS

- Smooth, Flicker Free 1%-100% Full-Range Brightness Control
- Programmable Output Current Allows Inverter to Mate with a Wide Variety of LCD Panel's Specifications
- Output Open Circuit Voltage Regulation Minimizes Corona Discharge For High Reliability

IMPORTANT: For the most current data, consult MICROSEMI's website: <http://www.microsemi.com>

Protected By U.S. Patents: 5,923,129; 5,930,121; 6,198,234; Patents Pending

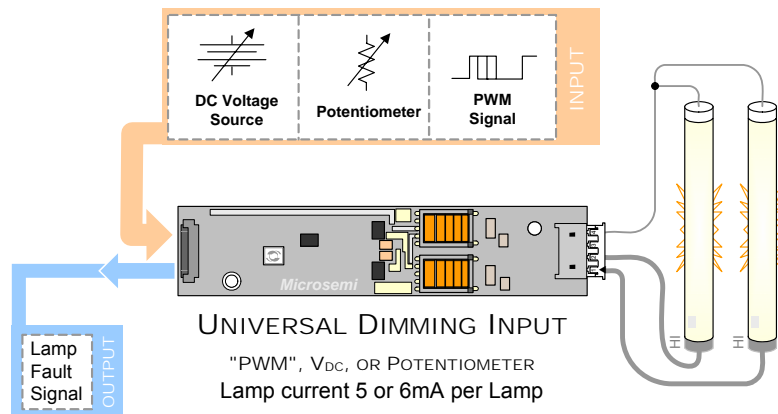
PRODUCT HIGHLIGHT

PACKAGE ORDER INFO

PART NUMBER	OUTPUT CONNECTOR	INVERTER MATES DIRECTLY TO PANEL CONNECTORS
LXMG1626-05-46	JST SM04(4.0)B-BHS-1-TB(LF)(SN) or Yeon Ho 20015WR-07A00 or equivalent	JST BHR-04VS-1

ABSOLUTE MAXIMUM RATINGS

Input Signal Voltage (V_{IN})	-0.3V to 6V
Input Power	8W
Output Voltage, no load	Internally Limited to 1500V _{RMS}
Output Current (per lamp)	6.6mA _{RMS} (Internally Limited)
Output Power	6W
Input Signal Voltage (\overline{SLEEP} Input)	-0.3V to 5.5V
Input Signal Voltage (BRITE)	-0.3V to 5.5V
Ambient Operating Temperature, zero airflow	-30°C to 80°C
Operating Relative Humidity, non-condensing	≤90%
Storage Temperature Range	-40°C to 85°C

Exceeding these ratings could cause damage to the device. All voltages are with respect to Ground. Currents are positive into, negative out of specified terminal.

RECOMMENDED OPERATING CONDITIONS (R.C.)

This module has been designed to operate over a wide range of input and output conditions. However, best efficiency and performance will be obtained if the module is operated under the condition listed in the 'R.C.' column. Min. and Max. columns indicate values beyond which the inverter, although operational, will not function optimally.

Parameter	Symbol	Recommended Operating Conditions			Units
		Min	R.C.	Max	
Input Supply Voltage Range (Fully Regulated Lamp Current)	V_{IN}	4.75	5	5.25	V
Input Supply Voltage Range (Functional)		4.5	5	5.5	
Output Power	P_O		4.5	5.5	W
Linear BRITE Control Input Voltage Range	V_{BRT_ADJ}	0		2.0	V
Lamp Operating Voltage	V_{LAMP}	320	370	420	V _{RMS} ¹
Lamp Current (Full Brightness, per lamp)	I_{OLAMP}	5.0		6.0	mA _{RMS} ²
Operating Ambient Temperature Range	T_A	-30		80	°C

¹ Based on single lamp voltage measurement, use of lamps outside of this range may result in false triggering of the fault detection circuitry.

² At input voltages below 5V the inverter may not be able to output the full 6mA_{RMS} per lamp in all configurations.

ELECTRICAL CHARACTERISTICS

Unless otherwise specified, the following specifications apply over the recommended operating condition and ambient temperature of 0°C to 60°C except where otherwise noted.

Parameter	Symbol	Test Conditions	LXMG1626-05-46			Units
			Min	Typ	Max	
OUTPUT PIN CHARACTERISTICS						
Full Bright Lamp Current (two lamps)	$I_{L(MAX)}$	$V_{BRT_ADJ} \geq 2.0V$, $\overline{SLEEP} \geq 2.0V$, $V_{IN} = 5V$ $I_{SET} = \text{Ground}$	9	10	11	mA _{RMS}
Full Bright Lamp Current (two lamps)	$I_{L(MAX)}$	$V_{BRT_ADJ} \geq 2.0V$, $\overline{SLEEP} \geq 2.0V$, $V_{IN} = 5V$ $I_{SET} = \text{Open}$	11	12	13	mA _{RMS}
Output Current Lamp to Lamp Deviation	$I_{LL\%DEV}$	$V_{BRT_ADJ} \geq 2.0V$, $\overline{SLEEP} \geq 2.0V$, $V_{IN} = 5V$ $I_{SET} = \text{Open}$		5		%
Min. Average Lamp Current	$I_{L(MIN)}$	$V_{BRT_ADJ} = 0V$, $\overline{SLEEP} \geq 2.0V$, $V_{IN} = 5V$ $I_{SET} = \text{Ground}$; $I_{OUT} = I_{MAX} * \text{SQRT of \% duty cycle}$		1.6		mA _{RMS}
Lamp Start Voltage	V_{LS}	$V_{IN} > 4.5V$	1250	1400		V _{RMS}
Operating Frequency	f_O	$V_{BRT_ADJ} = 2.0V$, $\overline{SLEEP} \geq 2.0V$, $V_{IN} = 5V$	55.2	57.6	60	kHz
Burst Frequency	f_{BURST}	Output Burst Frequency	215	225	235	Hz
FAULT Output Voltage High	FAULT _{VH}	FAULT = -10uA	2.9	3.4		V
FAULT Output Voltage Low	FAULT _{VL}	FAULT = 10uA		0.3	0.8	V

ELECTRICAL CHARACTERISTICS (CONTINUED)

Unless otherwise specified, the following specifications apply over the recommended operating condition and ambient temperature of 0°C to 60°C except where otherwise noted.

Parameter	Symbol	Test Conditions	LXMG1626-05-46			Units
			Min	Typ	Max	
▶ BRITE INPUT						
Input Current	I_{BRT}	$V_{BRT_ADJ} = 0V$		-13		μA_{DC}
		$V_{BRT_ADJ} = 3V$		1		μA_{DC}
Minimum Input for Max. Lamp Current	V_{BRT_ADJ}	$I_{O(LAMP)} = \text{Maximum Lamp Current}$		1.9	2.0	V
Maximum Input for Min. Lamp Current	V_{BRT_ADJ}	$I_{O(LAMP)} = \text{Minimum Lamp Current}$	0			V
▶ SLEEP BAR INPUT						
RUN Mode	V_{SLEEP}		2.1		V_{IN}	V
SLEEP Mode	V_{SLEEP}		-0.3		0.8	V
▶ SET INPUT						
SET Low Threshold	V_L				0.4	V
Input Current	I_{SET}	$V_{SET} \leq 0.4V$		-420		μA
▶ POWER CHARACTERISTICS						
Sleep Current	$I_{IN(MIN)}$	$V_{IN} = 5V, \overline{SLEEP} \leq 0.8V$	0.0	12	50	μA_{DC}
Run Current	$I_{IN(RUN)}$	$V_{IN} = 5V, \overline{SLEEP} \geq 2.0V, I_{SET} = \text{Ground}$ $V_{LAMP} = 370V_{RMS}$		870		mA_{DC}
Efficiency	η	$V_{IN} = 5V, \overline{SLEEP} \geq 2.0V, I_{SET} = \text{Ground}$ $V_{LAMP} = 370V_{RMS}$		85		%

FUNCTIONAL PIN DESCRIPTION

CONN	PIN	DESCRIPTION
CN1 (Molex 53261-0871 or equivalent) Mates with 51021-0800 housing, 50079-8100 pins. Mates with LX9501G input cable assembly		
CN1-1	V_{IN}	Main Input Power Supply ($4.75V \leq V_{IN} \leq 5.25V$)
CN1-2		
CN1-3	GND	Power Supply Return
CN1-4		
CN1-5	\overline{SLEEP}	ON/OFF Control. ($0V < \overline{SLEEP} \leq 0.8 = \text{OFF}, \overline{SLEEP} \geq 2.1V = \text{ON}$)
CN1-6	BRITE	Brightness Control (0V to 2.0V). 2.0V gives maximum lamp current.
CN1-7	SET	Connecting this pin to ground decreases the output current (see Table 1)
CN1-8	FAULT	High Impedance Output that indicates lamp status, high indicates fault (see figure 2 on page 5)
CN2 for LXMG1626-05-46 (JST SM03(4.0)B-BHS-1-TB(LF)(SN) or Yeon Ho 20015WR-07A00 or equivalent)		
CN2-1	V_{HI1}	High voltage connection to high side of lamp. Connect to lamp terminal with shortest lead length. DO NOT connect to ground.
CN2-2	V_{HI2}	High voltage connection to high side of lamp. Connect to lamp terminal with shortest lead length. DO NOT connect to ground.
CN2-3	NC	No Connect
CN2-4	V_{LO}	Connection to low side of lamp. Connect to lamp terminal with longer lead length. DO NOT connect to ground

TABLE 1
OUTPUT CURRENT SETTINGS

SET ₁ (Pin 7)	Nominal Output Current
Open*	12mA
Ground	10mA

* If driven by a logic signal it should be open collector or open drain only, not a voltage source.

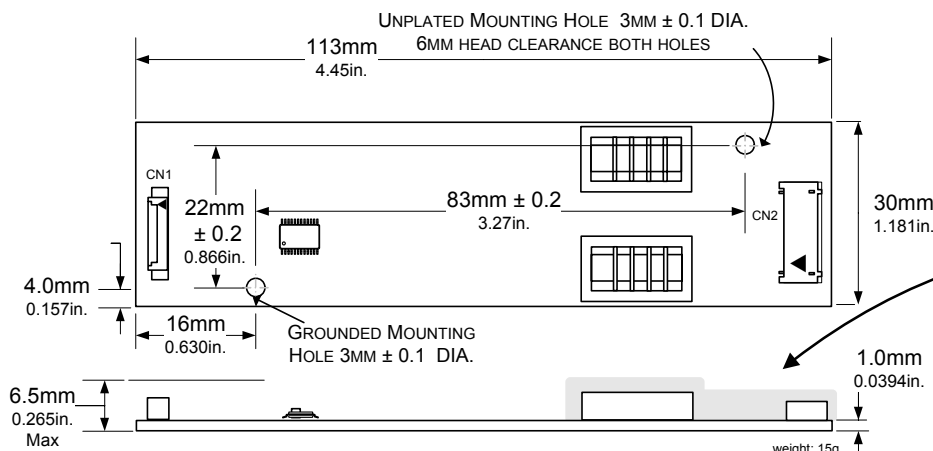
PHYSICAL DIMENSIONS
LXMG1626-05-46

Warning
High Voltage is present at high side of transformers, their cores and the high side of the output connector, when mounting please provide at least 2 mm clearance (in all directions) on the component side of the board to any conductor

Outside PCB tolerances $\pm 0.5\text{mm}$, 4-40 recommended mounting screws

All dimensions are in millimeters, inches are for reference only

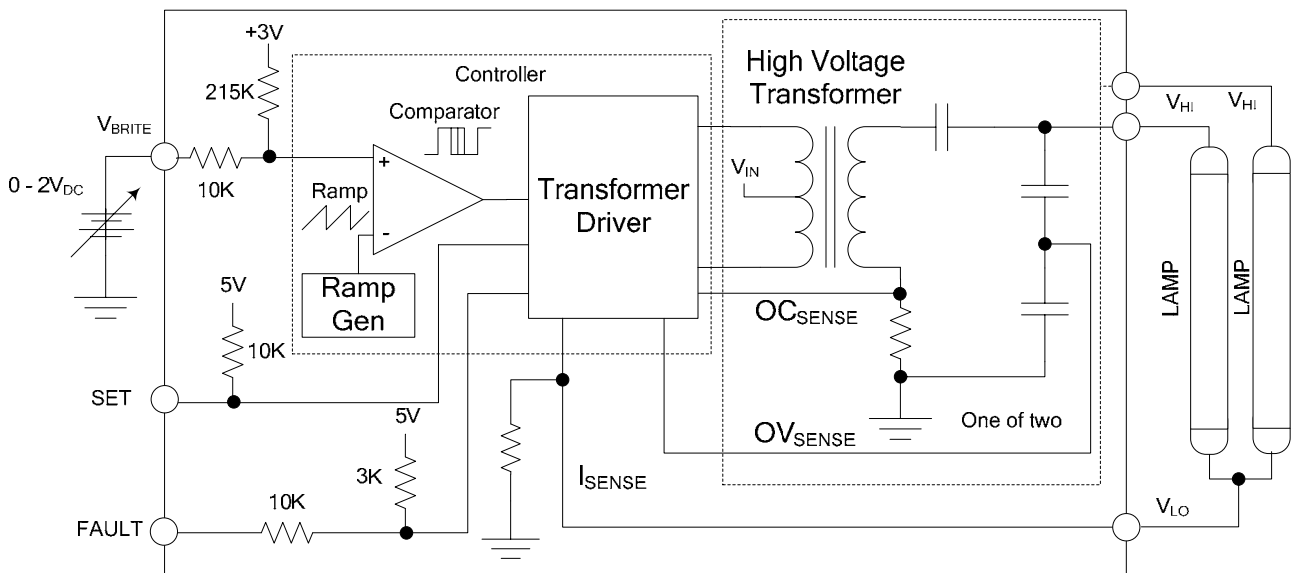
SIMPLIFIED BLOCK DIAGRAM

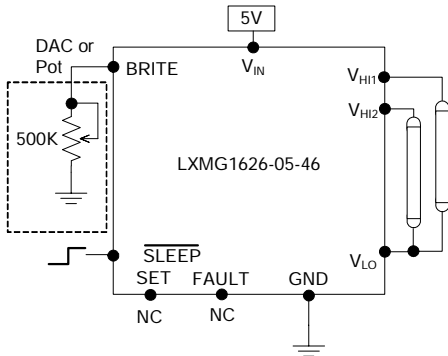
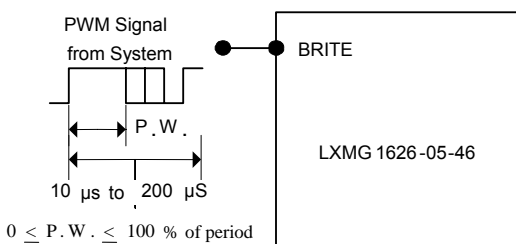
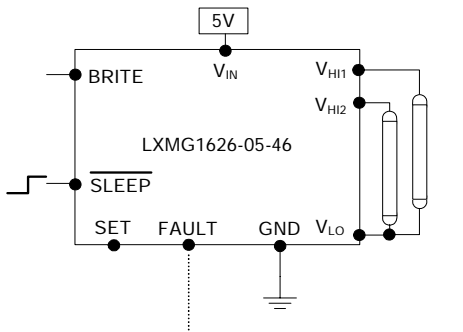
TYPICAL APPLICATION

Figure 1 – Brightness Control
 (Output current set to maximum)

Figure 1A – PWM Brightness Control

Figure 2 – FAULT Output Operation

Lamp(s) Status	FAULT	Inverter Operation
Normal Operation	Low	Normal full lamp current
One Lamp Open	High	Normal @ ~½ lamp current*
Both Lamps Open	High	Shutdown
One Lamp High Side Short to Ground	High	Normal @ ~½ lamp current*
Both Lamps High Side Short to Ground	High	Shutdown

* Under some conditions the second lamp will also shutdown, this is especially true if the inverter draws an arc going open or when shorted.

- The brightness control may be a voltage output DAC or other voltage source, a digital pot or 500k manual pot. The inverter contains an internal 215k pull-up to 3V to bias the pot. A 3.3V Logic Level PWM signal from a micro-controller may also be used as shown in Figure 1A.
- If you need to turn the inverter ON/OFF remotely, connect to TTL logic signal to the SLEEP input.
- Connect V_{HI1} and V_{HI2} to high voltage wires from the lamps. Connect V_{LO} to the low voltage lamp return wire (wire with thinner insulation). Never connect V_{LO} to circuit ground as this will defeat lamp current regulation.
- Use the SET input to program the desired maximum output current. Generally the best lamp lifetime correlates with driving the CCFL at the manufacturer's nominal current setting.
- Typically the SET pin is permanently wired to ground or intentionally left open. However it can also be actively driven, using an open collector or open drain logic signal. This will allow dynamic adjustment of the lamp current for situations where greater dim range is required, as an example in nighttime situations. In conjunction with a light sensor or other timer, the panel could be set to higher brightness (maximum output current) for daytime illumination and lower brightness (minimum or typical output current) at nighttime. Since the dimming ratio is a factor of both the burst duty cycle and the peak output current, by using this technique the effective dim ratio can be increased greater than what the burst duty cycle alone could provide. Conversely, the SET input could be used to overdrive the lamp current temporarily. Of course, any possible degradation of lamp life from such practices is the user's responsibility since not all lamps are designed to be under or overdriven.
- Input connector (CN1-8) FAULT signal which is normally low will toggle high to indicate that an output fault condition has occurred as summarized in the table to the left figure 2. FAULT will toggle high if one or both lamps are open or short circuited. If only one lamp opens, or its high side shorts to ground then the other lamp should continue to operate with the FAULT signal going high. If both lamps open and/or both lamps are shorted the FAULT will toggle high if it is not already high and the inverter output will shutdown. Also if either low side connection of the lamps is shorted to ground, or the lamps are shorted high side to low side, FAULT will go high and the inverter will shutdown. In order to restart the inverter after a fault it is necessary to toggle the SLEEP input or cycle the V_{IN} input supply. In fault induced shutdown mode the inverter will draw about 15mA from V_{IN} supply.



PanelMatch™ StayLit™

LXMG1626-05-46

5V Dual 6W CCFL Programmable Inverter Module

PRODUCTION DATASHEET

NOTES

PRODUCTION DATA – Information contained in this document is proprietary to Microsemi and is current as of publication date. This document may not be modified in any way without the express written consent of Microsemi. Product processing does not necessarily include testing of all parameters. Microsemi reserves the right to change the configuration and performance of the product and to discontinue product at any time