

General Description

The AAT3683 BatteryManager is a highly integrated single-cell lithium-ion / polymer (Li-Ion) battery charger that operates from a USB port or an AC adapter input up to an input voltage of 6.5V.

The AAT3683 precisely regulates battery charge voltage and current for 4.2V Li-Ion battery cells. The battery charging current can be set by an external resistor up to 1A.

Digital Thermal Loop Control maintains the maximum possible battery charging current for the given set of input to output power dissipation and ambient temperature conditions.

Battery charge state is continuously monitored for fault conditions. In the event of an over-current, over-voltage, short-circuit, or over-temperature condition, the device will shut down automatically, thus protecting the charging device, control system, and the battery under charge. A status monitor output pin is provided to indicate the battery charge status by directly driving an external LED. An open-drain power source detection output is provided to report the power supply status.

The AAT3683 is available in the Pb-free, thermally-enhanced, space-saving 2.2x2.2mm 10-pin STDFN (AAT3683-2 and -3) and 16-pin QFN33 (AAT3683-4) packages and is specified for operation over the -40°C to +85°C temperature range.

Features

- USB or AC Adapter Input
- Programmable from 100mA to 1A
- 4.0V to 6.5V Input Voltage Range
- High Level of Integration with Internal:
 - Charging Device
 - Reverse Blocking Diode
 - Current Sensing
- Digital Thermal Regulation
- Charge Current Programming (ISET)
- Charge Termination Current Programming (TERM)
- Charge Timer (CT)
- Battery Temperature Sensing (TS)
- TS Pin Open Detection
- Automatic Recharge Sequencing
- Automatic Trickle Charge for Battery Pre-Conditioning (no trickle charge option available)
- Full Battery Charge Auto Turn-Off / Sleep Mode / Charge Termination
- 1µA Max. Shutdown Current
- Over-Voltage and Over-Current Protection
- Emergency Thermal Protection
- Power On Reset and Soft Start
- 2.2x2.2mm STDFN-10 (AAT3683-2 and -3) and QFN33-16 (AAT3683-4) Packages

Applications

- Bluetooth Headsets, Headphones, Accessories
- Cellular Phones
- Digital Still Cameras
- MP3, Portable Music, and Portable Media Players
- Personal Data Assistants (PDAs) and Handheld Computers
- Other Li-Ion Battery-Powered Devices

Typical Application

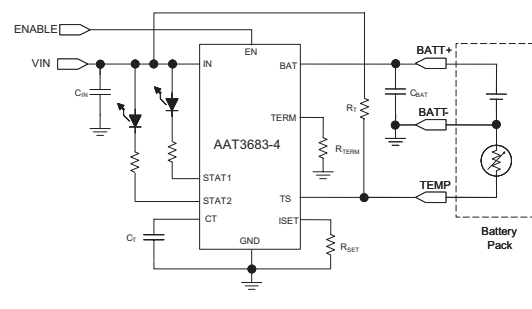
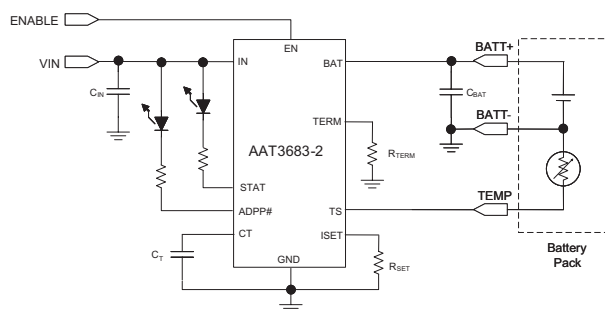

Pin Descriptions

Pin		Name	Type	Function
AAT3683-2, AAT3683-3	AAT3683-4			
1	n/a	STAT	O	Charge status pin, open drain.
n/a	16	STAT1	O	Charge status pin, open drain.
2	2	TERM	I	Charge termination current programming input pin (internal default 10% termination current if TERM is open).
3	3	GND		Ground.
4	4	CT	I	Charge timer programming input pin (no timer if grounded).
5	n/a	ADPP#	O	Input supply power-good status pin, open drain.
n/a	5	STAT2	O	Charge status pin, open drain.
6	7	TS	I/O	Battery temperature sense pin. (Leave this TS pin open to disable this function in AAT3683-2).
7	6	BAT	O	Connect to Li-Ion battery.
8	15	IN	I	Input from USB port/AC adapter connector.
9	11	ISET	I	Charge current programming input pin.
10	12	EN	I	Active high enable pin (with internal pull-down).
n/a	1, 8, 9, 10, 13, 14	N/C		Not connected.
EP	EP			Exposed paddle (bottom); connect to ground as closely as possible to the device.

Pin Configuration

**AAT3683-2,
AAT3683-3
STDFN2.2x2.2-10
(Top View)**

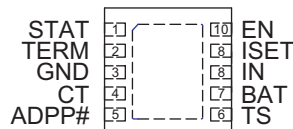

**AAT3683-4
QFN33-16
(Top View)**

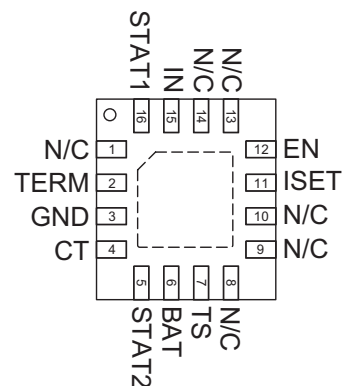

AAT3683 Feature Options

Product	Battery Temperature Sense	Status Indicator Display
AAT3683-2	For Use With 10k Ω NTC Thermistor	1 LED
AAT3683-3	For Use With Any Thermistor	1 LED
AAT3683-4	For Use With Any Thermistor	2 LEDs

Absolute Maximum Ratings¹

Symbol	Description	Value	Units
V_{IN}	IN Continuous	-0.3 to 7.5	V
V_N	BAT, STAT, ADPP#, EN, ISET, TS, STAT1, STAT2	-0.3 to $V_{IN} + 0.3$	V
T_J	Operating Junction Temperature Range	-40 to 150	$^{\circ}\text{C}$
T_{LEAD}	Maximum Soldering Temperature (at Leads)	300	$^{\circ}\text{C}$

Thermal Information²

Symbol	Description		Value	Units
θ_{JA}	Thermal Resistance	STDFN2.2x2.2-10	50	$^{\circ}\text{C}/\text{W}$
		QFN33-16	50	
P_D	Maximum Power Dissipation ($T_A = 25^{\circ}\text{C}$)	STDFN2.2x2.2-10	2	W
		QFN33-16	2	

1. Stresses above those listed in Absolute Maximum Ratings may cause permanent damage to the device. Functional operation at conditions other than the operating conditions specified is not implied. Only one Absolute Maximum Rating should be applied at any one time.
 2. Mounted on an FR4 board.

Electrical Characteristics

$V_{IN} = 5V$, $T_A = -25^\circ C$ to $+85^\circ C$, unless otherwise noted. Typical values are at $T_A = 25^\circ C$.

Symbol	Description	Conditions	Min	Typ	Max	Units
Operation						
V_{IN}	Input Voltage Range		4.0		6.5	V
V_{UVLO}	Under-Voltage Lockout Threshold	Rising Edge	3		4	V
	UVLO Hysteresis			150		mV
V_{ADPP_TH}	Adapter Present Indicator Threshold Voltage, $V_{IN} - V_{BAT}$	$V_{IN} > V_{UVLO}$		60	110	mV
I_{OP}	Operating Current	Charge Current = 100mA		0.3	1	mA
$I_{SHUTDOWN}$	Shutdown Current	$V_{BAT} = 4.25V$, EN = GND		0.4	1	μA
I_{BAT}	Leakage Current from BAT Pin	$V_{BAT} = 4V$, IN Pin Open		0.4	2	μA
Voltage Regulation						
V_{BAT_EOC}	End of Charge Accuracy		4.158	4.20	4.242	V
$\frac{\Delta V_{BAT_EOC}}{V_{BAT_EOC}}$	End of Charge Tolerance			0.5		%
V_{MIN}	Preconditioning Voltage Threshold	(Option available for no trickle charge)	2.5	2.6	2.7	V
V_{RCH}	Battery Recharge Voltage Threshold			$V_{BAT_EOC} - 0.1$		V
Current Regulation						
I_{CC_RANGE}	Charge Current Programmable Range		100		1000	mA
I_{CH_CC}	Constant Current Mode Charge Current	$V_{BAT} = 3.6V$	-12.5		12.5	%
V_{ISET}	ISET Pin Voltage			2		V
K_{ISET}	Charge Current Set Factor: I_{CH_CC}/I_{ISET}	Constant Current Mode, $V_{BAT} = 3.6V$		800		
V_{TERM}	TERM Pin Voltage	$R_{TERM} = 13.3K\Omega$		0.2		V
I_{CH_TRK}	Trickle-Charge Current		5	10	15	% I_{CH_CC}
I_{CH_TERM}	Charge Termination Threshold Current	TERM Pin Open	5	10	15	% I_{CH_CC}
		$R_{TERM} = 13.3K\Omega$, $I_{CH_CC} \geq 800mA$	8	10	12	%

Electrical Characteristics

$V_{IN} = 5V$, $T_A = -25^{\circ}C$ to $+85^{\circ}C$, unless otherwise noted. Typical values are at $T_A = 25^{\circ}C$.

Symbol	Description	Conditions	Min	Typ	Max	Units
Charging Devices						
$R_{DS(ON)}$	Charging Transistor On Resistance	$V_{IN} = 5V$		0.5	0.7	Ω
Logic Control / Protection						
$V_{EN(H)}$	Input High Threshold		1.6			V
$V_{EN(L)}$	Input Low Threshold				0.4	V
V_{STAT}	Output Low Voltage	STAT Pin Sinks 4mA			0.2	V
I_{STAT}	STAT Pin Current Sink Capability				8	mA
$V_{ADDP\#}$	Output Low Voltage	ADPP# Pin Sinks 4mA			0.2	V
$I_{ADDP\#}$	ADDP# Pin Current Sink Capability				8	mA
V_{OVP}	Over-Voltage Protection Threshold			4.4		V
I_{OCP}	Over-Current Protection Threshold			105		$\%I_{CH_CC}$
TK	Trickle Timeout	$C_T = 0.1\mu F$, $V_{IN} = 5V$		25		Minute
TC	Trickle and Constant Current Mode Timeout	$C_T = 0.1\mu F$, $V_{IN} = 5V$		3		Hour
TV	Constant Voltage Mode Timeout	$C_T = 0.1\mu F$, $V_{IN} = 5V$		3		Hour
I_{TS}	Current Source from TS Pin	AAT3683-2 Only	69	75	81	μA
T_{S1}	TS Hot Temperature Fault	Threshold, AAT3683-2 Only	316	331	346	mV
		Hysteresis, AAT3683-2 Only		25		
T_{S2}	TS Cold Temperature Fault	Threshold, AAT3683-2 Only	2.30	2.39	2.48	V
		Hysteresis, AAT3683-2 Only		25		
V_{TS1}	High Temperature Threshold	AAT3683-3, AAT3683-4 Only	29.1	30	30.9	$\%V_{IN}$
V_{TS2}	Low Temperature Threshold	AAT3683-3, AAT3683-4 Only	58.2	60	61.8	$\%V_{IN}$
T_{LOOP_IN}	Thermal Loop Entering Threshold			115		$^{\circ}C$
T_{LOOP_OUT}	Thermal Loop Exiting Threshold			85		$^{\circ}C$
T_{REG}	Thermal Loop Regulation			100		$^{\circ}C$
T_{SHDN}	Over-Temperature Shutdown	Threshold		140		$^{\circ}C$
		Hysteresis		15		

Typical Characteristics

Constant Charging Current vs. Set Resistor Values

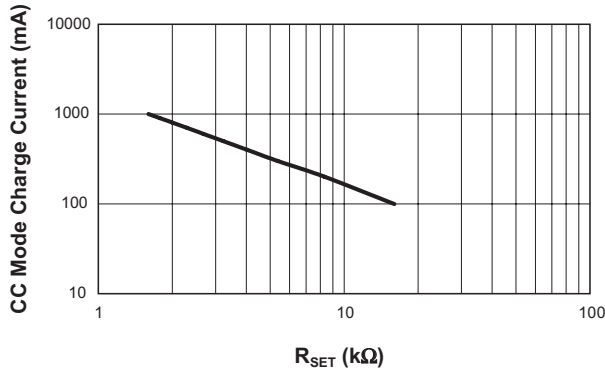

Charging Current vs. Battery Voltage

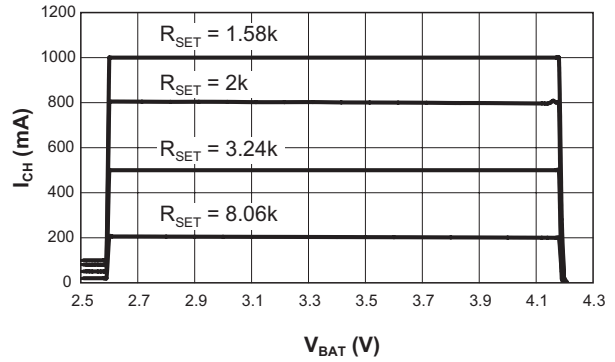

End of Charge Regulation Tolerance vs. Supply Voltage
(V_{BAT_EOC} = 4.2V)

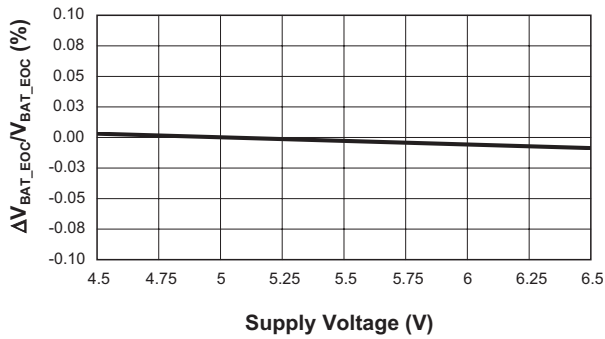

End of Charge Voltage vs. Temperature

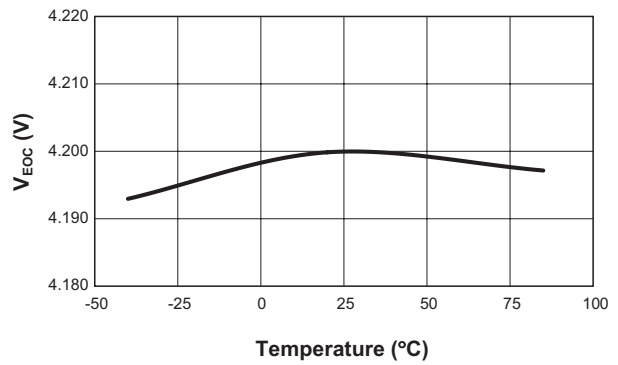

Preconditioning Charge Current vs. Supply Voltage

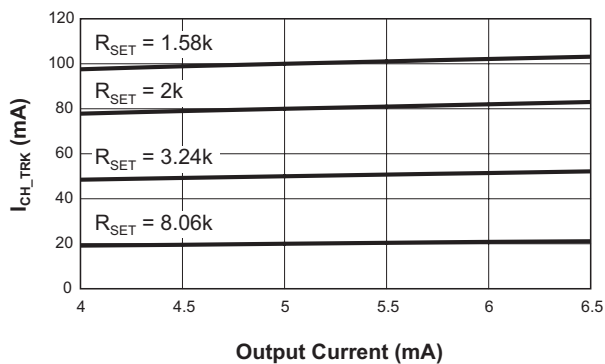

Preconditioning Voltage Threshold vs. Temperature

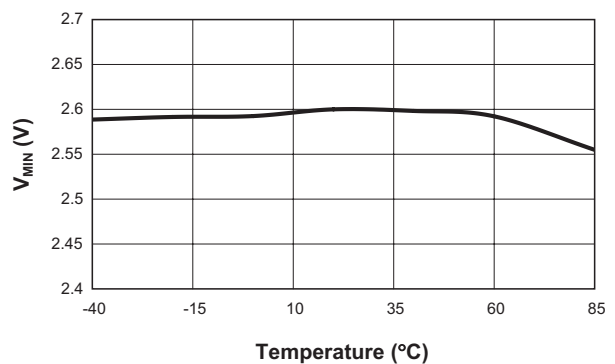

Typical Characteristics

Preconditioning Charge Current vs. Temperature
($R_{SET} = 8.06k$; $I_{CH_CC} = 200mA$)

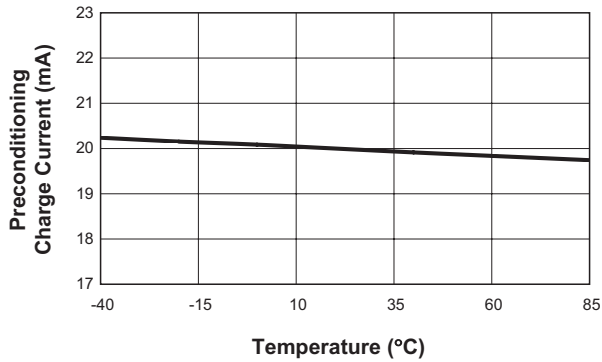

Battery Recharge Voltage Threshold vs. Temperature

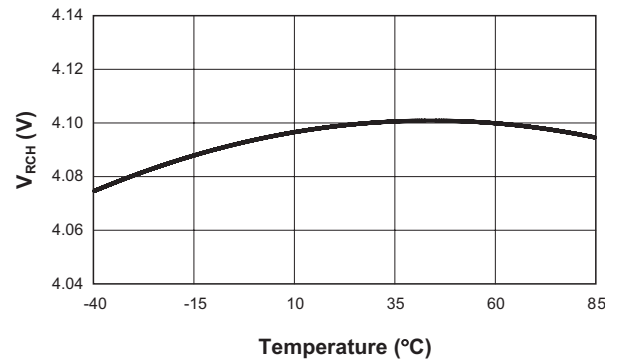

Constant Charging Current vs. Supply Voltage
($R_{SET} = 1.58K\Omega$)

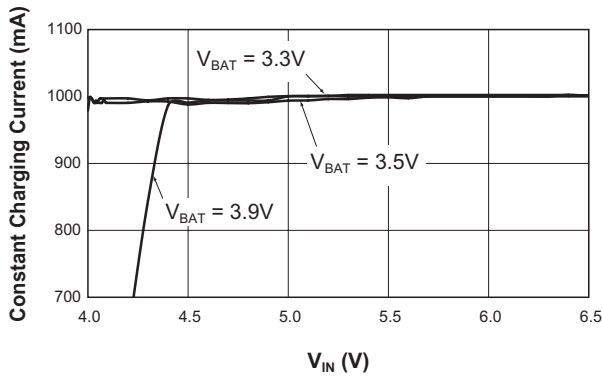

Temperature Sense Output Current vs. Temperature (AAT3683-2 Only)

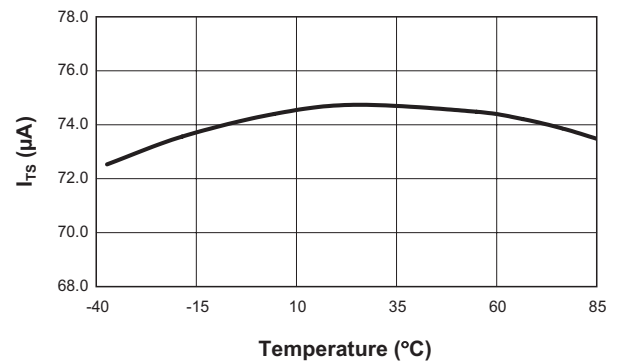

Temperature Sense Too Hot Threshold vs. Temperature (AAT3683-2 Only)

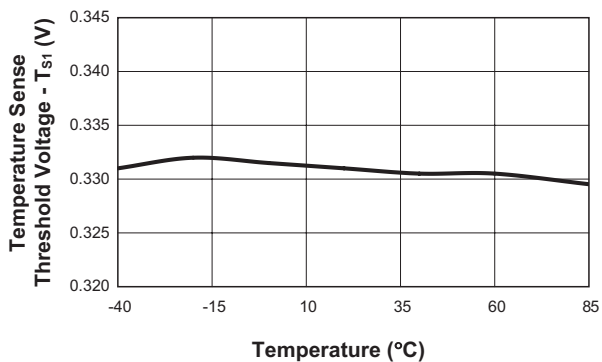

Temperature Sense Too Cold Threshold vs. Temperature (AAT3683-2 Only)

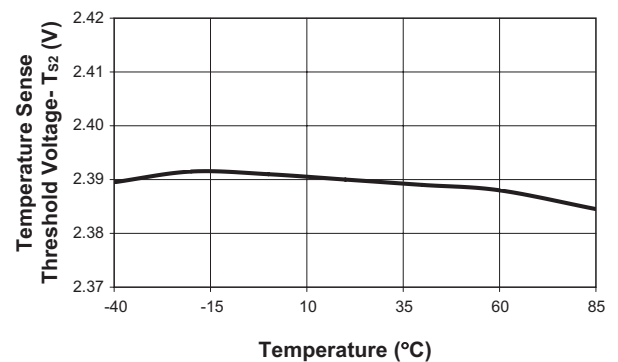

Typical Characteristics

Operating Current vs. I_{SET} Resistor

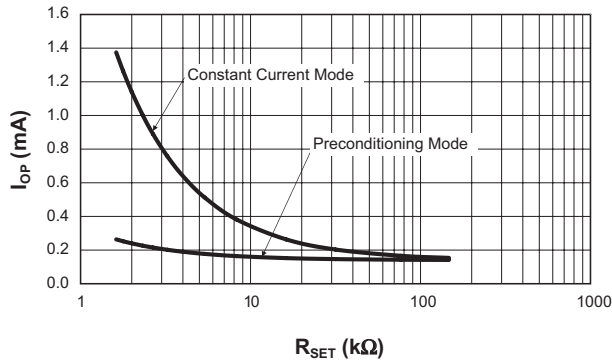

Shutdown Current vs. Supply Voltage

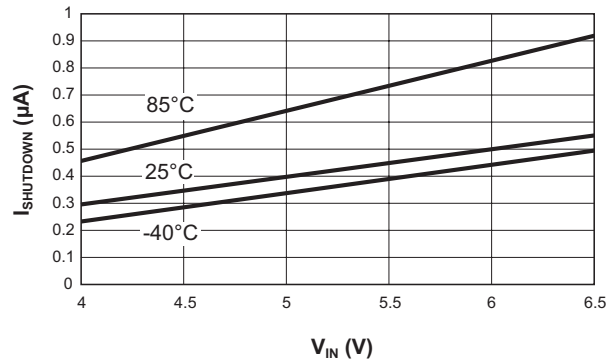

Counter Timeout vs. Temperature
($C_T = 0.1\mu$ F)

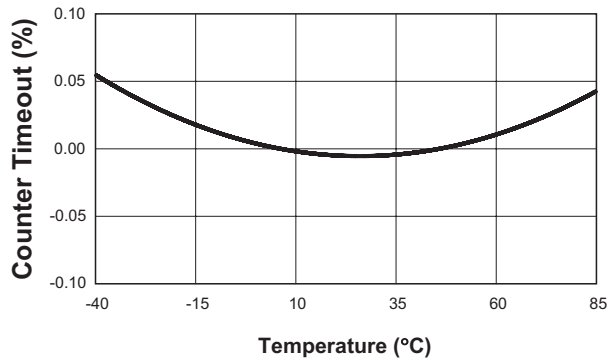

CT Pin Capacitance vs. Counter Timeout

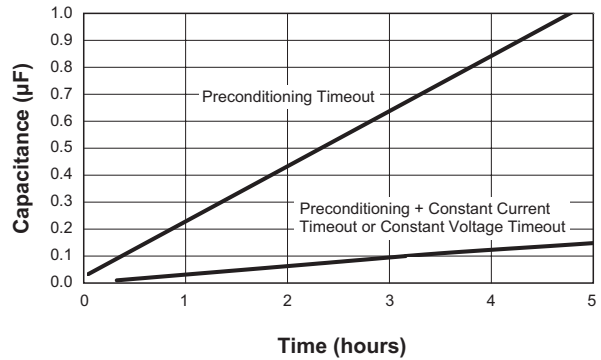

Termination Current to Constant Current Ratio (%)
vs. Termination Resistance

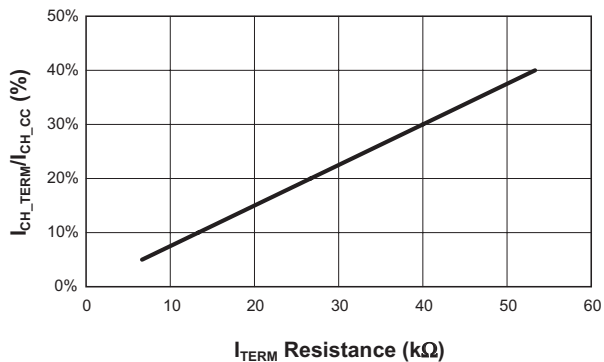

Charging Transistor On Resistance
vs. Supply Voltage

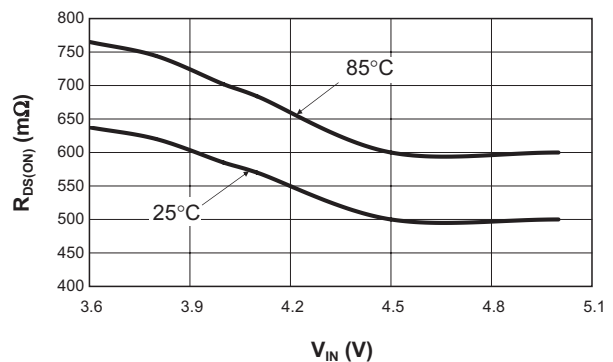

Typical Characteristics

Input High Threshold vs. Supply Voltage

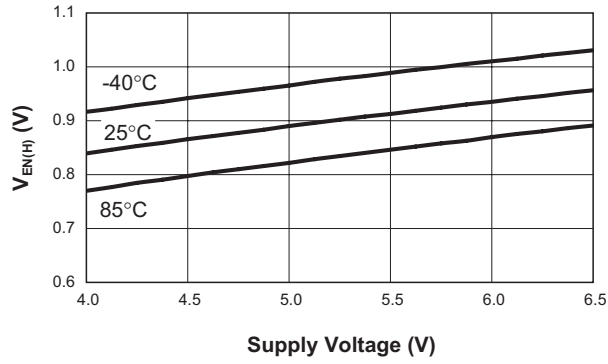

Input Low Threshold vs. Supply Voltage

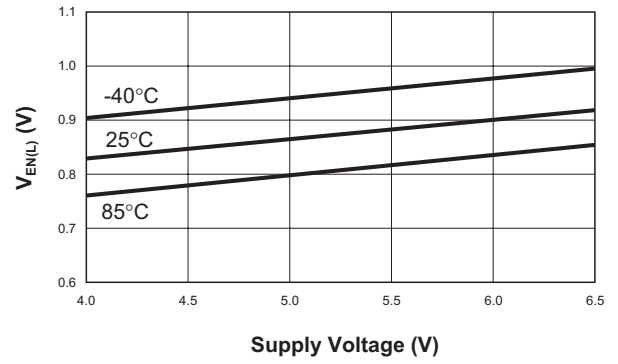

Functional Block Diagram

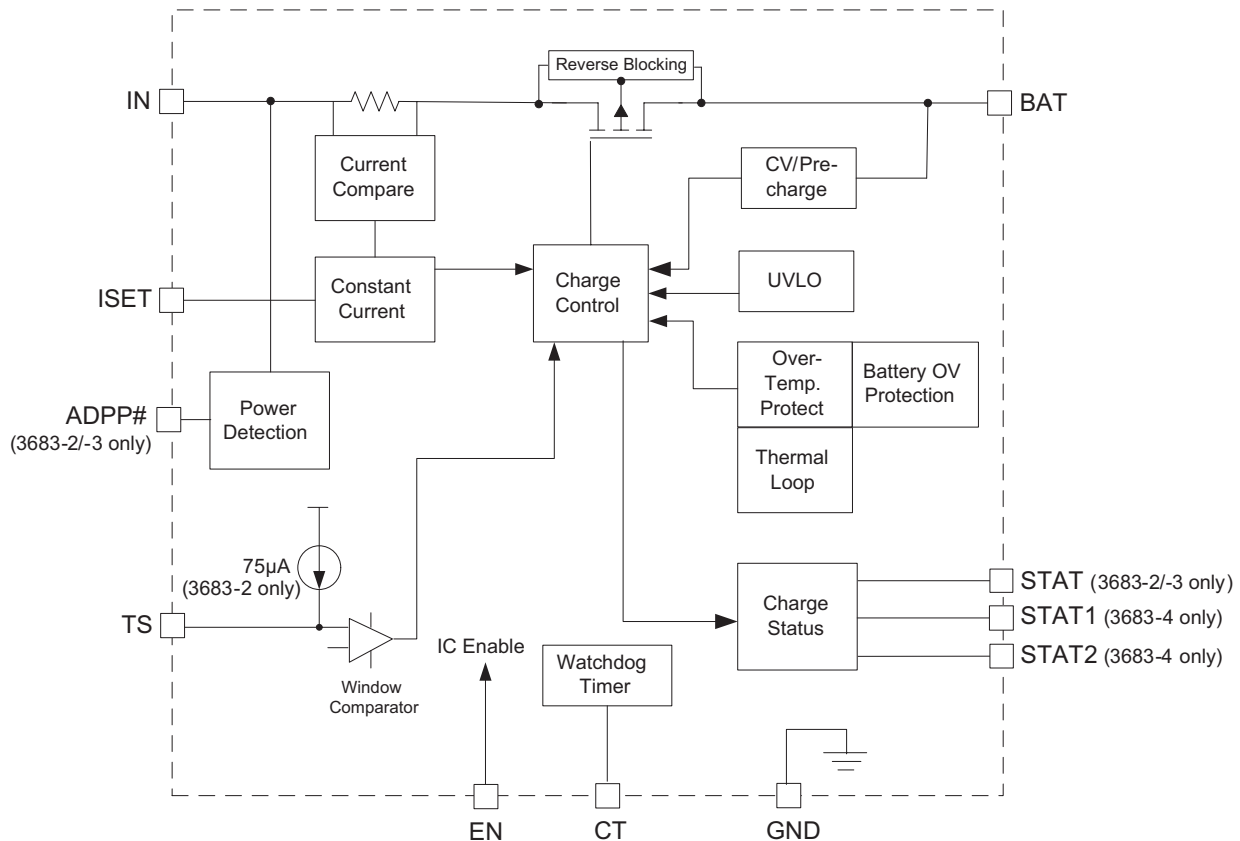

Functional Description

The AAT3683 is a high performance battery charger designed to charge single-cell lithium-ion or lithium-polymer batteries with up to 1A of current from an external power source. It is a stand-alone charging solution, with just one external component required for complete functionality.

The AAT3683 precisely regulates battery charge voltage and current for 4.2V lithium-ion/polymer battery cells with constant current level being programmed up to 1A for rapid charging applications. The charge termination current can be programmed by an external resistor.

The AAT3683 is rated for operation from -40°C to +85°C. In the event of operating ambient temperatures exceeding the power dissipation abilities of the device package for a given constant current charge level, the charge control will enter into thermal limit.

AAT3683-2 and -3 provide one status monitor output pin (STAT) by directly driving one external LED to indicate the battery charging state. AAT3683-4 provides two status pins to indicate the battery charging state.

Device junction temperature and charge state are fully monitored for fault conditions. In the event of an over-voltage or over-temperature failure, the device will automatically shut down, protecting the charging device, control system, and the battery under charge.

During battery charging, the device temperature will rise. In some cases with adapter (ADP) charging, the power dissipation in the device may cause the junction temperature to rise to close to its thermal shutdown threshold. In the event of an internal over-temperature condition caused by excessive ambient operating temperature or excessive power dissipation condition, the AAT3683 enables a digi-

tally controlled thermal loop system that will reduce the charging current to prevent the device from thermal shutdown. The digital thermal loop will maintain the maximum possible battery charging current for the given set of input to output power dissipation and ambient temperature conditions.

The digital thermal loop control is dynamic in the sense that it will continue to adjust the battery charging current as operating conditions change.

The digital thermal loop will reset and resume normal operation when the power dissipation or over-temperature conditions are removed.

Battery Charging Operation

Figure 1 illustrates the entire battery charging profile or operation, which consists of three phases:

1. Preconditioning (Trickle) Charge
2. Constant Current Charge
3. Constant Voltage Charge

Battery Preconditioning

Battery charging commences only after the AAT3683 checks several conditions in order to maintain a safe charging environment. The input supply must be above the minimum operating voltage (V_{UVLO}) and the enable pin must be high. When the battery is connected to the BAT pin, the AAT3683 checks the condition of the battery and determines which charging mode to apply. If the

battery voltage is below the preconditioning voltage threshold, V_{MIN} , then the AAT3683 begins preconditioning the battery cell (trickle charging) by charging at 10% of the programmed constant current. For example, if the programmed current is 500mA, then the preconditioning mode (trickle charge) current is 50mA. Battery cell preconditioning (trickle charging) is a safety precaution for deeply discharged cells and will also reduce the power dissipation in the internal series pass MOSFET when the input-output voltage differential is at the greatest potential.

Constant Current Charging

Battery cell preconditioning continues until the battery voltage reaches the preconditioning voltage threshold, V_{MIN} . At this point, the AAT3683 begins constant current charging. The current level for this mode is programmed using a single resistor from the ISET pin to ground. Programmed current can be set at a minimum 100mA up to a maximum of 1A.

Constant Voltage Charging

Constant current charging will continue until such time that the battery voltage reaches the voltage regulation point, V_{BAT_EOC} . When the battery voltage reaches V_{BAT_EOC} , the AAT3683 will transition to constant voltage mode. The regulation voltage is factory programmed to a nominal 4.2V and will continue charging until the charge termination current is reached.

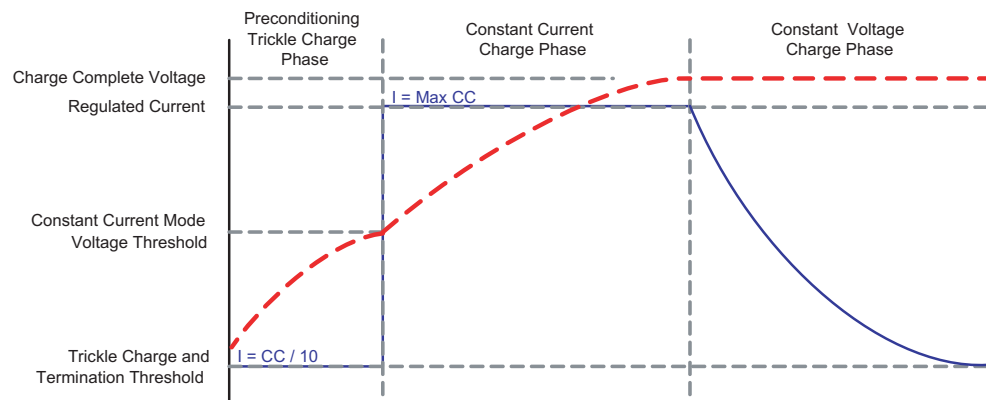
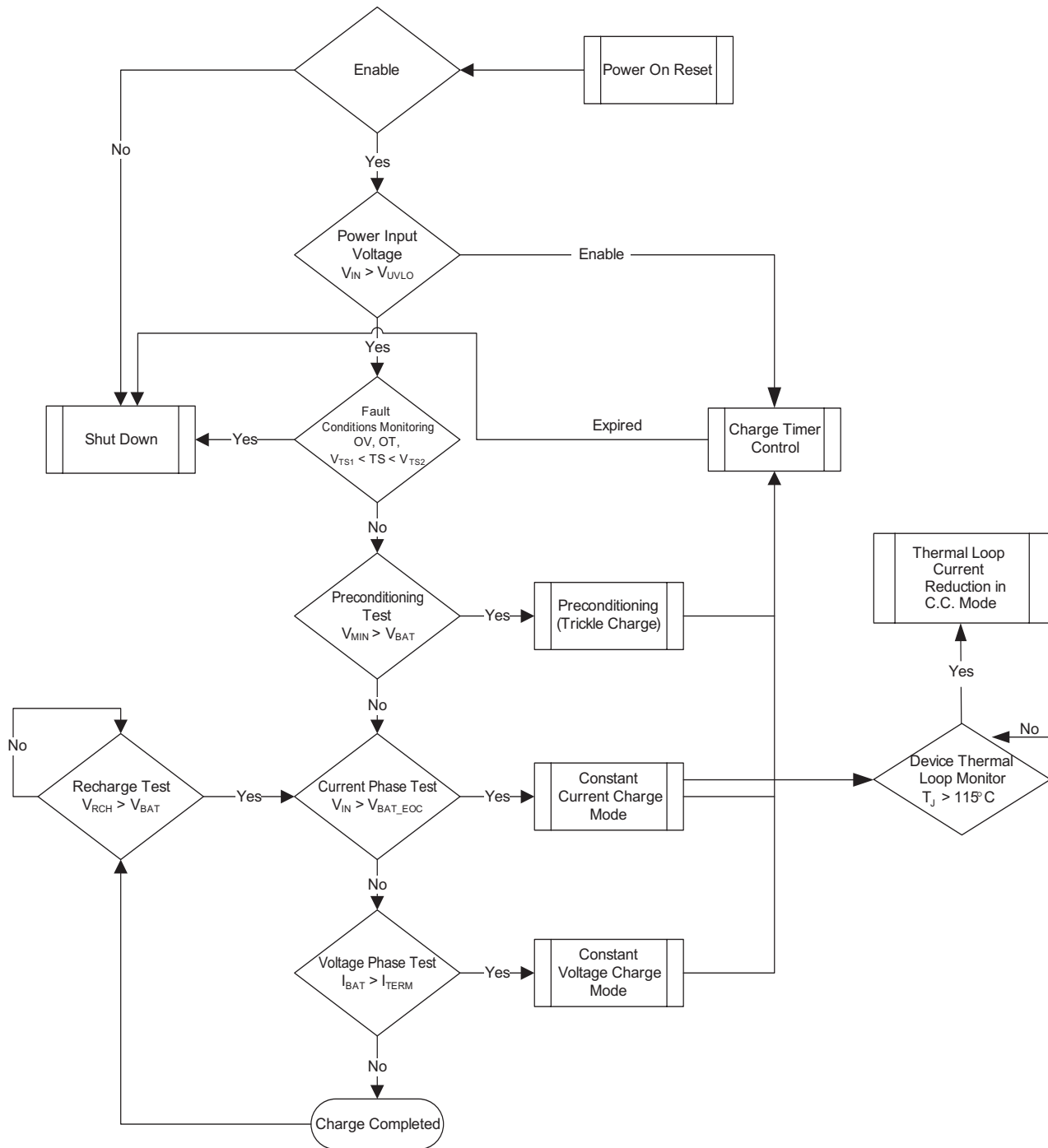

Figure 1: Current vs. Voltage Profile During Charging Phases.

System Operation Flow Chart



Application Information

Adapter or USB Power Input

Constant current charge levels up to 1A may be programmed by the user when powered from a sufficient input power source. The AAT3683 will operate from the adapter input over a 4.0V to 6.5V range. The constant current mode fast charge current for the adapter input is set by the R_{SET} resistor connected between ISET and ground. Refer to Table 4 for recommended R_{SET} values for a desired constant current charge level.

Adapter Input Charge Inhibit and Resume

The AAT3683 has a UVLO and power on reset feature so that if the input supply to the ADP pin drops below the UVLO threshold, the charger will suspend charging and shut down. When power is re-applied to the IN pin or the UVLO condition recovers, the system charge control will assess the state of charge on the battery cell and will automatically resume charging in the appropriate mode for the condition of the battery.

Digital Thermal Loop Control

Due to the integrated nature of the linear charging control pass device for the adapter mode, a special thermal loop control system has been employed to maximize charging current under all operation conditions. The thermal management system measures the internal circuit die temperature and reduces the fast charge current when the device exceeds a preset internal temperature control threshold. Once the thermal loop control becomes active, the fast charge current is initially reduced by a factor of 0.44.

The initial thermal loop current can be estimated by the following equation:

$$I_{TLOOP} = I_{CH_CC} \cdot 0.44$$

The thermal loop control re-evaluates the circuit die temperature every three seconds and adjusts the fast charge current back up in small steps to the full fast charge current level or until an equilibrium current is discovered and maximized for the given ambient temperature condition. The thermal loop

controls the system charge level; therefore, the AAT3683 will always provide the highest level of constant current in the fast charge mode possible for any given ambient temperature condition.

Enable / Disable

The AAT3683 provides an enable function to control the charger IC on and off. The enable (EN) pin is internally pulled down. When pulled to a logic high level, AAT3683 is enabled. When left open or pulled to a logic low level, the AAT3683 will be shut down. Charging will be halted regardless of the battery voltage or charging state. When the device is re-enabled, the charge control circuit will automatically reset and resume charging functions with the appropriate charging mode based on the battery charge state and measured cell voltage on the BAT pin.

Programming Charge Current

The constant current mode charge level is user programmed with a set resistor placed between the ISET pin and ground. The accuracy of the constant charge current, as well as the preconditioning trickle charge current, is dominated by the tolerance of the set resistor used. For this reason, a 1% tolerance metal film resistor is recommended for the set resistor function. The constant charge current levels from 100mA to 1A may be set by selecting the appropriate resistor value from Table 1.

Constant Charging Current (mA)	Set Resistor Value (kΩ)
100	16.2
200	8.06
300	5.36
400	4.02
500	3.24
600	2.67
700	2.26
800	2
900	1.78
1000	1.58

Table 1: R_{SET} Values.

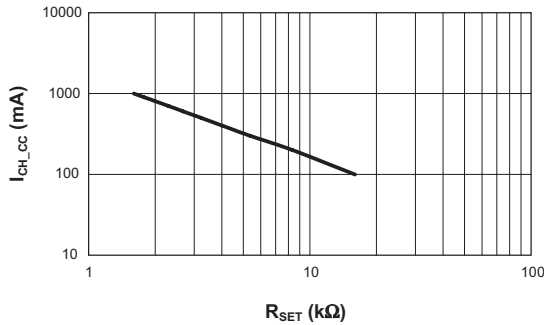

Figure 2: Constant Charging Current vs. Set Resistor Values.

Programmable Charge Termination Current

The charge termination current I_{CH_TERM} can be programmed by connecting a resistor from TERM to GND:

$$I_{CH_TERM} = \frac{15\mu A \cdot R_{TERM}}{2V} \cdot I_{CH_CC}$$

If the TERM pin is left open, the termination current will set to 10% of the constant charging current as the default value.

When the charge current drops to the defaulted 10% of the programmed charge current level or programmed terminated current in the constant voltage mode, the device terminates charging and goes into a sleep state. The charger will remain in this sleep state until the battery voltage decreases to a level below the battery recharge voltage threshold (V_{RCH}).

Consuming very low current in sleep state, the AAT3683 minimizes battery drain when it is not charging. This feature is particularly useful in applications where the input supply level may fall below the battery charge or under-voltage lockout level. In such cases where the AAT3683 input voltage drops, the device will enter sleep state and automatically resume charging once the input supply has recovered from the fault condition.

Charge Status Output

The AAT3683 provides battery charge status via a status pin (AAT3683-4 provides battery charge status via two status pins). This pin is internally connected to an N-channel open-drain MOSFET, which can be used drive an external LED. The status pin can indicate the following conditions (AAT3683-2, AAT3683-3):

Event Description	STATUS
No battery charging activity	OFF
Battery charging via adapter or USB port	ON
Charging completed	OFF

Table 2: LED Status Indicator (AAT3683-2/AAT3683-3).

The status pins can indicate the following conditions (AAT3683-4):

Event Description	STAT1	STAT2
Charge enabled without battery	FLASH ¹	FLASH ¹
Battery charging	ON	OFF
Charge completed	OFF	ON
Fault	OFF	OFF

Table 3: LEDs Status Indicator. (AAT3683-4).

The LED should be biased with as little current as necessary to create reasonable illumination; therefore, a ballast resistor should be placed between the LED cathode and the STAT pin. LED current consumption will add to the overall thermal power budget for the device package, hence it is good to keep the LED drive current to a minimum. 2mA should be sufficient to drive most low-cost green or red LEDs. It is not recommended to exceed 8mA for driving an individual status LED.

1. Flashing rate depends on output capacitance.

The required ballast resistor values can be estimated using the following formula:

$$R_{\text{BALLAST}} = \frac{(V_{\text{IN}} - V_{\text{F(LED)}})}{I_{\text{LED}}}$$

Example:

$$R_{\text{BALLAST}} = \frac{(5.0\text{V} - 2.0\text{V})}{2\text{mA}} = 1.5\text{k}\Omega$$

Note: Red LED forward voltage (V_{F}) is typically 2.0V @ 2mA.

Protection Circuitry

Programmable Watchdog Timer

The AAT3683 contains a watchdog timing circuit to shut down charging functions in the event of a defective battery cell not accepting a charge over a preset period of time. Typically, a 0.1 μF ceramic capacitor is connected between the CT pin and ground. When a 0.1 μF ceramic capacitor is used, the device will time out a shutdown condition if the trickle charge mode exceeds 25 minutes and a combined trickle charge plus constant current mode of 3 hours. When the device transitions to the constant voltage mode, the timing counter is reset and will time out after an additional 3 hours if the charge current does not drop to the charge termination level.

The 3683-4 has a battery fault detector, which, when used in conjunction with a 0.1 μF capacitor on the CT pin, outputs a 1Hz signal with 50% duty cycle at the STAT1 pin in the event of a timeout while in the trickle charge mode.

Mode	Time
Trickle Charge (TC) Time Out	25 minutes
Trickle Charge (TC) + Constant Current (CC) Mode Time Out	3 hours
Constant Voltage (VC) Mode Time Out	3 hours

Table 4: Summary for a 0.1 μF Ceramic Capacitor Used for the Timing Capacitor.

The CT pin is driven by a constant current source and will provide a linear response to increases in the timing capacitor value. Thus, if the timing capacitor were to be doubled from the nominal 0.1 μF value, the time-out periods would be doubled.

If the programmable watchdog timer function is not needed, it can be disabled by terminating the CT pin to ground. The CT pin should not be left floating or un-terminated, as this will cause errors in the internal timing control circuit.

The constant current provided to charge the timing capacitor is very small, and this pin is susceptible to noise and changes in capacitance value. Therefore, the timing capacitor should be physically located on the printed circuit board layout as close as possible to the CT pin. Since the accuracy of the internal timer is dominated by the capacitance value, a 10% tolerance or better ceramic capacitor is recommended. Ceramic capacitor materials, such as X7R and X5R types, are a good choice for this application.

Over-Voltage Protection

An over-voltage event is defined as a condition where the voltage on the BAT pin exceeds the maximum battery charge voltage and is set by the over-voltage protection threshold (V_{OVP}). If an over-voltage condition occurs, the AAT3683 charge control will shut down the device until the voltage on the BAT pin drops below V_{OVP} . The AAT3683 will resume normal charging operation after the over-voltage condition is removed. During an over-voltage event, the STAT LEDs (3683-4 only) will report a system fault.

Over-Temperature Shutdown

The AAT3683 has a thermal protection control circuit which will shut down charging functions should the internal die temperature exceed the preset thermal limit threshold. Once the internal die temperature falls below the thermal limit, normal operation will resume the previous charging state.

Battery Temperature Fault Monitoring

In the event of a battery over-temperature condition, the charge control will turn off the internal pass device and report a battery temperature fault on the DATA pin function. The STAT LEDs will also display a system fault. After the system recovers from a temperature fault, the device will resume charging operation.

The AAT3683-2 checks battery temperature before starting the charge cycle, as well as during all stages of charging. This is accomplished by monitoring the voltage at the TS pin. This system is intended for use with negative temperature coefficient thermistors (NTC) which are typically integrated into the battery package. Most of the commonly used NTC thermistors in battery packs are approximately 10kΩ at room temperature (25°C). The TS pin (3683-2 only) has been specifically designed to source 75μA of current to the thermistor. The voltage on the TS pin resulting from the resistive load should stay within a window of 331mV to 2.39V. If the battery becomes too hot during charging due to an internal fault or excessive constant charge current, the thermistor will heat up and reduce in value, pulling the TS pin voltage lower than the TS1 threshold, and the AAT3683-2 will stop charging until the condition is removed, when charging will be resumed.

If the use of the TS pin function is not required by the system, it should be terminated to ground using a 10kΩ resistor. Alternatively, on the AAT3683-2, the TS pin may be left open.

For AAT3683-3 and -4, the internal battery temperature sensing system is comprised of two comparators which establish a voltage window for safe operation. The thresholds for the TS operating window are bounded by the TS1 and TS2 specifications. Referring to the electrical characteristics table in this datasheet, the TS1 threshold = $0.30 \cdot V_{IN}$ and the TS2 threshold = $0.60 \cdot V_{IN}$.

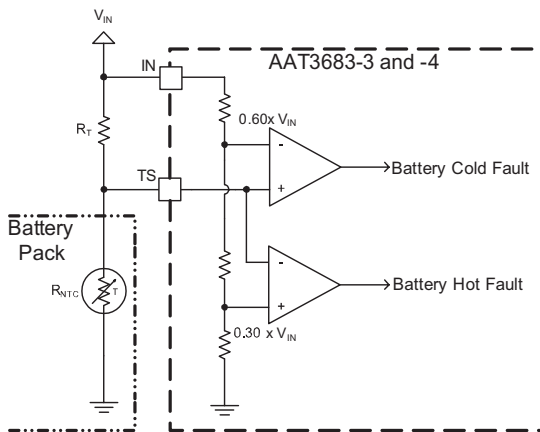

Figure 3: AAT3683-3 and -4 Battery Temperature Sense Circuit.

Thermal Considerations

The AAT3683 is offered in two packages (STDFN2.2x2.2-10 and QFN33-16) both of which can provide up to 2W of power dissipation when properly bonded to a printed circuit board and have a maximum thermal resistance of 50°C/W. Many considerations should be taken into account when designing the printed circuit board layout, as well as the placement of the charger IC package in proximity to other heat generating devices in a given application design. The ambient temperature around the charger IC will also have an effect on the thermal limits of a battery charging application. The maximum limits that can be expected for a given ambient condition can be estimated by the following discussion.

First, the maximum power dissipation for a given situation should be calculated:

$$P_{D(MAX)} = \frac{(T_J - T_A)}{\theta_{JA}}$$

Where:

$P_{D(MAX)}$ = Maximum Power Dissipation (W)

θ_{JA} = Package Thermal Resistance (°C/W)

T_J = Thermal Loop Entering Threshold (°C)
[115°C]

T_A = Ambient Temperature (°C)

Figure 4 shows the relationship of maximum power dissipation and ambient temperature of AAT3683.

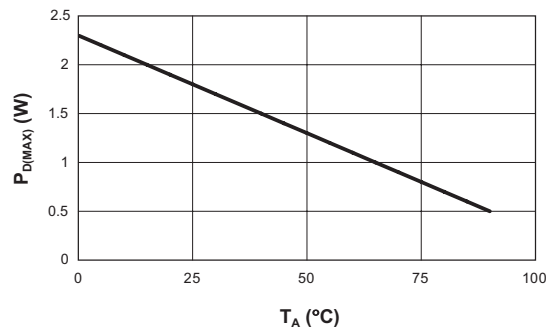

Figure 4: Maximum Power Dissipation Before Entering Thermal Loop.

Next, the power dissipation can be calculated by the following equation:

$$P_D = [(V_{IN} - V_{BAT}) \cdot I_{CH} + (V_{IN} \cdot I_{OP})]$$

Where:

P_D = Total Power Dissipation by the Device

V_{IN} = Input Voltage

V_{BAT} = Battery Voltage as Seen at the BAT Pin

I_{CH} = Constant Charge Current Programmed for the Application

I_{OP} = Quiescent Current Consumed by the Charger IC for Normal Operation [0.3mA]

By substitution, we can derive the maximum charge current before reaching the thermal limit condition (thermal loop). The maximum charge current is the key factor when designing battery charger applications.

$$I_{CH(MAX)} = \frac{(P_{D(MAX)} - V_{IN} \cdot I_{OP})}{V_{IN} - V_{BAT}}$$

$$I_{CH(MAX)} = \frac{\frac{(T_J - T_A)}{\theta_{JA}} - V_{IN} \cdot I_{OP}}{V_{IN} - V_{BAT}}$$

In general, the worst condition is the greatest voltage drop across the charger IC, when battery voltage is charged up to the preconditioning voltage threshold and before entering thermal loop regulation. Figure 5 shows the maximum charge current in different ambient temperatures.

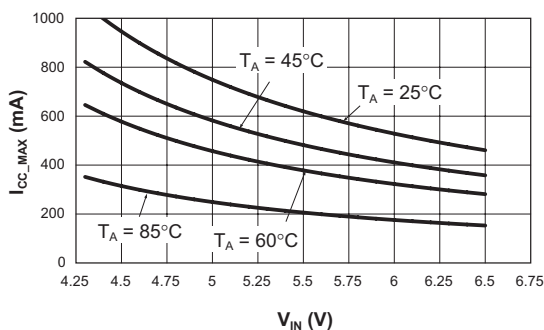

Figure 5: Maximum Charging Current Before the Digital Thermal Loop Becomes Active.

Capacitor Selection

Input Capacitor

In general, it is good design practice to place a decoupling capacitor between the IN pin and GND. An input capacitor in the range of 1 μ F to 22 μ F is recommended. If the source supply is unregulated, it may be necessary to increase the capacitance to keep the input voltage above the under-voltage lockout threshold during device enable and when battery charging is initiated. If the AAT3683 adapter input is to be used in a system with an external power supply source, such as a typical AC-to-DC wall adapter, then a C_{IN} capacitor in the range of 10 μ F should be used. A larger input capacitor in this application will minimize switching or power transient effects when the power supply is "hot plugged" in.

Output Capacitor

The AAT3683 only requires a 1 μ F ceramic capacitor on the BAT pin to maintain circuit stability. This value should be increased to 10 μ F or more if the battery connection is made any distance from the charger output. If the AAT3683 is to be used in applications where the battery can be removed from the charger, such as with desktop charging cradles, an output capacitor greater than 10 μ F may be required to prevent the device from cycling on and off when no battery is present.

Printed Circuit Board Layout Considerations

For the best results, it is recommended to physically place the battery pack as close as possible to the AAT3683 BAT pin. To minimize voltage drops on the PCB, keep the high current carrying traces adequately wide. When designing with >500mA charging current system, a multilayer PCB design is highly recommended. Putting thermal vias on the thermal pad design will effectively transfer heat from the top metal layer of the PCB to the inner or bottom layers. The number of thermal vias will depend on the application and power dissipation. Refer to the AAT3683 evaluation board for a good layout example.

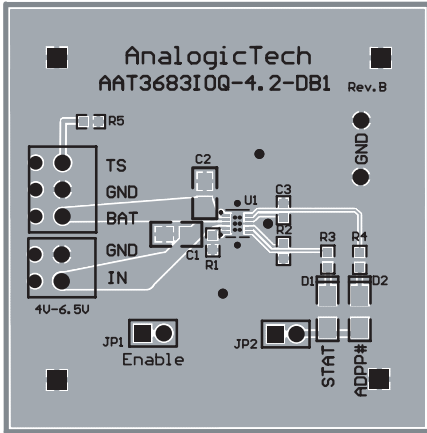

Figure 6: AAT3683-2 Evaluation Board Top Side Layout.

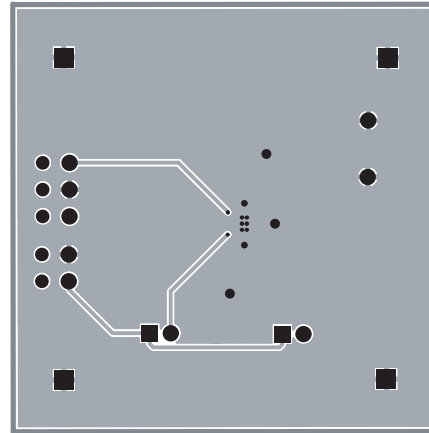

Figure 7: AAT3683-2 Evaluation Board Middle Layer.

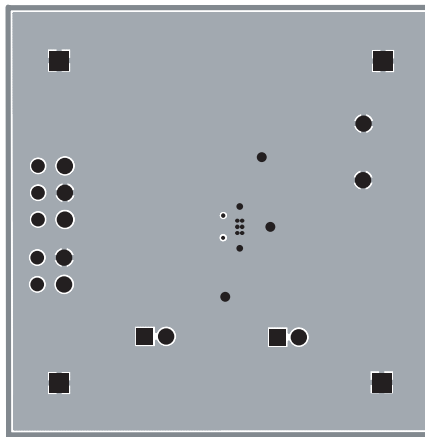

Figure 8: AAT3683-2 Evaluation Board Bottom Side Layout.

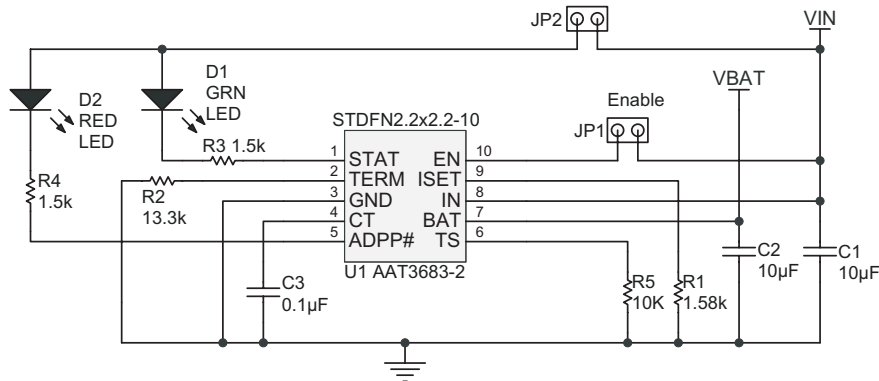
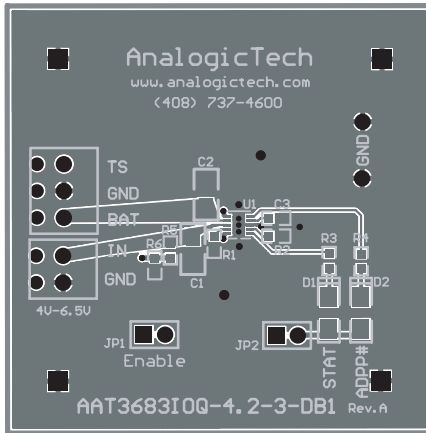
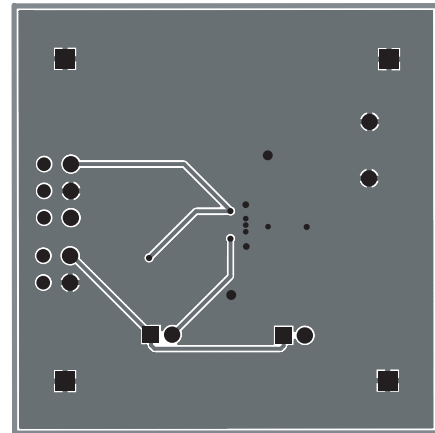

Figure 9: AAT3683-2 Evaluation Board Schematic.



**Figure 10: AAT3683-3 Evaluation Board
Top Side Layout.**



**Figure 11: AAT3683-3 Evaluation Board
Middle Layer.**

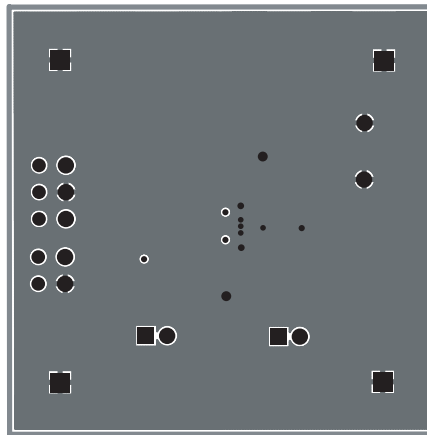

**Figure 12: AAT3683-3 Evaluation Board
Bottom Side Layout.**

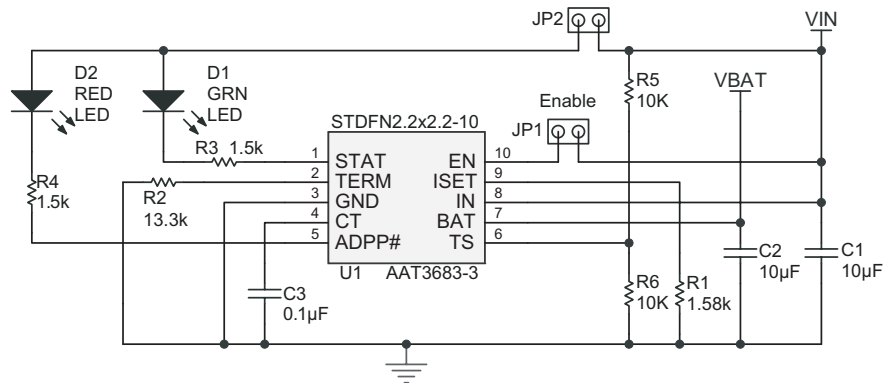

Figure 13: AAT3683-3 Evaluation Board Schematic.

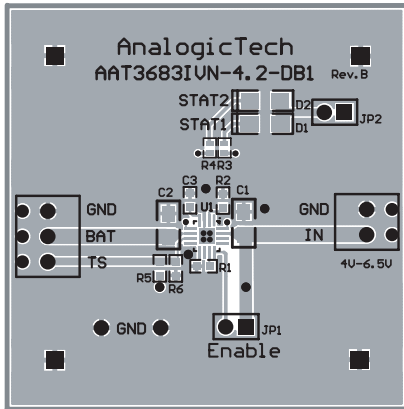

Figure 14: AAT3683-4 Evaluation Board Top Side Layout.

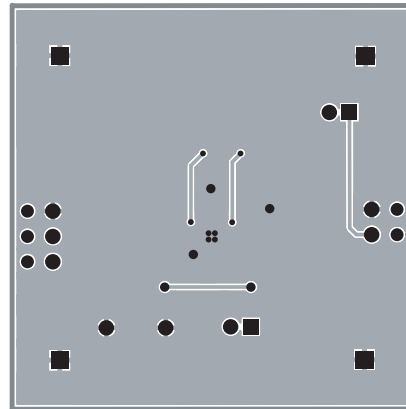

Figure 15: AAT3683-4 Evaluation Board Middle Layer.

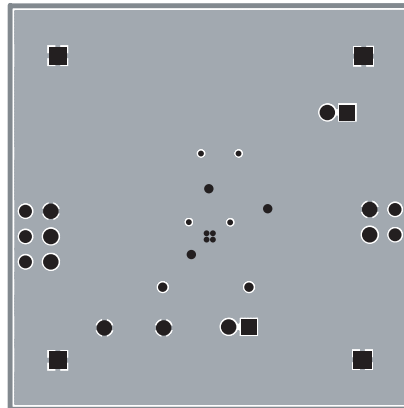

Figure 16: AAT3683-4 Evaluation Board Bottom Side Layout.

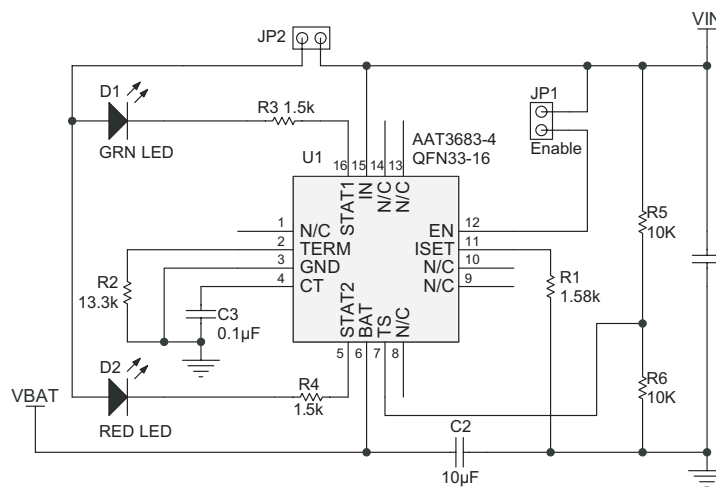

Figure 17: AAT3683-4 Evaluation Board Schematic.

Component	Part#	Description	Manufacturer
U1	AAT3683IOQ-4.2-2	1A Linear Li-Ion Battery Charger, 2.2x2.2mm STDFN-10 Package	AnalogicTech
R1	Chip Resistor	1.58K Ω , 1%, 1/4W 0603	Vishay
R2	Chip Resistor	13.3K Ω , 1%, 1/4W 0603	Vishay
R3, R4	Chip Resistor	1.5K Ω , 5%, 1/4W 0402	Vishay
R5	Chip Resistor	10K Ω , 1%, 1/4W 0603	Vishay
C1, C2	ECJ-1VB0J106M	CER 10 μ F 6.3V 10% X5R 0603	Panasonic
C3	GRM188R71C104KA01	CER 0.1 μ F 6.3V 10% X7R 0603	Murata
JP1	PRPN401PAEN	Conn. Header, 2mm zip	Sullins Electronics
D1	CMD15-21VGC/TR8	Green LED 1206	Chicago Miniature Lamp
D2	CMD15-21SRC/TR8	Red LED 1206	Chicago Miniature Lamp

Table 5: AAT3683-2 Evaluation Board Bill of Materials.

Component	Part#	Description	Manufacturer
U1	AAT3683IOQ-4.2-3	1A Linear Li-Ion Battery Charger; 2.2x2.2mm STDFN-10 Package	AnalogicTech
R1	Chip Resistor	1.582K Ω , 1%, 1/4W; 0603	Vishay
R2	Chip Resistor	13.3K Ω , 1%, 1/4W; 0603	Vishay
R3, R4	Chip Resistor	1.5K Ω , 5%, 1/4W; 0402	Vishay
R5, R6	Chip Resistor	10K Ω , 1%, 1/4W; 0603	Vishay
C1, C2	ECJ-1VB0J106M	CER 10 μ F 6.3V 10% X5R 0603	Panasonic
C3	GRM188R71C104KA01	CER 0.1 μ F 6.3V 10% X7R 0603	Murata
JP1	PRPN401PAEN	Conn. Header, 2mm zip	Sullins Electronics
D1	CMD15-21VGC/TR8	Green LED; 1206	Chicago Miniature Lamp
D2	CMD15-21SRC/TR8	Red LED; 1206	Chicago Miniature Lamp

Table 6: AAT3683-3 Evaluation Board Bill of Materials.

Component	Part#	Description	Manufacturer
U1	AAT3683IVN-4.2-4	1A Linear Li-Ion Battery Charger, QFN33-16 Package	AnalogicTech
R1	Chip Resistor	1.58K Ω , 1%, 1/4W 0603	Vishay
R2	Chip Resistor	13.3K Ω , 1%, 1/4W 0603	Vishay
R3, R4	Chip Resistor	1.5K Ω , 5%, 1/4W 0402	Vishay
R5, R6	Chip Resistor	10K Ω , 1%, 1/4W 0603	Vishay
C1, C2	GRM21BR61A106KE19	CER 10 μ F 10V 10% X5R 0805	Murata
C3	GRM188R71C104KA01	CER 0.1 μ F 6.3V 10% X7R 0603	Murata
JP1	PRPN401PAEN	Conn. Header, 2mm zip	Sullins Electronics
D1	CMD15-21VGC/TR8	Green LED 1206	Chicago Miniature Lamp
D2	CMD15-21SRC/TR8	Red LED 1206	Chicago Miniature Lamp

Table 7: AAT3683-4 Evaluation Board Bill of Materials.

Ordering Information

Package	Marking ¹	Part Number (Tape and Reel) ²
STDFN-10 (2.2x2.2mm)	WIXYY	AAT3683IOQ-4.2-2-T1
STDFN-10 (2.2x2.2mm)	WJXYY	AAT3683IOQ-4.2-3-T1
QFN33-16	WKXYY	AAT3683IVN-4.2-4-T1



All AnalogicTech products are offered in Pb-free packaging. The term “Pb-free” means semiconductor products that are in compliance with current RoHS standards, including the requirement that lead not exceed 0.1% by weight in homogeneous materials. For more information, please visit our website at <http://www.analogictech.com/pbfree>.

1. XYY = assembly and date code.

2. Sample stock is generally held on part numbers listed in **BOLD**.

Package Information¹

STDFN2.2x2.2-10

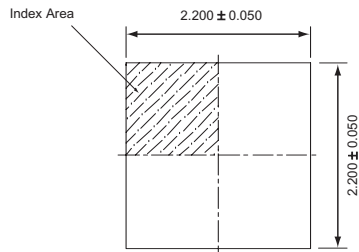

Top View

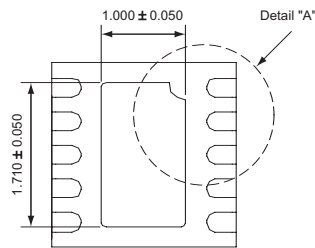

Bottom View

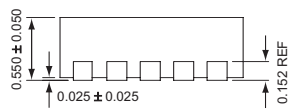

Side View

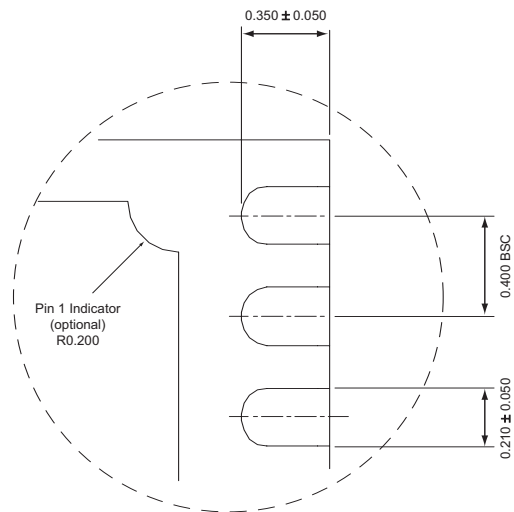

Detail "A"

All dimensions in millimeters.

1. The leadless package family, which includes QFN, TQFN, DFN, TDFN and STDFN, has exposed copper (unplated) at the end of the lead terminals due to the manufacturing process. A solder fillet at the exposed copper edge cannot be guaranteed and is not required to ensure a proper bottom solder connection.

