

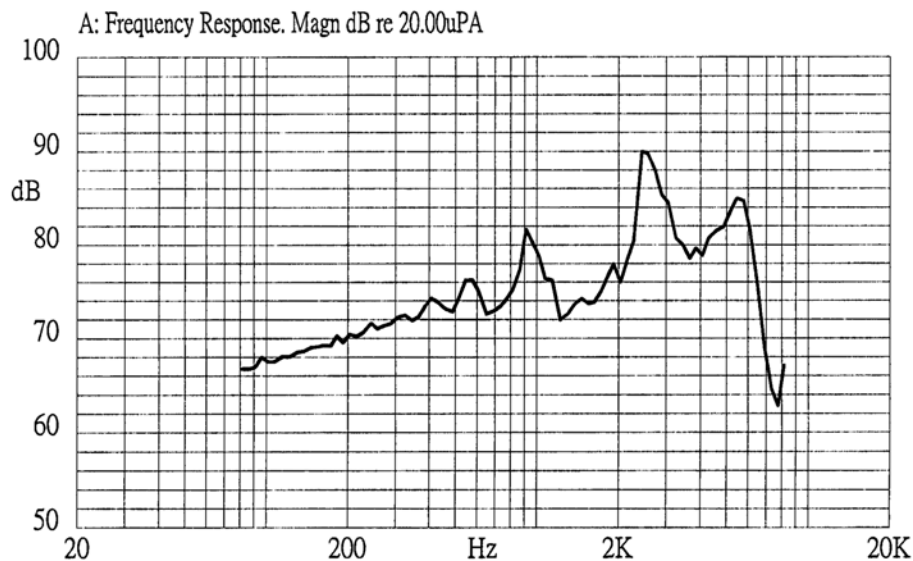
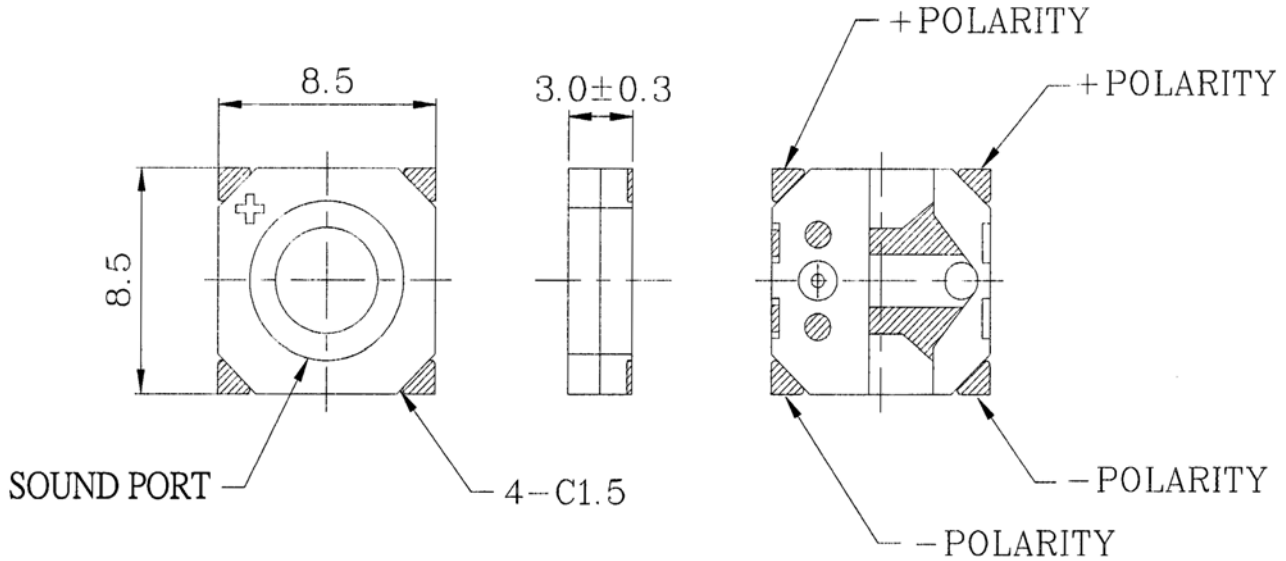
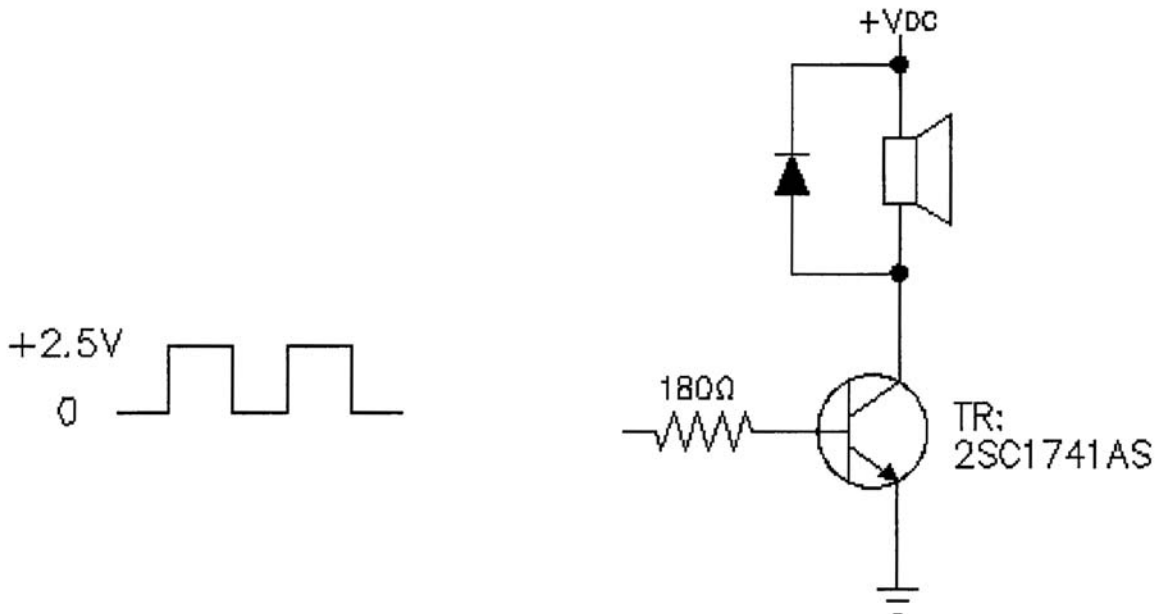

Specifications

Rated voltage	3.6 Vo-p	
Operating voltage	3.0 - 5.0 Vo-p	
Mean current	80 mA max.	
Coil resistance	20 ±3 Ω	Applying rated voltage, 2730 Hz square wave, ½ duty
Sound output	Min. 85 (Typical 90) dBA	Distance at 5cm (A-weight free air). Applying rated voltage of 2730 Hz, square wave, ½ duty.
Rated frequency	2730 Hz	
Operating temperature	-30 ~ +70° C	
Storage temperature	-40 ~ +85° C	
Dimensions	L8.5 x W8.5 x H3.2 mm	See attached drawing
Weight	0.60 g	
Material	L.C.P. (White)	
Terminal	SMD type (Au Plating)	See attached drawing
RoHS	yes	

Frequency Response Curve

Appearance Drawing

 Tolerance: ± 0.5

Measurement Method

Mechanical Characteristics

Item	Test Condition	Evaluation Standard
Solderability	Lead terminals are immersed in solder bath of $+270 \pm 5^{\circ}\text{C}$ for 3 ± 1 seconds.	95% surface of lead pads must be covered with fresh solder.
Soldering Heat Resistance	The product follows the reflow temperature curve to test its reflow thermo stability.	No in interference in operation.
Terminal Mechanical Strength	Lead pads shall be soldered onto the pc board and the force of 9.8 N (1.0 kg) shall be applied behind the part for 10 seconds.	No damage or cutting off.
Vibration	The buzzer will be measured after applying a vibration amplitude of 1.5 mm with 10 to 55 Hz band of vibration frequency to each of the 3 perpendicular directions for 2 hours.	After the test, the part shall meet specifications without any damage to the appearance and the SPL should be within ± 10 dBA of the initial SPL.
Drop Test	The part is to be dropped from a height of 75 cm onto a 40 mm thick wooden board 3 times in 3 axis (X, Y, Z) for a total of 9 drops.	

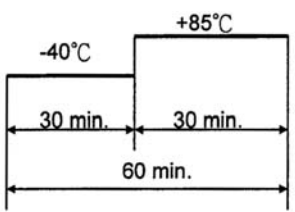
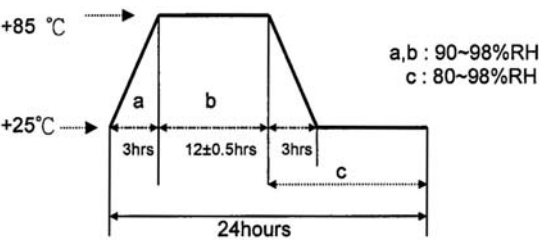
Environment Test

Item	Test Condition	Evaluation Standard
High temp. test	The part will be subjected to $+85^{\circ}\text{C}$ for 96 hours.	After the test, the part shall meet specifications without any damage to the appearance or performance and the SPL should be within ± 10 dBA of the initial SPL.
Low temp. test	The part will be subjected to -40°C for 96 hours	
Thermal shock	The part will be subjected to 10 cycles. One cycle will consist of: <div style="text-align: center;">  </div>	
Temp./Humidity cycle	The part shall be subjected to 10 cycles. One cycle will last for 24 hours and consist of: <div style="text-align: center;">  </div>	

Mechanical Characteristics

Item	Test Condition	Evaluation Standard
Operating (Life Test)	1. Continuous life test: The part will be subjected to 72 hours at +55°C with 3.6 V, 2730 Hz applied. 2. Intermittent life test: A duty cycle of 1 minute on, 1 minute off, a minimum of 10,000 times at room temp (+25±10°C) with 3.6 V, 2730 Hz applied.	After the test, the part shall meet specifications without any damage to the appearance. After 4 hours at +25°C, the SPL should be within ±10 dBA of the initial SPL.

Test Conditions

Standard Test Condition	a) Temperature: +5 ~ +35°C	b) Humidity: 45 - 85%	c) Pressure: 860 - 1060 mbar
Judgement Test Condition	a) Temperature: +25±2°C	b) Humidity: 60 - 70%	c) Pressure: 860 - 1060 mbar

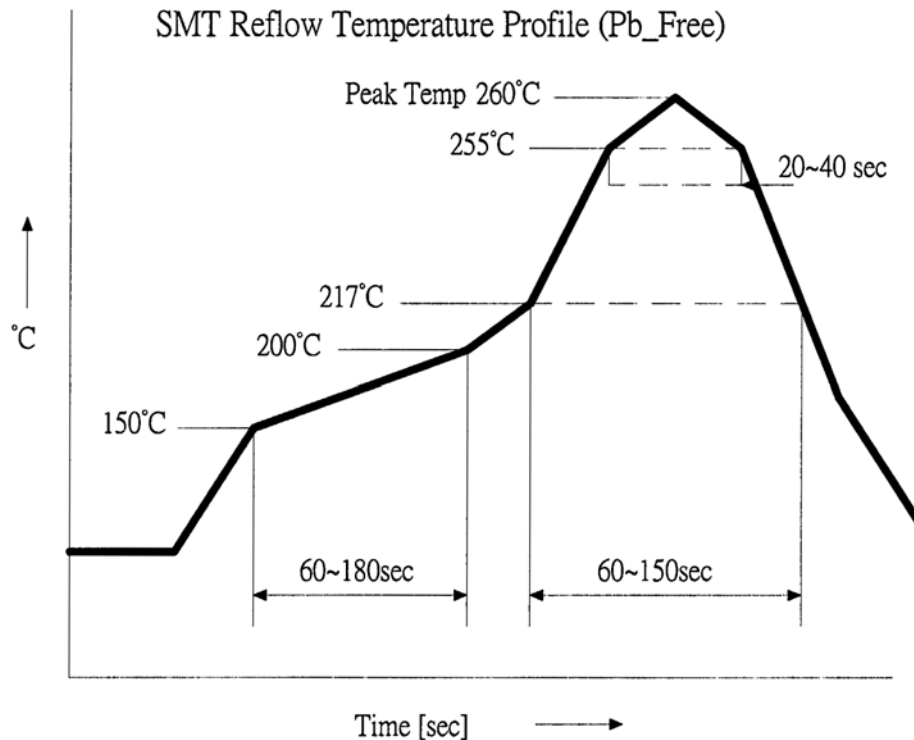
Recommended Temperature Profile for Reflow Oven

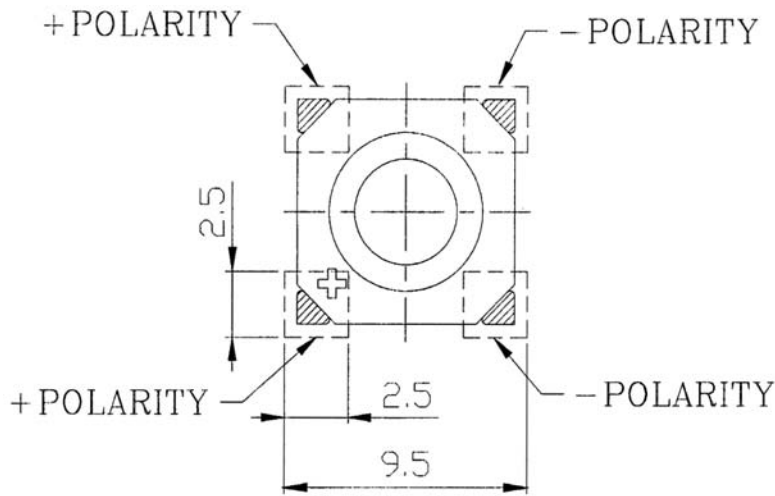
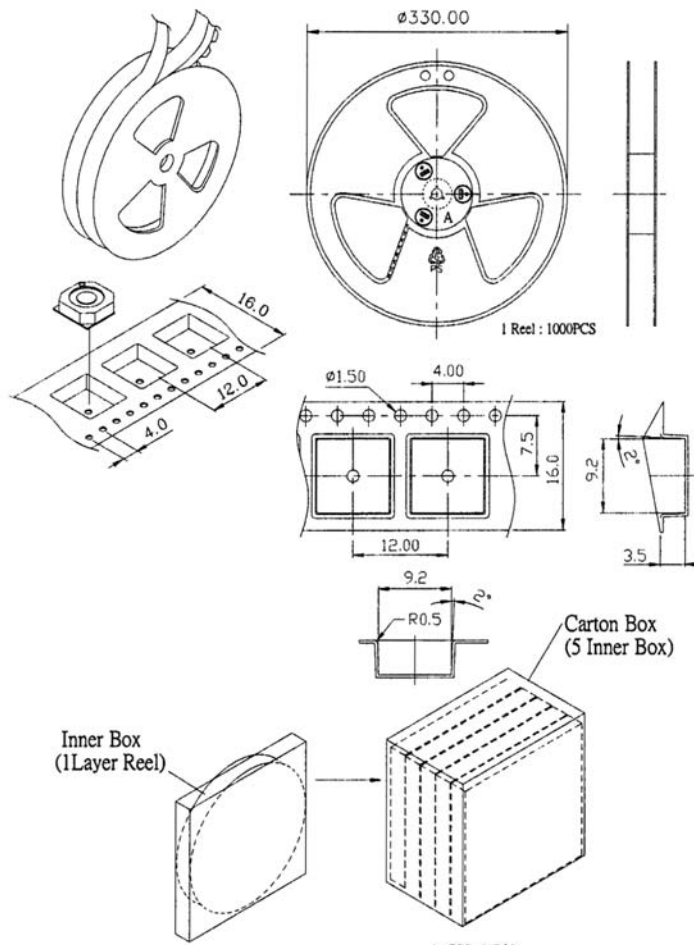
Recommended Land Pattern

Packaging

Inner Box	340mmx340mmx40mm	1x1000PCS=1000PCS
Carton Box	350mmx175mmx355mm	5x1000PCS=5000PCS

1. CSS-14B20
2. RoHS Compliant