

#### FEATURES

- Interfaces Directly with an 8 Bit Microprocessor
- Wide Application Range
- Reduced Number of Counter ICs
- Reduced Parts Count
- 40 Pin Plastic Dual Inline Package
- 60 Pin Quad Flat Package
- + 5 V Single Power Supply
- 32 Bit Command Counter
- 24 Bit Error Counter
- Adjustable Output Rate to the D/A
- 10 MHz Clock

#### DESCRIPTION

The KM3702AD/AQ is a position control CMOS LSI which monitors the difference between the COMMAND ( $\pm$ COM) and FEEDBACK ( $\pm$ FB) pulses, under the conditions set by the CPU, and uses this position error to output a bit pattern to the D/A converter. The KM3702AD/AQ uses a single +5V power supply and has TTL-compatible input and output. Its system clock (CP) frequency is 10 MHz maximum. To keep track of the input pulses, there are two binary up/down counters: COMMAND COUNTER - 32 bits, cumulative value of +COM and -COM input pulses, and ERROR COUNTER - 24 bits, difference between +COM and -COM input and +FB and -FB input pulses.  $\pm$ COM and  $\pm$ FB pulses can be input either synchronously or asynchronously. Data can be preset into these counters, and the counter values can be read out by the host CPU. Commands from the CPU can be used to create a zero clamp condition or a floating state condition on the outputs to the D/A converter. Zero clamp means that for the purposes of the D/A converter, the output pattern will be zero even though the ERROR COUNTER continues to function normally.

#### APPLICATIONS

- Motion Control Systems
- Robotics
- Drawing Machines
- Electrical Discharge Machines
- Special Machinery

\*See KM3702AD/AQ Operation Manual for further detail.

2

KM3702A



BLOCK DIAGRAM

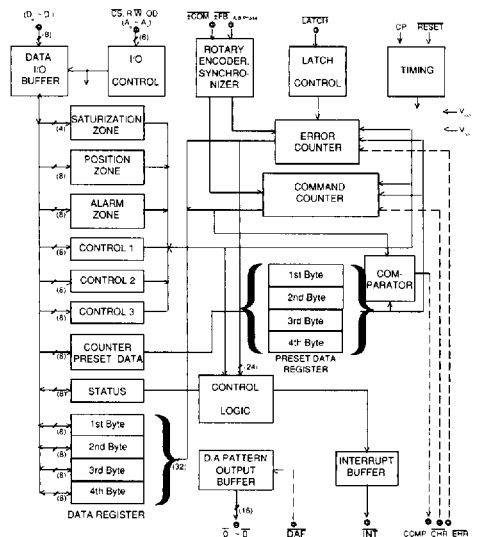

#### ORDERING INFORMATION

KM3702A □ □ □

Tape/Reel Code

Temp. Range

Package Code

**PACKAGE CODE**  
D: Plastic Dip  
Q: QFP

**TEMP. RANGE**  
C: -20 to +75 °C

**TAPE/REEL CODE**  
BX: Bulk/Bag  
MG: Magazine

# KM3702AD/AQ

## ABSOLUTE MAXIMUM RATINGS

Input Voltage .....  $V_{SS} - 0.3$  to  $V_{DD} + 0.3$  V  
 Supply Voltage .....  $V_{SS} - 0.3$  to  $V_{DD} + 7.0$  V  
 Power Dissipation (KM3702AD) ..... 1.25 W  
 Power Dissipation (KM3702AQ) ..... 1.00 W

Storage Temperature Range ..... -65 to +150 °C  
 Operating Temperature Range ..... -20 to +75 °C  
 Lead Soldering Temp. (10 sec.) ..... 300 °C

## ELECTRICAL CHARACTERISTICS

### D. C. CHARACTERISTICS

Test conditions:  $V_{SS} = 0$  V,  $T_A = -20$  to +75 °C

SYMBOL	PARAMETER	TEST CONDITIONS	MIN	TYP	MAX	UNITS
$V_{DD}$	Supply Voltage		4.75	5.0	5.25	V
$I_{DD}$	Supply Current				5.0	mA
<b>Input Signal 1 (Note 1)</b>						
$V_{IL}$	Low Level Input Voltage		0.0		0.6	V
$V_{IH}$	High Level Input Voltage		3.0		$V_{DD}$	V
$I_{LEAK}$	Input Leak Current				±10	µA
<b>Output Signal 2 (Note 2)</b>						
$I_{IL}$	Low Level Input Current	$V_{IL} = 0$ V	-200		-10	µA
$I_{IH}$	High Level Input Current	$V_{IH} = V_{DD}$			±10	µA
<b>Output Signal 3 (Note 3)</b>						
$V_{OL1}$	Low Level Output Voltage	$I_{OL1} = 2.0$ mA			0.4	V
$V_{OH1}$	High Level Output Voltage	$I_{OH1} = -200$ µA	2.4			V
<b>Output Signal 4 (Note 4)</b>						
$V_{OL2}$	Low Level Output Voltage	$I_{OL2} = 5.0$ mA			0.4	V
$V_{OH2}$	High Level Output Voltage	$I_{OH2} = -500$ µA	2.4			V
$I_{OFF2}$	High Impedance Output Voltage				±10	µA

Note 1: CS, R/W, OD, A<sub>2</sub>, A<sub>1</sub>, A<sub>0</sub>, LATCH, +COM, -COM, +FB, -FB, RESET, CP

Note 2: D<sub>7</sub>, D<sub>6</sub>, D<sub>5</sub>, D<sub>4</sub>, D<sub>3</sub>, D<sub>2</sub>, D<sub>1</sub>, D<sub>0</sub>, CHR, EHR, DAF

Note 3: INT, CCMP

Note 4: D<sub>7</sub>, D<sub>6</sub>, D<sub>5</sub>, D<sub>4</sub>, D<sub>3</sub>, D<sub>2</sub>, D<sub>1</sub>, D<sub>0</sub>

Note 5: O<sub>15</sub>, O<sub>14</sub>, O<sub>13</sub>, O<sub>12</sub>, O<sub>11</sub>, O<sub>10</sub>, O<sub>9</sub>, O<sub>8</sub>, O<sub>7</sub>, O<sub>6</sub>, O<sub>5</sub>, O<sub>4</sub>, O<sub>3</sub>, O<sub>2</sub>, O<sub>1</sub>, O<sub>0</sub>

**ELECTRICAL CHARACTERISTICS (CONT.)****A. C. CHARACTERISTICS**Test conditions:  $V_{DD} = 5\text{ V} \pm 5\%$ ,  $T_A = -20$  to  $+75\text{ }^\circ\text{C}$ 

SYMBOL	PARAMETER	TEST CONDITIONS	MIN	TYP	MAX	UNITS
<b>Output Signal 5 (Note 5)</b>						
$V_{OL3}$	Low Level Output Voltage	$I_{OL3} = 2.0\text{ mA}$			0.4	V
$V_{OH3}$	High Level Output Voltage	$I_{OH3} = -200\text{ }\mu\text{A}$	2.4			V
$I_{OFF3}$	High Impedance Output Voltage				$\pm 10$	$\mu\text{A}$
<b>CLOCKED SIGNAL 1 (Note 2)</b>						
$T_{CYC}$	Clock Pulse Period		0.1		10	$\mu\text{S}$
$T_W$	Clock Pulse Width		30		$T_{CYC} - 30$	ns
$T_{CR}$	Clock Pulse Rise Time				30	ns
$T_{CF}$	Clock Pulse Fall Time				30	ns
<b>INPUT SIGNAL 2 (Note 3)</b>						
$T_H$	Data Hold Time For Input		10			ns
$T_{SU}$	Data Set Up Time For Input		$T_W + 20$			ns
$t_{DAF}$	DAF To OUTPUT <sup>(-5)</sup>				50	ns
<b>OUTPUT SIGNAL 3 (Note 4)</b>						
$T_{D1}$	Output Delay Time 1	$C_L = 60\text{ pF}$			25	ns
$T_{D0}$	Output Delay Time 2	$C_L = 60\text{ pF}$			50	ns
<b>CPU INTERFACE 4 (Note 5)</b>						
$t_A$	Access Time	$C_L = 100\text{ pF}$			120	ns
$T_{CO}$	CS To Output	$C_L = 100\text{ pF}$			100	ns
$T_{OD}$	OD To Output	$C_L = 100\text{ pF}$			100	ns
$T_{OW}$	Width Of OD		120			ns
$T_{RDH}$	Data Hold Time After OD		0			ns

Note 2: CS, R/W, OD, A<sub>2</sub>, A<sub>1</sub>, A<sub>0</sub>, LATCH, +COM, -COM, +FB, -FB, RESET, CPNote 3: D<sub>7</sub>, D<sub>6</sub>, D<sub>5</sub>, D<sub>4</sub>, D<sub>3</sub>, D<sub>2</sub>, D<sub>1</sub>, D<sub>0</sub>, CHR, EHR, DAF

Note 4: INT, CCMP

Note 5: D<sub>7</sub>, D<sub>6</sub>, D<sub>5</sub>, D<sub>4</sub>, D<sub>3</sub>, D<sub>2</sub>, D<sub>1</sub>, D<sub>0</sub>Note 6: O<sub>15</sub>, O<sub>14</sub>, O<sub>13</sub>, O<sub>12</sub>, O<sub>11</sub>, O<sub>10</sub>, O<sub>9</sub>, O<sub>8</sub>, O<sub>7</sub>, O<sub>6</sub>, O<sub>5</sub>, O<sub>4</sub>, O<sub>3</sub>, O<sub>2</sub>, O<sub>1</sub>, O<sub>0</sub>

# KM3702AD/AQ

## ELECTRICAL CHARACTERISTICS (CONT.)

### A. C. CHARACTERISTICS

Test conditions:  $V_{DD} = 5\text{ V} \pm 5\%$ ,  $T_A = -20$  to  $+75\text{ }^\circ\text{C}$

SYMBOL	PARAMETER	TEST CONDITIONS	MIN	TYP	MAX	UNITS
<b>CPU INTERFACE 4 (Note 5)</b>						
$t_{CA}$	Address Valid After CONTROL		0			ns
$t_{AC}$	Address Valid Before CONTROL		40			ns
$t_{CH}$	CS Hold After CONTROL		0			ns
$t_{CSC}$	CS Valid Before Control		0			ns
$t_{CW}$	CS To WRITE		100			ns
$t_{CC}$	Width of R/W		100			ns
$t_{WDS}$	Data Set Up Time		120			ns
$t_{WDH}$	Data Hold Time After R/W		0			ns

Note 5:  $D_7, D_6, D_5, D_4, D_3, D_2, D_1, D_0$

### PIN FUNCTION (KM3702AD)

SIGNAL	SYMBOL	PIN NO.	I/O	DESCRIPTION
Power Supply	$V_{DD}$	40	--	+5V $\pm$ 5%
Ground	$V_{SS}$	20	--	Ground
Chip Select	CS	1	I	Device select signal
Write	R/W	2	I	Write control signal
Output Disable	OD	3	I	Output disable signal
Address	$A_2 \sim A_0$	4~6	I	Address select signal
Data	$D_7 \sim D_0$	7~14	I/O	Read/Write data I/O common 3-state I/O
Error Counter Latch	LATCH	15	I	If more than 3 clock pulses then, ERROR COUNTER value are transferred to the DATA REGISTER.
+Command	+COM	16	I	+Command pulse
-Command	-COM	17	I	-Command pulse
+Feedback	+FB	18	I	+Feedback pulse
-Feedback	-FB	19	I	-Feedback pulse
Reset	RESET	21	I	Reset signal
Clock Pulse	CP	22	I	System clock
Interrupt	INT	23	O	CPU interrupt signal
Output for D/A Converter	$0_0 \sim 0_{15}$	24~39	O	Output pattern for D/A converter 3-state output

## PIN FUNCTION (KM3702AQ)

NAME	SYMBOL	PIN NO.	I/O	DESCRIPTION
Power Supply	V <sub>DD</sub>	23, 53	-	+5 V ± 5%
Power Supply	V <sub>SS</sub>	2,8,31,38,46	-	GND
Chip Select	CS	49	I	Device Select Signal
Write	RW	50	I	Write Signal
Output Disable	OD	51	I	Read Signal
Address	A <sub>2</sub> -A <sub>6</sub>	55 TO 57	I	Address Signal
Data	D <sub>7</sub> to D <sub>6</sub>	1, 3 to 6, 58 to 60	I/O	Read/Write Data, I/O Common 3 State I/O
Error Counter Latch	LATCH	11	I	If more than 3 clock pulses than, Error Counter Value are transferred to the data register
+ Command	+ COM	18	I	+ Command Pulse
- Command	- COM	10	I	- Command Pulse
+ Feedback	+FB	20	I	+ Feedback Pulse
- Feedback	-FB	21	I	- Feedback Pulse
Reset	RESET	10	I	Reset Signal
Clock Pulse	CP	9	I	Basic Clock
Interrupt	INT	48	O	CPU Interrupt Error Counter
Output for D/A Converter	O <sub>8</sub> to O <sub>15</sub>	25 to 30, 32 to 37, 40 to 43	O	D/A Converter Output
Command Counter Reset	CHR	12	I	Command Counter Reset Signal
Error Counter Reset	EHR	13	I	Error Counter Reset Signal
D/A Converter for Output Floating	DAF	22	I	D/A Converter Output Floating
Command Counter Comparator Output	CCMP	47	O	Command Counter Data Over Preset Data Signal

# KM3702AD/AQ

## APPLICATIONS

1. Control of 2 axes can be accomplished by using one KM3701AD and two KM3702AD/AQs.

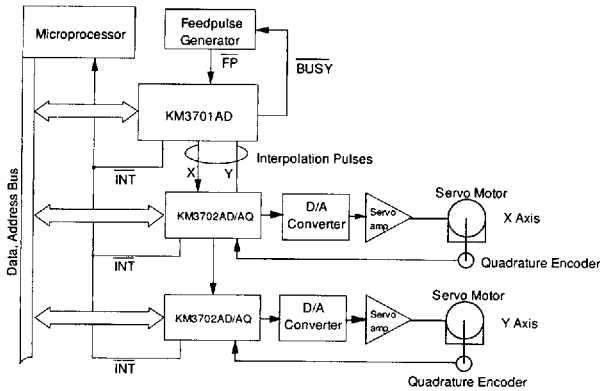

1. One KM3701AD can control two stepper motors.

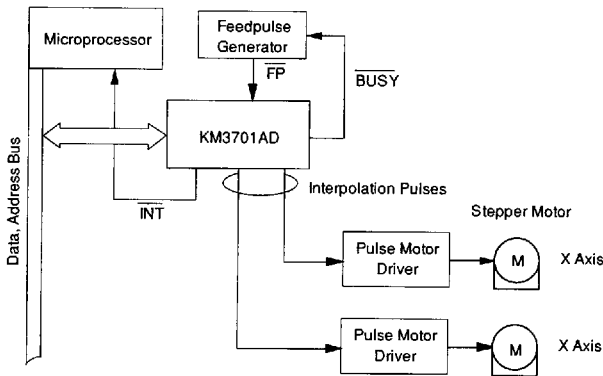

## INTERPOLATION

The interpolation pulse distribution rate is in accordance with the rate of the clock pulse (CP) and the internal calculation time. The internal calculation requires 11 clocks in the case of linear interpolation and 21 clocks in the case of circular or other interpolations.

Interpolation	Interpolation Pulse Distribution Rate
Linear interpolation	454.4KPPs
Circular or other	238.1KPPs