

FEATURES

Gain set with 2 external resistors

Gain range: 1 to 1000

Input voltage goes below ground

Very wide power supply range

Single supply: 2.7V to 36V

Dual supply: +/-2.7V to +/-18V

Bandwidth (G=100): 2.5 kHz

Input noise: 50 nV/ $\sqrt{\text{Hz}}$

Max supply current: 90 μA

Max offset voltage: 200 μV

Max differential input voltage: 1V

Min CMRR: 100 dB

MSOP-8 package

APPLICATIONS

Bridge amplifiers

Pressure Measurement

Medical instrumentation

Portable data acquisition

Multichannel systems

GENERAL DESCRIPTION

The AD8420 is a low cost, wide supply range amplifier that uses two resistors to set any gain between 1 and 1000. It is optimized to amplify small differential voltages in the presence of large common mode signals.

The AD8420 is based on a current mode architecture that gives it excellent input common mode range. Unlike conventional instrumentation amplifiers, the AD8420 can easily amplify signals at or even slightly below ground without requiring dual supplies. The AD8420 has a full rail to rail output, and the output voltage is completely independent of the input common mode voltage.

PIN CONFIGURATION

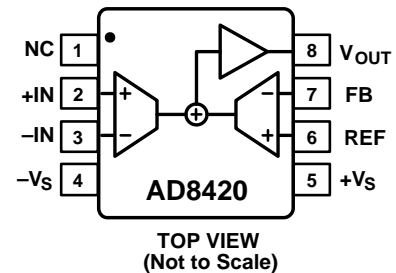

Figure 1.

Table 1. Instrumentation Amplifiers by Category¹

General Purpose	Zero Drift	Military Grade	Low Power	Digital Gain
AD8221/2	AD8231	AD620	AD8420	AD8250
AD8220/4	AD8290	AD621	AD8235/6	AD8251
AD8228	AD8293	AD524	AD627	AD8253
AD8295	AD8553	AD526	AD8226/7	AD8231
	AD8556	AD624	AD623	
	AD8557		AD8223	

¹ See www.analog.com for the latest instrumentation amplifiers.

The AD8420 can operate off both single or dual supplies. It works well for a portable system with a limited single supply voltage and equally well for a system using large dual supplies.

Gain is set using the ratio of two resistors. A reference pin allows the user to offset the output voltage. This feature is useful when the output signal needs to be centered around a specific voltage, such as mid-supply.

The AD8420 is available in an 8 pin MSOP package. Performance is specified over the full temperature range of -40°C to $+85^{\circ}\text{C}$. Part is operational from -40°C to $+125^{\circ}\text{C}$.

Rev. PrD

Information furnished by Analog Devices is believed to be accurate and reliable. However, no responsibility is assumed by Analog Devices for its use, nor for any infringements of patents or other rights of third parties that may result from its use. Specifications subject to change without notice. No license is granted by implication or otherwise under any patent or patent rights of Analog Devices. Trademarks and registered trademarks are the property of their respective owners.

SPECIFICATIONS

+V_S = +5V, -V_S = 0V, V_{REF} = 0 V, V_{IN+} = 0V, V_{IN-} = 0V, T_A = 25°C, G = 1 to 1000, R_L = 20 kΩ, specifications referred to input, unless otherwise noted

Table 2.

Parameter	Conditions	Min	Typ	Max	Unit
COMMON-MODE REJECTION RATIO (CMRR) CMRR DC to 60 Hz CMRR at 1 kHz	V _{CM} = 0 V to 2.7 V	100			dB dB
NOISE Voltage Noise Spectral Density Peak to Peak Current Noise Spectral Density Peak to Peak	f = 1 kHz, V _{DIFF} ≤ 100 mV f = 0.1 Hz to 10 Hz, V _{DIFF} ≤ 100 mV f = 1 kHz f = 0.1 Hz to 10 Hz		50 1.5		nV/√Hz μV p-p fA/√Hz pA p-p
VOLTAGE OFFSET Offset Average Temperature Coefficient Offset RTI vs. Supply (PSR)	T _A = -40°C to +85°C			200 1	μV μV/°C dB
INPUTS Input Bias Current ¹ Average Temperature Coefficient Input Offset Current Average Temperature Coefficient Input Impedance Differential Common Mode Differential Input Operating Voltage Input Operating Voltage (+IN, -IN, or REF)	Valid for REF & FB pair, as well as +IN & -IN T _A = +25°C T _A = +85°C T _A = -40°C T _A = -40°C to +85°C T _A = +25°C T _A = +85°C T _A = -40°C T _A = -40°C to +85°C T _A = -40°C to +85°C T _A = +25°C T _A = +85°C T _A = -40°C		25 1 130 2 1000 2	40 1 1	nA nA nA pA/°C nA nA nA pA/°C MΩ pF MΩ pF V V V V
DYNAMIC RESPONSE Small Signal -3 dB Bandwidth G = 1 G = 10 G = 100 G = 1000 Settling Time 0.01% G = 10 G = 100 G = 1000 Slew Rate	4 V step		250 25 2.5 0.25		kHz kHz kHz kHz μs μs μs V/μs
			Exceeds Bandwidth Limit		

GAIN²		$G = 1 + (R2/R1)$		
Gain Range		1	1000	V/V
Gain Error	$V_{OUT} = 0.2V \text{ to } 4.8V$		0.05	%
Gain vs. Temperature	$T_A = -40^\circ C \text{ to } +85^\circ C$		10	ppm/°C
OUTPUT				
Output Swing				
$R_L = 10 \text{ k}\Omega \text{ to mid supply}$	$T_A = +25^\circ C$	$-V_S + 0.15$	$+V_S - 0.15$	V
	$T_A = +85^\circ C$			V
	$T_A = -40^\circ C$			V
$R_L = 100 \text{ k}\Omega \text{ to mid supply}$	$T_A = +25^\circ C$	$-V_S + 0.1$	$+V_S - 0.1$	V
	$T_A = +85^\circ C$			V
	$T_A = -40^\circ C$			V
Short-Circuit Current			10	mA
POWER SUPPLY				
Operating Range	Single supply operation ³	2.7	36	V
Quiescent Current	$T_A = +25^\circ C$		75	μA
	$T_A = -40^\circ C$		90	μA
	$T_A = +85^\circ C$			μA
	$T_A = +85^\circ C$		100	μA
TEMPERATURE RANGE				
Specified		-40	+85	°C
Operational ⁴		-40	+125	°C

¹ The input stage uses pnp transistors, so input bias current always flows out of the part.

² For $G > 1$, errors from external resistors R1 and R2 should be added to these specifications, including error from FB pin bias current.

³ Minimum supply voltage indicated for V_{+IN} , V_{-IN} , $V_{REF} = 0V$.

⁴ See Typical Performance Curves for operation between $85^\circ C$ and $125^\circ C$

$+V_S = +15\text{ V}$, $-V_S = -15\text{ V}$, $V_{REF} = 0\text{ V}$, $T_A = 25^\circ\text{C}$, $G = 1$ to 1000 , $R_L = 20\text{ k}\Omega$, specifications referred to input, unless otherwise noted

Table 3.

Parameter	Conditions	Min	Typ	Max	Unit
COMMON-MODE REJECTION RATIO (CMRR) CMRR DC to 60 Hz CMRR at 1 kHz	$V_{CM} = -10\text{ V to }+10\text{ V}$	100			dB dB
NOISE					
Voltage Noise					
Spectral Density	$f = 1\text{ kHz}$, $V_{DIFF} \leq 100\text{ mV}$		50		nV/ $\sqrt{\text{Hz}}$
Peak to Peak	$f = 0.1\text{ Hz to }10\text{ Hz}$, $V_{DIFF} \leq 100\text{ mV}$		1.5		$\mu\text{V p-p}$
Current Noise					
Spectral Density	$f = 1\text{ kHz}$				fA/ $\sqrt{\text{Hz}}$
Peak to Peak	$f = 0.1\text{ Hz to }10\text{ Hz}$				pA p-p
VOLTAGE OFFSET					
Offset	$V_S = \pm 5\text{ V to } \pm 15\text{ V}$			200	μV
Average Temperature Coefficient	$T_A = -40^\circ\text{C to }+85^\circ\text{C}$			1	$\mu\text{V}/^\circ\text{C}$
Offset RTI vs. Supply (PSR)					dB
INPUTS					
Input Bias Current ¹	Valid for REF & FB pair, as well as +IN & -IN $T_A = +25^\circ\text{C}$ $T_A = +85^\circ\text{C}$ $T_A = -40^\circ\text{C}$		25	40	nA nA nA
Average Temperature Coefficient	$T_A = -40^\circ\text{C to }+85^\circ\text{C}$				pA/ $^\circ\text{C}$
Input Offset Current	$T_A = +25^\circ\text{C}$ $T_A = +85^\circ\text{C}$ $T_A = -40^\circ\text{C}$			1	nA nA nA
Average Temperature Coefficient	$T_A = -40^\circ\text{C to }+85^\circ\text{C}$				pA/ $^\circ\text{C}$
Input Impedance					
Differential			130 3		M Ω pF
Common Mode			1000 3		M Ω pF
Differential Input Operating Voltage	$T_A = -40^\circ\text{C to }+85^\circ\text{C}$	-1		1	V
Input Operating Voltage (+IN, -IN, or REF)	$T_A = +25^\circ\text{C}$ $T_A = +85^\circ\text{C}$ $T_A = -40^\circ\text{C}$	$-V_S - 0.15$ $-V_S - 0.05$ $-V_S - 0.2$		$+V_S - 2.2$ $+V_S - 1.8$ $+V_S - 2.7$	V V V
DYNAMIC RESPONSE					
Small Signal -3 dB Bandwidth	Check voltage differential				
G = 1			250		kHz
G = 10			25		kHz
G = 100			2.5		kHz
G = 1000			0.25		kHz
Settling Time 0.01%	10 V step				
G = 1					μs
G = 10					μs
G = 100					μs
G = 1000					μs
Slew Rate				Exceeds Bandwidth Limit	V/ μs

GAIN ²		$G = 1 + (R2/R1)$		
Gain Range		1	1000	V/V
Gain Error	$V_{OUT} \pm 10\text{ V}$		0.05	%
Gain Nonlinearity	$V_{OUT} = -10\text{ V to }+10\text{ V}$			
G = 1 to 10	$R_L \geq 20\text{ k}\Omega$			ppm
G = 100	$R_L \geq 20\text{ k}\Omega$			ppm
G = 1000	$R_L \geq 20\text{ k}\Omega$			ppm
Gain vs. Temperature	$T_A = -40^\circ\text{C to }+85^\circ\text{C}$		10	ppm/°C
OUTPUT				
Output Swing				
$R_L = 20\text{ k}\Omega$ to ground	$T_A = +25^\circ\text{C}$	$-V_S + 0.15$	$+V_S - 0.15$	V
	$T_A = +85^\circ\text{C}$			V
	$T_A = -40^\circ\text{C}$			V
$R_L = 100\text{ k}\Omega$ to ground	$T_A = +25^\circ\text{C}$	$-V_S + 0.1$	$+V_S - 0.1$	V
	$T_A = +85^\circ\text{C}$			V
	$T_A = -40^\circ\text{C}$			V
Short-Circuit Current			10	mA
POWER SUPPLY				
Operating Range	Dual supply operation ³	± 2.7	$\pm 18\text{ V}$	V
Quiescent Current	$T_A = +25^\circ\text{C}$	75	90	μA
	$T_A = -40^\circ\text{C}$			μA
	$T_A = +85^\circ\text{C}$	100		μA
TEMPERATURE RANGE				
Specified		-40	+85	°C
Operational ⁴		-40	+125	°C

¹ The input stage uses pnp transistors, so input bias current always flows out of the part.

² For $G > 1$, errors from external resistors R1 and R2 should be added to these specifications, including error from FB pin bias current

³ Minimum positive supply voltage indicated for V_{+IN} , V_{-IN} , $V_{REF} = 0\text{ V}$. With V_{+IN} , V_{-IN} , $V_{REF} = -V_S$, minimum supply is $\pm 1.35\text{ V}$.

⁴ See Typical Performance Curves for operation between 85°C and 125°C

ABSOLUTE MAXIMUM RATINGS

Table 4.

Parameter	Rating
Supply Voltage	± 18 V
Output Short-Circuit Current	Indefinite
Maximum Voltage at $-IN$ or $+IN$	$-V_s + 40$ V
Minimum Voltage at $-IN$ or $+IN$	$+V_s - 40$ V
Maximum Voltage at REF	$+V_s + 0.2$ V
Minimum Voltage at REF	$-V_s - 0.2$ V
Storage Temperature Range	-65°C to $+150^{\circ}\text{C}$
ESD	
Human Body Model	
Charge Device Model	
Machine Model	

Stresses above those listed under Absolute Maximum Ratings may cause permanent damage to the device. This is a stress rating only; functional operation of the device at these or any other conditions above those indicated in the operational section of this specification is not implied. Exposure to absolute maximum rating conditions for extended periods may affect device reliability.

THERMAL RESISTANCE

θ_{JA} is specified for a device in free air.

Table 5.

Package	θ_{JA}	Unit
8-Lead MSOP, 4-Layer JEDEC Board	135	$^{\circ}\text{C}/\text{W}$

ESD CAUTION



ESD (electrostatic discharge) sensitive device. Charged devices and circuit boards can discharge without detection. Although this product features patented or proprietary protection circuitry, damage may occur on devices subjected to high energy ESD. Therefore, proper ESD precautions should be taken to avoid performance degradation or loss of functionality.

PIN CONFIGURATION AND FUNCTION DESCRIPTIONS

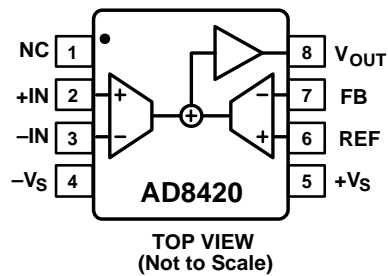

Figure 2. Pin Configuration

Table 6. Pin Function Descriptions

Pin No.	Mnemonic	Description
1	NC	This pin not connected internally. For best CMRR vs. frequency and leakage performance, connect this pin to negative supply.
2	+IN	Positive Input.
3	-IN	Negative Input
4	-Vs	Negative Supply.
5	+Vs	Positive Supply.
6	REF	Reference.
7	FB	Feedback.
8	V _{OUT}	Output.

THEORY OF OPERATION

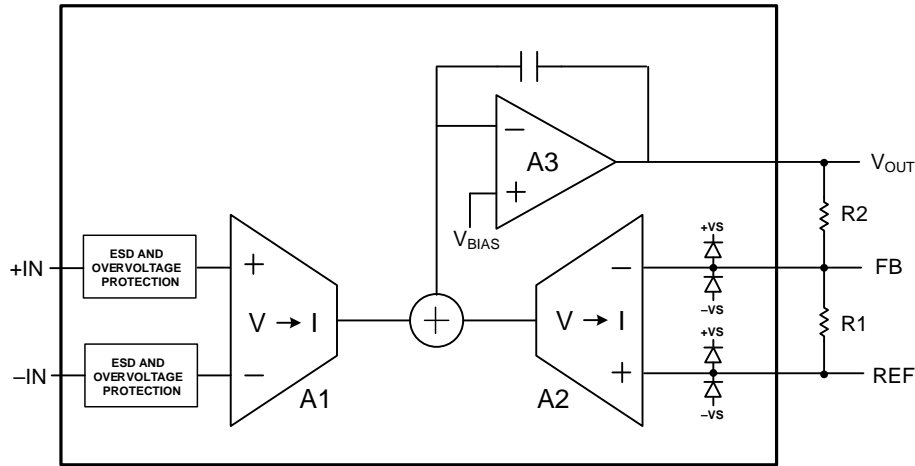

Figure 3. Simplified Schematic

ARCHITECTURE

The AD8420 consists of three amplifiers: two matched transconductance amplifiers that convert voltage to current and one integrator amplifier that converts current to voltage.

The AD8420 works as follows: assume a differential voltage is applied across inputs +IN and -IN. This input voltage is converted into a current by Amplifier A1. This will create a difference in current between A1 and A2, which is fed into A3. A3's output voltage will change until A2 sinks all the current A1 is generating. Because the gain of A1 and A2 are matched, this means the differential input voltage across A1 will appear across the inputs of A2. Gain is set by the ratio of R2 to R1.

Because the AD8420 converts the input differential signals to a current, there are no internal headroom issues as with traditional instrumentation amplifier architectures. This is particularly important when amplifying a signal with a common mode voltage near one of the supply rails.

To improve robustness and ease of use, the AD8420 includes overvoltage protection on its inputs. This protection scheme allows input voltages well beyond the supply rails (as well as wide differential input voltages) without damaging the part.

SETTING THE GAIN

The transfer function of the AD8420 is

$$V_{OUT} = G(V_{IN+} - V_{IN-}) + V_{REF}$$

where:

$$G = 1 + \frac{R2}{R1}$$

Table 7. Suggested Resistors for Various Gains - 1% Resistors

R1 (kΩ)	R2 (kΩ)	Gain
none	short	1.00
49.9	49.9	2.00
20	80.6	5.03
10	90.9	10.09
5	95.3	20.06
2	97.6	49.8
1	100	101
1	200	201
1	499	500
1	1000	1001

While the ratio of R2 to R1 sets the gain, the absolute value of the resistors is up to the designer. Larger values reduce power consumption and output loading; smaller values limit FB input bias current error.

A method that allows large value feedback resistors while limiting FB bias current error is to place a resistor of value $R1 \parallel R2$ in series with the REF terminal as shown in Figure 4. At higher gains, this resistor can simply be the same value as R1.

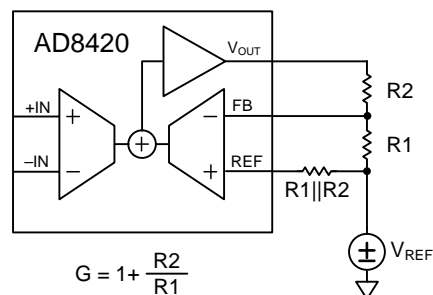

Figure 4. Cancelling Out Error from FB Input Bias Current

INPUT VOLTAGE RANGE

Unlike traditional instrumentation amplifier architectures, the allowed input range of the AD8420 is simplicity itself. For the AD8420’s transfer function to be valid, the input voltage should follow two rules:

- 1) Keep differential input voltage within ±1V.
- 2) Keep voltage on +IN, -IN, and REF pins in specified input voltage range

No hexagonal figures. No complicated formulas.

INPUT PROTECTION

The AD8420 has very robust inputs and typically does not need additional input protection. Input voltages can be up to 40 V from the opposite supply rail. For example, with a +5 V positive supply and a -8 V negative supply, the part can safely withstand voltages from -35 V to 32 V. The part can handle large differential input voltages, even when the part is in high gain, without damage.

The rest of the AD8420 terminals should be kept within the supplies. All terminals of the AD8426 are protected against ESD.

For applications that require protection beyond the AD8420’s limits, place diodes at the AD8420 inputs to limit voltage and resistors in series with the inputs to limit the current into these diodes. To keep input bias current at minimum, low leakage diode clamps such as the BAV199 should be used. The AD8420 also combines well with TVS diodes such as the PTVSxS1UR.

DRIVING THE REFERENCE PIN

Traditional instrumentation amplifier architectures require the reference pin to be driven with a low impedance source. In traditional architectures, impedance at the reference pin degrades both CMRR and gain accuracy. With the AD8420 architecture, resistance at the reference pin has no effect on CMRR.

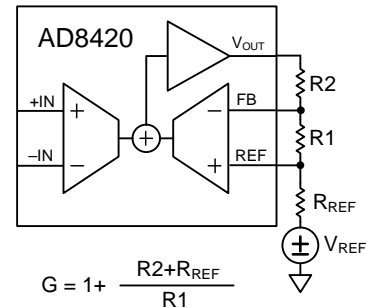

Figure 5. Calculating Gain with Reference Resistance

Resistance at the reference pin does affect the AD8420’s gain, but if this resistance is constant, the gain setting resistors can be adjusted to compensate. For example, the AD8420 can be driven with a voltage divider as shown in Figure 6.

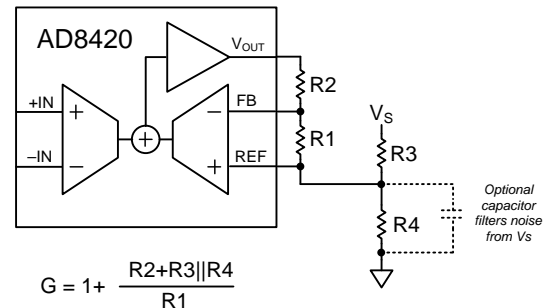
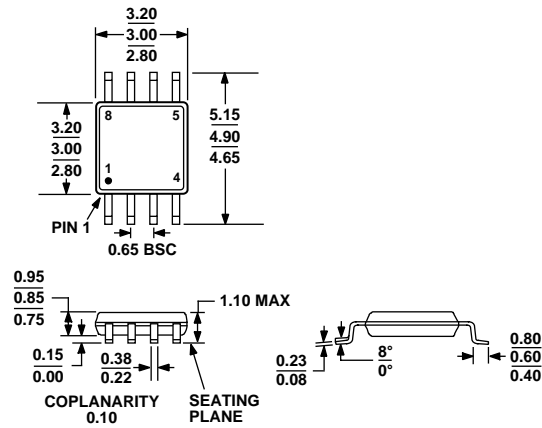

Figure 6. Using Resistor Divider to Set Reference Voltage

OUTLINE DIMENSIONS



COMPLIANT TO JEDEC STANDARDS MO-187-AA

Figure 7. 8-Lead Mini Small Outline Package [MSOP] (RM-8)

Dimensions shown in millimeters

ORDERING GUIDE

Model ¹	Temperature Range	Package Description	Package	Branding
AD8420ARMZ	-40°C to +125°C	Standard grade, tube	MSOP	Y3Y
AD8420ARMZ-R7	-40°C to +125°C	Standard grade, 7 inch Tape and Reel	MSOP	Y3Y
AD8420ARMZ-RL	-40°C to +125°C	Standard grade, 13 inch Tape and Reel	MSOP	Y3Y
AD8420BRMZ	-40°C to +125°C	High performance grade, tube	MSOP	Y3Z
AD8420BRMZ-R7	-40°C to +125°C	High performance grade, 7 inch Tape and Reel	MSOP	Y3Z
AD8420BRMZ-RL	-40°C to +125°C	High performance grade, 13 inch Tape and Reel	MSOP	Y3Z

¹ Z = RoHS Compliant Part.