

# PRELIMINARY

Notice ; This is not a final specification.  
some parametric limits are subject to change.

MITSUBISHI SOUND PROCESSOR ICs

# M61508FP

THE ELECTRIC VOLUME of BUILD-IN NON FADER VOLUME with TONE CONTROL

## APPLICATION

- This IC can be used Analog Signal processing of Power Amp.front stage
- This IC can be used Car Audio System,Home Audio System and TV.

## FEATURES

- This IC is unnecessary for outside putting CR by using SCF for Loudness and Tone Control.  
Bass : +16dB to -12dB/2dBstep.  $f_0, Q$ =variable.  $f_0=50\text{Hz}, 80\text{Hz}, 120\text{Hz}$   $Q=1, 1.25, 1.5, 2$   
Mid : +12dB to -12dB/2dBstep.  $f_0, Q$ =variable.  $f_0=700\text{Hz}, 1\text{KHz}, 2\text{KHz}, 10\text{KHz}$   $Q=1.5, 2$   
Treble : +12dB to -12dB/2dBstep.  $f_0$ =variable.  $f_0=8\text{KHz}, 12\text{KHz}$   
Loudness :  $f_0$ =variable.  $f_0=60\text{Hz}, 80\text{Hz}, 100\text{Hz}$
- Build-in Non Fader Volume  
+12dB to -12dB /2dB step,  $-\infty$  dB
- Build-in Zero-Crossing Detector Circuit for Changing Noise Measure.
- Build-in Differential Input and Differential Output
- Build-in Input Selector (4 input + Differential Input)
- Build-in Input Gain Control  
0dB to +18.75dB/1.25dB step
- Build-in Master Volume and Fader Volume (Front,Rear)  
Volume : 0dB to -83dB ,  $-\infty$  dB/1dB step  
Fader : 0dB , -1dB,-2dB,-3dB,-4dB,-6dB,-8dB,-12dB,-16dB,-20dB,-30dB,-45dB,-60dB, $-\infty$  dB/16 step
- Serial Data Control of 2 lines formula.

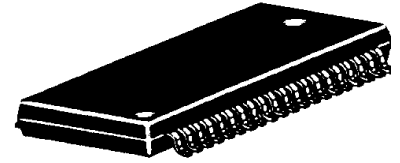

Outline  
36P2R

## RECOMMENDED OPERATING CONDITIONS

Supply voltage range... VCC=7V to 9V  
VDD=4.5V to 5.5V

Rated supply voltage... VCC=8V  
VDD=5V

## SYSTEM BLOCK DIAGRAM

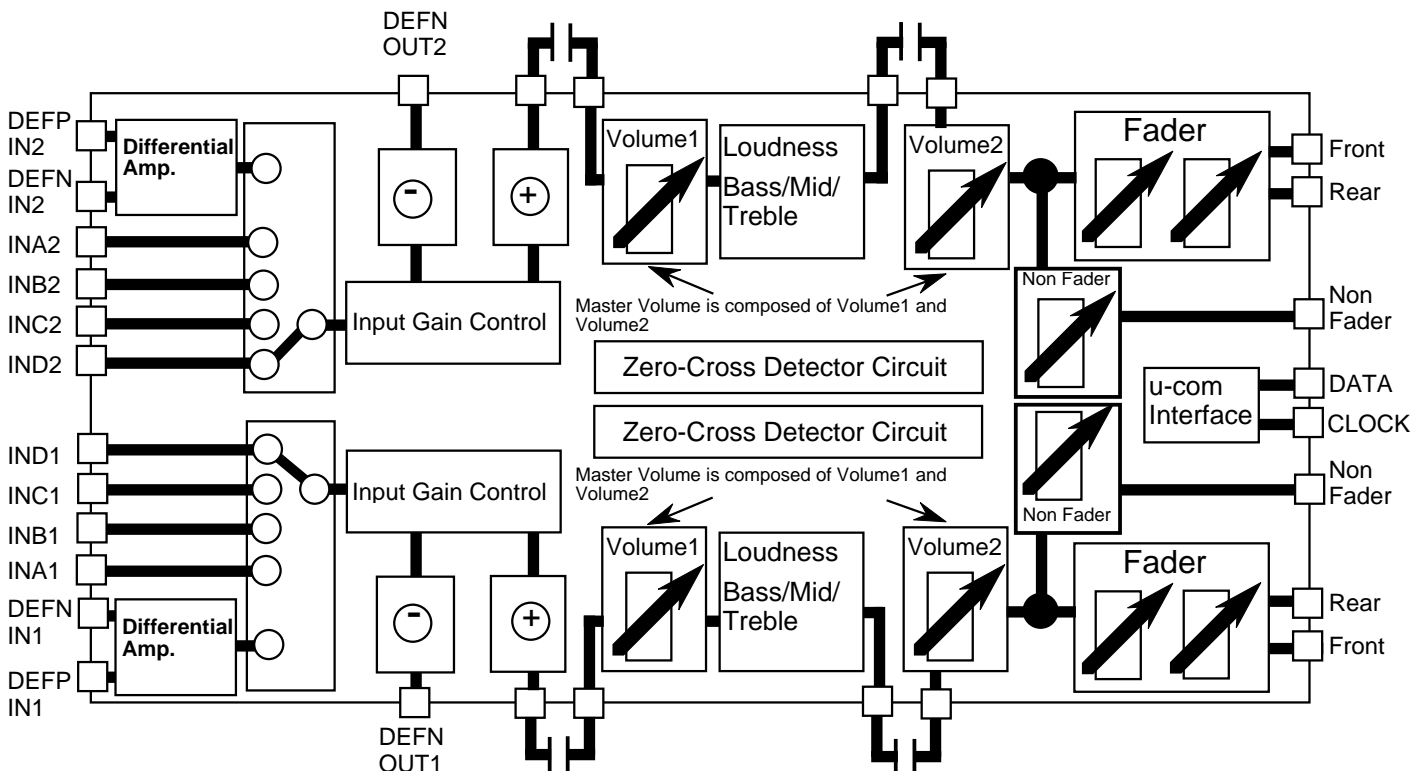

THE ELECTRIC VOLUME of BUILD-IN NON FADER VOLUME with TONE CONTROL

IC Internal Block Diagram

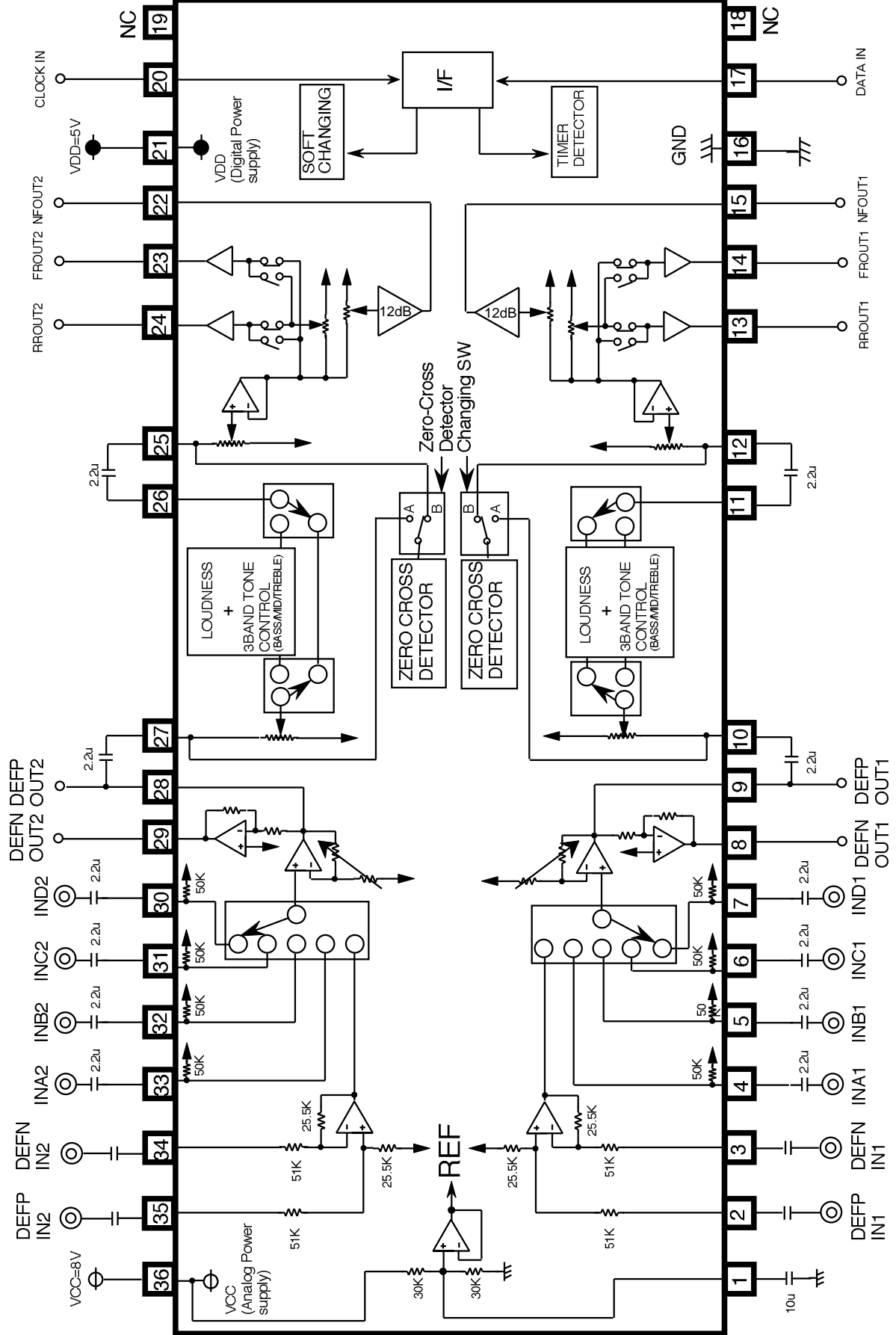

**THE ELECTRIC VOLUME of BUILD-IN NON FADER VOLUME with TONE CONTROL**

---

**PIN DESCRIPTION**

Pin No.	Symbol	Function
1	REF	Signal Ground of IC. Grounding about 10uF
2	DEFP IN1	Positive Input pin of Differential Amp.
3	DEFN IN1	Negative Input pin of Differential Amp.
4	INA1	Input pin of Channel 1 for Input Selector SW
5	INB1	
6	INC1	
7	IND1	
8	DEFN OUT1	Output pin (-) of Differential Amp.
9	SEL OUT1	Output pin of Input Selector
10	VOL IN1	Input pin of Volume1
11	TONE OUT1	Output pin of Tone
12	FADER IN1	Input pin of Volume2
13	REAR OUT1	Output pin of Fader Volume (rear)
14	FRONT OUT1	Output pin of Fader Volume (front)
15	Non Fader OUT1	Output pin of Non Fader Volume
16	GND	Ground Pin
17	DATA	Input pin of Control Data. It synchronized at CLOCK and inputted Data
18	N.C.	N.C. Pin

## THE ELECTRIC VOLUME of BUILD-IN NON FADER VOLUME with TONE CONTROL

Pin No.	System	Function
19	N.C.	N.C. Pin
20	CLOCK	Clock Input pin for Serial Data Transmission
21	VDD	Digital Power Supply pin
22	Non Fader OUT2	Output pin of Non Fader Volume
23	FRONT OUT2	Output pin of Fader Volume (front)
24	REAR OUT2	Output pin of Fader Volume (rear)
25	FADER IN2	Input pin of Volume 2
26	TONE OUT2	Output pin of Tone
27	VOL IN2	Input pin of Volume1
28	SEL OUT2	Output pin of Input Selector
29	DEFN OUT1	Output pin (-) of Differential Amp.
30	IND2	Input pin of channel 2 for Input Selector SW
31	INC2	
32	INB2	
33	INA2	
34	DEFN IN1	
35	DEFP IN1	Positive Input pin of Differential Amp.
36	VCC	Analog Power Supply pin

THE ELECTRIC VOLUME of BUILD-IN NON FADER VOLUME with TONE CONTROL

SIGNAL COMMUNICATION DIAGRAM (Channel 1 side only)

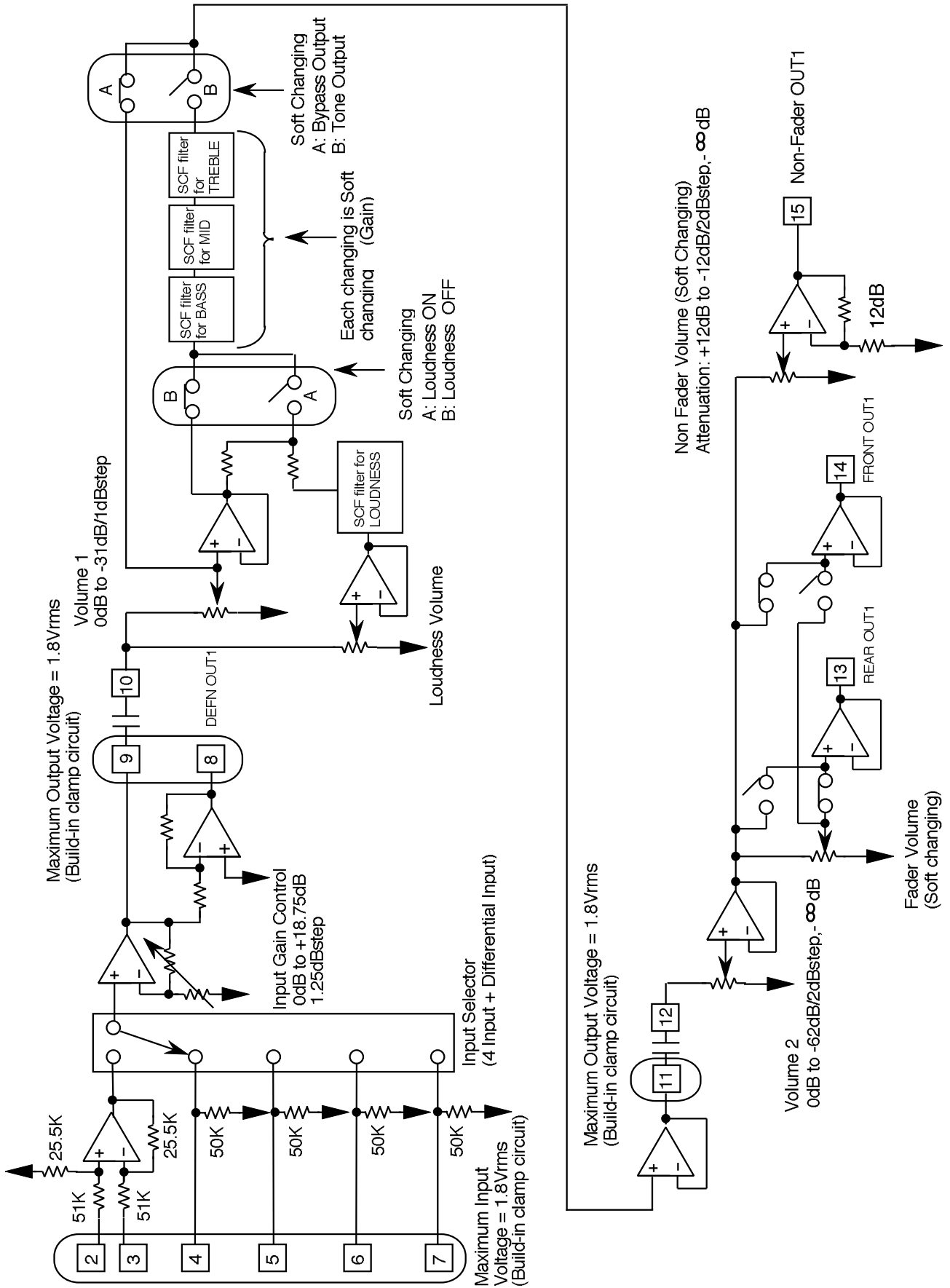

## THE ELECTRIC VOLUME of BUILD-IN NON FADER VOLUME with TONE CONTROL

**ELECTRICAL CHARACTERISTICS**

(Ta=25°C, VCC=8V, VDD=5V, Input Gain/Volume/Tone/fader=0dB, Loudness=OFF, unless otherwise noted.)

Symbol	Parameter	Test conditions	Limits			Unit
			Min	typ	Max	
I <sub>CC</sub>	Circuit Current	No signal setting			40	mA
G <sub>V</sub>	Pass Gain		-2	0	+2	dB
A <sub>TT(VOL)</sub>	Volume Maximum Attenuation Quantity	V <sub>i</sub> =1V <sub>rms</sub> , f=1KHz ATT(VOL)= -∞ dB	—	-90	-80	dB
Δ A <sub>TT(VOL)</sub>	Crosstalk between Channels	ATT(VOL)= 0dB	-2	0	+2	dB
V <sub>IM</sub>	Maximum Input Voltage	f=1KHz , DIN-AUDIO THD=1%	—	—	1.8	V <sub>rms</sub>
G(Bass)B	Boost Quantity (Bass)	f=100Hz	13	16	19	dB
G(Bass)C	Cut Quantity (Bass)	f=100Hz	-15	-12	-9	dB
G(MID)B	Boost Quantity (Mid)	f=1KHz	9	12	15	dB
G(MID)C	Cut Quantity (Mid)	f=1KHz	-15	-12	-9	dB
G(Tre)B	Boost Quantity (Treble)	f=10KHz	9	12	15	dB
G(Tre)C	Cut Quantity (Treble)	f=10KHz	-15	-12	-9	dB
A <sub>TT (FED)</sub>	Fader Maximum Attenuation Quantity	V <sub>i</sub> =1V <sub>rms</sub> , f=1KHz, DIN-AUDIO ATT(FED)= -∞ dB	—	-90	-80	dB
V <sub>OM</sub>	Maximum input voltage	f=1KHz , DIN-AUDIO THD=1%	1.8	—	—	V <sub>rms</sub>
V <sub>no 1</sub>	output noise voltage	R <sub>g</sub> =0, DIN-AUDIO		12		uV <sub>rms</sub>
V <sub>no 2</sub>		Bypass setting R <sub>g</sub> =0, DIN-AUDIO		5		
V <sub>no 3</sub>		ATT(VOL)= -∞ dB R <sub>g</sub> =0, DIN-AUDIO		3.5		
THD	Total harmonic distortion	f=1KHz, V <sub>o</sub> =0.5V <sub>rms</sub> BW:400Hz to 30KHz	—	0.01	0.05	%
CS	Channel Separation	f=1KHz, DIN-AUDIO	—	-90	-75	dB
CT	Input Selector Crosstalk	f=1KHz, DIN-AUDIO	—	-75	-60	dB
G <sub>V(LOUD)</sub>	Loudness voltage gain	Loudness ON , f=100Hz VOL1= -30dB , VOL2=0dB LOUD_VOL= -20dB	10	13	16	dB
G <sub>V(GAIN)</sub>	Input gain control	G <sub>V(GAIN)</sub> = +18.75dB	15.75	18.75	21.75	dB
CMRR	Common Mode Rejection Ratio	2,3pin/34,35pin Common mode signal input setting		50		dB

THE ELECTRIC VOLUME of BUILD-IN NON FADER VOLUME with TONE CONTROL

**CONNECTION of DATA AND CLOCK**

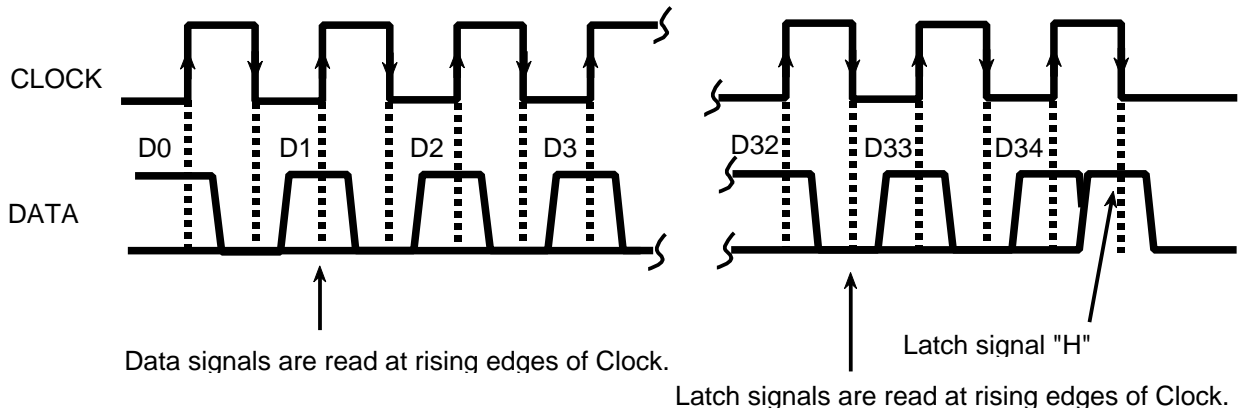

**DIGITAL BLOCK DIRECT CURRENT CHARACTERISTIC**

Symbol	Parameter	Test Conditions	Limits			Unit	
			Min	typ	Max		
$V_{IL}$	"L" Level Input Voltage	VDD=5V setting DATA,CLOCK Pin	0	~	1.0	V	
$V_{IH}$	"H" Level Input Voltage		4.0	~	5.0		
$I_{IL}$	"L" Level Input Electric Current	V=0V	DATA, CLOCK Pin	-10	-	10	u A
$I_{IH}$	"H" Level Input Electric Current	V=5V		-	-	10	

THE ELECTRIC VOLUME of BUILD-IN NON FADER VOLUME with TONE CONTROL

**CLOCK AND DATA TIMING**

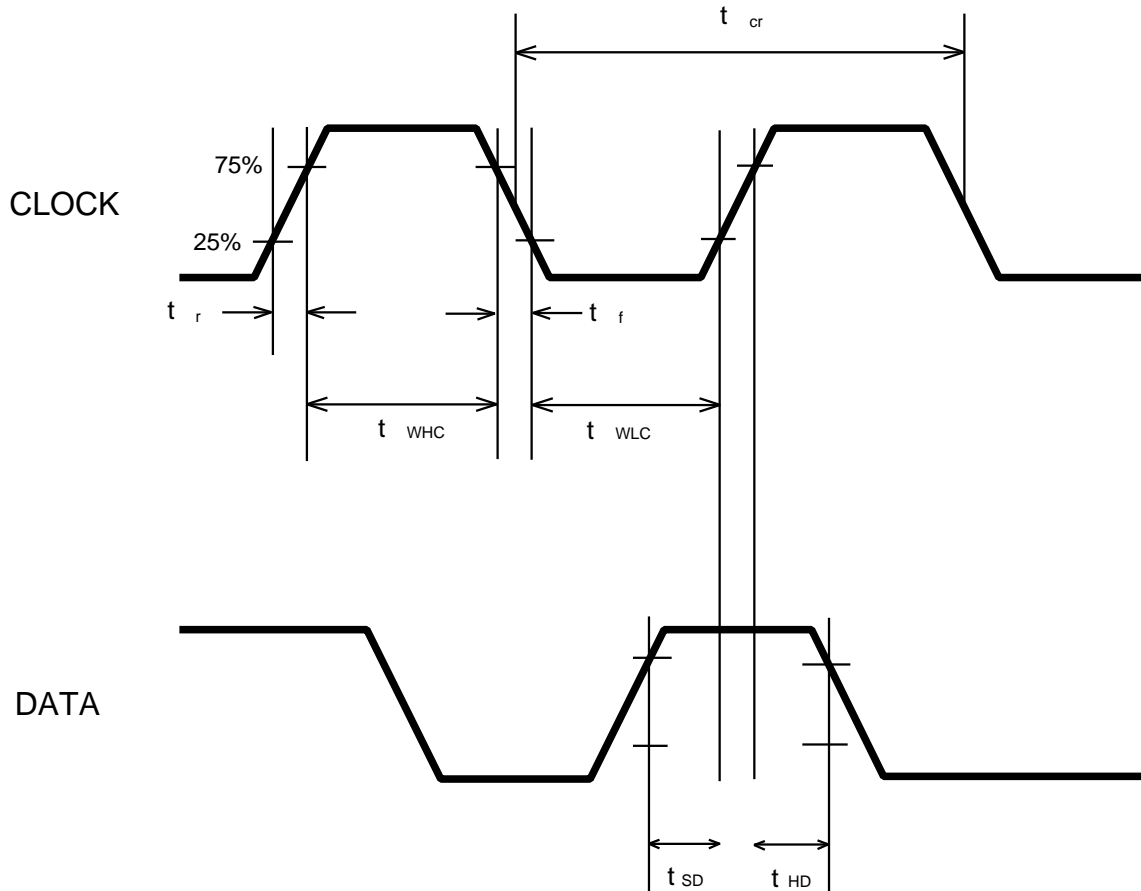

**DIGITAL BLOCK ALTERNATING CURRENT CHARACTERISTIC**

Symbol	Parameter	Limits			Unit
		Min	typ	Max	
$t_{cr}$	CLOCK Cycle Time	4	-	-	uS
$t_{WHC}$	CLOCK Pulse Width ("H" level)	1.6	-	-	
$t_{WLC}$	CLOCK Pulse Width ("L" level)	1.6	-	-	
$t_r$	CLOCK Rise Time	-	-	0.4	
$t_f$	CLOCK Fall Time	-	-	0.4	
$t_{SD}$	DATA Setup Time	0.8	-	-	
$t_{HD}$	DATA Hold Time	0.8	-	-	



THE ELECTRIC VOLUME of BUILD-IN NON FADER VOLUME with TONE CONTROL

**DATA INPUT FORMAT**

DATA SELECT (D33, D34)

- 00 : Volume 1 / Input Selector / Input Gain Control / Loudness Gain
- 01 : Volume 2
- 10 : Fader / Non Fader / Bass / Mid / Treble / Loudness ON/OFF

Data Transmission Direction →

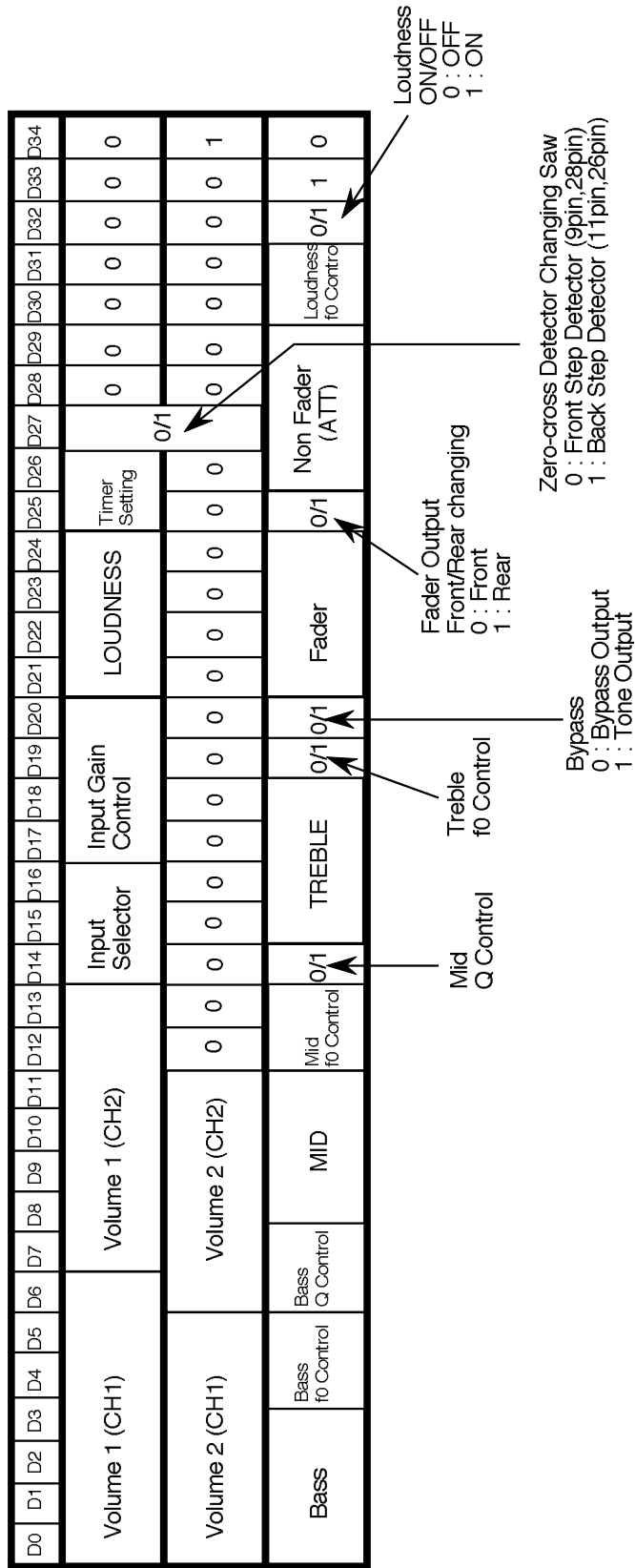

Note) Data transmission (Rewriting) of D33=1, D34=0 setting, put 100msec interval and data transmission

THE ELECTRIC VOLUME of BUILD-IN NON FADER VOLUME with TONE CONTROL

**VOLUME 1 CODE**

ATTVA1	CH1	D0	D1	D2	D3	D4
	CH2	D7	D8	D9	D10	D11
0dB	0	0	0	0	0	1
-1dB	1	1	1	1	1	0
-2dB	0	1	1	1	1	0
-3dB	1	0	1	1	1	0
-4dB	0	0	1	1	1	0
-5dB	1	1	0	1	1	0
-6dB	0	1	0	1	1	0
-7dB	1	0	0	1	1	0
-8dB	0	0	0	1	1	0
-9dB	1	1	1	0	0	0
-10dB	0	1	1	0	0	0
-11dB	1	0	1	0	0	0
-12dB	0	0	1	0	0	0
-16dB	1	1	0	0	0	0
-20dB	0	1	0	0	0	0
-24dB	1	0	0	0	0	0
-28dB	0	0	0	0	0	0

ATTVA2	CH1	D5	D6
	CH2	D12	D13
0dB	1	1	
-1dB	0	1	
-2dB	1	0	
-3dB	0	0	

( ATTVA2 fixed to 0dB when 0dB ~ -12dB setting. )

**VOLUME 2 CODE**

ATT VB1	CH1	D0	D1	D2	D3
	CH2	D6	D7	D8	D9
0dB	0	1	1	1	1
-2dB	1	0	1	1	1
-4dB	0	0	1	1	1
-6dB	1	1	0	1	1
-8dB	0	1	0	1	1
-10dB	1	0	0	1	1
-12dB	0	0	0	1	1
-14dB	1	1	1	0	0
-16dB	0	1	1	0	0
-24dB	1	0	1	0	0
-32dB	0	0	1	0	0
-40dB	1	1	0	0	0
-48dB	0	1	0	0	0
-56dB	1	0	0	0	0
-∞ dB	0	0	0	0	0

ATTVB2	CH1	D4	D5
	CH2	D10	D11
0dB	1	1	
-2dB	0	1	
-4dB	1	0	
-6dB	0	0	

( ATTVB2 fixed to 0dB when 0dB ~ -16dB setting. )

**TIMER SETTING CODE**

TIMER	D25	D26
5mS	1	1
10mS	0	1
15mS	1	0
20mS	0	0

# PRELIMINARY

Notice ; This is not a final specification.  
some parametric limits are subject to change.

# M61508FP

## THE ELECTRIC VOLUME of BUILD-IN NON FADER VOLUME with TONE CONTROL

### TONE CODE

MID	D8	D9	D10	D11
TREBLE	D15	D16	D17	D18
12dB	0	1	1	0
10dB	1	0	1	0
8dB	0	0	1	0
6dB	1	1	0	0
4dB	0	1	0	0
2dB	1	0	0	0
0dB	0	0	0	0/1
-2dB	1	0	0	1
-4dB	0	1	0	1
-6dB	1	1	0	1
-8dB	0	0	1	1
-10dB	1	0	1	1
-12dB	0	1	1	1

BASS	D0	D1	D2	D3
16dB	0	0	0	1
14dB	1	1	1	0
12dB	0	1	1	0
10dB	1	0	1	0
8dB	0	0	1	0
6dB	1	1	0	0
4dB	0	1	0	0
2dB	1	0	0	0
0dB	0	0	0	0
-2dB	1	0	0	1
-4dB	0	1	0	1
-6dB	1	1	0	1
-8dB	0	0	1	1
-10dB	1	0	1	1
-12dB	0	1	1	1

### LOUDNESS VOLUME CODE

LOUDNESS	D21	D22	D23	D24
-2dB	1	1	1	1
-4dB	0	1	1	1
-6dB	1	0	1	1
-8dB	0	0	1	1
-10dB	1	1	0	1
-12dB	0	1	0	1
-14dB	1	0	0	1
-16dB	0	0	0	1
-18dB	1	1	1	0
-20dB	0	1	1	0
-22dB	1	0	1	0
-24dB	0	0	1	0
-26dB	1	1	0	0
-28dB	0	1	0	0
-30dB	1	0	0	0
-∞ dB	0	0	0	0

\* Please refer to 21,22 page for Loudness gain setting.

### LOUDNESS f0 CONTROL

LOUDNESS f0 CONTROL	D30	D31
f0=60Hz	1	1
f0=80Hz	0	1
f0=100Hz	1	0

### TONE f0,Q CONTROL CODE

BASS f0 CONTROL	D4	D5
f0=50Hz	1	1
f0=80Hz	0	1
f0=120Hz	1	0

MID f0 CONTROL	D12	D13
f0=700Hz	1	1
f0=1KHz	0	1
f0=2KHz	1	0
f0=10KHz	0	0

TREBLE f0 CONTROL	D19
f0=8KHz	1
f0=12KHz	0

BASS Q CONTROL	D6	D7
Q=2	1	1
Q=1.5	0	1
Q=1.25	1	0
Q=1	0	0

MID Q CONTROL	D14
Q=1.5	1
Q=2	0

THE ELECTRIC VOLUME of BUILD-IN NON FADER VOLUME with TONE CONTROL

**SELECTOR CODE**

SELECTOR	D14	D15	D16
INA	0	0	1
INB	1	1	0
INC	0	1	0
IND	1	0	0
Differential Input	0	0	0

**NON FADER CODE**

ATT	D26	D27	D28	D29
+12dB	1	0	1	1
+10dB	0	0	1	1
+8dB	1	1	0	1
+6dB	0	1	0	1
+4dB	1	0	0	1
+2dB	0	0	0	1
0dB	1	1	1	0
-2dB	0	1	1	0
-4dB	1	0	1	0
-6dB	0	0	1	0
-8dB	1	1	0	0
-10dB	0	1	0	0
-12dB	1	0	0	0
-∞ dB	0	0	0	0

**INPUT GAIN CONTROL CODE**

INPUT GAIN CONTROL	D17	D18	D19	D20
0dB	1	1	1	1
1.25dB	0	1	1	1
2.50dB	1	0	1	1
3.75dB	0	0	1	1
5.00dB	1	1	0	1
6.25dB	0	1	0	1
7.50dB	1	0	0	1
8.75dB	0	0	0	1
10.00dB	1	1	1	0
11.25dB	0	1	1	0
12.50dB	1	0	1	0
13.75dB	0	0	1	0
15.00dB	1	1	0	0
16.25dB	0	1	0	0
17.50dB	1	0	0	0
18.75dB	0	0	0	0

**FADER CODE**

FADER	D21	D22	D23	D24
0dB	1	1	1	1
-1dB	0	1	1	1
-2dB	1	0	1	1
-3dB	0	0	1	1
-4dB	1	1	0	1
-6dB	0	1	0	1
-8dB	1	0	0	1
-10dB	0	0	0	1
-12dB	1	1	1	0
-14dB	0	1	1	0
-16dB	1	0	1	0
-20dB	0	0	1	0
-30dB	1	1	0	0
-45dB	0	1	0	0
-60dB	1	0	0	0
-∞ dB	0	0	0	0

THE ELECTRIC VOLUME of BUILD-IN NON FADER VOLUME with TONE CONTROL

**LOUDNESS, TONE CONTROL FREQUENCY CHARACTERISTIC**

fig.1) Loudness Frequency Characteristic

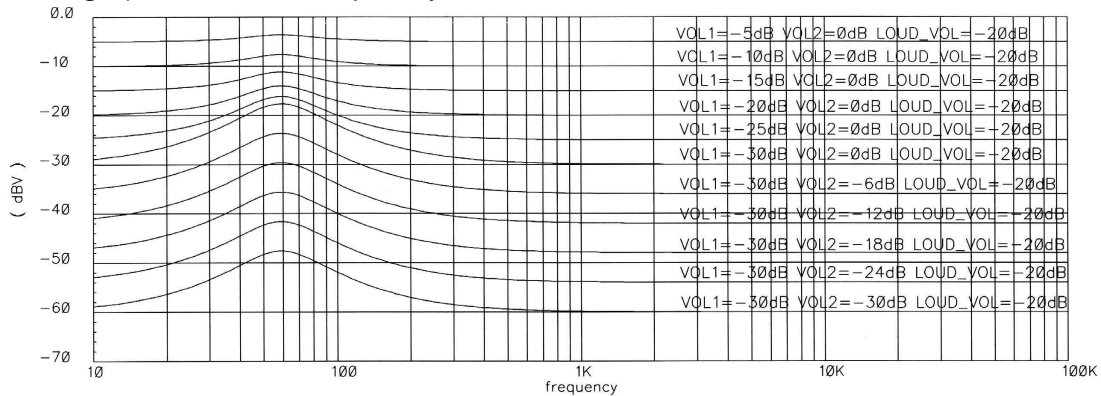

fig.2) Loudness Frequency Characteristic(VOL=-30dB,Loudness=-20dB,fO=Variable)

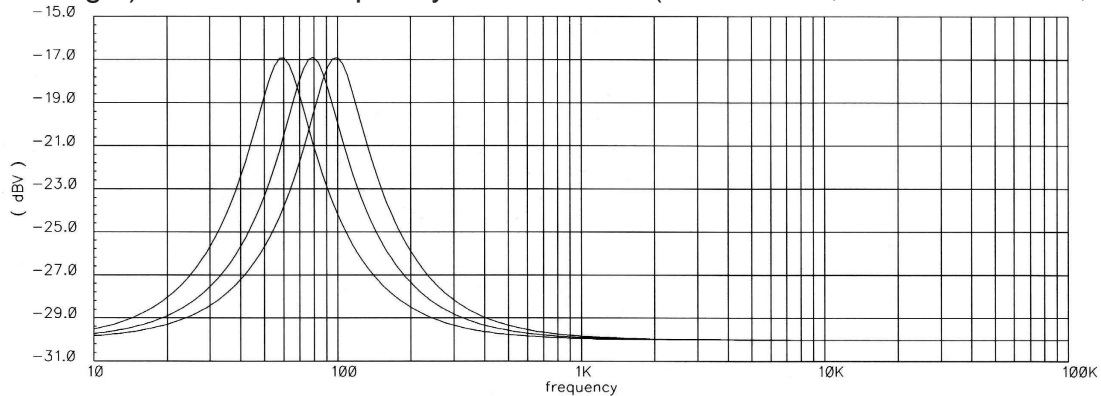

fig.3) Bass Frequency Characteristic(fO=50Hz,Q=2,Gv=Variable)

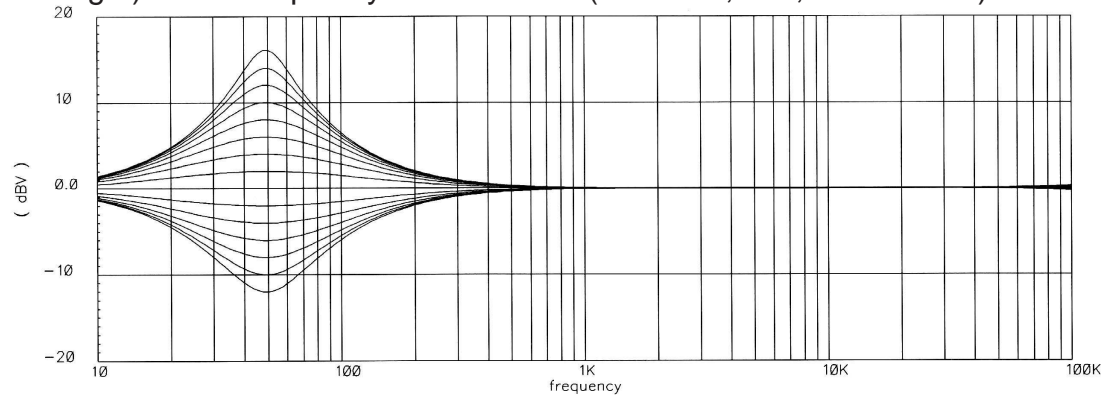
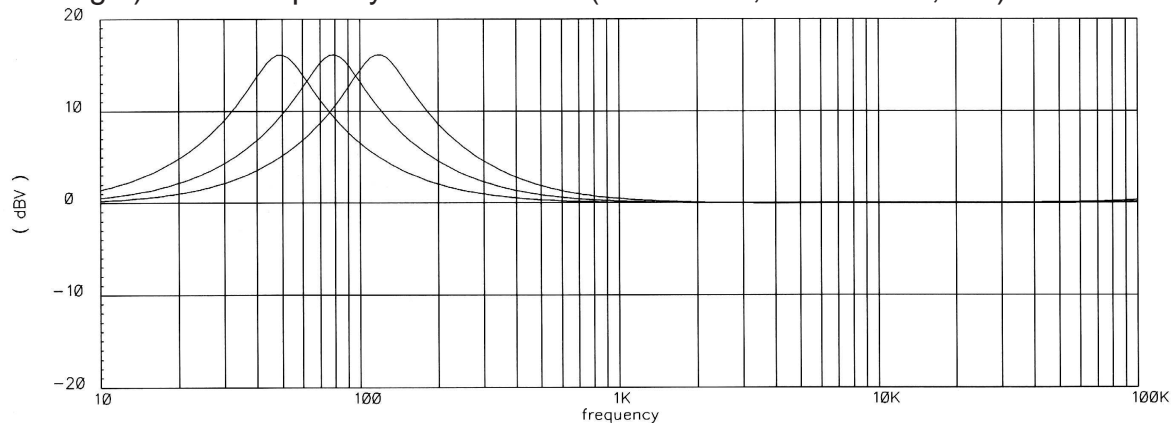

fig.4) Bass Frequency Characteristic(Gv=+16dB,fO=Variable,Q=2)



THE ELECTRIC VOLUME of BUILD-IN NON FADER VOLUME with TONE CONTROL

fig.5) Bass Frequency Characteristic ( $G_v=+16\text{dB}$ ,  $Q=\text{Variable}$ ,  $f_0=50\text{Hz}$ )

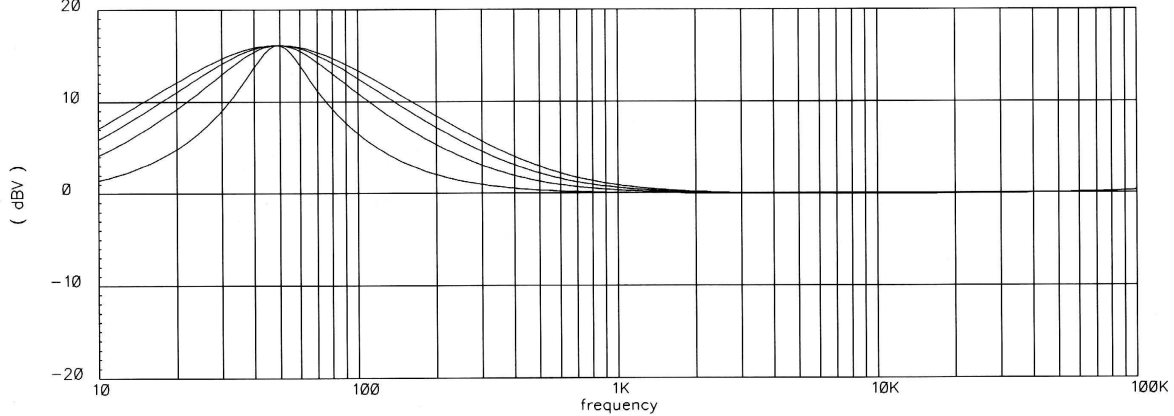

fig.6) Mid Frequency Characteristic ( $f_0=1\text{kHz}$ ,  $Q=2$ ,  $G_v=\text{Variable}$ )

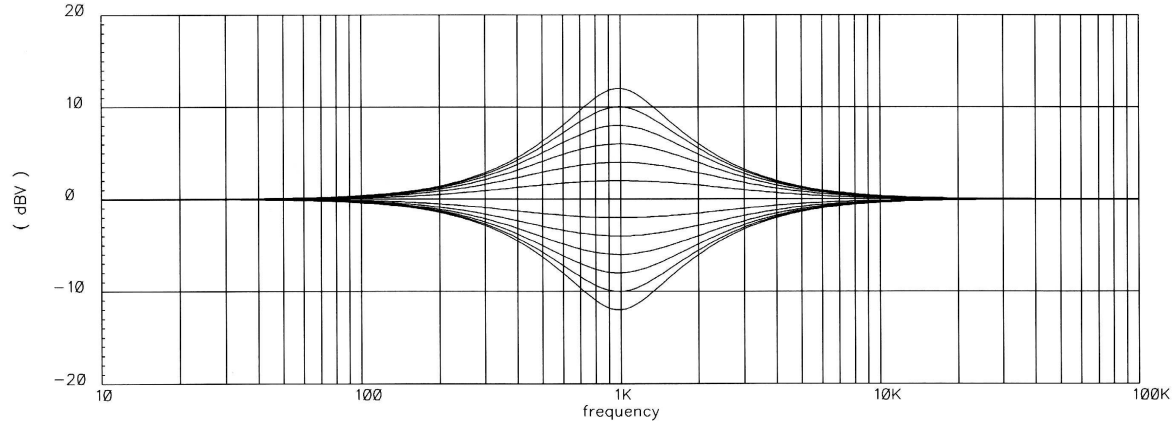

fig.7) Mid Frequency Characteristic ( $G_v=+12\text{dB}$ ,  $Q=2$ ,  $f_0=\text{Variable}$ )

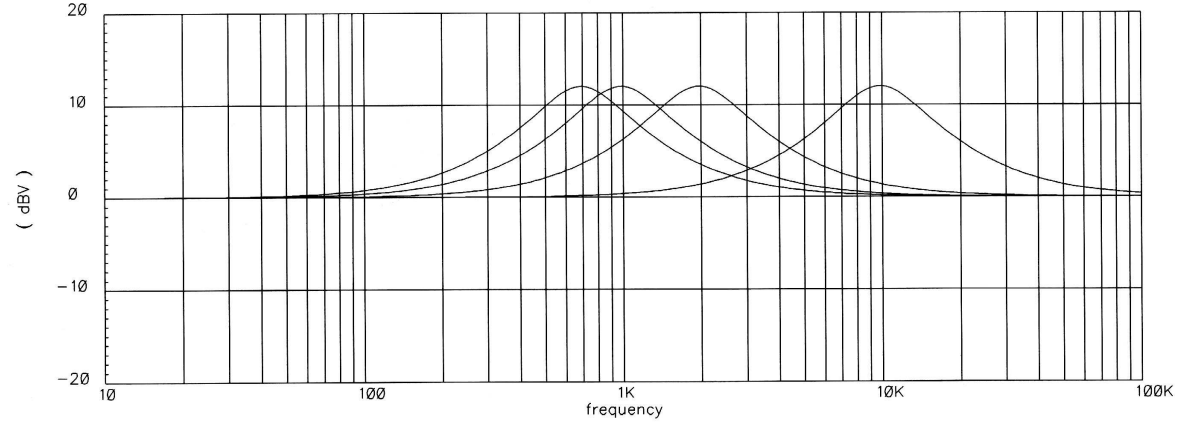
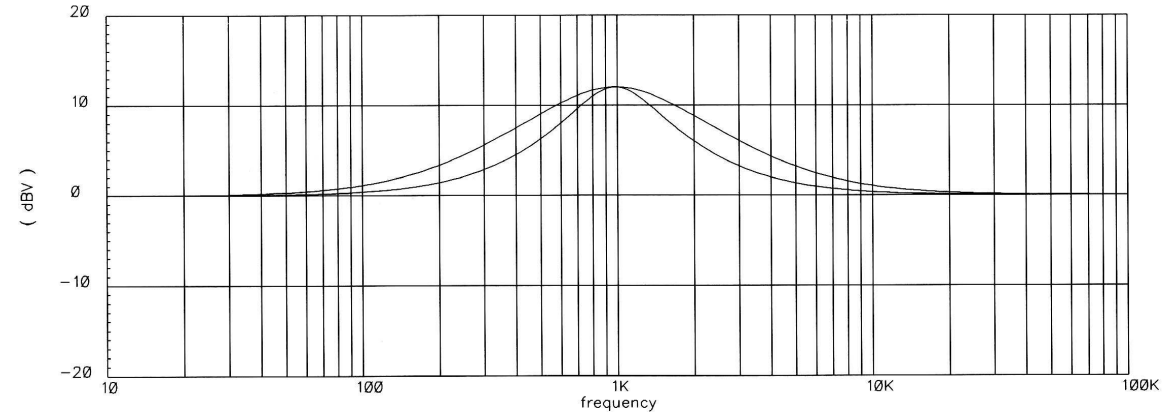

fig.8) Mid Frequency Characteristic ( $G_v=+12\text{dB}$ ,  $f_0=1\text{kHz}$ ,  $Q=\text{Variable}$ )



THE ELECTRIC VOLUME of BUILD-IN NON FADER VOLUME with TONE CONTROL

fig.9) Treble Frequency Characteristic (Gv=Variable)

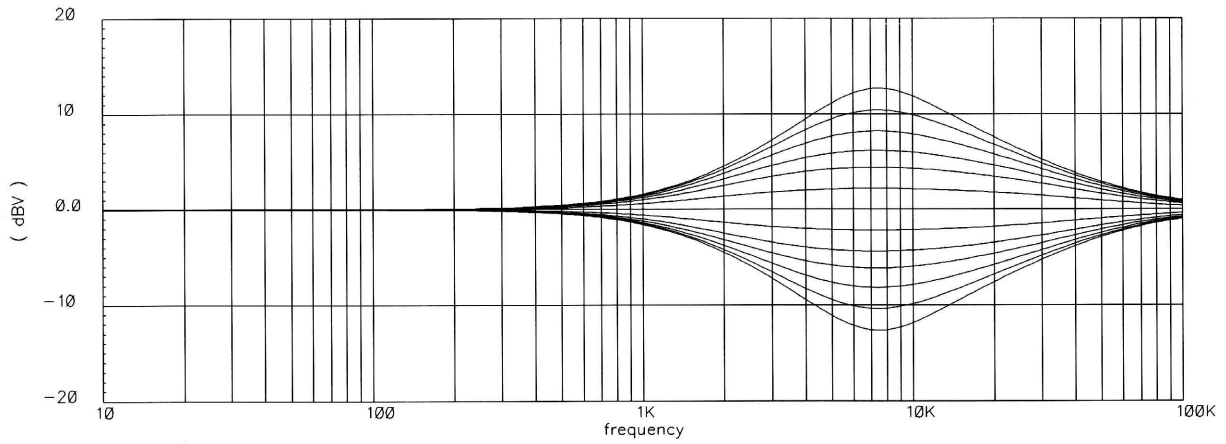
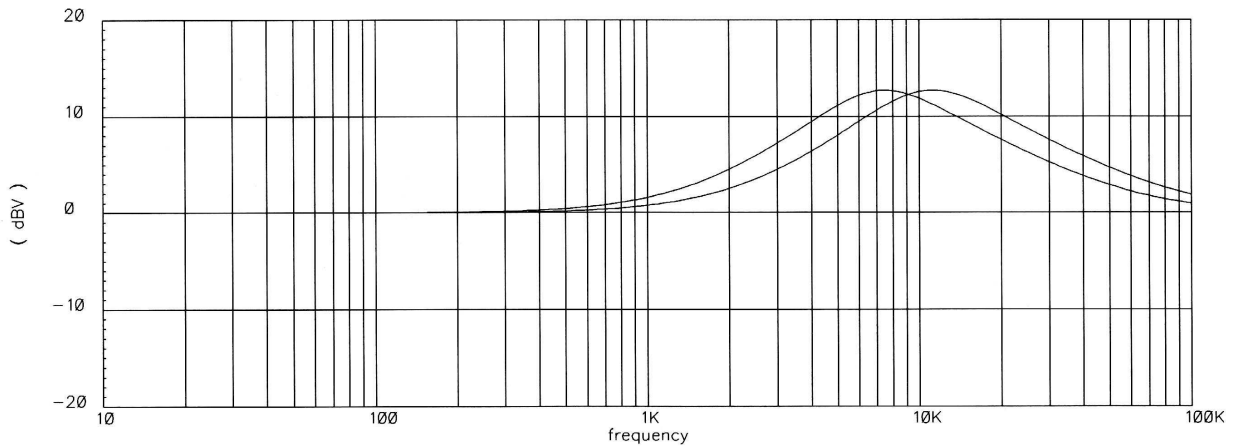

fig.10) Treble Frequency Characteristic (Gv=+12dB, fO=Variable)



## ZERO-CROSSING DETECTION CIRCUIT

### 1. Meaning of Zero-Crossing Detection Circuit

In the conventional Serial Data Control Type Volume, Analog SW inside switches over simultaneously with Latch Condition Detector. And the operation completes.

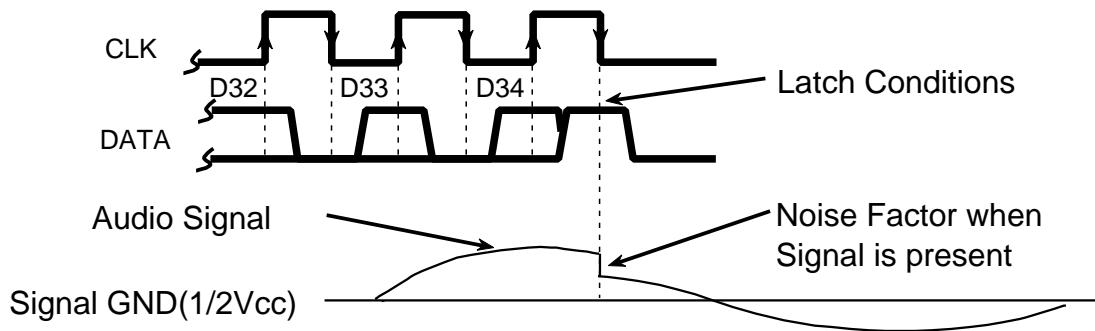

In this case the changing noise occurs at the time of Latch Condition Detector, the Analog SW switches over (Zero-cross Detector Strobe occurs) in the moment that the Analog Signal cross Signal Ground (1/2VCC).

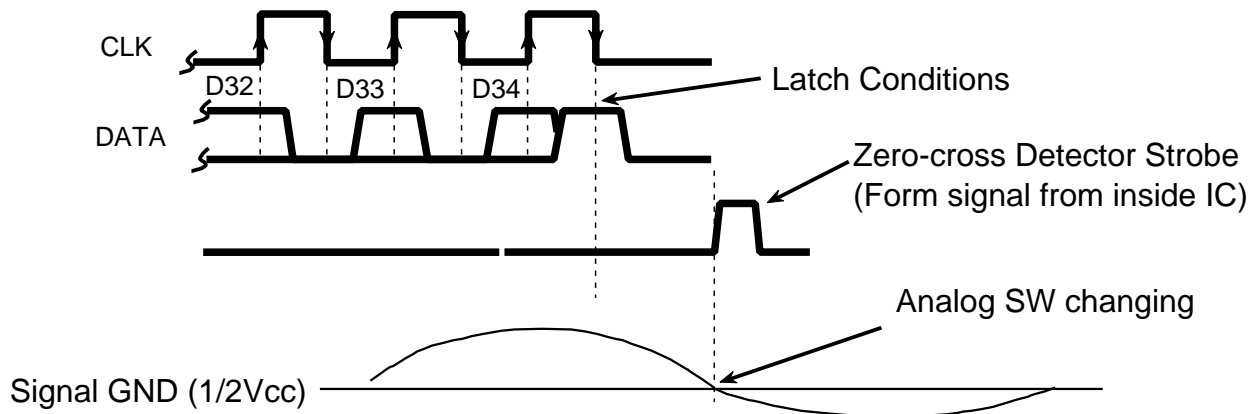

Other, In the case of Audio Signal isn't inputted (No signal), even if only Zero-cross Detector Circuit detects Latch Condition, Analog SW doesn't switch over for the Audio Signal never cuts Signal Ground (1/2VCC).

The Time Function switches the Analog SW after some time T.

The Timer Time can setting with the Serial Data of 5mS, 10mS, 15mS, 20mS.



THE ELECTRIC VOLUME of BUILD-IN NON FADER VOLUME with TONE CONTROL

2. Connection of Zero-Crossing Detector and Timer Setting

"OR" of [Zero-cross Detector Strobe] or [Compulsion SW of Timer Circuit] moves Internal Analog SW . When for example, suppose that it set to T=10msec.

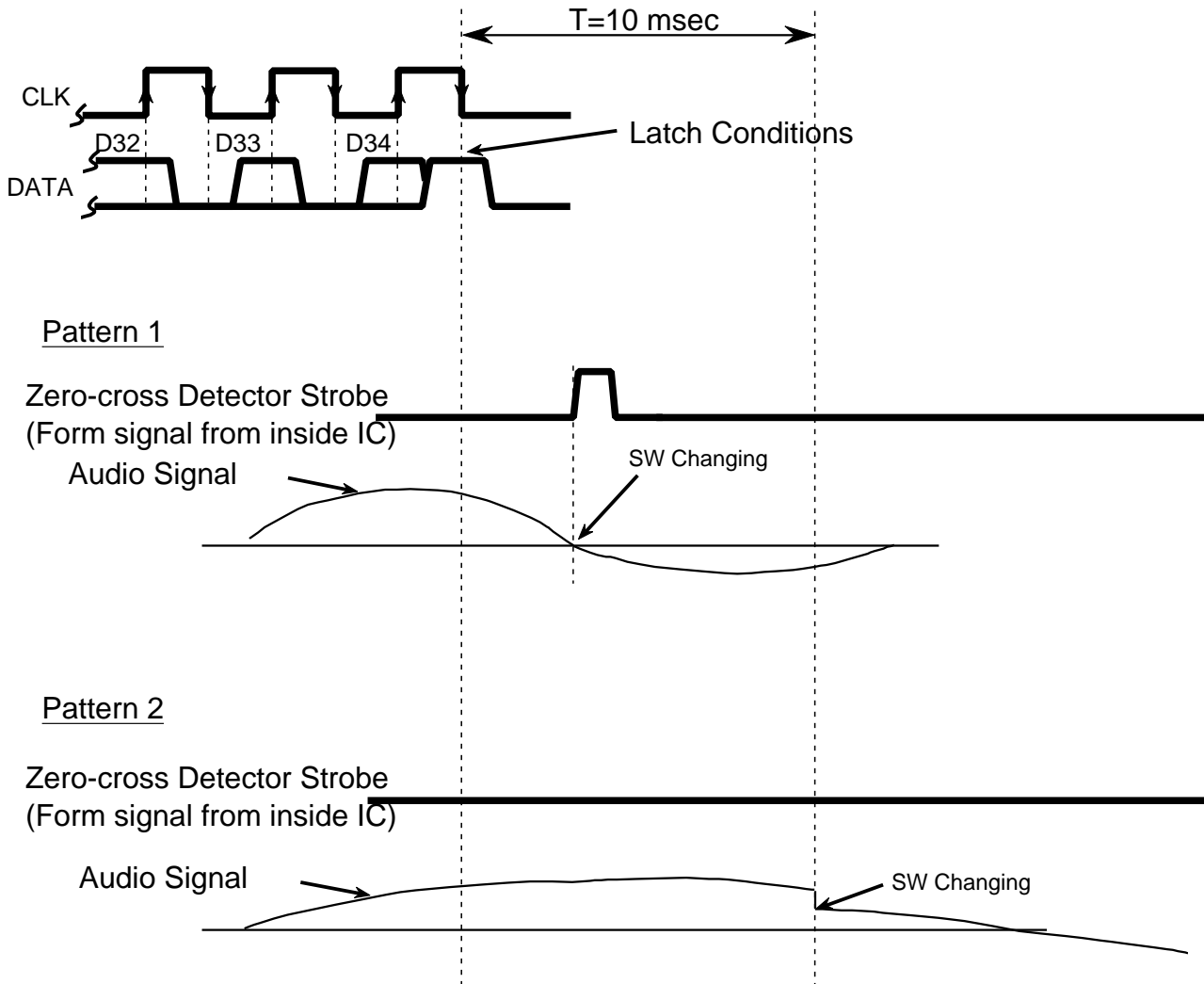

In case of Pattern1, the Zero-cross Detector Strobe occurs with the Zero-cross Detector Function, and SW is switched. But in case of Pattern2, the Timer Function switches the Analog SW after T=10msec, for the Audio Input Signal didn't cut the Signal Ground after T=10msec which were set with the timer.

Timer Setting Time setting for Frequency band of Input Audio Signal.

THE ELECTRIC VOLUME of BUILD-IN NON FADER VOLUME with TONE CONTROL

3. Timer Setting System

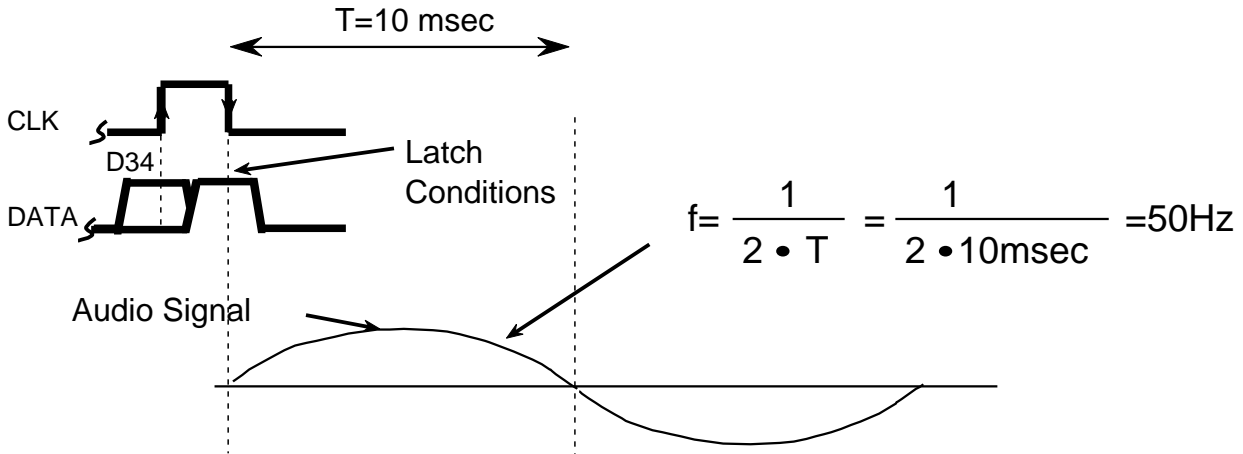

In case of Timer Setting Time/T =10 msec setting

Audio Signal	Zero-cross Detector	
50Hz <	100%	Upper fig.
50Hz >	100%	Pattern 1
	0%	Pattern 2

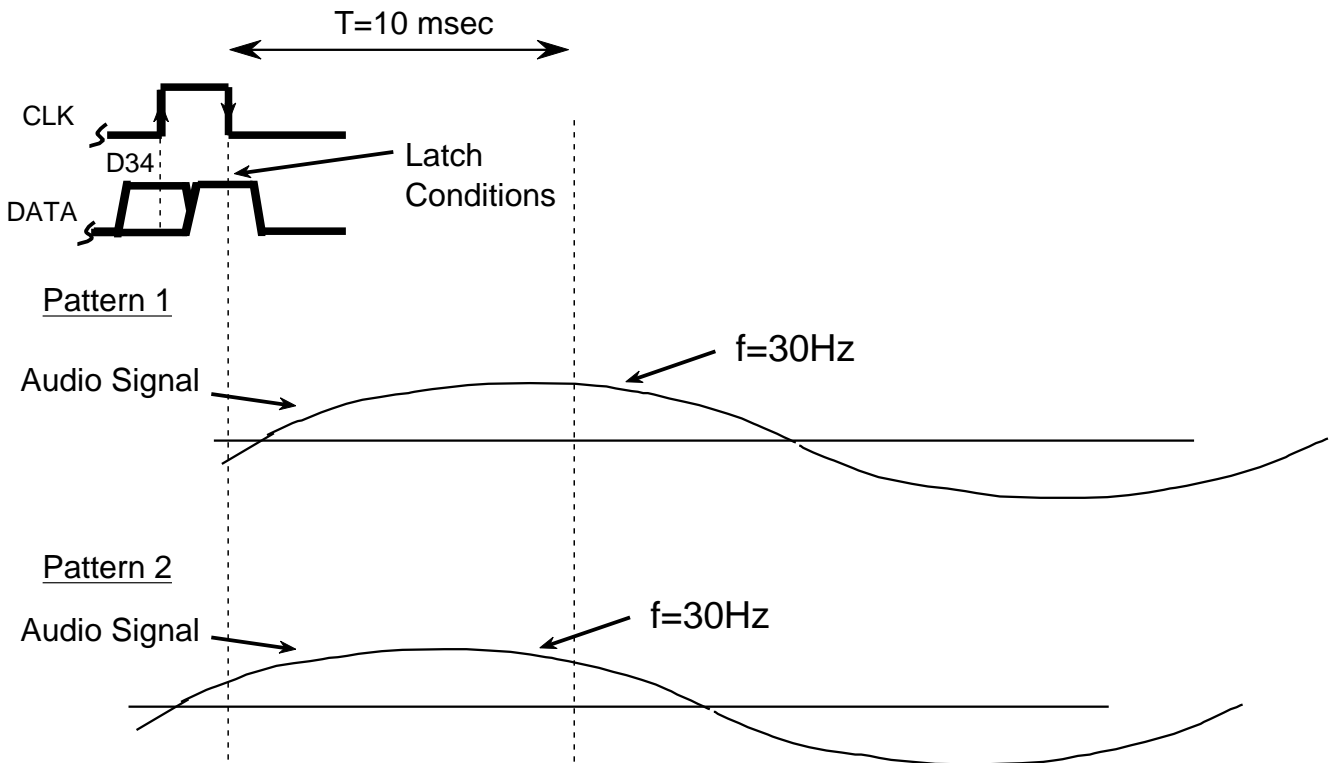

The Timer Setting Time T makes T=20msec (Zero-cross detect of 25Hz is 100%) maximum and it is setting by it.

THE ELECTRIC VOLUME of BUILD-IN NON FADER VOLUME with TONE CONTROL

4. Connection of Data Transmission and Timer Setting

M61508FP has the function to make the Serial Data invalid until it generations the Zero-cross Detector Strobe in IC, after the Latch Condition detected.

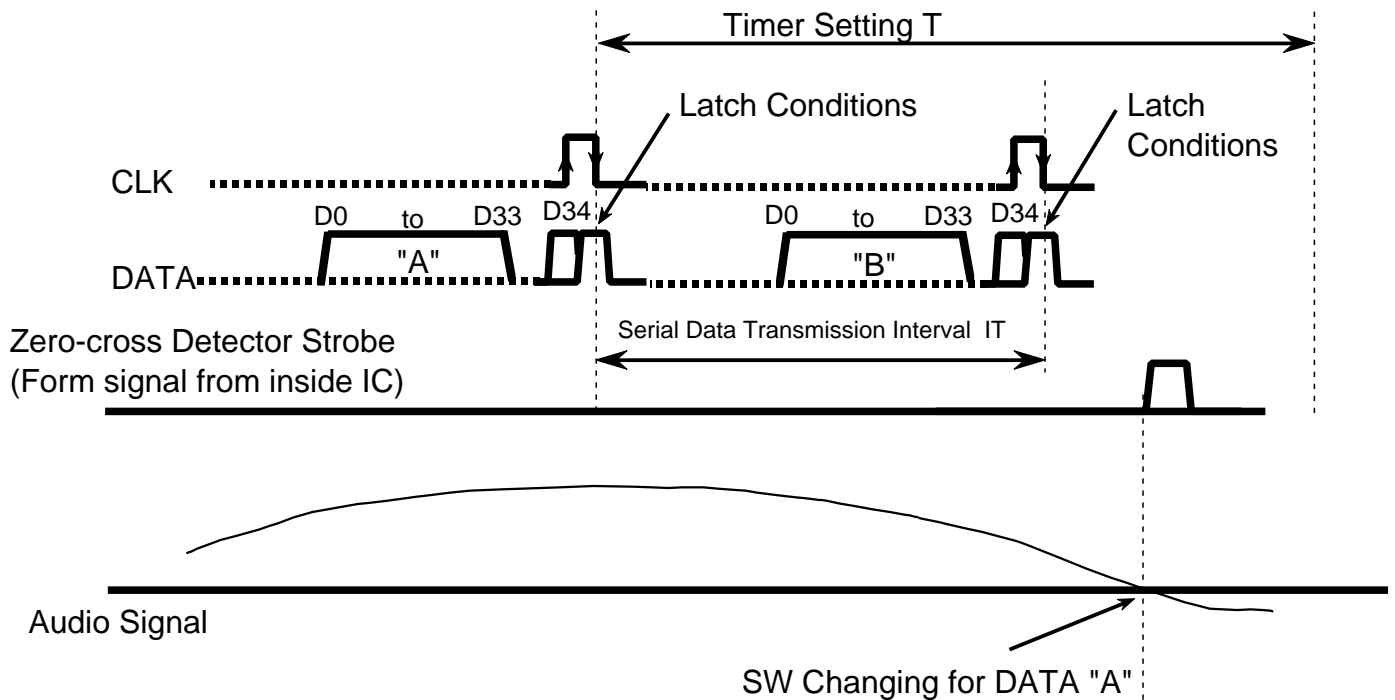

\* In case of upper figurative. The order of DATA "B" is invalid.

In to make the Serial Data Transmission Interval IT from MCU(microcomputer) to M61508FP

$$\text{Serial Data Transmission Interval} = IT > \text{Timer Setting} = T$$

the reading error of the data doesn't occur.

\*Serial Data Transmission Interval IT =Interval of between Latch Condition and Latch Condition

Notice ; This is not a final specification.  
some parametric limits are subject to change.

# M61508FP

## THE ELECTRIC VOLUME of BUILD-IN NON FADER VOLUME with TONE CONTROL

### THE OTHERS

1. Differential Amp.  
The lower fig. is Equalizing Circuit, Output Signal /Output Voltage of each point.

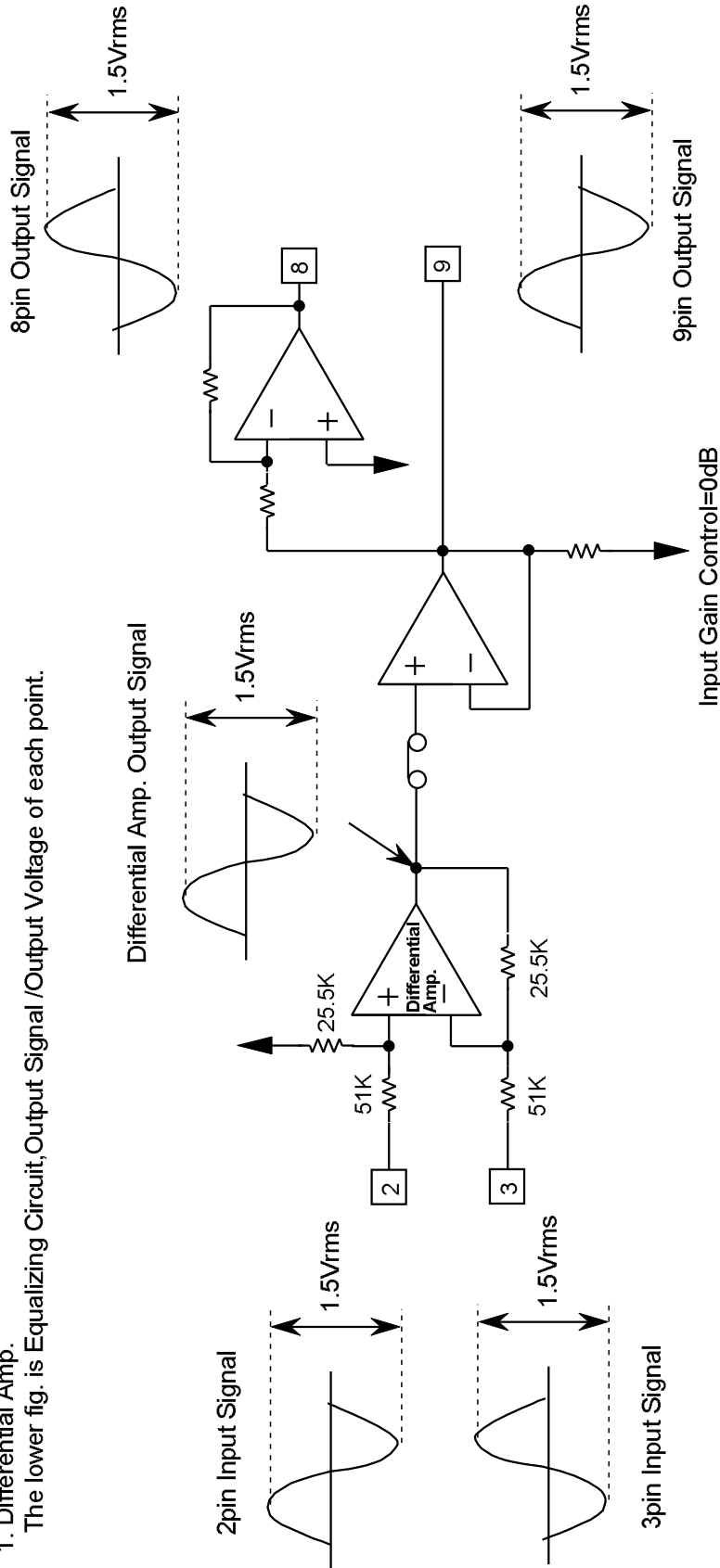

### ● Differential Amp. Gain Calculation Formula

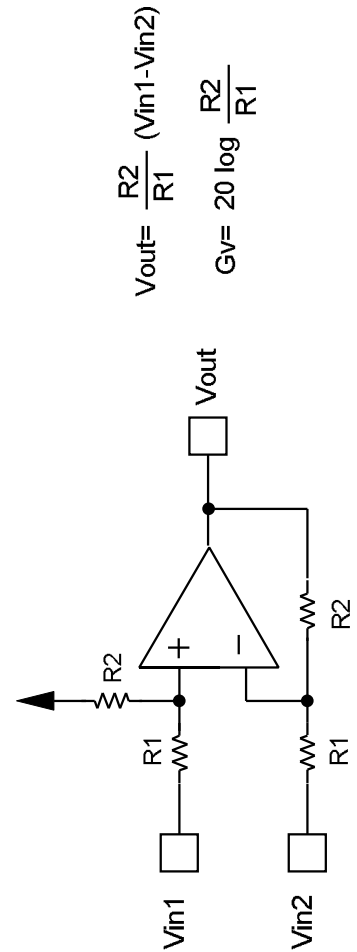

$$V_{out} = \frac{R2}{R1} (V_{in1} - V_{in2})$$

$$G_v = 20 \log \frac{R2}{R1}$$

THE ELECTRIC VOLUME of BUILD-IN NON FADER VOLUME with TONE CONTROL

2 LOUDNESS GAIN SETTING

Lower Figure is Structure of Loudness Circuit.

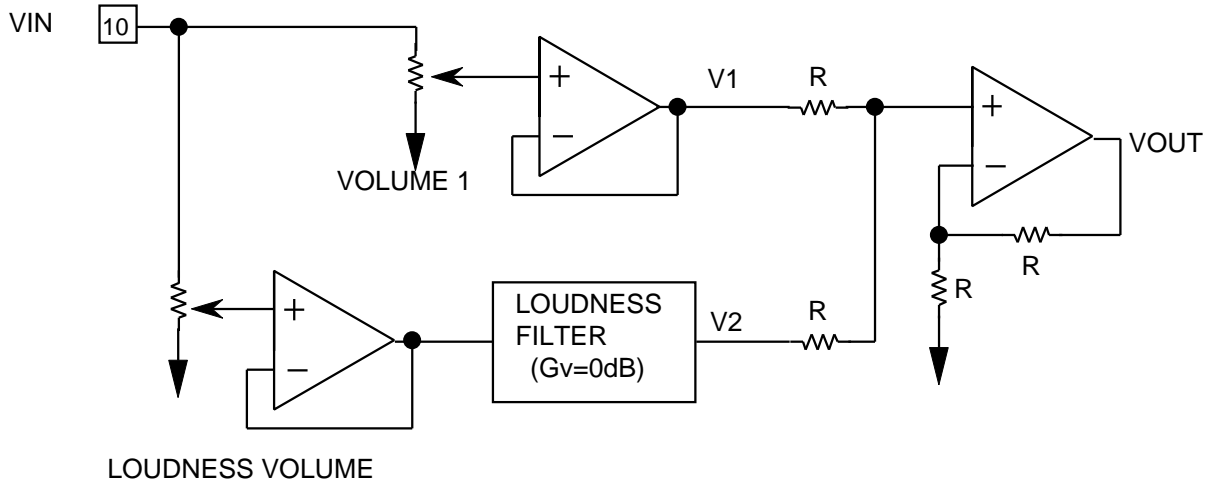

Output Volutage (VOUT) of Setting Structure of Upper Figure

It is noted as Volume1Output Volutage = V1, Loudness Filter Output Voltage = V2, VOUT and Gv (Boost quantity) is given at the lower formula

$$VOUT = V1 + V2 \text{ (Vrms)}$$

$$Gv = 20 \log \frac{(V1 + V2)}{VIN} - (\text{Volume 1 attenuation quantity}) \text{ (dB)}$$

ex.) VIN = 1Vrms/60Hz, Volume1= -30dB,  
Output Volutage and Boost Quantity of 60Hz of Loudness Volume = -20dB setting

From : Volume1, Loudness Volume attenuation quantity  
Become : V1 = 31.6mVrms  
V2 = 100mVrms

If the subsitutes the equation for the upper formula,  
the following equation is given :

$$VOUT = 31.6m + 100m \\ = 131.6mVrms$$

$$Gv = 20 \log \frac{(31.6m + 100m)}{1} - (-30dB) \\ = 12.4dB \text{ is obtained.}$$

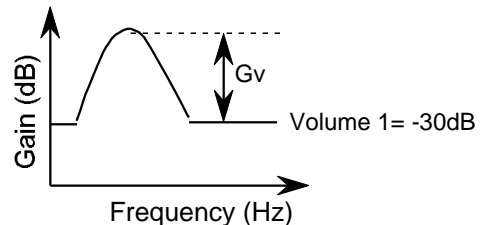

In the item, the Loudness Gain Setting example is shown, when Volume1 fixation and doing the Loudness Volume variably. Please refer to Plan.

**THE ELECTRIC VOLUME of BUILD-IN NON FADER VOLUME with TONE CONTROL**

● **LOUDNESS GAIN SETTING EXAMPLE**

1 Volume1= -10dB

LOUDNESS VOLUME	LOUDNESS GAIN
-2dB	10.9dB
-4dB	9.5dB
-6dB	8.2dB
-8dB	7.1dB
-10dB	6.0dB
-12dB	5.1dB
-14dB	4.2dB
-16dB	3.5dB
-18dB	2.9dB
-20dB	2.4dB
-22dB	1.9dB
-24dB	1.6dB
-26dB	1.3dB
-28dB	1.0dB
-30dB	0.8dB
-∞ dB	0dB

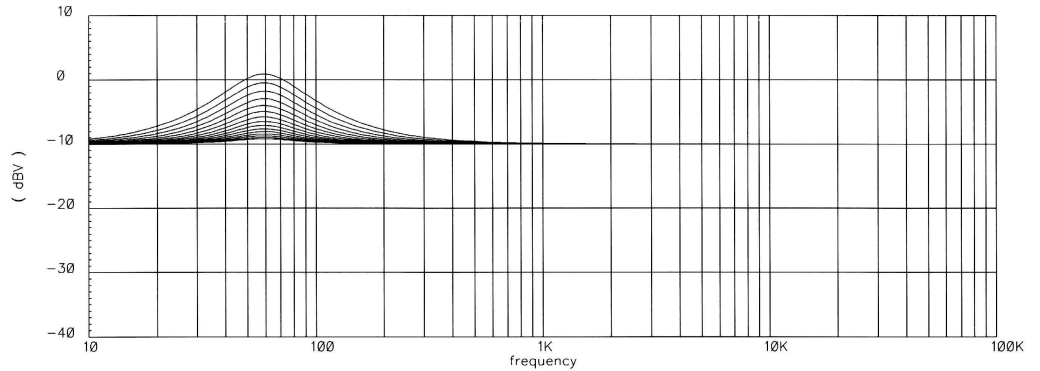

2 Volume1= -20dB

LOUDNESS VOLUME	LOUDNESS GAIN
-2dB	19.0dB
-4dB	17.3dB
-6dB	15.6dB
-8dB	13.9dB
-10dB	12.4dB
-12dB	10.9dB
-14dB	9.5dB
-16dB	8.2dB
-18dB	7.1dB
-20dB	6.0dB
-22dB	5.1dB
-24dB	4.2dB
-26dB	3.5dB
-28dB	2.9dB
-30dB	2.4dB
-∞ dB	0dB

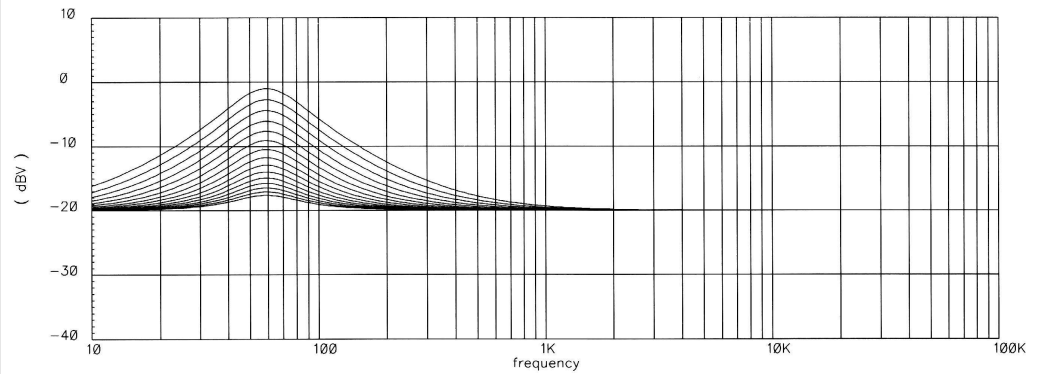

3 Volume 1=-30dB

LOUDNESS VOLUME	LOUDNESS GAIN
-2dB	28.3dB
-4dB	26.4dB
-6dB	24.5dB
-8dB	22.7dB
-10dB	20.8dB
-12dB	19.0dB
-14dB	17.3dB
-16dB	15.6dB
-18dB	13.9dB
-20dB	12.4dB
-22dB	10.9dB
-24dB	9.5dB
-26dB	8.2dB
-28dB	7.1dB
-30dB	6.0dB
-∞ dB	0dB

