

# MSM5052

## Built-in Temperature Circuit and LCD Driver 4-Bit Microcontroller

### GENERAL DESCRIPTION

The MSM5052 is a low-power microcontroller manufactured in complementary metal-oxide semiconductor technology. Integrated into a single chip are ROM, RAM, crystal oscillator, voltage doubler, timer, LCD driver, input port, output port, and thermistor-based temperature measuring circuit.

Using an on-chip ROM reduces power consumption.

The MSM5052 is widely used in electronic products requiring low-power operation, for example, thermometer and clinical thermometer.

### FEATURES

- Low power consumption
  - Internal ROM : 1280 × 14 bits
  - Internal RAM : 62 × 4 bits
  - I/O port
    - Input port : 2 ports × 4 bits
    - Output port : 1 port × 4 bits
    - 1 port × 1 bit
  - 4 × 4 key matrix input is available by using K<sub>1</sub> to K<sub>4</sub> and M<sub>1</sub> to M<sub>4</sub>
  - 26 LCD drivers (1/2 duty, 1/2 bias, 52 segments)
  - 42 instructions
  - Minimum instruction execution time : 122.1 μs (Display instruction cycle: 244.2 μs)
  - 1.5 V operating voltage (Built-in LCD drive voltage doubler)
  - Buzzer function
  - Built-in thermistor-based temperature measuring circuit
  - Crystal oscillator : 32.768 kHz
  - Package options:
    - 56-pin plastic QFP (QFP56-P-910-0.65-K) : (Product name : MSM5052-xxxGS-K)
    - 56-pin plastic QFP (QFP56-P-910-0.65-2K) : (Product name : MSM5052-xxxGS-2K)
    - 80-pin plastic QFP (QFP80-P-1420-0.80-BK): (Product name : MSM5052-xxxGS-BK)
    - Chip (Chip size 4.77 mm × 4.36 mm) : (Product name : MSM5052-xxx)
- xxx indicates a code number.

BLOCK DIAGRAM

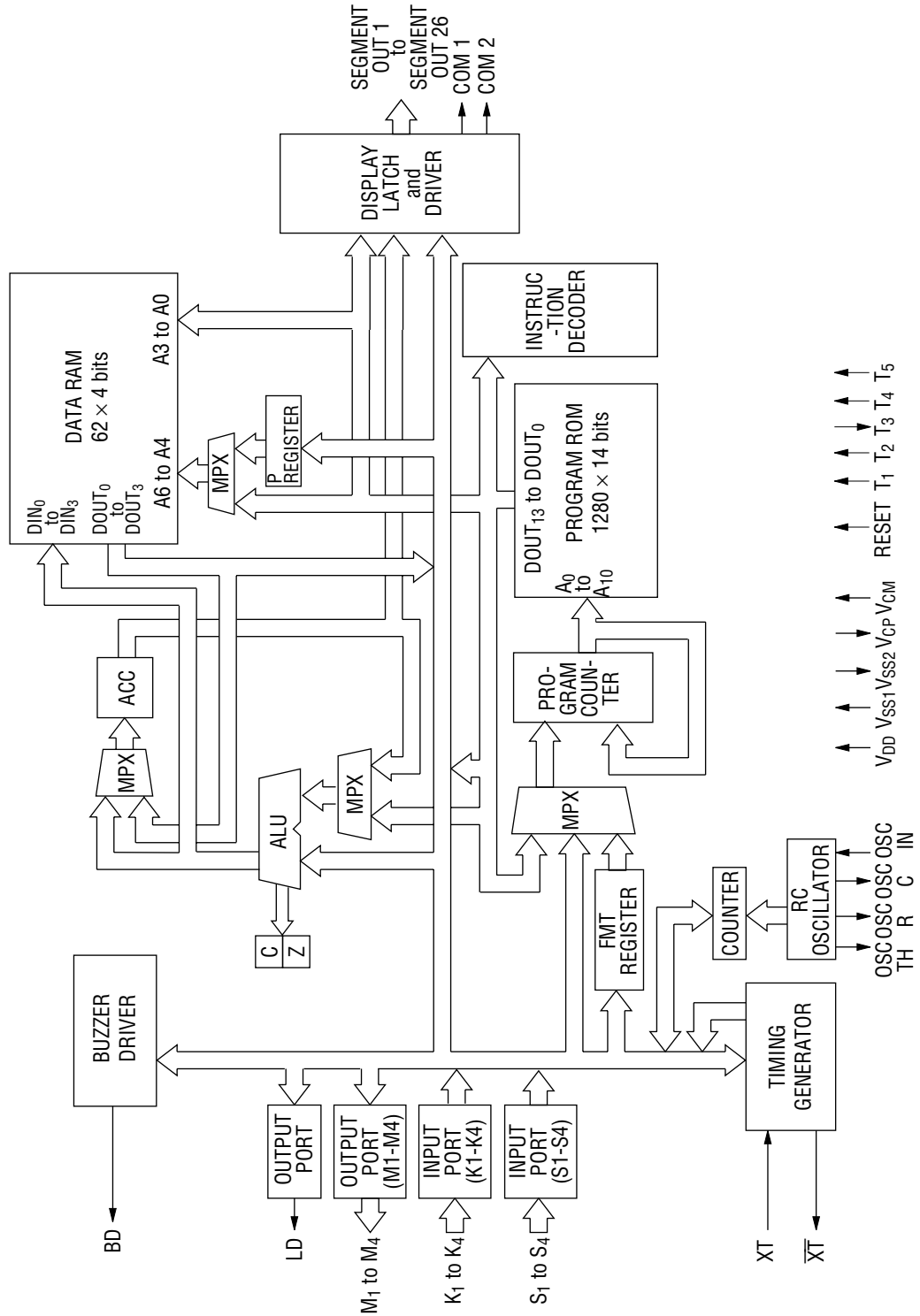

**PIN CONFIGURATION (TOP VIEW)**

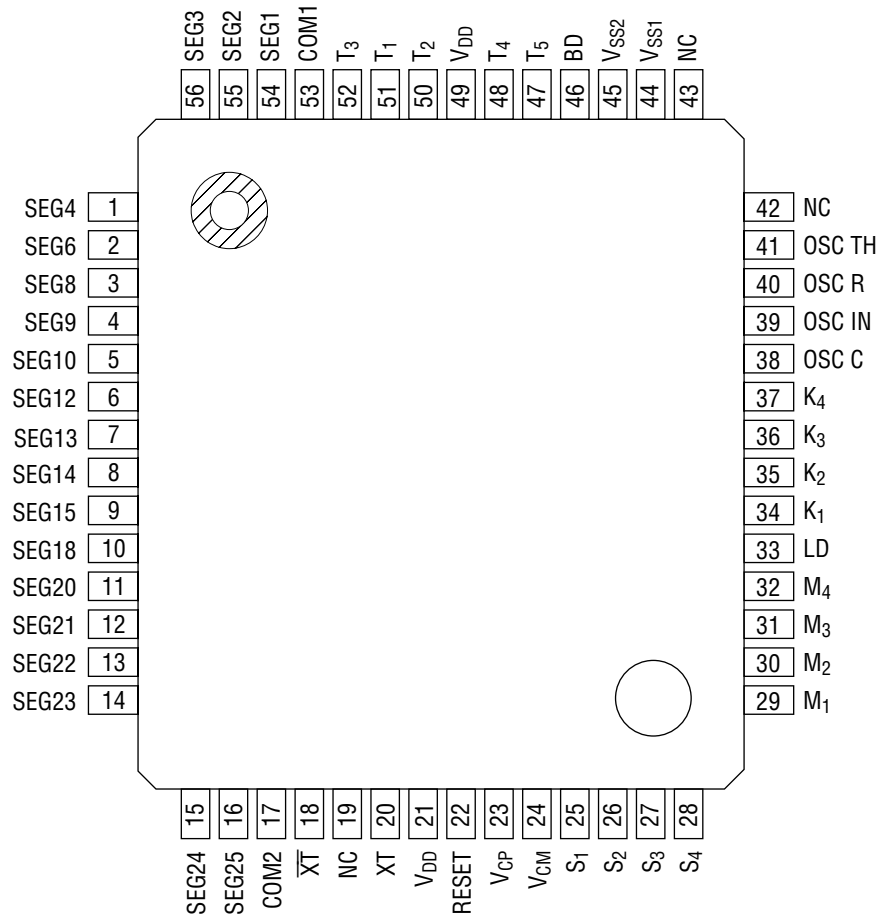

NC: No-connection pin

**56-Pin Plastic QFP**

Note: SEG5, SEG7, SEG11, SEG16, SEG17, SEG19, and SEG26 are not connected to package pins.

**PIN CONFIGURATION (TOP VIEW) (continued)**

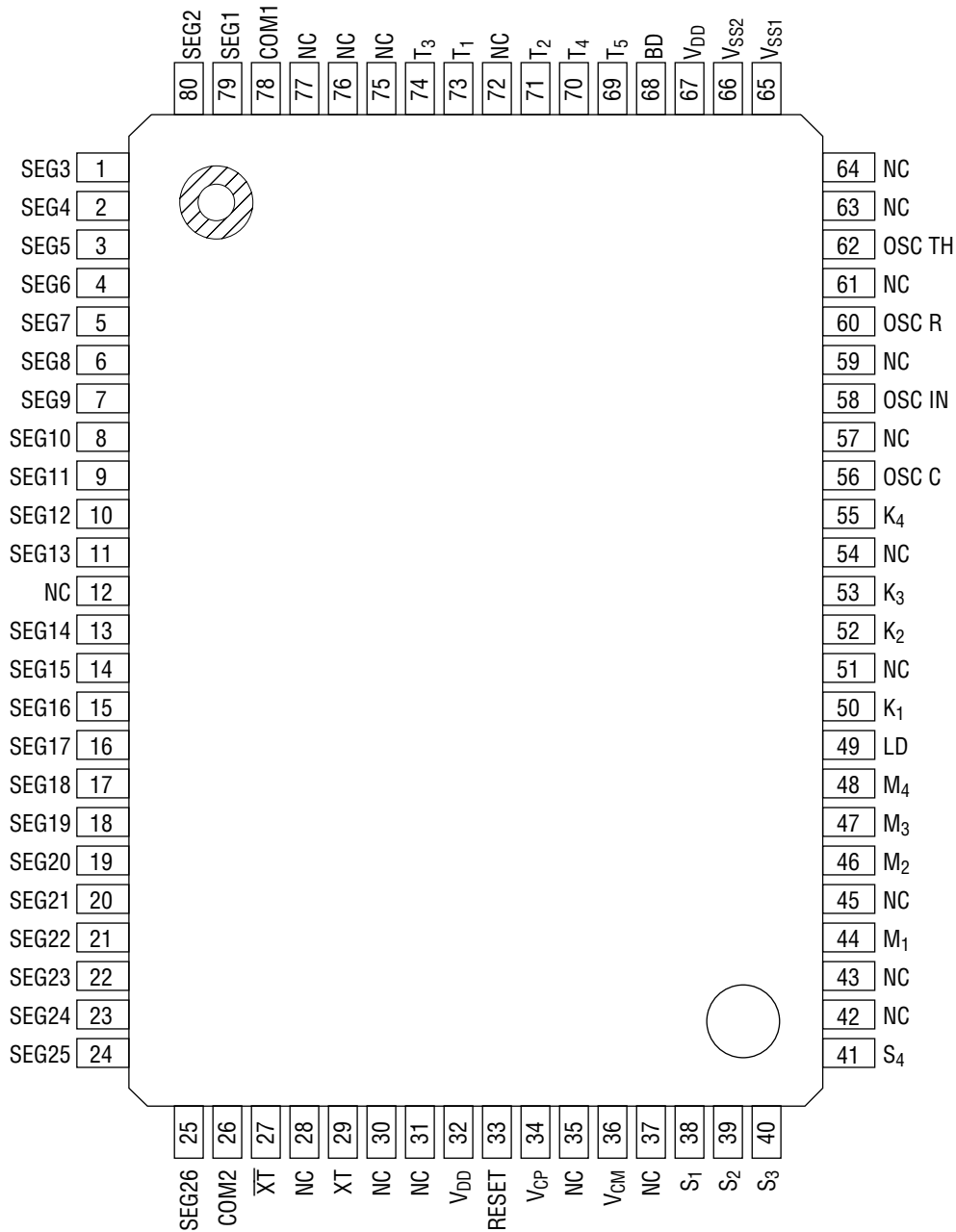

NC: No-connection pin

**80-Pin Plastic QFP**

**PAD CONFIGURATION**

**Pad Layout**

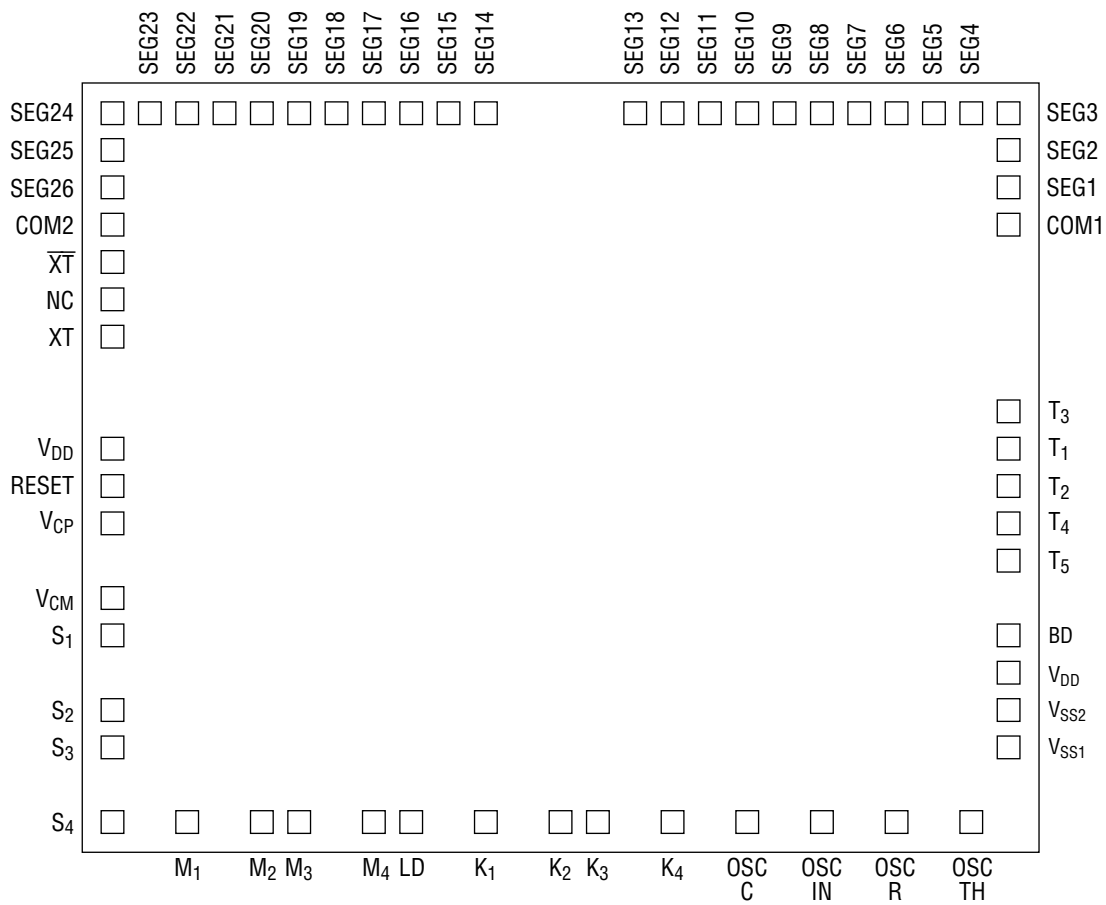

**Chip size 4.77 × 4.36 (mm)**

**PIN DESCRIPTIONS**

<b>Symbol</b>	<b>Description</b>
$V_{DD}$	Ground.
$V_{SS1}$	Power source (-1.5 V).
$V_{SS2}$	Power source for LCD driver (-3.0 V). This pin is connected to the $V_{DD}$ pin through a 0.1 $\mu$ F capacitor.
$V_{CP}, V_{CM}$	Booster capacitor connection pins. $V_{CP}$ pin is connected to the $V_{CM}$ pin through a 0.1 $\mu$ F capacitor.
XT, $\overline{XT}$	Input and output pins of oscillator inverter. A 32.768 kHz crystal is connected to these pins.
T1 to T5	Pins to test internal logic. T1, T2, T4, and T5 are pulled down to $V_{SS1}$ . T3 is the output. Test pins are normally open.
RESET	Pin to clear internal logic, pulled down to $V_{SS1}$ . After power is turned on, the MSM5052 can be reset by this pin.
BD	Buzzer output.
OSC TH, OSC R, OSC C, OSC IN	Pins to RC oscillation circuit for temperature detection. These are the fundamental resistor, thermistor, and capacitor connection pins.

## ABSOLUTE MAXIMUM RATINGS

Parameter	Symbol	Condition	Rating	Unit
Power Supply Voltage	$V_{SS1}-V_{DD}$	$T_a = 25^\circ\text{C}$	-2.0 to +0.3	V
Input Voltage	$V_{IN}$	$T_a = 25^\circ\text{C}$	$V_{SS1} - 0.3$ to +0.3	V
Storage Temperature	$T_{STG}$	—	-55 to +125	$^\circ\text{C}$
Operating Temperature	$T_{op}$	—	-20 to +75	$^\circ\text{C}$

## ELECTRICAL CHARACTERISTICS

### DC Characteristics

( $V_{DD} = 0\text{ V}$ ,  $V_{SS1} = -1.55\text{ V}$ ,  $V_{SS2} = -3.0\text{ V}$ ,  $C_1 = 30\text{ pF}$ ,  $T_a = 25^\circ\text{C}$ )

Parameter	Symbol	Condition	Min.	Typ.	Max.	Unit
$V_{SS1}$ Operating Voltage	$V_{SS1}$	$V_{SS1}$ pin	-1.65	-1.55	-1.25	V
Power Supply Current 1	$I_{DD1}$	Temperature sampling off (Refer to measuring circuit)	—	3.0 *1	—	$\mu\text{A}$
Power Supply Current 2	$I_{DD2}$	Temperature sampling on (Refer to measuring circuit)	—	100 *2	—	$\mu\text{A}$
Oscillation Start Voltage	$V_{OSC}$	Within 10 seconds, $V_{SS1}$ pin (Refer to measuring circuit)	—	—	-1.45	V
Output Current 1 COM	$I_{OH1}$	$V_{OH1} = -0.2\text{ V}$	—	—	-4	$\mu\text{A}$
	$I_{OM1}$	$V_{OM1} = V_{SS1} \pm 0.2\text{ V}$	-4	—	+4	
	$I_{OL1}$	$V_{OL1} = -2.8\text{ V}$	4	—	—	
Output Current 2 SEGMENT	$I_{OH2}$	$V_{OH2} = -0.2\text{ V}$	—	—	-0.4	$\mu\text{A}$
	$I_{OL2}$	$V_{OL2} = -2.8\text{ V}$	0.4	—	—	
Output Current 3 C, R, TH	$I_{OH3}$	$V_{OH3} = -0.4\text{ V}$	—	—	-400	$\mu\text{A}$
	$I_{OL3}$	$V_{OL3} = -1.15\text{ V}$	400	—	—	
Output Current 4 $M_1-M_4$ , LD	$I_{OH4}$	$V_{OH4} = -0.4\text{ V}$	—	—	-100	$\mu\text{A}$
	$I_{OL4}$	$V_{OL4} = -1.15\text{ V}$	10	—	—	
Output Current 5 BD	$I_{OH5}$	$V_{OH5} = -0.4\text{ V}$	-200	—	-50	$\mu\text{A}$
	$I_{OL5}$	$V_{OL5} = -1.15\text{ V}$	3	—	—	
Input Current $S_1-S_4$ , $K_1-K_4$	$I_{IH}$	$V_{IN} = 0\text{ V}$	3	—	30	$\mu\text{A}$
	$I_{IL}$	$V_{IN} = -1.55\text{ V}$	-0.2	—	—	
Built-in CD Capacitance	CD	—	—	25	—	pF

\*1 The typ. value varies depending on the application program.

\*2 The typ. value varies depending on the application program and RC thermistor to be used.

Measuring circuit

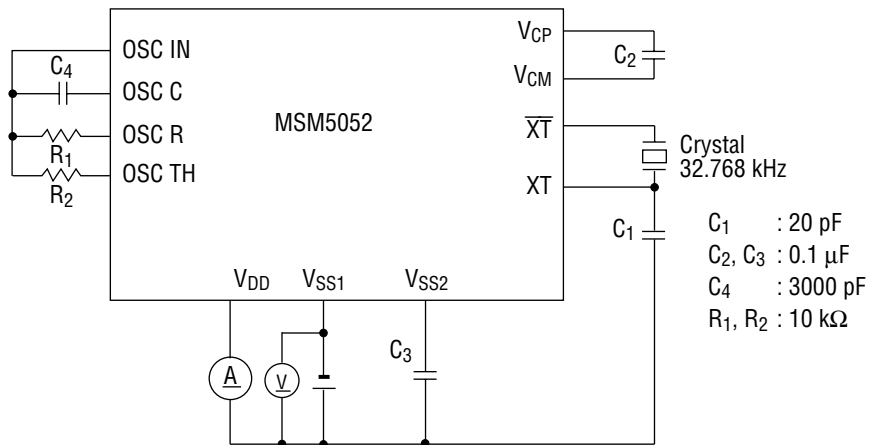



APPLICATION CIRCUIT

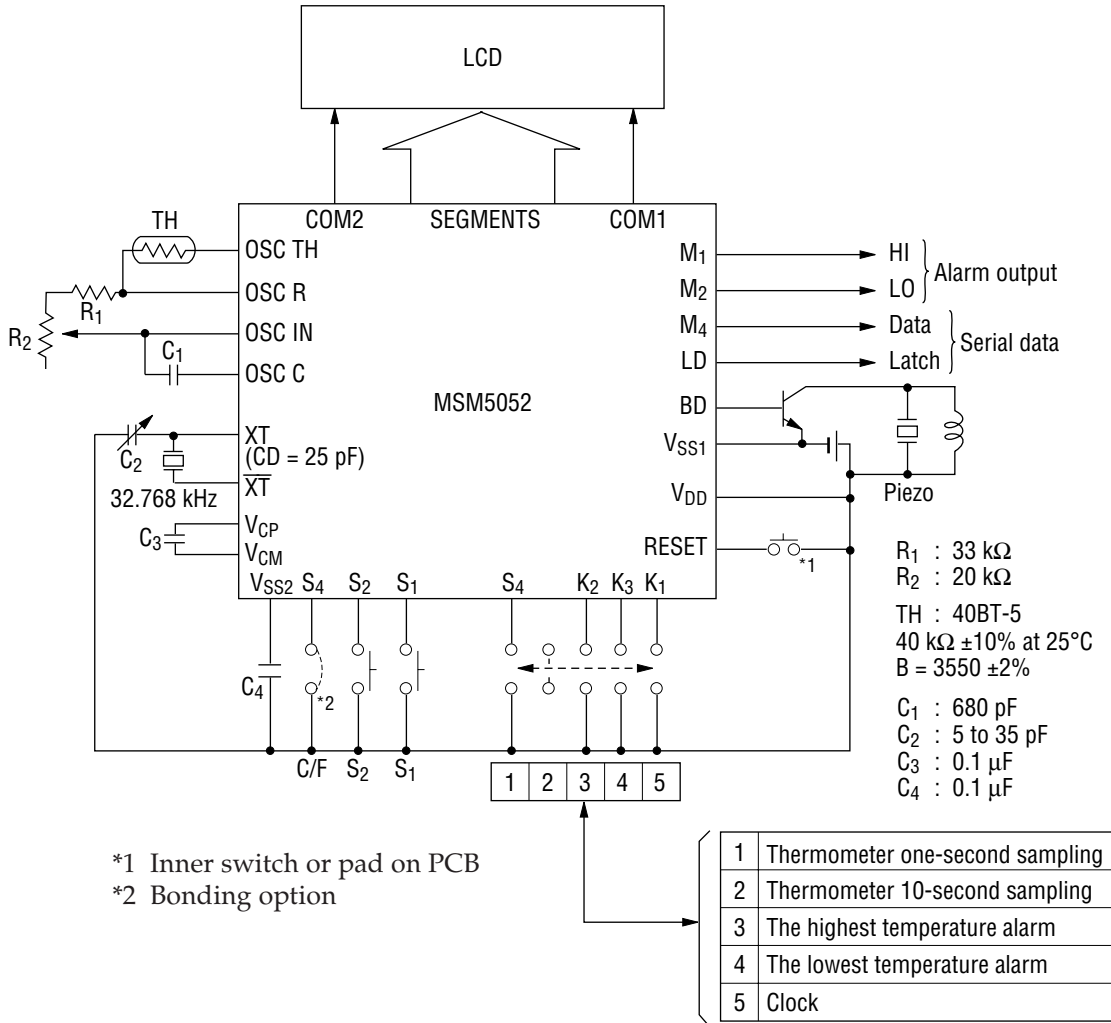

PACKAGE DIMENSIONS

(Unit : mm)

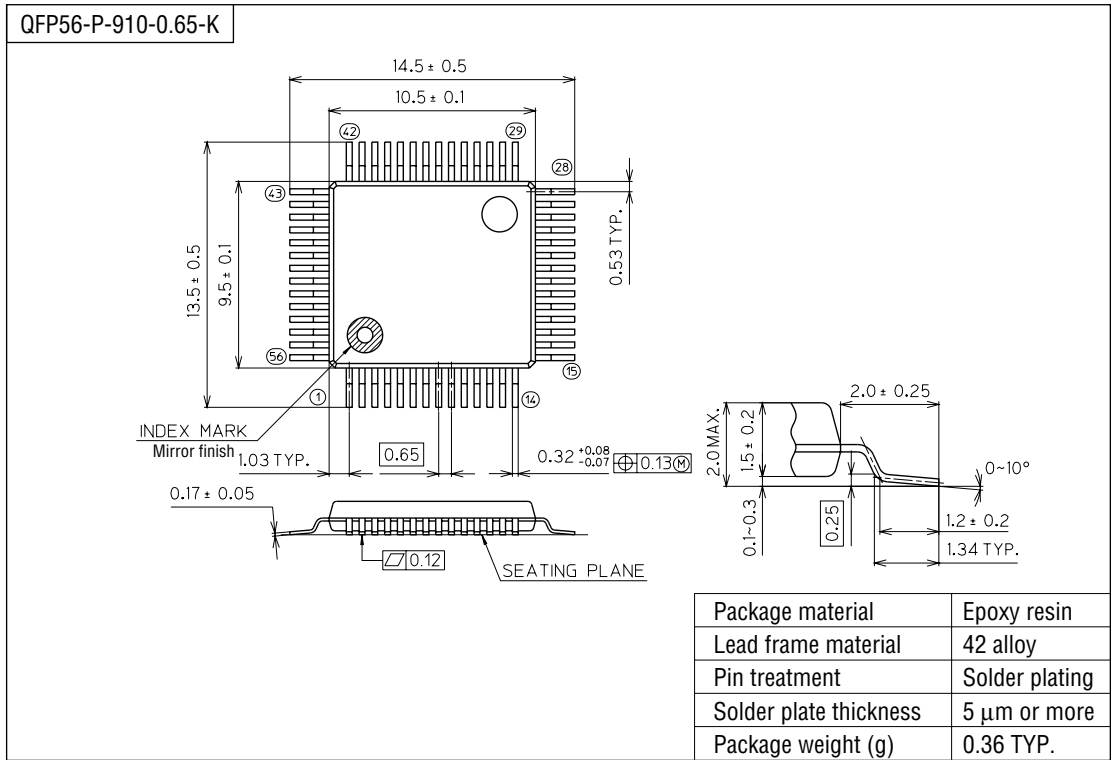

Notes for Mounting the Surface Mount Type Package

The SOP, QFP, TSOP, SOJ, QFJ (PLCC), SHP and BGA are surface mount type packages, which are very susceptible to heat in reflow mounting and humidity absorbed in storage. Therefore, before you perform reflow mounting, contact Oki's responsible sales person for the product name, package name, pin number, package code and desired mounting conditions (reflow method, temperature and times).

(Unit : mm)

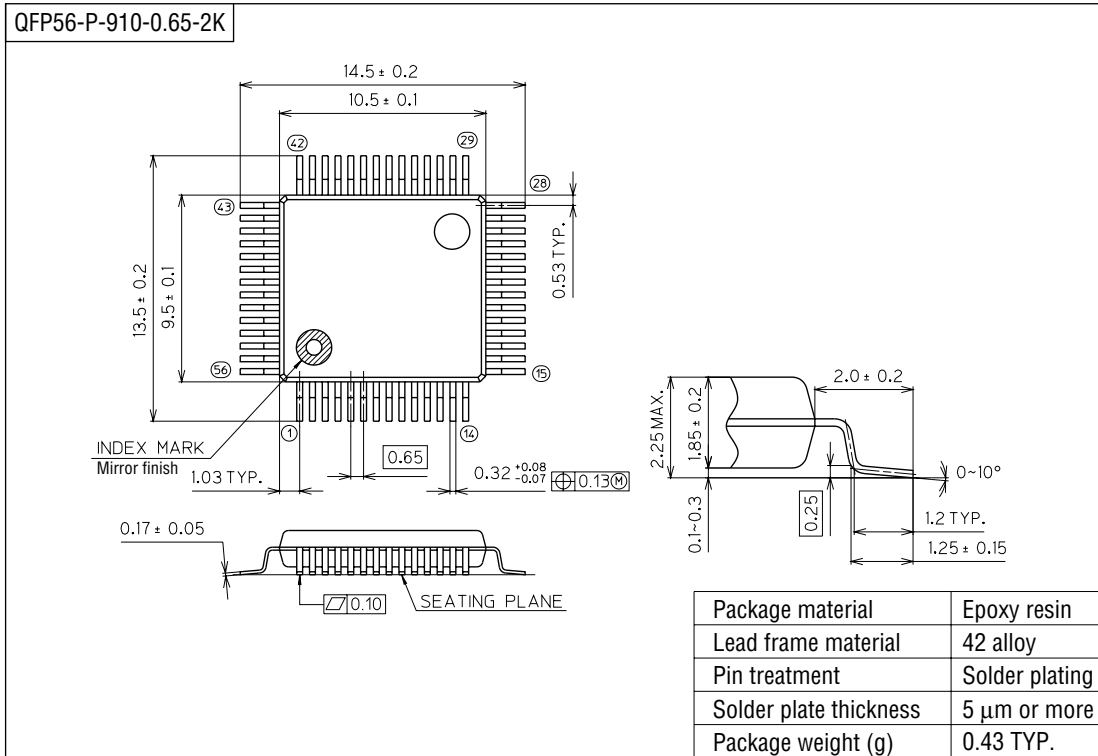

Notes for Mounting the Surface Mount Type Package

The SOP, QFP, TSOP, SOJ, QFJ (PLCC), SHP and BGA are surface mount type packages, which are very susceptible to heat in reflow mounting and humidity absorbed in storage. Therefore, before you perform reflow mounting, contact Oki's responsible sales person for the product name, package name, pin number, package code and desired mounting conditions (reflow method, temperature and times).

(Unit : mm)

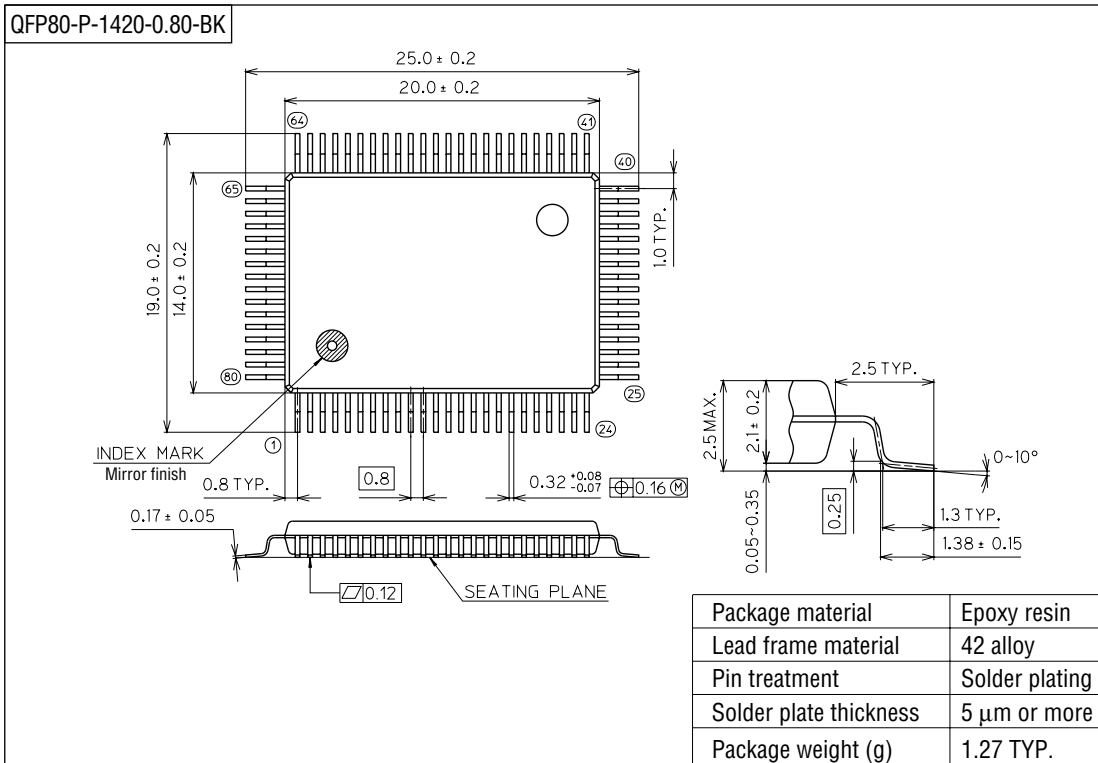

Notes for Mounting the Surface Mount Type Package

The SOP, QFP, TSOP, SOJ, QFJ (PLCC), SHP and BGA are surface mount type packages, which are very susceptible to heat in reflow mounting and humidity absorbed in storage. Therefore, before you perform reflow mounting, contact Oki's responsible sales person for the product name, package name, pin number, package code and desired mounting conditions (reflow method, temperature and times).