

C²MOS DIGITAL INTEGRATED CIRCUIT
SILICON MONOLITHIC

TC7404UBP

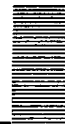

TC7404UBP HEX INVERTING BUFFER

TC7404UBP contains six circuits of inverter type buffers. This has pin to pin compatibility with TC4069UBP and its large output current enables to directly drive one TTL with 5 volt power supply. In addition to its original application as inverters, this can be used as clock drivers and for TTL interface circuits.

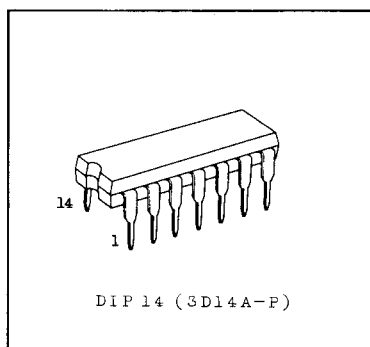

ABSOLUTE MAXIMUM RATINGS

CHARACTERISTIC	SYMBOL	RATING	UNIT
DC Supply Voltage	V _{DD}	V _{SS} -0.5 ~ V _{SS} +20	V
Input Voltage	V _{IN}	V _{SS} -0.5 ~ V _{DD} +0.5	V
Output Voltage	V _{OUT}	V _{SS} -0.5 ~ V _{DD} +0.5	V
DC Input Current	I _{IN}	±10	mA
Power Dissipation	P _D	300	mW
Storage Temperature Range	T _{stg}	-65 ~ 150	°C
Lead Temp./Time	T _{sol}	260°C · 10sec	

PIN ASSIGNMENT

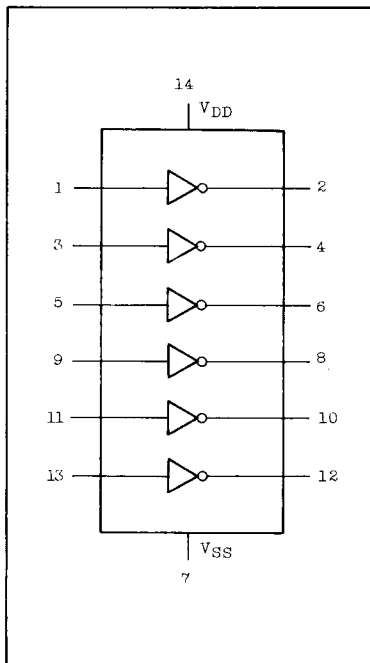

CIRCUIT DIAGRAM

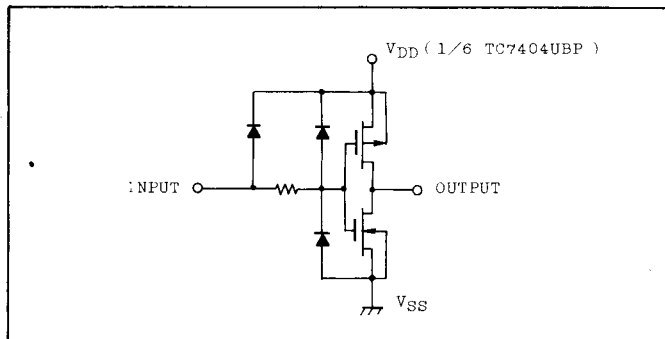

RECOMMENDED OPERATING CONDITIONS (V_{SS}=0V)

CHARACTERISTIC	SYMBOL	MIN.	TYP.	MAX.	UNIT
DC Supply Voltage	V _{DD}	3	-	18	V
Input Voltage	V _{IN}	0	-	V _{DD}	V
Operating Temperature Range	T _{opr}	-40	-	85	°C

TC7404UBP

ELECTRICAL CHARACTERISTICS (V_{SS}=0V)

CHARACTERISTIC	SYMBOL	TEST CONDITIONS	V _{DD} (V)	-40°C		25°C			85°C		UNIT
				MIN.	MAX.	MIN.	TYP.	MAX.	MIN.	MAX.	
High Level Output Voltage	V _{OH}	I _{OUT} < 1μA V _{IN} =V _{SS}	5	4.95	-	4.95	5.00	-	4.95	-	V
			10	9.95	-	9.95	10.00	-	9.95	-	
			15	14.95	-	14.95	15.00	-	14.95	-	
Low Level Output Voltage	V _{OL}	I _{OUT} < 1μA V _{IN} =V _{DD}	5	-	0.05	-	0.00	0.05	-	0.05	V
			10	-	0.05	-	0.00	0.05	-	0.05	
			15	-	0.05	-	0.00	0.05	-	0.05	
High Level Output Current	I _{OH}	V _{OH} =2.5V V _{OH} =9.5V V _{OH} =13.5V V _{IN} =V _{SS}	5	-1.40	-	-1.25	-	-	-1.0	-	mA
			10	-1.40	-	-1.25	-	-	-1.0	-	
			15	-4.00	-	-3.75	-	-	-3.0	-	
Low Level Output Current	I _{OL}	V _{OL} =0.4V V _{OL} =0.5V V _{OL} =1.5V V _{IN} =V _{DD}	5	3.5	-	3.2	-	-	2.5	-	mA
			10	6.0	-	5.0	-	-	3.6	-	
			15	26.0	-	24.0	-	-	18.0	-	
High Level Input Voltage	V _{IH}	V _{OUT} =0.5V V _{OUT} =1.0V V _{OUT} =1.5V I _{OUT} < 1μA	5	4.0	-	4.0	3.0	-	4.0	-	V
			10	8.0	-	8.0	6.5	-	8.0	-	
			15	12.0	-	12.0	9.5	-	12.0	-	
Low Level Input Voltage	V _{IL}	V _{OUT} =4.5V V _{OUT} =9.0V V _{OUT} =13.5V I _{OUT} < 1μA	5	-	1.0	-	2.0	1.0	-	1.0	V
			10	-	2.0	-	2.5	2.0	-	2.0	
			15	-	2.5	-	3.0	2.5	-	2.5	
H.Level Input Current	I _{IH}	V _{IH} =18V	18	-	0.3	-	10 ⁻⁵	0.3	-	1.0	μA
L.Level Input Current	I _{IL}	V _{IL} =0V	18	-	-0.3	-	-10 ⁻⁵	-0.3	-	-1.0	μA
Quiescent Current Consumption	I _{DD}	V _{IN} =V _{SS} , V _{DD} *	5	-	4.0	-	0.002	4.0	-	30	μA
			10	-	8.0	-	0.004	8.0	-	60	
			15	-	16.0	-	0.008	16.0	-	120	

* All valid input combination

SWITCHING CHARACTERISTICS (T_a=25°C, V_{SS}=0V, C_L=50pF)

CHARACTERISTIC	SYMBOL	TEST CONDITIONS	V _{DD} (V)	MIN.	TYP.	MAX.	UNIT
			10	-	65	200	
			15	-	50	160	
Output Fall Time	t _{THL}		5	-	100	200	ns
			10	-	50	100	
			15	-	40	80	

TC7404UBP

SWITCHING CHARACTERISTICS (Ta=25°C, VSS=0V, CL=50pF)

CHARACTERISTIC	SYMBOL	TEST CONDITIONS	VDD (V)	MIN.	TYP.	MAX.	UNIT
(Low-High) Propagation Delay Time	t _{pLH}		5	-	80	150	ns
			10	-	40	100	
			15	-	35	80	
(High-Low) Propagation Delay Time	t _{pHL}		5	-	50	150	ns
			10	-	30	100	
			15	-	25	80	
Input Capacity	C _{IN}			-	15	-	pF

SWITCHING TIME TEST CIRCUIT AND WAVEFORM

