

POWER MANAGEMENT

60mA/110mA/160mA Super Low Dropout CMOS Regulators with Battery Life Extending Shutdown Mode and Adjustable Output

The IMP2070, IMP2071 and IMP2187 feature an adjustable output voltage. Compared to the pin compatible TC1070/1071/1187 devices offered by TelCom Semiconductor. Dropout voltage performance has been improved by up to 40%.

Load regulation and power supply PSRR have been optimized. Load regulation is typically 0.32% and PSRR is 53dB at 1kHz.

A logic input controlled shutdown mode extends system battery life by reducing quiescent current to 0.2µA maximum. The shutdown mode can be initiated by a system microcontroller.

The regulators were designed with ease of use and stability in mind. Stability is guaranteed for 0.47µF and greater load capacitors with an ESR up to 5Ω. Ceramic or tantalum capacitors can be used.

Three devices with different guaranteed output current specifications are available: IMP2070 (60mA), IMP2071 (110mA) and IMP2187 (160mA).

Key Features

- ◆ Pin Compatible with TelCom TC1070/1071/1187
- ◆ Lower Dropout Voltage For Long Battery Life
 - IMP2070: 70mV vs. TelCom TC1070 120mV
 - IMP2071: 160mV vs. TelCom TC1071 250mV
 - IMP2187: 250mV vs. TelCom TC1187 400mV
- ◆ Power Saving Shutdown Mode
 - 0.2µA shutdown current
- ◆ Adjustable Output Voltage
- ◆ Superior Load Regulation
 - 0.32%
- ◆ Long Battery Life
 - 33µA no load ground current
- ◆ Accurate Output Voltage
 - ± 2.5% over temperature
- ◆ Low Drift Output: 40ppm/°C
- ◆ Guaranteed Minimum Output Current
 - IMP2070: 60mA
 - IMP2071: 110mA
 - IMP2187: 160mA
- ◆ Over-Current and Over-Temperature Protection
- ◆ Compact SOT-23A-5 Package

Applications

- ◆ Pagers
- ◆ Cellular/GSM/PHS Phones
- ◆ Instrumentation
- ◆ Wireless Terminals
- ◆ Battery Powered Systems
- ◆ Medical Instruments
- ◆ Linear Post-Regulators

Typical Application

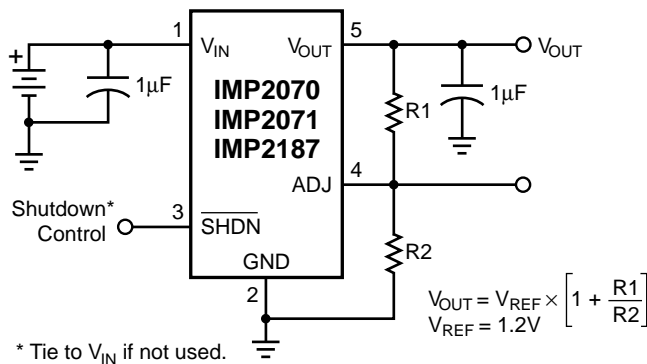

Pin Configuration

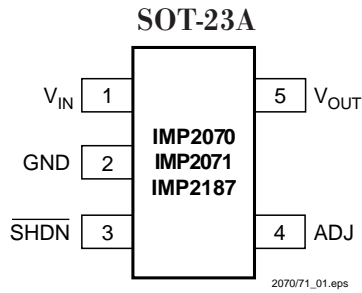

Pin Descriptions

Pin Number	Name	Function
1	V_{IN}	Unregulated supply input.
2	GND	Ground terminal.
3	$\overline{\text{SHDN}}$	Shutdown control input. A shutdown mode is entered when $\overline{\text{SHDN}}$ is a logic LOW. During shutdown the output voltage falls to 0V and quiescent current drops to 2.0 μ A.
4	ADJ	Output voltage adjustment terminal.
5	V_{OUT}	Output voltage.

2070/71_01.eps

Ordering Information

Part Number*	Package	Output Voltage (V)	Output Current (mA)	Shutdown Pin	Adjust Pin	ERROR Flag Output	Reference Bypass Pin	Package Marking			
								A	B	C	D
IMP2070JUK/T	SOT23A-5	Adjustable	60	●	●			J	J	x	x
IMP2071JUK/T	SOT23A-5	Adjustable	110	●	●			K	J	x	x
IMP2187JUK/T	SOT23A-5	Adjustable	160	●	●			L	J	x	x

xx = Date Code

* /T indicates Tape and Reel

2070/71_003.eps

Absolute Maximum Ratings

Input Voltage 7V
 Output Voltage -0.3V to $V_{IN} + 0.3V$
 Maximum Voltage on Any Pin -0.3V to $(V_{IN} + 0.3V)$
 Shutdown Voltage (\overline{SHDN}) $\overline{SHDN} \leq V_{IN} + 0.3V$

These are stress ratings only and functional operation is not implied. Exposure to absolute maximum ratings for prolonged time periods may affect device reliability. All voltages are with respect to ground.

Operating Junction Temperature Range ... $-40^{\circ}\text{C} < T_J < 125^{\circ}\text{C}$
 Storage Temperature -65°C to 150°C
 Power Dissipation Internally limited

Note: T_J = Junction Temperature, T_A = Ambient Temperature

Electrical Characteristics

$V_{IN} = V_{OUT} + 1V$, $I_L = 100\mu\text{A}$, $C_L = 1\mu\text{F}$, $\overline{SHDN} > V_{IH}$, $T_A = 25^{\circ}\text{C}$, unless otherwise noted. **Bold/blue** specifications apply for junction temperature range $-40^{\circ}\text{C} < T_J < 125^{\circ}\text{C}$.

Parameter	Symbol	Conditions	Min	Typ	Max	Units
Input Voltage Range	V_{IN}	$0^{\circ}\text{C} < T_J < 125^{\circ}\text{C}$			6.50	V
		$-40^{\circ}\text{C} < T_J < 125^{\circ}\text{C}$			6.50	
Maximum Output Current	I_{OMAX}	IMP2070	60			mA
		IMP2071	110			
		IMP2187	160			
Adjustable Output Voltage Range			V_{REF}		5.5	V
Reference Voltage	V_{REF}		1.165	1.20	1.235	V
Dropout Voltage (Note 1)	$V_{IN} - V_O$	$I_L = 100\mu\text{A}$		1		mV
		$I_L = 20\text{mA}$		17	23	
		$I_L = 50\text{mA}$		60	70	
		$I_L = 100\text{mA}$ (IMP2070, IMP2187)		90	160	
		$I_L = 150\text{mA}$ (IMP2187)		143	250	
Quiescent Current (Ground Current)		No load		33	50	μA
Shutdown Supply Current	I_{INSD}	$\overline{SHDN} = 0V$ $T_J \leq 25^{\circ}\text{C}$		0.2	2	μA
Output Temperature Coefficient				40		ppm/ $^{\circ}\text{C}$
Thermal Regulation				0.04		%/W
Line Regulation		$V_R + 1V \leq V_{IN} \leq 6V$		0.0375	0.35	%

- Notes:
- Dropout Voltage is defined as the difference between IN and OUT when V_R drops 2% below its nominal value.
 - Specifications which would otherwise be affected by self-heating of the die are tested at a constant die temperature by using low duty cycle pulse testing.
 - PSRR guaranteed by design.

2070/71_102a.eps

Electrical Characteristics

$V_{IN} = V_{OUT} + 1V$, $I_L = 100\mu A$, $C_L = 1\mu F$, $\overline{SHDN} > V_{IH}$, $T_A = 25^\circ C$, unless otherwise noted. **Bold/blue** specifications apply for junction temperature range of $-40^\circ C < T_J < 125^\circ C$.

Parameter	Symbol	Conditions	Min	Typ	Max	Units
Load Regulation: IMP2070		$I_L = 100\mu A$ to 50mA		0.32	2.0	%
IMP2071		$I_L = 100\mu A$ to 100mA		0.32	2.0	
IMP2187		$I_L = 100\mu A$ to 150mA		0.32	3.0	
Thermal Shutdown Die Temperature				150		$^\circ C$
Thermal Shutdown Hysteresis				12		$^\circ C$
Ripple Rejection	PSRR	$V_{IN} \geq (V_O + 1V) \pm 0.25V$ $C_O = 3.3\mu F$ ceramic				dB
				Freq. = 1kHz	58	
				Freq. = 10kHz	45	
				Freq. = 1MHz	34	
Output Noise		300Hz to 50kHz $I_L = 50mA$ (IMP2070) $I_L = 100mA$		280		μV_{RMS}
\overline{SHDN} Input HIGH Threshold		$2.5V \leq V_{IN} \leq 6.5V$	45			% of V_{IN}
\overline{SHDN} Input LOW Threshold		$2.5V \leq V_{IN} \leq 6.5V$			15	% of V_{IN}
\overline{ERROR} Flag Minimum Supply Voltage			1.5			V
\overline{ERROR} Flag Threshold Voltage		V_{TH}		$0.95V_R$		V
\overline{ERROR} Flag Hysteresis		V_{HYS}		50		mV
\overline{ERROR} Flag Output Low Voltage		$I_{\overline{ERROR}} = 1mA$		75	400	mV
Reverse Current into V_{OUT}		$V_{(IN)} < V_{(OUT)}$ $\overline{SHDN} = HIGH = V_{IN}$		2.0		mA
		$V_{(IN)} < V_{(OUT)}$ $\overline{SHDN} = LOW$		2.7		μA
Output Current Limit				350	600	mA
Adjust Input Leakage Current	I_{ADJ}			50		pA

- Notes: 1. Dropout Voltage is defined as the difference between IN and OUT when V_R drops 2% below its nominal value.
 2. Specifications which would otherwise be affected by self-heating of the die are tested at a constant die temperature by using low duty cycle pulse testing.
 3. PSRR guaranteed by design.

2070/71_102b.eps

Typical Characteristics

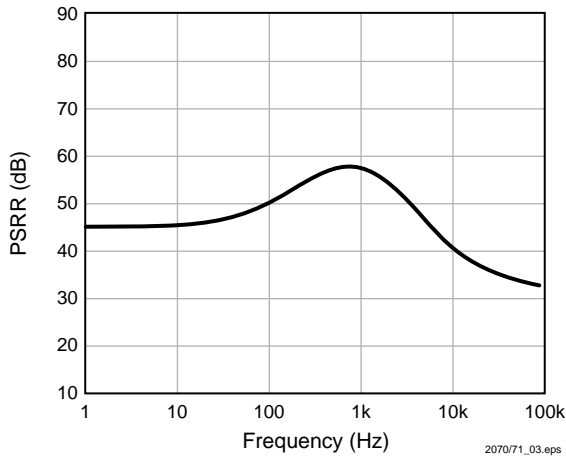

Figure 1. IMP2070 PSRR at $I_{LOAD} = 100mA$

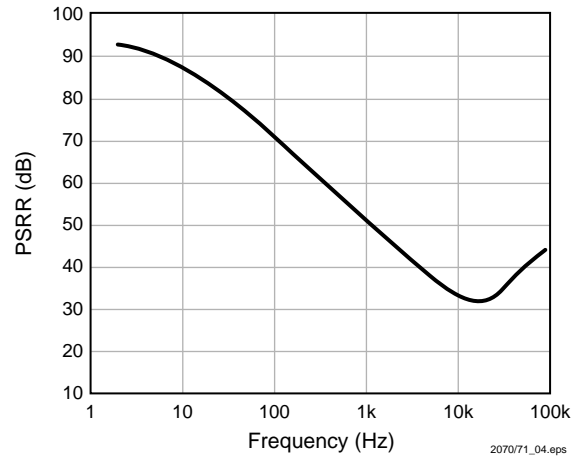

Figure 2. IMP2070 PSRR at $I_{LOAD} = 1mA$

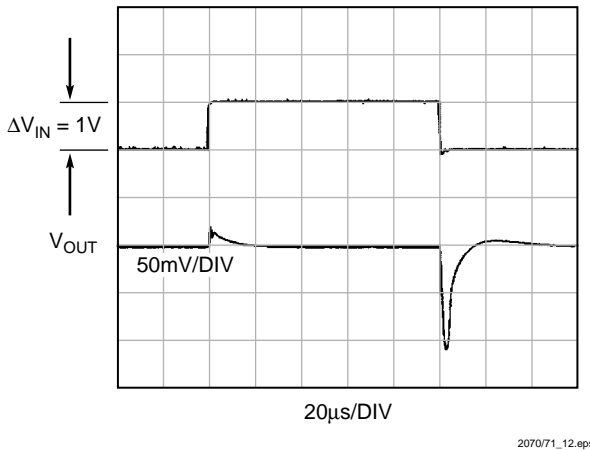

Figure 3. Line Transient Response

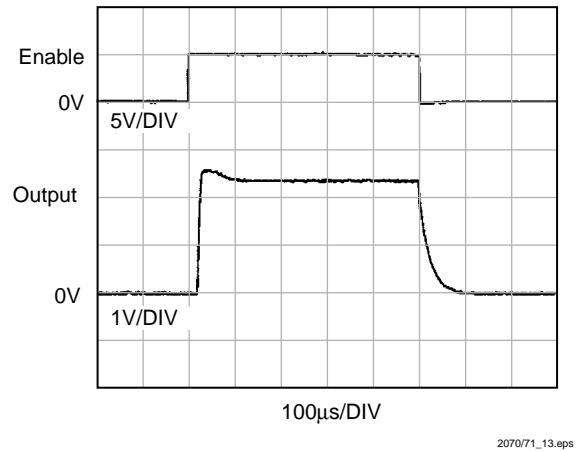

Figure 4. Enable Input Response

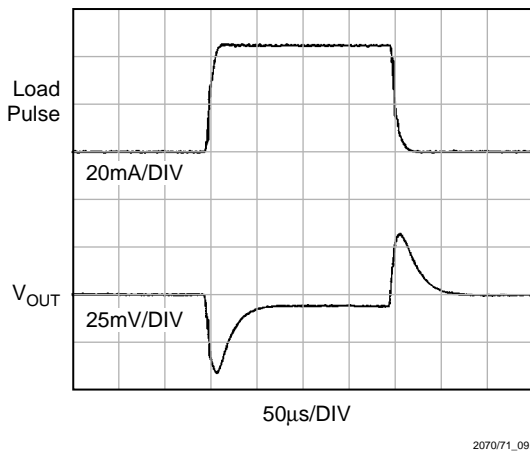

Figure 5. Load Transient Response (50mA Step)

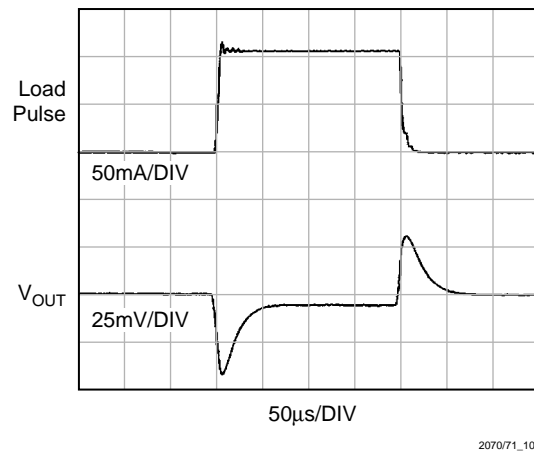
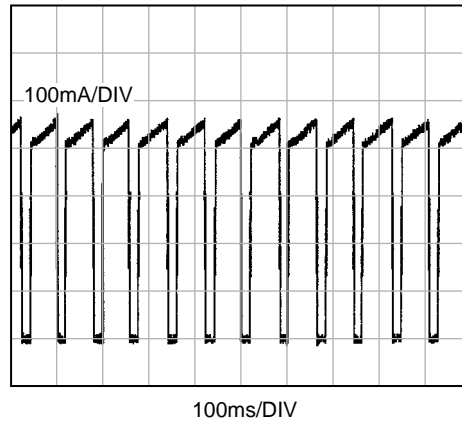

Figure 6. Load Transient Response (100mA Step)

Typical Characteristics



207071_11.eps

Figure 7. Output Current Limit

Application Information

The IMP2070, IMP2071 and IMP2187 have been designed to offer exceptionally low dropout voltage, adjustable outputs, superior load regulation and minimum quiescent power.

Shutdown Mode

A battery-life-extending mode is available. Through the active LOW shutdown pin, $\overline{\text{SHDN}}$, the regulator can be enabled or turned off. The regulator is shutdown (turned off) when $\overline{\text{SHDN}}$ is LOW and enabled (turned on) when $\overline{\text{SHDN}}$ is HIGH.

The shutdown signal can be supplied from a CMOS gate or from an I/O port of a microcontroller.

During shutdown, the output voltage falls to 0V and the supply current is typically 200nA.

If the shutdown mode is not needed, $\overline{\text{SHDN}}$ should be connected directly to the regulator input voltage pin.

Output Voltage Adjustment

Adjust Input

The output voltage setting is determined by the values of R1 and R2 (Figure 8). These resistors should be between 470kΩ and 3MΩ to minimize current.

The output voltage setting is calculated using the following equation.

$$V_{\text{OUT}} = V_{\text{REF}} \times \left[1 + \frac{R1}{R2} \right]$$

The voltage adjustment range of the IMP2070, IMP2071, and IMP2187 is from V_{REF} to $(V_{\text{IN}} - 0.05\text{V})$. A small capacitor (100pF to 0.01μF) may be added to the ADJ input to further reduce output noise. A typical 2.45V battery operated supply is shown in Figure 8.

Output Capacitor

The IMP2070, IMP2071 and IMP2187 were designed for stable operation with a wide range of capacitor values and type. The output capacitor should be above 0.47μF. A 1μF value is recommended. Ceramic or tantalum capacitors are suitable with an ESR up to 5Ω.

Thermal Shutdown

An on-chip thermal protection circuit shuts the LDO regulator off when the die temperature exceeds 150°C. There is a built in 12°C hysteresis. The regulator will remain off until the die temperature drops to approximately to 138°C.

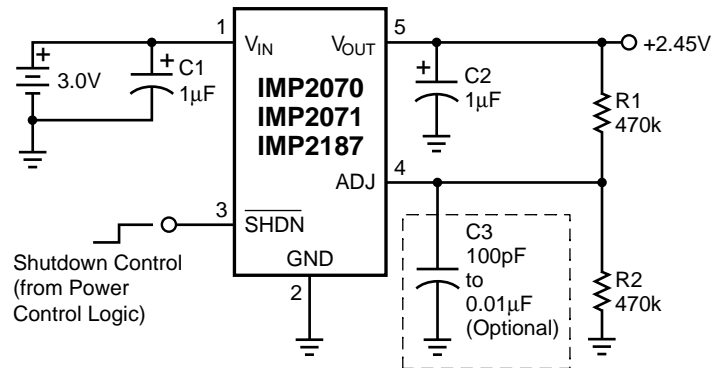

207071_12.eps

Figure 8. 2.45 Battery-Operated Supply