

■ Hybrid Voltage Regulators (Linear Type)

Type No.	Maximum Ratings (Ta=25°C)					Electrical Characteristics (Ta=25°C)						Fig. No.	Remarks
	V _{IN} (V)	I _{out} (A)	P _c (W)	T _{op} (°C)	T _{stg} (°C)	V _{out} (V)	V _{DIF} (V)	ΔV _o /ΔT (mV/°C)	Line Reg. (mV)	Load Reg. (mV)	Ripple Rej. (dB)		
STR90050	25	2	50	-20~+100 (T _c)	-30~+125	5±0.1	1.0	±0.5	10	40	54	5	
90090						9±0.1		±1.0	15	60			
90120	30	12±0.2	±1.5	20	80								
90150		15±0.2											

Type No.	Maximum Ratings (Ta=25°C)					Electrical Characteristics (Ta=25°C)						Fig. No.	Remarks
	V _{IN} (V)	I _{out} (A)	P _d (W)	T _{op} (°C)	T _{stg} (°C)	V _{out} (V)	V _{DIF} (V)	ΔV _o /ΔT (mV/°C)	Line Reg. (mV)	Load Reg. (mV)	Ripple Rej. (dB)		
SI-3052V	15	2.0	50	-20~+100 (T _c)	-30~+125	5±0.1	1.0	±0.5	10	40	54	6	
-3122V	12±0.2					±1.5		20	80				
-3152V	15±0.2												
STR9005	15	4.0	75	-20~+100 (T _c)	-30~+125	5±0.1	1.0	±0.5	10	40	54	1	
9012	12±0.2					±1.5		30	80				
9015	15±0.2							50	100				
SI-3052P	30	2.0	50	-20~+80	-30~+125	5±0.1	3.0	±0.5	2	40	60	6	
-3122P	12±0.2					±1.5		10	80				
-3152P	15±0.2												
-3242P	24±0.2									±2.5			

■ Hybrid Voltage Regulators (Chopper Type)

Type No.	Maximum Ratings (Ta=25°C)					Electrical Characteristics (Ta=25°C)						Fig. No.	Remarks
	V _{IN} (V)	I _{out} (A)	P _d (W)	T _{op} (°C)	T _{stg} (°C)	V _{out} (V)	V _{IN} (V)	ΔV _o /ΔT (mV/°C)	Line Reg. (mV)	Load Reg. (mV)	Ripple Rej. (dB)		
STR2005	45	2.0	75	-20~+100	-20~+125	5.1±0.1	11~40	—	50	100	45	1	
2012						12±0.2	18~45						
2013						13±0.2	19~45						
2015						15±0.2	21~45						
2024						24±0.3	30~50		80				

■ Hybrid Stepping Motor Drivers

Type No.	Maximum Ratings (Ta=25°C)					Electrical Characteristics (Ta=25°C)						Fig. No.	Remarks
	V _{cc} (V) (surge)	I _L (A)	T _j (°C)	T _{op} (°C)	T _{stg} (°C)	V _{cc} (V)			I _o (A)	I _{in} (mA)			
						min	typ	max					
SI-7200E	70	1.2	125	-20~+80	-30~+100	20	30	50	1.0	1.6	7	Bipolar drive	
SI-7230E		3.0							2.5				
SI-7115B	40	1.7	125	-20~+80	-30~+100	20	24	30	1.5	5	8	Unipolar drive	
SI-7300A	48	1.7	125	-20~+80	-30~+100	15	30	42	1.5	45	9	Unipolar drive	
SI-7330A	42	3.2	125	-20~+80	-30~+100	15	30	35	3.0	45	10	Unipolar drive	
SI-7500A	40	1.2	125	-20~+80	-30~+100	17	24	30	1.0	0.21	10	Unipolar drive	
SI-7200M	50	1.2	125	-20~+80	-30~+100	15	30	40	1.0	1.6	9	Bipolar drive	
SI-7230M	70	3.2	125	-20~+80	-30~+100	15(V _{CC1}) 4.5(V _{CC2})	30(V _{CC1}) 5(V _{CC2})	45(V _{CC1}) 5.5(V _{CC2})	0.2~3(I _o) 0.58(I _{oM})	1.6	10	Bipolar drive	

Hybrid Stepping Motor Drivers

Type No.	Maximum Ratings (Ta=25°C)							Electrical Characteristics (Ta=25°C)			
	Power Stage	MOS-FET	Control Stage	TTL	VREF	Io	Tstg	DC Characteristics			
	Vcc(V)	Vbss(V)	Vs(V)	VIN(V)	(V)	(A)	(°C)	Control Stage		Control Stage	
	Is(mA)		Vs(V)		typ		min		typ		max
SLA7020M	46	100	32	7	2	1.5	-40~+150°C	10	10	19	30

Electrical Characteristics (Ta=25°C)										Remarks	Fig. No.		
DC Characteristics									AC Characteristics				
MOS-FET	MOS-FET	TTL	TTL	TTL	TTL	TTL	TTL	MOS-FET	Switching Time				
VDS(ON)(V)	Iloss(mA)	IiH(μA)	IiL(mA)	Vih(V) at ID=1A	Vil(V) at VDS=100V	Vih(V) at VDS=100V	Vil(V) at ID=1A	VSD(V)	tr(μs)	tstg(μs)	tf(μs)		
max	max	max	max	min	max	min	max	max	typ	typ	typ		
0.6	4	40	-0.8	2.0	0.8	2.0	0.8	1.1	0.5	0.7	0.1	MOS-FET in Power Stage	11

Outline Drawings (Dimensions in mm)

Fig 1

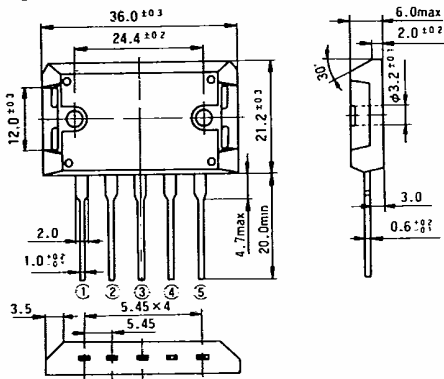

Fig 2

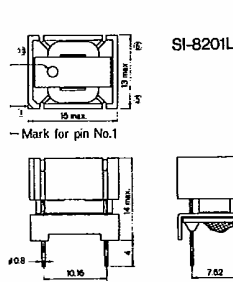

Fig 3

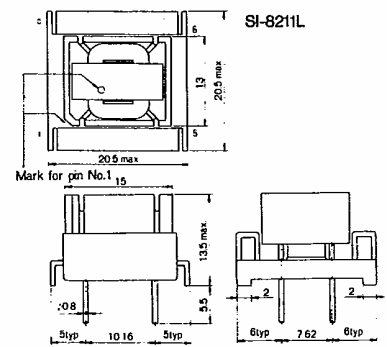

Fig 4

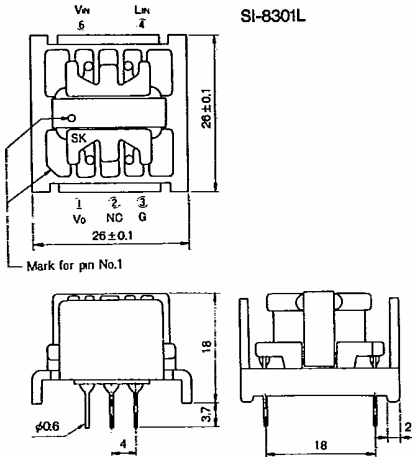

Fig 5

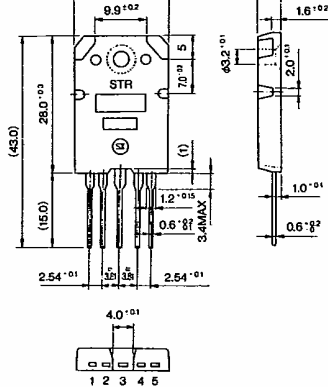

Fig 6 MT-100(TO-3P)

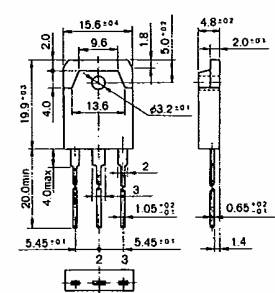

Fig 7

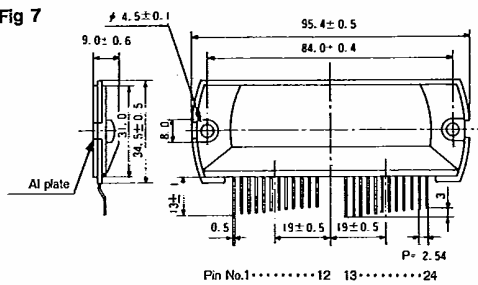

Fig 8

