

TENTATIVE TOSHIBA MOS DIGITAL INTEGRATED CIRCUIT SILICON GATE CMOS
131,072-WORD BY 8-BIT CMOS STATIC RAM

DESCRIPTION

The TC558128BJI/BFTI is a 1,048,576-bit high-speed static random access memory (SRAM) organized as 131,072 words by 8 bits. Fabricated using CMOS technology and advanced circuit techniques to provide high speed, it operates from a single 5 V power supply. There are two control inputs. Chip enable (\overline{CE}) can be used to place the device in a low-power mode, and output enable (\overline{OE}) provides fast memory access. This device is well suited to cache memory applications where high-speed access and high-speed storage are required. All inputs and outputs are directly TTL compatible. The TC558128BJI/BFTI is available in a plastic 32-pin SOJ (400 mil width) and TSOP packages for high density surface assembly. The TC558128BJI/BFTI guarantees -40° to 85°C operating temperature so it is suitable for use in wide operating temperature system.

FEATURES

- Fast access time (the following are maximum values)
 - TC558128BJI/BFTI-12: 12 ns
 - TC558128BJI/BFTI-15: 15 ns
- Low-power dissipation (the following are maximum values)

Cycle Time	12	15	20	25	30	ns
Operation (max)	200	170	140	130	120	mA

Standby: 1 mA (both devices)
- Single power supply voltage :
 - TC558128BJI/BFTI-12 : $5\text{V} \pm 5\%$
 - TC558128BJI/BFTI-15 : $5\text{V} \pm 10\%$
- Fully static operation
- All inputs and outputs are TTL compatible
- Output buffer control using \overline{OE}
- Package:
 - SOJ32-P-400-1.27A(BJI) (Weight: 1.22 g typ)
 - TSOP II 32-P-400-0.80C(BFTI) (Weight: 0.34 g typ)

PIN ASSIGNMENT

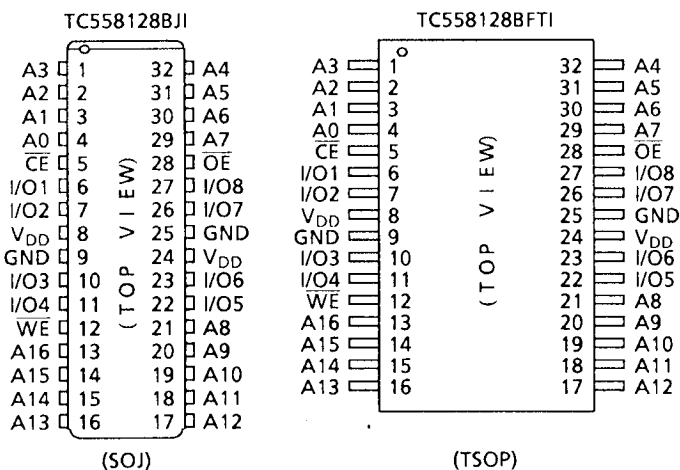

PIN NAMES

A0 to A16	Address Inputs
I/O1 to I/O8	Data Inputs/Outputs
\overline{CE}	Chip Enable
\overline{WE}	Write Enable Input
\overline{OE}	Output Enable
V_{DD}	Power (+ 5 V)
GND	Ground

961001EBA1

● TOSHIBA is continually working to improve the quality and the reliability of its products. Nevertheless, semiconductor devices in general can malfunction or fail due to their inherent electrical sensitivity and vulnerability to physical stress. It is the responsibility of the buyer, when utilizing TOSHIBA products, to observe standards of safety, and to avoid situations in which a malfunction or failure of a TOSHIBA product could cause loss of human life, bodily injury or damage to property. In developing your designs, please ensure that TOSHIBA products are used within specified operating ranges as set forth in the most recent products specifications. Also, please keep in mind the precautions and conditions set forth in the TOSHIBA Semiconductor Reliability Handbook.

● The products described in this document are subject to foreign exchange and foreign trade control laws.

● The information contained herein is presented only as a guide for the applications of our products. No responsibility is assumed by TOSHIBA CORPORATION for any infringements of intellectual property or other rights of the third parties which may result from its use. No license is granted by implication or otherwise under any intellectual property or other rights of TOSHIBA CORPORATION or others.

● The information contained herein is subject to change without notice.

BLOCK DIAGRAM

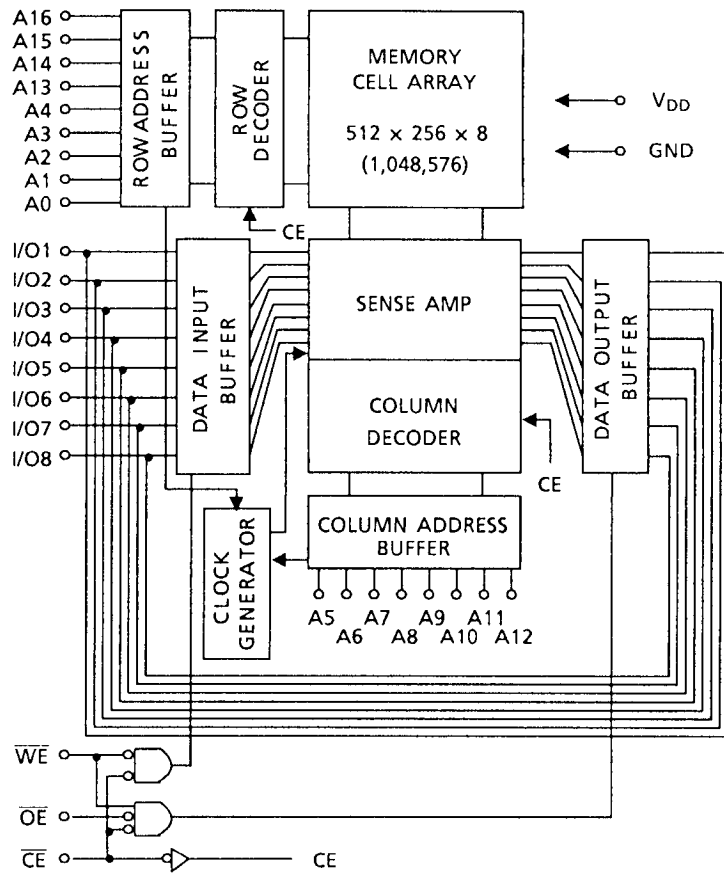

MAXIMUM RATINGS

SYMBOL	RATING	VALUE	UNIT
V _{DD}	Power Supply Voltage	- 0.5 to 7.0	V
V _{IN}	Input Terminal Voltage	- 2.0 * to 7.0	V
V _{I/O}	Input/Output Terminal Voltage	- 0.5 * to V _{DD} + 0.5	V
P _D	Power Dissipation	1.1	W
T _{solder}	Soldering Temperature (10 s)	260	°C
T _{strg}	Storage Temperature	- 65 to 150	°C
T _{opr}	Operating Temperature	- 40 to 85	°C

*: I/O pins : -2.0 V with a pulse width of 20% · Cycle Time min(4 ns max)
 Other pins : -2.5 V with a pulse width of 20% · Cycle Time min(4 ns max)

DC RECOMMENDED OPERATING CONDITIONS (Ta = -40° to 85°C)

SYMBOL	PARAMETER	MIN	TYP	MAX	UNIT
V _{DD}	Power Supply Voltage	4.5 (4.75)	5.0	5.5 (5.25)	V
V _{IH}	Input High Voltage	2.2	-	V _{DD} + 0.5	V
V _{IL}	Input Low Voltage	- 0.5 *	-	0.8	V

*: I/O pins : -1.5 V with a pulse width of 20% · Cycle Time min(4 ns max)
 Other pins : -2.0 V with a pulse width of 20% · Cycle Time min(4 ns max)

DC CHARACTERISTICS (Ta = -40° to 85°C, -12:V_{DD} = 5V ± 5%, -15:V_{DD} = 5V ± 10%)

SYMBOL	PARAMETER	TEST CONDITION	MIN	TYP	MAX	UNIT	
I _{IL}	Input Leakage Current	V _{IN} = 0 V to V _{DD}	-	-	± 10	μA	
I _{LO}	Output Leakage Current	$\overline{CE} = V_{IH}$ or $\overline{WE} = V_{IL}$ or $\overline{OE} = V_{IH}$ V _{OUT} = 0 V to V _{DD}	-	-	± 10	μA	
I _{OH}	Output High Current	V _{OH} = 2.4 V	- 4	-	-	mA	
I _{OL}	Output Low Current	V _{OL} = 0.4 V	8	-	-	mA	
I _{DDO}	Operating Current	$\overline{CE} = V_{IL}$, I _{out} = 0 mA Other Inputs = V _{IH} or V _{IL}	tcycle = 12 ns	-	-	200	mA
			tcycle = 15 ns	-	-	170	
			tcycle = 20 ns	-	-	140	
			tcycle = 25 ns	-	-	130	
			tcycle = 30 ns	-	-	120	
I _{DDs1}	Standby Current	$\overline{CE} = V_{IH}$, Other Inputs = V _{IH} or V _{IL}	-	-	30	mA	
I _{DDs2}		$\overline{CE} = V_{DD} - 0.2 V$ Other Inputs = V _{DD} - 0.2 V or 0.2 V	-	-	1		

CAPACITANCE (Ta = 25°C, f = 1.0 MHz)

SYMBOL	PARAMETER	TEST CONDITION	MAX	UNIT
C _{IN}	Input Capacitance	V _{IN} = GND	6	pF
C _{I/O}	Input/Output Capacitance	V _{I/O} = GND	8	pF

Note: This parameter is periodically sampled and is not 100% tested.

OPERATING MODE

MODE	\overline{CE}	\overline{OE}	\overline{WE}	I/O1 to I/O8	POWER
Read	L	L	H	Output	I_{DD0}
Write	L	x	L	Input	I_{DD0}
Outputs Disable	L	H	H	High Impedance	I_{DD0}
Standby	H	x	x	High Impedance	I_{DD5}

X: Don't care

AC CHARACTERISTICS ($T_a = -40^\circ$ to 85°C ^(Note 1), -12: $V_{DD} = 5V \pm 5\%$, -15: $V_{DD} = 5V \pm 10\%$)

READ CYCLE

SYMBOL	PARAMETER	TC558128BJI/BFTI-12		TC558128BJI/BFTI-15		UNIT
		MIN	MAX	MIN	MAX	
t_{RC}	Read Cycle Time	12	-	15	-	ns
t_{ACC}	Address Access Time	-	12	-	15	
t_{CO}	Chip Enable Access Time	-	12	-	15	
t_{OE}	Output Enable Access Time	-	6	-	8	
t_{OH}	Output Data Hold Time from Address Change	5	-	5	-	
t_{COE}	Output Enable Time from Chip Enable	5	-	5	-	
t_{OEE}	Output Enable Time from Output Enable	1	-	1	-	
t_{COD}	Output Disable Time from Chip Enable	-	6	-	8	
t_{ODO}	Output Disable Time from Output Enable	-	6	-	8	

WRITE CYCLE

SYMBOL	PARAMETER	TC558128BJI/BFTI-12		TC558128BJI/BFTI-15		UNIT
		MIN	MAX	MIN	MAX	
t_{WC}	Write Cycle Time	12	-	15	-	ns
t_{WP}	Write Pulse Width	8	-	9	-	
t_{CW}	Chip Enable to End of Write	10	-	12	-	
t_{AW}	Address Valid to End of Write	10	-	12	-	
t_{AS}	Address Setup Time	0	-	0	-	
t_{WR}	Write Recovery Time	0	-	0	-	
t_{DS}	Data Setup Time	6	-	8	-	
t_{DH}	Data Hold Time	0	-	0	-	
t_{OEW}	Output Enable Time from Write Enable	1	-	1	-	
t_{ODW}	Output Disable Time from Write Enable	-	6	-	8	

AC TEST CONDITIONS

Input Pulse Level	3.0 V, 0.0 V
Input Pulse Rise and Fall Time	3 ns
Input timing Measurement Reference Level	1.5 V
Output Timing Measurement Reference Level	1.5 V
Output Load	Fig. 1

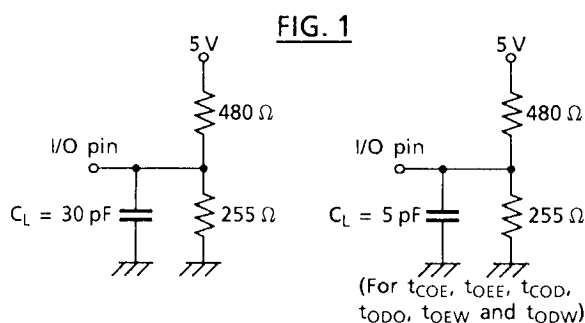

TIMING DIAGRAMS

READ CYCLE (See Note 2)

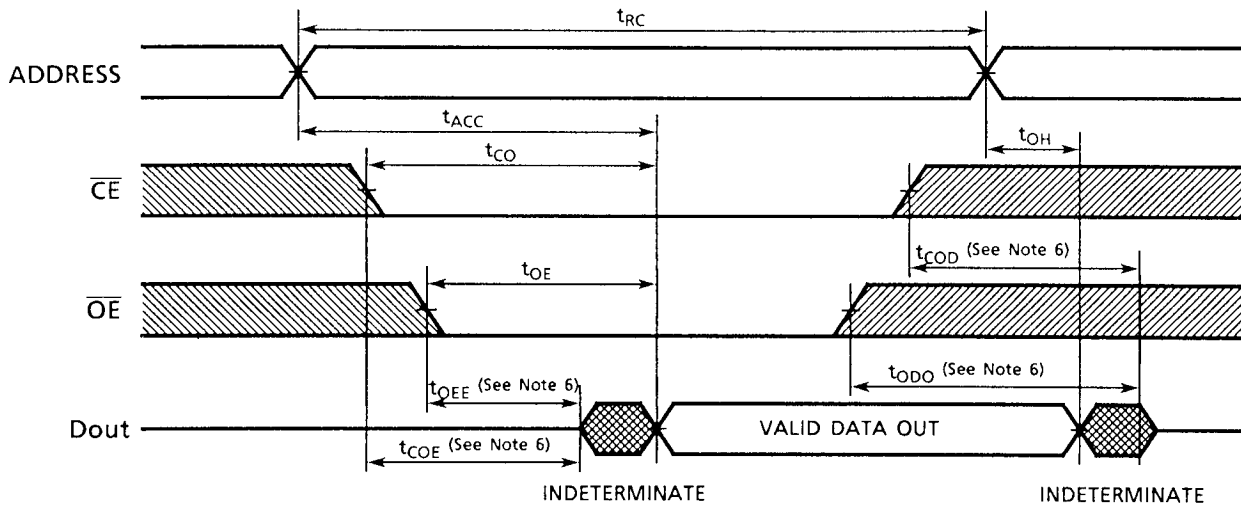

WRITE CYCLE 1 (\overline{WE} CONTROLLED) (See Note 5)

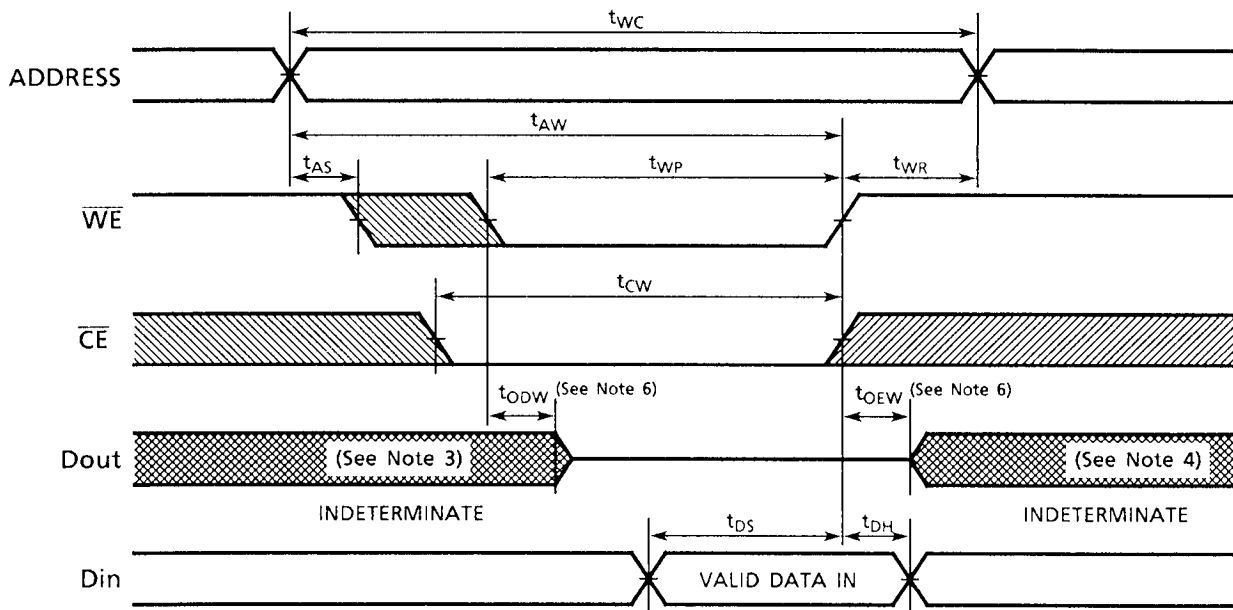

WRITE CYCLE 2 (\overline{CE} CONTROLLED) (See Note 5)

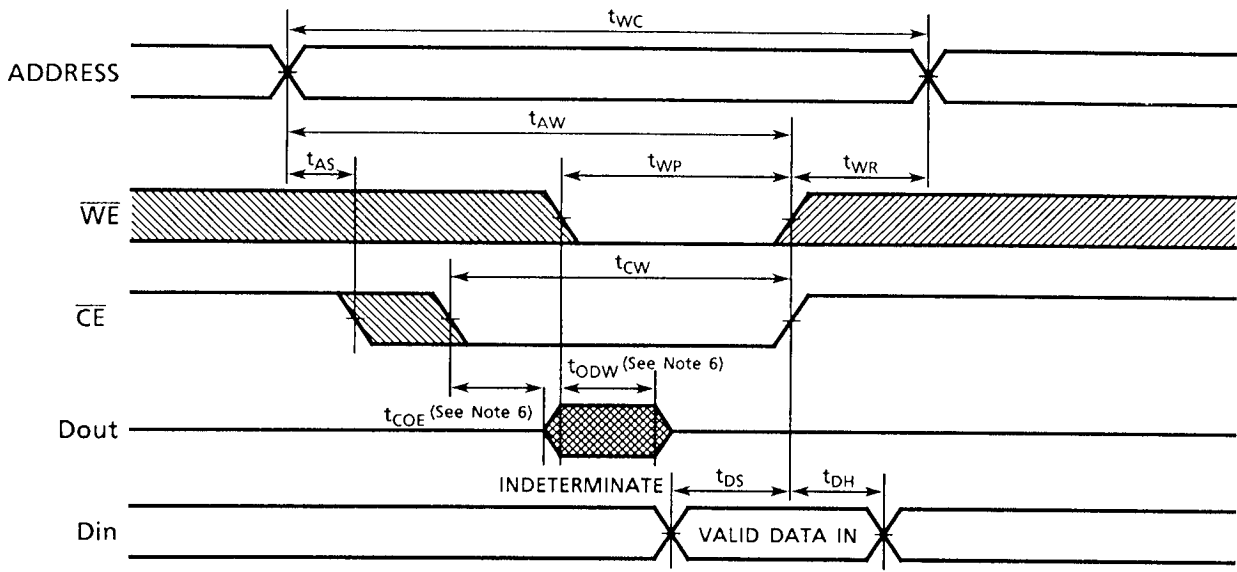

Note: (1) Operating temperature (T_a) is guaranteed for transverse air flow exceeding 400 linear feet per minute.

(2) \overline{WE} remains HIGH for the Read Cycle.

(3) If \overline{CE} goes LOW coincident with or after \overline{WE} goes LOW, the outputs will remain at high impedance.

(4) If \overline{CE} goes HIGH coincident with or before \overline{WE} goes HIGH, the outputs will remain at high impedance.

(5) If \overline{OE} is HIGH during the write cycle, the outputs will remain at high impedance.

(6) The parameters specified below are measured using the load shown in Fig. 1.

(A) $t_{COE}, t_{OEE}, t_{OEW}$ Output Enable Time

(B) $t_{COD}, t_{ODO}, t_{ODW}$ Output Disable Time

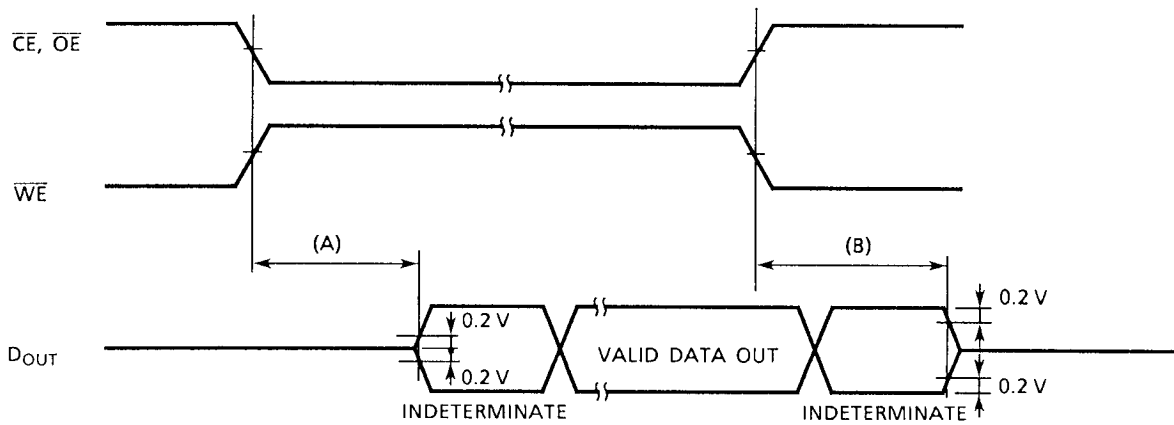

PACKAGE DIMENSIONS

Plastic SOJ (SOJ32-P-400-1.27A)

Units in mm

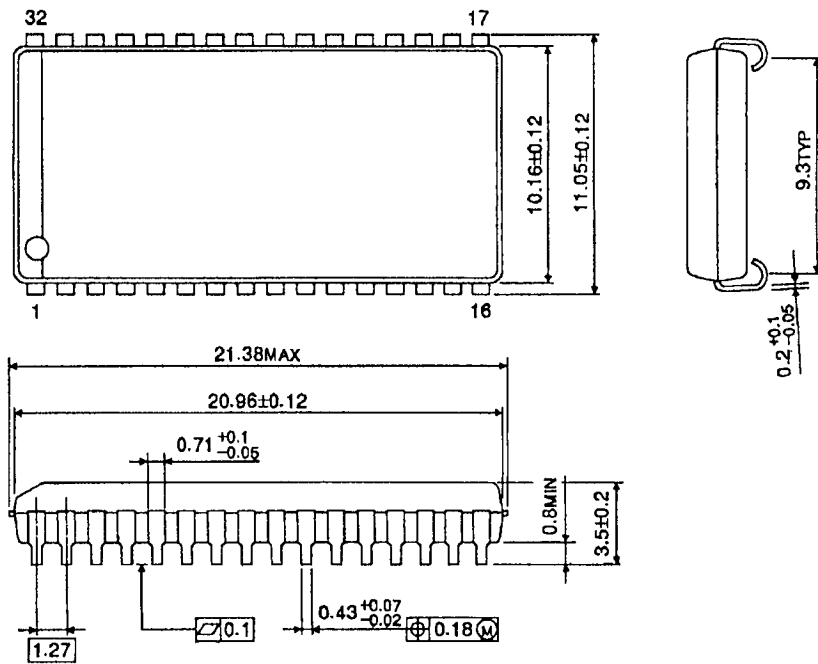

Weight: 1.22 g (typ)

PACKAGE DIMENSIONS

Plastic TSOP (TSOPII 32-P-400-0.80C)

Units in mm

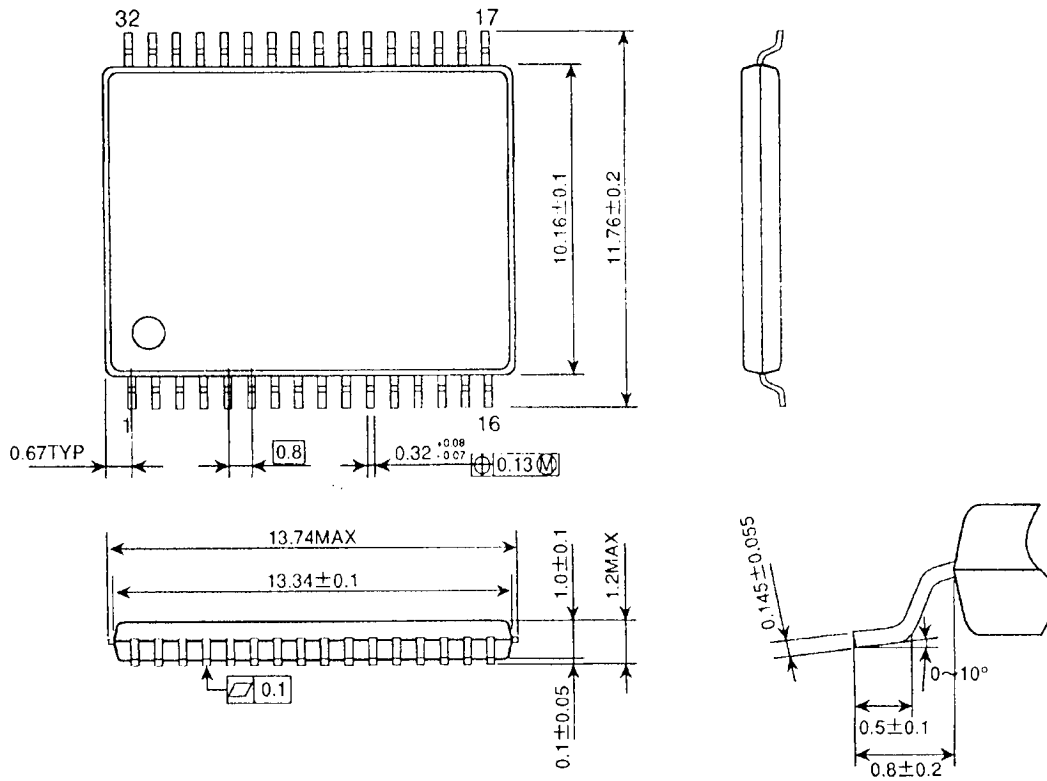

Weight: 0.34 g (typ)