

# 5W & 5X

## 5mm 11 Turn Surface Mount Cermet Trimming Potentiometer

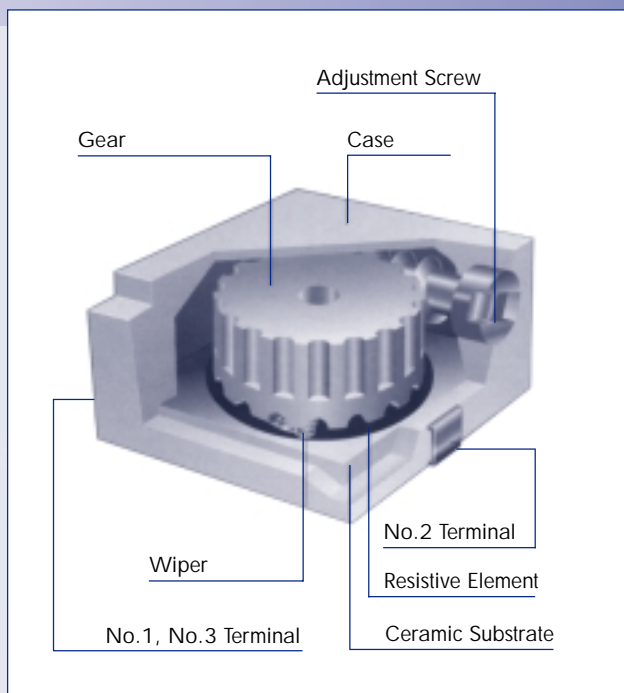

### FEATURES

- High resolution resulting from 11 turn design enables precise adjustment.
- 5mm miniature size for high density PCB mounting.
- Compatible with ultrasonic cleaning.
- Clutch mechanism prevents excessive wiper rotation.

### APPLICATIONS

- Measuring instruments, Sensors, CPU's, Industrial machines.

### SOLDERING

- Compatible with VPS reflow soldering method.

### PART NUMBERING

5X - XXX  
5W - XXX

### RATINGS

**Standard Resistance Range:**  
10 ohms to 2Mohms

**Nominal Resistance Tolerance:**  
±10%

**Power Rating:**  
70°C - 0.25W 125°C - 0W

**Max. Working Voltage:**  
300V

**Max. Wiper Current:**  
100mA max

**Operating Temperature Range:**  
-55°C to +125°C

**Effective Electrical Number of Turns:**  
11±2 turns

**Residual Resistance:**  
1% or 2Ω max, whichever is greater

**Contact Resistance Variation:**  
3% or 3Ω, whichever is greater

**Dielectric Strength:**  
600VAC

**Insulation Resistance:**  
100MΩ min (500VDC)

**Torque:**  
17.6mNm (180gf.cm)

### ENVIRONMENTAL CHARACTERISTICS

**Temperature Coefficient of Resistance:**  
R≤100Ω...±200ppm/°C  
R≥200Ω...±100ppm/°C

**Temperature Cycle:**  
ΔTR ±2%  
S.S. ±1%

**Humidity Exposure:**  
ΔTR ±2%  
1R 10MΩ min

**Vibration:**  
ΔTR ±1%  
S.S. ±1%

**Shock:**  
ΔTR ±1%  
S.S. ±1%

**Load Life:**  
ΔTR ±3% or 3Ω  
S.S. ±1%

**Low Temperature Exposure:**  
ΔTR ±1%  
S.S. ±1%

**High Temperature Exposure:**  
ΔTR ±2%  
S.S. ±1%

**Rotational Life (100 cycles):**  
No intermittence on resistance change

Δ TR: Total Resistance Change  
S.S.: Setting Stability  
IR: Insulation Resistance

# 5W & 5X

## 5mm 11 Turn Surface Mount Cermet Trimming Potentiometer

Nominal Resistance Values	Model Number	
	Top Adjustment (5W)	Side Adjustment (5X)
10	5W - 100	5X - 100
20	5W - 200	5X - 200
50	5W - 500	5X - 500
100	5W - 101	5X - 101
200	5W - 201	5X - 201
500	5W - 501	5X - 501
1K	5W - 102	5X - 102
2K	5W - 202	5X - 202
5K	5W - 502	5X - 502
10K	5W - 103	5X - 103
20K	5W - 203	5X - 203
50K	5W - 503	5X - 503
100K	5W - 104	5X - 104
200K	5W - 204	5X - 204
500K	5W - 504	5X - 504
1M	5W - 105	5X - 105
2M	5W - 205	5X - 205
Outline dimensions		
Schematic		
Clockwise		
Standard PCB layout		

In mm standard tolerance:  $\pm 0.3$

ISO 9001



**Spectrol Electronics Limited**

Garrard Way, Swindon, Wiltshire, SN3 3HY, England

Tel: +44 (0) 1793 521351 Fax: +44 (0) 1793 539255 Sales Fax: +44 (0) 1793 525163