

**PECL/LVPECL HF VCXO
SU-X36CXXX Series**

Description

The **SU-X36CXXX Series** of voltage controlled crystal oscillators (VCXO) provides high frequency with PECL/LVPECL complementary outputs. The outputs can be disabled for test automation or combining multiple clocks. The device does not use any frequency multiplication, providing exceptionally low Phase Noise and Jitter. It is packaged in a miniature, FR-4 based 9x14 mm SMD package.

Applications and Features

- Wide frequency range – 12.0MHz to 280.000MHz
- Fiber Channel; 10 GbE; Infiniband; Network Processors; SONET/SDH
- High Reliability - NEL HALT/HASS qualified for crystal oscillator start-up conditions
- Extremely Low Phase Noise, Low Jitter
- No Multiplication
- SONET ±20ppm overall free-run stability available
- Absolute Pull Range (APR) to ±100 ppm
- High shock resistance, to 1000g
- RoHS Compliant, Lead Free Construction

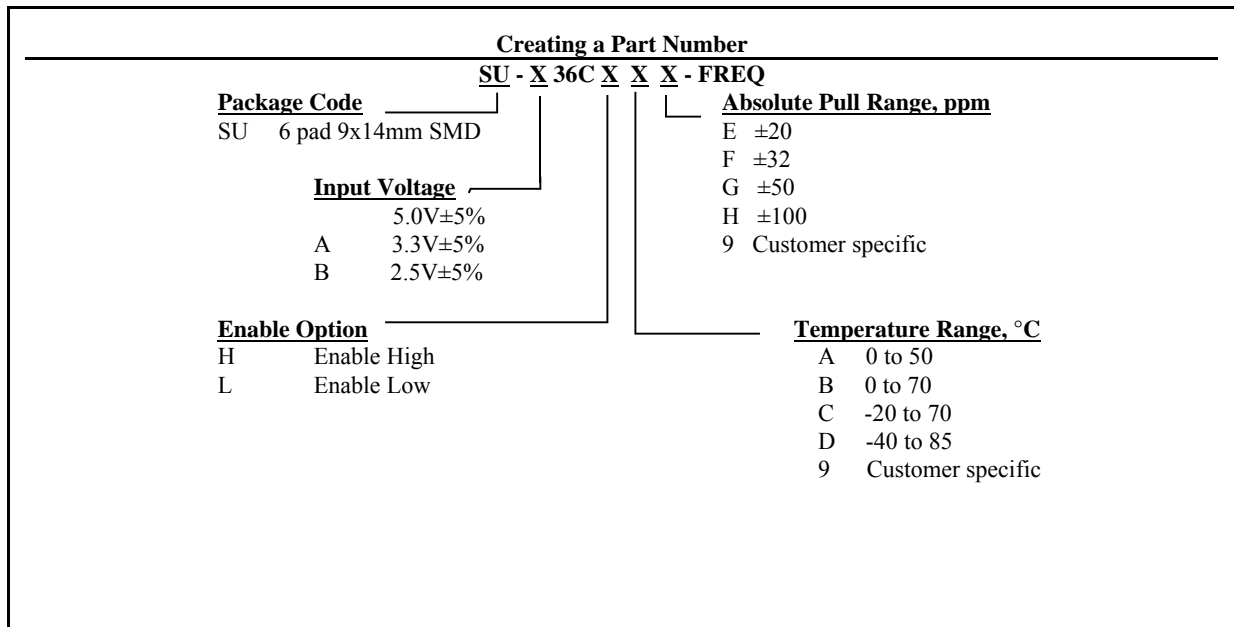

SU-X36CXXX Series Continued
PECL/LVPECL HF VCXO

Rev. B

Absolute Maximum Ratings

Parameter	Symbol	Value	Unit
Operating Temperature Range	To	-40 to +85	°C
Storage Temperature Range	Tst	-50 to +90	°C
Supply Voltage	Vcc	-0.5 to 4.5	V
Enable/Disable Voltage	Ven/dis	0 to Vcc	V

Electrical Parameters

Parameter	Symb	Conditions, Note	MIN	TYP	MAX	Unit	
Nominal Frequency	Fo		12		280	MHz	
Supply Voltage	Vcc	Code Code A Code B	4.75 3.135 2.375	5.0 3.3 2.5	5.25 3.465 2.625	V	
Supply current	Icc			60	80	mA	
Output Logic Type				LVPECL			
Load		Output to Vcc-2V, or Thevenin Equivalent		50		Ohm	
Output Levels	Voh Vol	overall	Vcc- 1.025		Vcc- 1.620	V	
Duty Cycle (Symmetry)		At 50% of output voltage swing	45/55	50/50	55/45	%	
Rise/Fall Time	Tr/Tf	20 to 80, 80 to 20 %		0.5	0.7	ns	
Jitter	Integrated	J	Integrated from Phase Noise, 12 KHz to 20 MHz, RMS		0.1	0.2	ps
			10 Hz to 80 KHz, RMS			1.0	ps
			50 KHz to 80 Mhz		0.3		ps
	Wavecrest characterized		Random period,		2.5		ps
			Accumul., pk-to-pk		17		ps
			Deterministic		0		ps
Sub-harmonics				None		dBc	
Phase Noise	f(Δf)	155.52 MHz	@ 10 Hz @100 Hz @1 KHz @10KHz @100KHz @>1MHz	-75 -105 -128 -142 -147 -147	-70 -100 -125 -140 -145 -145	dBc/Hz	
Frequency Stability, usually not specified - unless necessary, APR is specified to incorporate stability	ΔF/F	Overall, including initial calibration, temperature, aging 10 years, shock and vibration @ Vc=Vcc/2; APR 50ppm, or less	±20	±30		ppm	
Control Voltage Range	Vc		0V		Vcc	V	
Setability	Vcs	Vc to set F at Fo; T, Vcc, load - nominal, as shipped	0.4 Vcc	0.5 Vcc	0.6 Vcc	V	
Absolute Pull Range	APR	Over all conditions, see part # creation	20,32, 50,100			ppm	
Input Impedance	Zin	@ Fmod < 100 KHz	50			KOhm	
Modulation Bandwidth		At Vc = Vcc/2, -3dB	20			KHz	
Enable		Pin 2 = Low, 0 to Vcc- 1.62V	Enabled			V	
Disable		Pin 2 = High, Vcc-1.025V to Vcc	Disabled, Pin 4 = Logic "1", Pin 5 = Logic "0"			V	



SU-X36CXXX Series Continued PECL/LVPECL HF VCXO

Rev. B

Electrical Connection

Pin	Connection
1	V _{CO}
2	Enable/Disable
3	V _{EE}
4	Output
5	Output Complement
6	V _{CC}

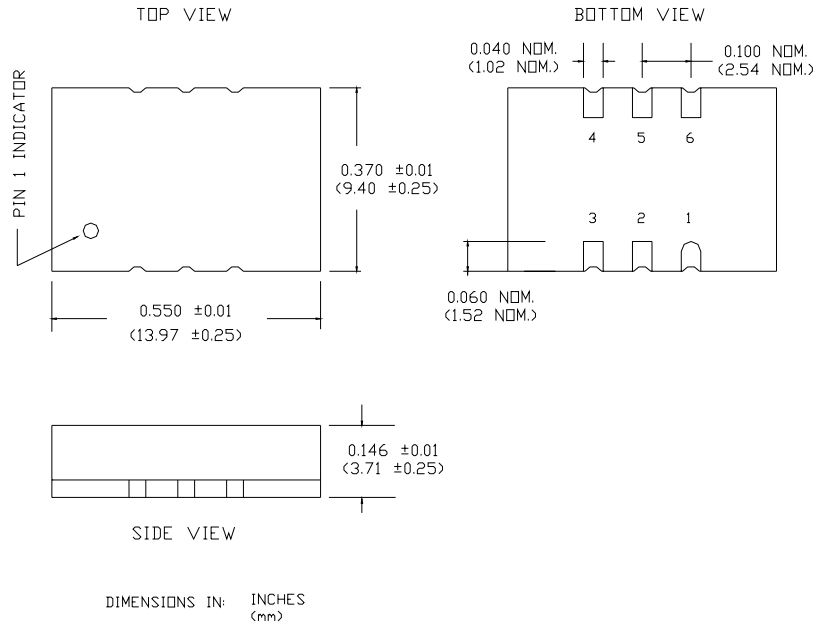

Environmental and

Mechanical Characteristics

Operating temp. range	see part # table
Mechanical Shock	Per MIL-STD-202, Method 213, Cond. E
Thermal Shock	Per MIL-STD-883, Method 1011, Cond. A
Vibration	Per MIL-STD-883, Method 2007, Cond. A
Hermetic Seal	Leak rate less than 1×10^{-8} atm.cc/s of helium
Soldering conditions	See MAX reflow profile below

Maximum Reflow Profile

