



## MULTIFUNCTION AUDIO PROCESSOR

### CASSETTE PREAMPLIFIER:

- FORWARD/REVERSE INPUTS GROUND COMPATIBLE
- INTERNAL SWITCHES FOR EQUALIZATION
- INTERNAL ADJUSTMENT FOR TRAKING
- INTERNAL ADJUSTMENT FOR OUTPUT

### AMS:

- INPUT GAIN CONTROL
- ADJUSTABLE GAIN VERSUS FREQUENCY

### AUDIOPROCESSOR:

- INPUTS: 1 FULLY DIFFERENTIAL, 1 DIFFERENTIAL, 1 STEREO AND 1 MONO
- INPUT GAIN FROM 0 TO 15dB (1dB STEP)
- VOLUME CONTROL FROM +16 TO -63dB (1dB STEP)
- BASS AND TREBLE CONTROL FROM -18 TO 18dB (1dB STEP)
- DIRECT MUTE, SOFT MUTE AND RADIO MUTE
- FOUR INDEPENDENT OUTPUT STAGES:
  - ATTENUATION CONTROL FROM 0 TO -79dB (1dB STEP)
  - BEEP CONTROL (ON/OFF, FRONT/REAR)

### STEREO DECODER:

- ROLL-OFF ADJUSTMENT
- SELECTABLE DEEMPHASIS
- 19KHz CANCELLATION
- HIGH CUT CONTROL
- STEREO BLEND

### NOISE BLANKER

- AUTOMATIC THRESHOLD CONTROL AND PROGRAMMABLE TRIGGER THRESHOLD
- INTEGRATED HIGH PASS FILTER
- PACKAGE: TQFP64 (14x14)

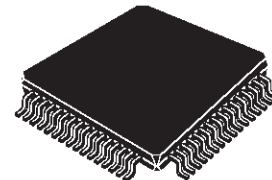

TQFP 64 (14x14)

ORDERING NUMBER: TDA7420

### DESCRIPTION

The TDA7420 I<sup>2</sup>C bus controlled multifunction audio processor contains all signal processing blocks of a high performance car radio, including audioprocessor, stereodecoder, noise blanker, different mute functions, cassette preamplifier and AMS function.

The use of BICMOS technology allows the implementation of several filter functions with switched capacitor techniques like fully integrated, adjustment free PLL Loop filter, pilot detector with integrator.

This minimizes the number of external components.

Due to a highly linear signal processing, using CMOS-switching techniques instead of standard bipolar multipliers, very low distortion and very low noise are obtained also in the stereodecoder part.

Very low DC stepping is obtained by use of the BICMOS technology.

# TDA7420

## ABSOLUTE MAXIMUM RATINGS

Symbol	Parameter	Value	Unit
V <sub>s</sub>	Operating Supply Voltage	10	V
T <sub>amb</sub>	Operating Temperature Range	-40 to 85	°C
T <sub>stg</sub>	Storage Temperature Range	-55 to 150	°C

## PIN CONNECTION

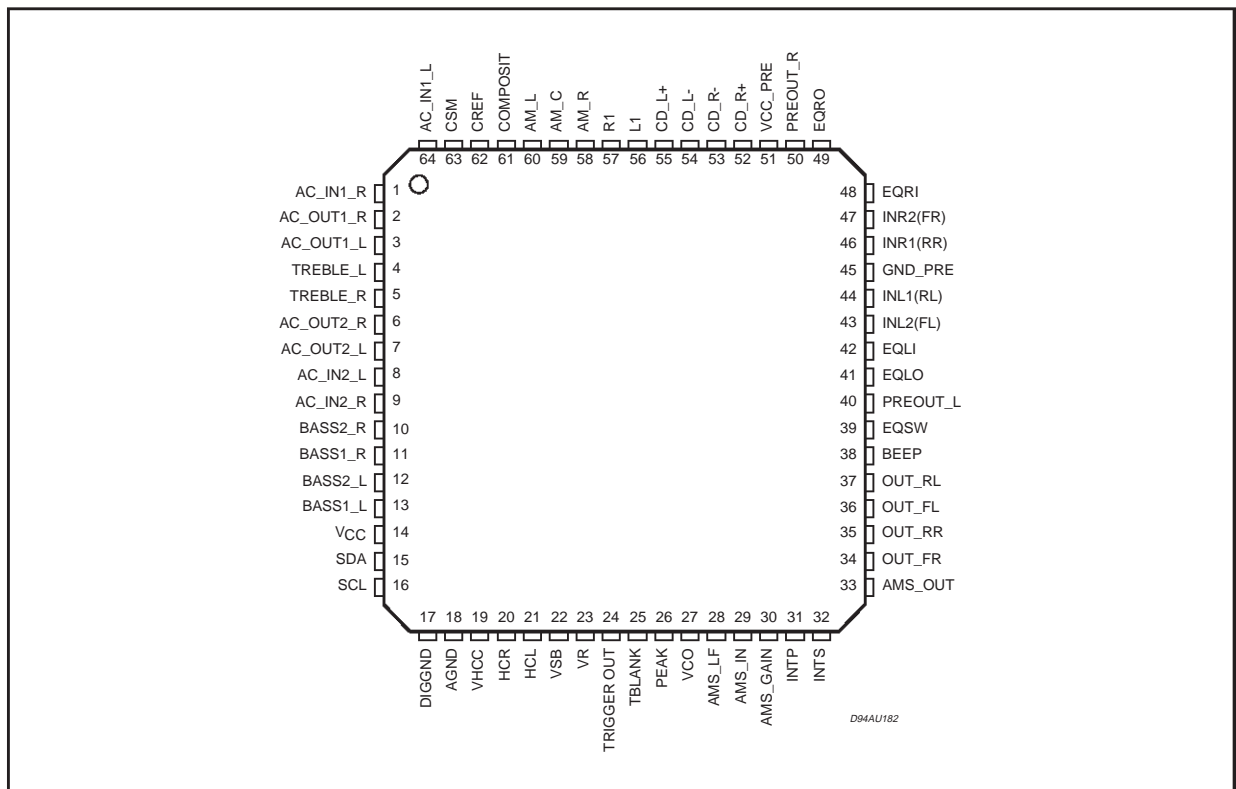

## THERMAL DATA

Symbol	Parameter	Value	Unit
R <sub>th j-pins</sub>	Thermal Resistance Junction-pins	max 85	°C/W

BLOCK DIAGRAM

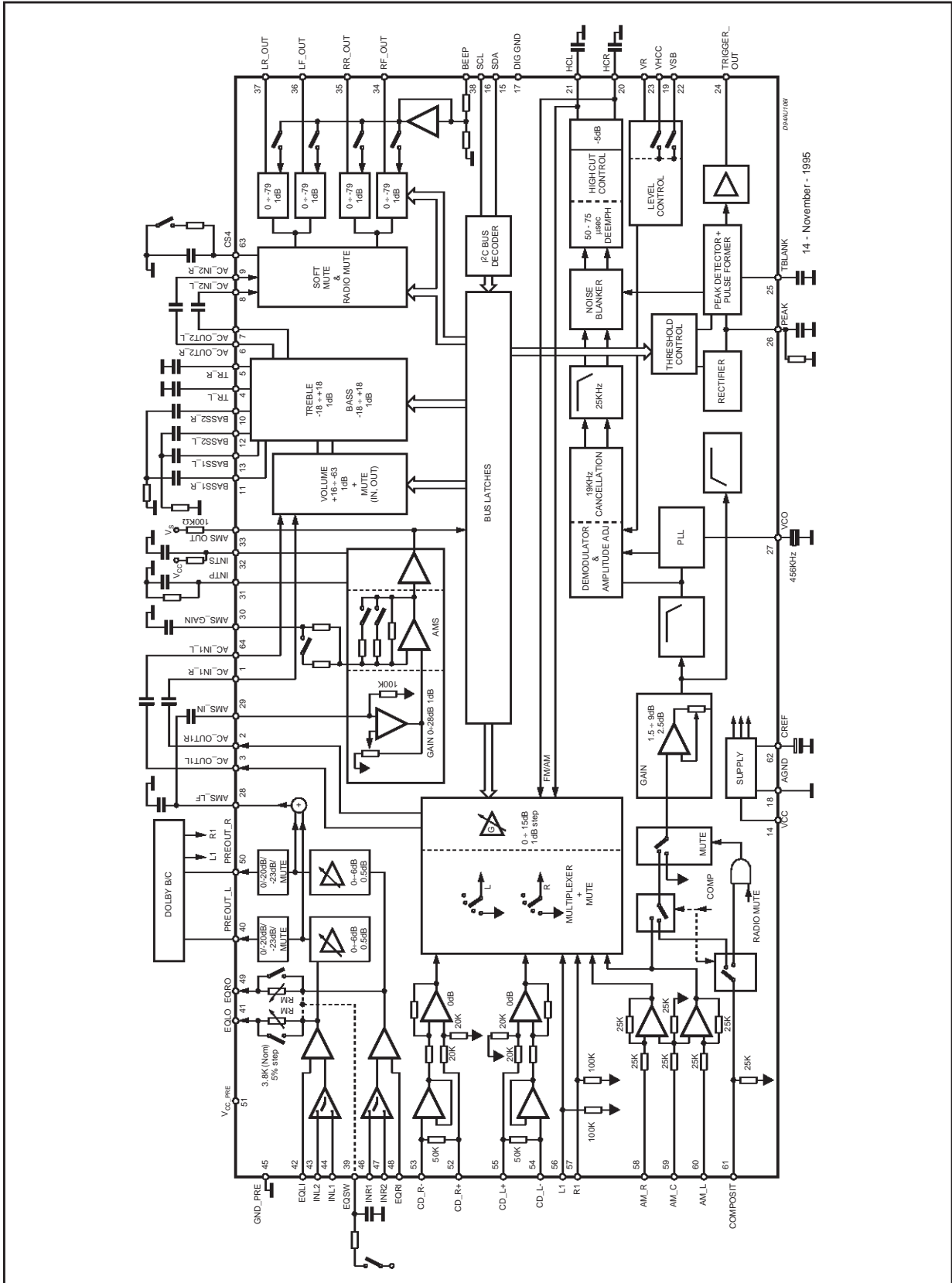

14 - November - 1995



## TDA7420

**ELECTRICAL CHARACTERISTICS** ( $V_s = 8.5V$ ;  $T_{amb} = 25^\circ C$ ;  $R_L = 10K\Omega$ ; all gains = 0dB;  $f = 1KHz$ ; unless otherwise specified, refer to the Test Circuit.)

Symbol	Parameter	Test Condition	Min.	Typ.	Max.	Unit
<b>INPUT SECTION</b>						
Differential Input Pins 52, 53, 54, 55						
$R_I$	Input Resistance		37	50	63	$K\Omega$
$V_{CL}$	Clipping Level	THD = 0.3%	2.0	2.5		V <sub>rms</sub>
CMRR	Common Mode Rejection Ratio		45	55		dB
$G_{DIFF}$	Differential Gain		-1	0	1	dB
Stereo Input Pins 56, 57						
$R_I$	Input Resistance		75	100	125	$K\Omega$
$V_{CL}$	Clipping Level		2.0	2.5		V <sub>rms</sub>
Quasi Differential Input Pins 58, 59, 60						
$R_I$	Input Resistance		18	25	32	$K\Omega$
$V_{CL}$	Clipping Level		2.0	2.5		V <sub>rms</sub>
Composite Input Pin 61						
$R_I$	Input Resistance		18	25	32	$K\Omega$
$V_{CL}$	Clipping Level		2.0	2.5		V <sub>rms</sub>
<b>MULTIPLEXER</b>						
$R_O$	Output Resistance (pin 2,3)		100	200	300	$\Omega$
$G_{MIN}$	Minimum Gain		-1	0	1	dB
$G_{MAX}$	Maximum Gain		14	15	16	dB
$G_{STEP}$	Step Resolution		0.5	1	1.5	dB
$V_{DC}$	Dc Steps	Adjacent Gain Step	-5	1	5	mV
		$G_{MIN}$ to $G_{MAX}$		2		mV
<b>VOLUME CONTROL</b>						
$R_I$	Input Resistance (1, 64)		24	33	42	$K\Omega$
$C_{MAX}$	Max Gain		15	16	17	dB
$A_{MAX}$	Max Attenuation			63		dB
$A_{STEP}$	Step Resolution Coarse Attenuation	$A_V = 16$ to $-40$ dB	0.5	1.0	1.5	dB
$E_A$	Attenuation Set Error	$G = 16$ to $-40$ dB	-1.5	0	1.5	dB
$E_T$	Tracking Error				2	dB
$V_{DC}$	DC Steps	Adjacent Attenuation Steps	-3	0.1	3	mV
		from 0dB to $A_{MAX}$		0.5	5	mV
<b>SOFT MUTE</b>						
$A_{MUTE}$	Mute Attenuation		40	50		dB
$t_D$	Delay Time	$C_{EXT} = 22nF$ ; 0 to $-20$ dB;		1.0		ms
		$I = I_{MAX}$ $I = I_{MIN}$		23		ms
<b>BASS CONTROL</b>						
$C_{RANGE}$	Control Range		$\pm 15$	$\pm 18$	$\pm 20$	dB
$A_{STEP}$	Step Resolution		0.5	1	1.5	dB
$R_B$	Internal Feedback Resistance		48	65	82	$K\Omega$

## ELECTRICAL CHARACTERISTICS (continued.)

Symbol	Parameter	Test Condition	Min.	Typ.	Max.	Unit
<b>TREBLE CONTROL</b>						
C <sub>RANGE</sub>	Control Range		±17	±18	±19	dB
A <sub>STEP</sub>	Step Resolution		0.5	1	1.5	dB
R <sub>T</sub>	Internal Feedback Resistance		37	50	63	KΩ
<b>SPEAKER ATTENUATORS</b>						
C <sub>RANGE</sub>	Control Range			79		dB
A <sub>STEP</sub>	Step Resolution	A <sub>V</sub> = 0 to -40dB	0.5	1	1.5	dB
A <sub>MUTE</sub>	Output Mute Attenuation		80	100		dB
E <sub>A</sub>	Attenuation Set Error	A <sub>V</sub> = 0 to -40dB			1.50	dB
V <sub>DC</sub>	DC Step	Adjacent Attenuation Steps		0.1	3	mV
<b>AUDIO OUTPUTS</b>						
V <sub>CLIP</sub>	Clipping Level	d = 0.3%	2.0	2.5		V <sub>RMS</sub>
R <sub>L</sub>	Output Load Resistance		2			KΩ
R <sub>OUT</sub>	Output Impedance		100	200	300	Ω
V <sub>DC</sub>	DC Voltage Level		3.35	3.6	3.85	V
<b>GENERAL</b>						
E <sub>NO</sub>	Output Noise	BW = 20Hz to 20KHz, flat Output Muted All gains = 0dB		4.0 5.0	15	μV μV
S/N	Signal to Noise Ratio	All gains 0dB; V <sub>O</sub> = 1V <sub>RMS</sub> ;		106		dB
d	Distortion	V <sub>I</sub> = 1V <sub>RMS</sub> ;		0.01	0.08	%
S <sub>C</sub>	Channel Separation Left/Right		80	95		dB
E <sub>T</sub>	Total Tracking Error	A <sub>V</sub> = 0 to -20dB; A <sub>V</sub> = -20 to -40dB;		0	1	dB
				0	2	dB
<b>BUS INPUT</b>						
V <sub>IL</sub>	Input Low Voltage				1	V
V <sub>IH</sub>	Input High Voltage		3			V
I <sub>IN</sub>	Input Current	V <sub>IN</sub> = 0.4V	-5		5	μA
V <sub>O</sub>	Output Voltage SDA Acknowledge	I <sub>O</sub> = 1.6mA		0.1	0.4	V
<b>SUPPLY</b>						
V <sub>IL</sub>	Supply Voltage		6.5	8.5	10.0	V
I <sub>S</sub>	Supply Current	Stereo Decoder = ON	25	33	41	mA
		Stereo Decoder = OFF	20	28	35	mA
SVR	Ripple Rejection C <sub>ref</sub> = 22μF	Audioprocessor		80		dB
		Stereo Decoder + Audioprocessor		60		dB

**PREAMPLIFIER** ( $V_s = 8.5V$ ;  $T_{amb} = 25^\circ C$ ;  $R_{IN} = 600\Omega$ ; unless otherwise specified (see test circuit))

Symbol	Parameter	Test Condition	Min.	Typ.	Max.	Unit
$R_I$	Input Resistance		100			$K\Omega$
$V_{out\ DC}$	Output Voltage DC (pin 40, 50)		3.2	3.5	3.9	V
$R_O$	Output Resistance (pins 40, 50)		100	200	300	$\Omega$
$I_i$	Input Bias Current				10	$\mu A$
$G_{VO}$	Open Loop Gain	$f = 400Hz$		110		dB
$G_V$	Closed Loop Gain	NAB short	31	32.5	34	dB
$R_N$	Resistance Normal Position		50	250	500	$\Omega$
$R_{MLR}$	Resistance Metal Position (left ,right)		2.85	3.8	4.75	$K\Omega$
$R_{MR}$	Step Resolution (versus $R_M$ )			5		%
$R_{Mmax}$	Maximum Value for $R_M$		3.42	4.56	5.7	$K\Omega$
$R_{Mmin}$	Minimum Value for $R_M$		2.28	3.04	3.8	$K\Omega$
	Dolby Level Control	Control Range	5.5	6.0	6.5	dB
		Step Resolution	0.25	0.5	0.75	dB
$S_R$	Slew Rate	NAB Short		1		$V/\mu s$
$e_N$	Total Input Noise	$R_{IN}=600\Omega$ ; unweighted		0.8		$\mu V$
		$R_{IN}=600\Omega$ ; CCIR warn		0.5		$\mu V$
		$R_{IN}=0$ ; unweighted		0.45		$\mu V$
	Output Attenuation Control	$D1, D0 = 00$	-0.75	0	0.75	dB
		$D1, D0 = 01$		-20		dB
		$D1, D0 = 10$		-23		dB
		$D1, D0 = 11$		-80		dB
THD	Total Harmonic Distortion	$V_O = 1V$ ; $f = 1KHz$ metal		0.02		%
		$V_O = 1V$ ; $f = 1KHz$ normal		0.02	0.1	%
		$V_O = 1V$ ; $f = 10KHz$ metal		0.05		%
		$V_O = 1V$ ; $f = 10KHz$ normal		0.04		%
		$V_O = 2V$ ; $f = 1KHz$				%
$SVR_1$	Ripple Rejection			75		dB
$C_s$	Channel Separation (L to R)		45	60		dB
$C_{CT}$	Channel Cross talk (F to R)		60	80		dB
S/N	Signal to Noise	$V_O = 388mV$ ; metal; CCIR arm		65		dB

**AUDIO MUSIC SENSOR**

$I_{AMSOUT}$	AMS Output Current				5	mA
$V_{AMSOUT}$	AMS Output Low Level	$I_{AMOUT} = 2mA$		500	800	mV
$R_{i-29}$	Input Resistance AMS Gain (pin 23)		75	100	125	$K\Omega$
$V_{TH1}$	Interprogram Threshold Voltage		1.2	1.45	1.7	V
$V_{TH2}$	Interspace Threshold Voltage		4.8	5.2	5.6	V
$AMS_{th}$	AMS Threshold Level		2.0	2.8	3.6	V
$V_{INTP}$	INTP Output Voltage	$I_{OUT} = 2mA$		0.2	0.8	mV
$V_{INTS}$	INTS Output Voltage	$I_{OUT} = 2mA$		0.2	0.8	mV
	INTP Charge Current		50	70	150	$\mu A$
	INTS Charge Current		50	70	150	$\mu A$
$S_G$	Gain Sensitivity	min Gain $V_{30}$ vs $V_{29}$		11		dB
		max Gain $V_{30}$ vs $V_{29}$		42		dB
$R_{i-30}$	AMS Gain Resistance	$D6, D5 = 00$	13	17.5	22	$K\Omega$
		$D6, D5 = 01$	16.5	22	27.5	$K\Omega$
		$D6, D5 = 11$	75	100	125	$K\Omega$

**STEREO DECODER PART**

**ELECTRICAL CHARACTERISTICS** ( $V_S = 8.5V$ ; de-emphasis time:  $T = 50\mu s$ ; nominal MPX input voltage on pin 61 (composite):  $V_{MPX} = 0.5V_{RMS}$  (75KHz deviation); modulation frequency = 1KHz;  $G_I = 1.5dB$ ;  $T_{amb} = 27^\circ C$ ; unless otherwise specified)

Symbol	Parameter	Test Condition	Min.	Typ.	Max.	Unit
SVRR	Supply Voltage Ripple Rejection	$V_{RIPPLE} = 100mV$ ; $f = 1KHz$	50	65		dB
$V_O$	DC Output Voltage (HCL, HCR)		3.95	4.25	4.55	V
$\alpha$	Channel Separation	$V_{SB} - V_R = 100mV_{DC}$		50		dB
THD	Total Harmonic Distortion			0.02	0.3	%
$\frac{S+N}{N}$	Signal Plus Noise to Noise Ratio	$f = 20Hz$ to $16KHz$ ; $S = 2V_{RMS}$		91		dB
<b>MONO/STEREO SWITCH</b>						
$V_{INTH}$	Pilot Threshold Voltage	for stereo "ON" $P_{th} = 1$ $P_{th} = 0$	12 19	16 26	22 34	$mV_{RMS}$ $mV_{RMS}$
$V_{INTH}$	Pilot Threshold Voltage	for stereo "OFF" $P_{th} = 1$ $P_{th} = 0$	8 16	14 22	20 28	$mV_{RMS}$ $mV_{RMS}$
<b>STEREO BLEND</b>						
$V_{SB-VR}$	Control Voltage for Channel Separation	$\alpha = 6dB$ ; (note 5)	-300	-250	-200	mV
		$\alpha = 26dB$ ;		-80		mV
<b>HIGH CUT CONTROL</b>						
$\tau_{deemp}$	De-Emphasis Time Constant	$C_L, C_R = 1nF$ ; STDDS = 0 $V_{HCC} - V_R = 100mV$	43	50	57	$\mu s$
		$C_L, C_R = 1nF$ ; STDDS = 1 $V_{HCC} - V_R = 100mV$	64	75	86	$\mu s$
$R_{HCC}$	High Cut Control Resistance	$V_{HCC} - V_R = 100mV$ ; STDDS = 0	43	50	57	$K\Omega$
		$V_{HCC} - V_R = -0.5V$ (note 5)	115	150	185	$K\Omega$
<b>VCO</b>						
$f_{OSC}$	Oscillator Frequency			456		KHz
$\Delta f/f$	Capture and Hold Range		0.5	1		%
<b>CARRIER AND HARMONIC SUPPRESSION AT THE OUTPUT</b>						
$\alpha_{19}$	Pilot Signal $f = 19KHz$		40	55		dB
$\alpha_{38}$	Subcarrier $f = 38KHz$			75		dB
$\alpha_{57}$	Subcarrier $f = 57KHz$			62		dB
$\alpha_{76}$	Subcarrier $f = 76KHz$			90		dB
<b>INTERMODULATION (note 1)</b>						
$\alpha_2$	$f_{mod} = 10KHz$ ; $f_{spur} = 1KHz$			65		dB
$\alpha_3$	$f_{mod} = 13KHz$ ; $f_{spur} = 1KHz$			75		dB
<b>TRAFFIC RADIO (note 2)</b>						
$\alpha_{57}$	Signal $f = 57KHz$			70		dB
<b>SCA - SUBSIDIARY COMMUNICATIONS AUTHORIZATION (note 3)</b>						
$\alpha_{67}$	Signal $f = 67KHz$			75		dB
<b>ACI - ADJACENT CHANNEL INTERFERENCE (note 4)</b>						
$\alpha_{114}$	Signal $f = 114KHz$			95		dB
$\alpha_{190}$	Signal $f = 190KHz$			84		dB

**NOTES TO THE CHARACTERISTICS**

**1 INTERMODULATION SUPPRESSION**

$$\alpha_2 = \frac{V_{O(\text{signal})}(\text{at1KHz})}{V_{O(\text{spurious})}(\text{at1KHz})}; f_s = (2 \times 10\text{KHz}) - 19\text{KHz}$$

$$\alpha_3 = \frac{V_{O(\text{signal})}(\text{at1KHz})}{V_{O(\text{spurious})}(\text{at1KHz})}; f_s = (3 \times 13\text{KHz}) - 38\text{KHz}$$

measured with : 91% mono signal; 9% pilot signal; fm=10KHz or 13KHz.

**2. TRAFFIC RADIO (V.F.) suppression**

$$\alpha_{57}(\text{V.W.F.}) = \frac{V_{O(\text{signal})}(\text{at1KHz})}{V_{O(\text{spurious})}(\text{at1KHz} \pm 23\text{Hz})}$$

measured with : 91% stereo signal; 9% pilot signal; fm=1KHz; 5% subcarrier (f=57KHz, fm = 23Hz AM, m = 60%)

**3. SCA (SUBSIDIARY COMMUNICATIONS AUTHORIZATION)**

$$\alpha_{67} = \frac{V_{O(\text{signal})}(\text{at1KHz})}{V_{O(\text{spurious})}(\text{at9KHz})}; f_s = (2 \times 38\text{KHz}) - 67\text{KHz}$$

measured with : 81% mono signal; 9% pilot signal; fm=1KHz; 10% SCA - subcarrier (fs = 67KHz, unmodulated).

**4. ACI (ADJACENT CHANNEL INTERFERENCE)**

$$\alpha_{114} = \frac{V_{O(\text{signal})}(\text{at1KHz})}{V_{O(\text{spurious})}(\text{at4KHz})}; f_s = 110\text{KHz} - (3 \times 38\text{KHz})$$

$$\alpha_{190} = \frac{V_{O(\text{signal})}(\text{at1KHz})}{V_{O(\text{spurious})}(\text{at4KHz})}; f_s = 186\text{KHz} - (5 \times 38\text{KHz}) -$$

measured with 90% mono signal; 9% pilot signal; fm = 1KHz; 1% spurious signal (fs = 110KHz or 186KHz, unmodulated).

5: Control range for High Cut Control and Stereo Blend is  $V_R - 400\text{mV} \leq V_{SB}, V_{HCC} \leq V_R$

**Figure : High Cut Control**

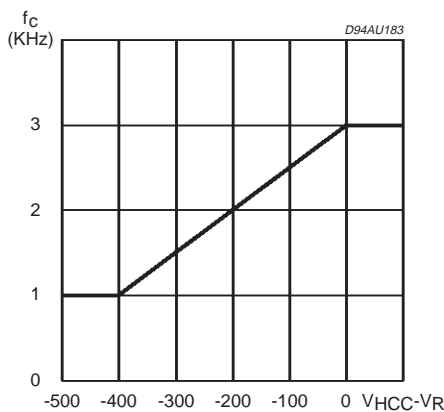

**Figure : Stereo Blend**

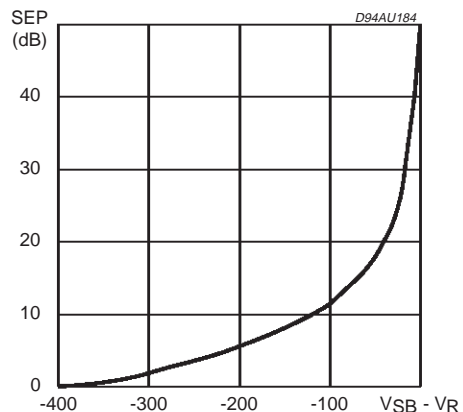



**NOISE BLANKER PART****FEATURES:**

- INTERNAL 2nd ORDER 140KHz HIGH-PASS FILTER
- NOISE RECTIFIER OUTPUT FOR SIGNAL QUALITY DETECTION
- PROGRAMMABLE TRIGGER THRESHOLD
- TRIGGER THRESHOLD DEPENDENT ON HIGH FREQUENCY NOISE WITH PROGRAMMABLE GAIN

- ADDITIONAL CIRCUITS FOR DEVIATION AND FIELD STRENGTH -DEPENDENT TRIGGER ADJUSTMENT
- BLANKING TIME PROGRAMMABLE BY EXTERNAL CAPACITOR
- VERY LOW OFFSET CURRENT DURING HOLD TIME DUE TO OPAMPS WITH MOS INPUTS

**ELECTRICAL CHARACTERISTICS (continued)**

Symbol	Parameter	Test Condition		Min.	Typ.	Max.	Unit
$V_{TRMIN}$	Trigger Threshold (*) <sup>1)</sup> minimum	Measured with NBT = 000 $V_{PEAK} = 1.2V$	D2 on byte 2 = 1 D2 on byte 2 = 0	100	150 30	200	mVp
$V_{TRMIN}$	Trigger Threshold <sup>1)</sup> maximum	Measured with NBT = 111 $V_{PEAK} = 1.2V$	D2 on byte 2 = 1 D2 on byte 2 = 0	130	185 65	250	mVp
$V_{TRSTEP}$	Trigger Threshold Step Size				5		mVp
$V_{TRNOISE}$	Noise Adjusted Trigger Threshold <sup>2)</sup>	Measured with $V_{PEAK} = 1.4V$ D2 on byte 2 = 0	NAT = 00 NAT = 01 NAT = 10 NAT = 11		140 180 240 280		mVp mVp mVp mVp
$V_{PEAK}$	Rectifier Voltage D2 on byte 2 = 1	$V_{MPX} = 0mV$			0.9		V
		$V_{MPX} = 50mV$ $f = 200KHz$			1.5		V
		$V_{MPX} = 100mV$ $f = 200KHz$			2.0		V
$V_{RECTDEV}$	Deviation Dependent Rectifier Voltage <sup>3)</sup>	Measured with $V_{MPX} = 500mV$ (75KHz dev.)	OVD = 00(off) OVD = 01 OVD = 10 OVD = 11		0.9 1.2 2.0 2.8		V V V V
$V_{RECTFS}$	Field Strength Controlled Rectifier Voltage <sup>4)</sup>	Measured with $V_{MPX} = 0mV$ $V_{SB}-V_R = -500mV$ (fully mono.)	FSC = 00(off) FSC = 01 FSC = 10 FSC = 11		0.9 1.3 1.9 2.4		V V V V
$T_S$	Suppression Pulse Duration	CBLANK = 330pF			40		$\mu s$
$I_{OS}$	Input Offset Current During Suppression Time				10		pA

(\*) All thresholds are measured by using a pulse with  $T_R = 2\mu s$ ,  $T_{HIGH} = 2\mu s$  and  $T_F = 10\mu s$ .  
The repetition rate must not increase the PEAK voltage.

1) NTB represents bits D0 - D2 of NB byte 1

2) NAT represents bits D3 - D4 of NB byte 1

3) OVD represents bits D5 - D6 of NB byte 1

4) FSC represents bits D0 - D1 of NB byte 2

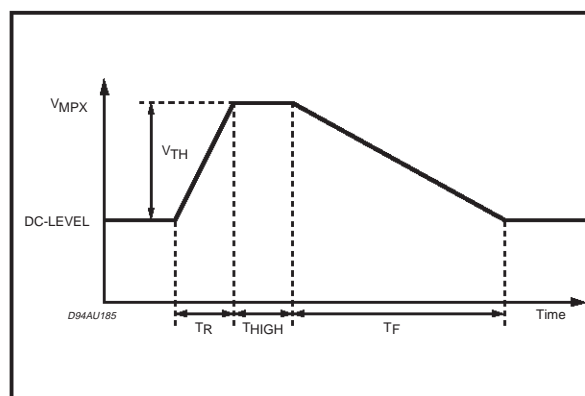

## DESCRIPTION

### DESCRIPTION OF THE NOISEBLANKER

In the normal automotive environment the MPX signal is disturbed by ignition spikes, motors and high frequency switches etc.

The aim of the noiseblanker part is to cancel the influence of the spikes produced by these components.

Therefore the output of the stereodecoder is switched off for a time of 40µs (average spike duration).

In a first stage the spikes must be detected but to avoid a wrong triggering on high frequency noise a complex trigger control is implemented.

Behind the triggerstage a pulse former generates the 40µs "blanking" pulse.

In the following section all of these circuits are described in their function and their programming, too (see fig.1).

#### 1.1 Normal Trigger Path (RECT-PEAK, ACT, PEAK-COMP, BLANK-COMP, BIAS-MONO)

The Incoming MPX signal is highpass-filtered, amplified and rectified (block RECT-PEAK).

The second order highpass-filter has a corner-frequency of 140KHz.

The gain of the rectifier can be controlled by the bit D2 of the noiseblanker byte2.

If programming bit D2 to zero the gain is only half of the nominal value.

All trigger thresholds must be roughly doubled in this case. The rectified signal, RECT, is used to generate by peak-rectification a signal called PEAK, which is available at the PEAK pin.

Also noise with a frequency >100KHz increases the PEAK voltage. The value of the PEAK voltage influences the trigger threshold voltage  $V_{th}$  (block ATC).

Both signals, RECT and PEAK+ $V_{th}$  are fed to a comparator (block PEAK-COMP) which outputs a sawtooth-sharped waveform at the TBLANK pin, it is triggered.

A second comparator (block BLANK-COMP) forms the internal blanking duration of 40µs.

The noiseblanker is supplied by his own biasing circuit (block BIAS-MONO).

#### 1.2 Automatic Threshold Control (ATC)

There are two independent possibilities for programming the trigger threshold:

- a) the minimum threshold in 8 steps (bits D0-D2,

NB-byte 1)

- b) the maximum threshold in 4 steps (bits D3-D4, NB-byte 1) (see fig.2)

The low threshold is used in combination with a good MPX signal without any noise.

The sensitivity in this operation is high, depending only on the programmed "Low Trigger Threshold", bits D0-D2 of the noiseblanker byte 1.

It is independent of the PEAK voltage.

The MPX signal is noisy (low fieldstrength) the PEAK signal increases due to the higher noise, which is also rectified (see part 1.1).

With increasing of the PEAK voltage the trigger threshold voltage increases, too. This particular gain is programmable in 4 steps (see fig.2).

#### 1.3 Automatic Threshold Control by the Stereoblend voltage (ATC-SB)

Besides the noise controlled threshold adjustment there is an additional possibility for influencing the trigger.

It is controlled by the difference between  $V_{sb}$  and  $V_r$ , similar to the Stereoblend.

The reason for implementing such a second control will be explained in the following:

The point where the MPX signal starts to become noisy is fixed by the RF part.

Therefore also the starting point of the normal noise controlled trigger adjustment is fixed (fig.3).

But in some cases the behaviour of the noiseblanker can be improved by increasing the threshold even in a region of higher fieldstrength, for the MPX signal often shows distortion in this range.

Because of the overlap of this range and the range of the stereo/mono transition it can be controlled by  $V_{sb}$  and  $V_r$ .

This threshold increase is programmable in 3 steps or switched off (see fig.3).

#### 1.4 Over Deviation Detector (MPX-RECT)

Sometimes when listening to stations with a higher deviation than 75KHz the noiseblanker triggers on the high frequency modulation.

To avoid this blanking, which causes noise in the output signal, the noiseblanker offers a deviation-dependent threshold adjustment.

By rectifying the MPX signal a further signal representing the actual deviation is obtained.

It is used to increase the PEAK voltage.

Offset and gain of this circuit are programmable in 3 steps (the first step turns off the detector, see fig.4).

Figure 1: Block Diagram of the Noise Blanker

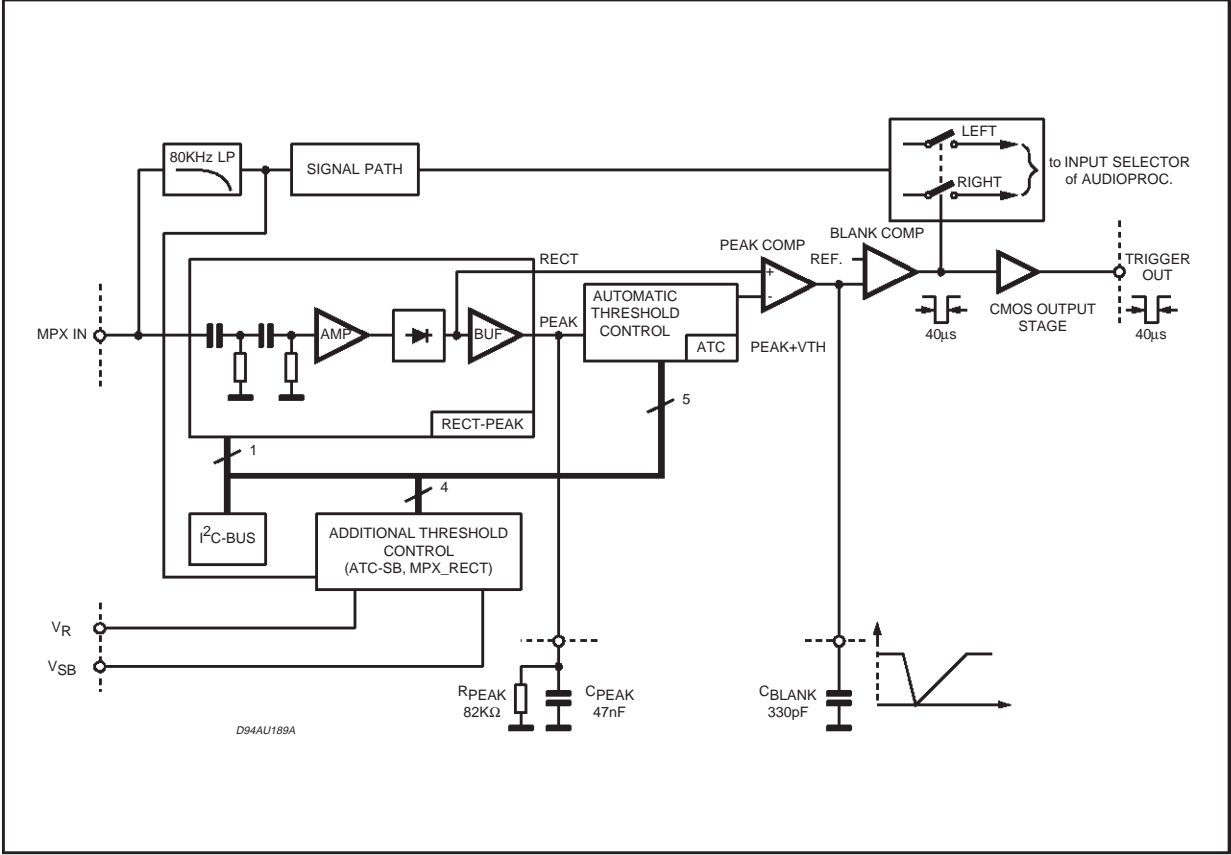

Figure 2: Trigger Threshold vs.  $V_{peak}$

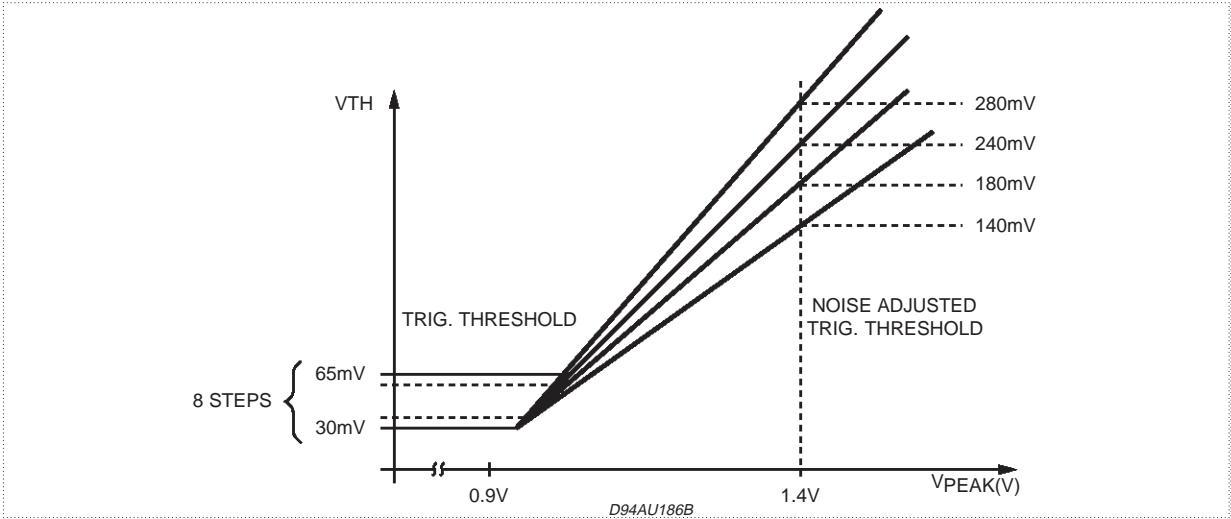

Figure 3: Behaviour of the Field Strength Controlled Threshold Adjustment

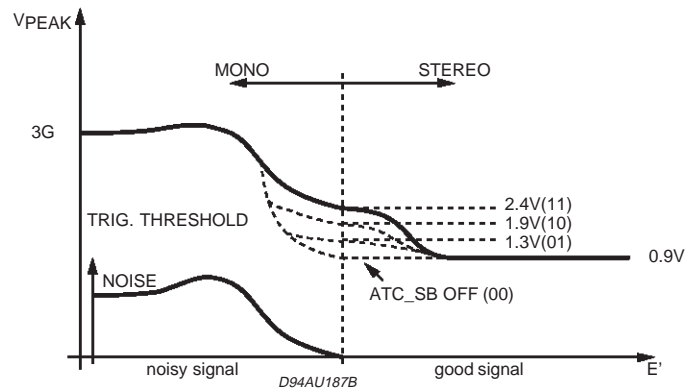
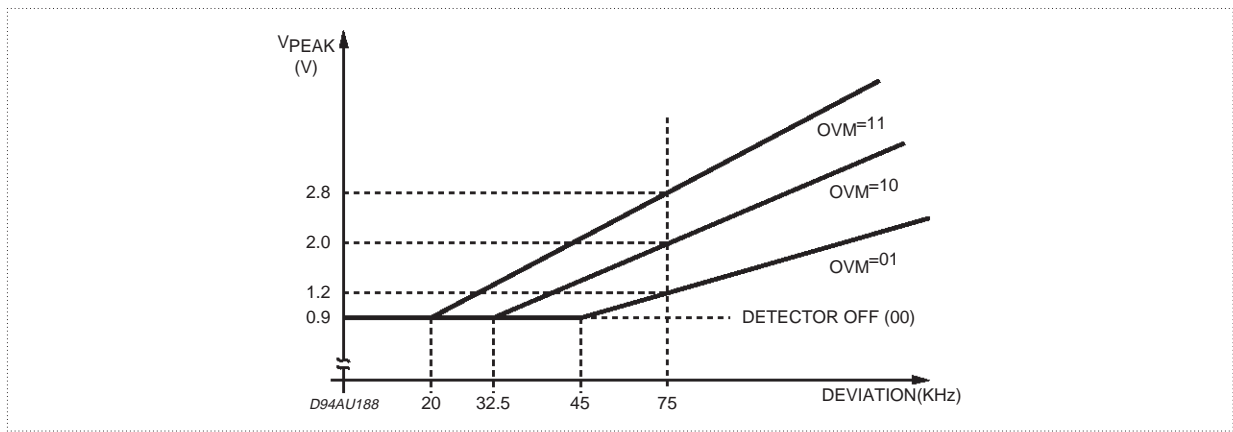

Figure 4: Behaviour of the Deviation Dependent Threshold Adjust (Over Deviation Detector)



**I<sup>2</sup>C BUS INTERFACE**  
**Interface Protocol**

The interface protocol comprises:

- A start condition (s)
- A chip address byte, (the LSB bit determines read/write transmission).
- A subaddress byte
- A sequence of data (N-bytes + acknowledge)
- A stop condition (P)

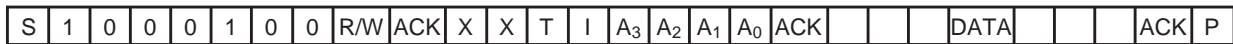
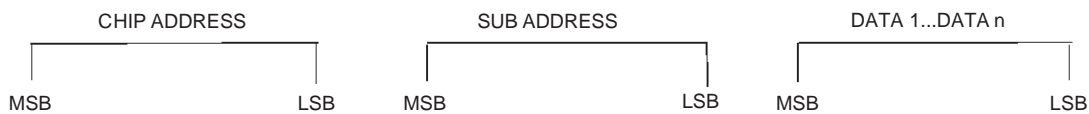

ACK = Acknowledge

S = Start

P = Stop

I = Autoincrement

MAX CLOCK SPEED 500kbits/s

**Autoincrement**

If bit I in the subaddress byte is set to "1", the autoincrement of subaddress is enabled.

**TRANSMITTED DATA (SEND MODE)**

MSB							LSB	
X	X	X	X	X	ST	SM	AMS	HIGH = Active

AMS = True Blank Detected

SM = Soft mute activated

ST = Stereo (HIGH = active)

**SUBADDRESS (RECEIVE MODE)**

MSB				LSB				FUNCTION
X	X	X	I	D <sub>3</sub>	D <sub>2</sub>	D <sub>1</sub>	D <sub>0</sub>	
				0	0	0	0	Mux
				0	0	0	1	Volume
				0	0	1	0	Treble
				0	0	1	1	Bass
				0	1	0	0	Speaker Attenuator LF
				0	1	0	1	Speaker Attenuator RF
				0	1	1	0	Speaker Attenuator LR
				0	1	1	1	Speaker Attenuator RR
				1	0	0	0	Mute & Beep
				1	0	0	1	Stereodecoder
				1	0	1	0	Noise Blanker 1
				1	0	1	1	Noise Blanker 2
				1	1	0	0	AMS
				1	1	0	1	Dolby Level Control
				1	1	1	0	Metal Resistance Control
				1	1	1	1	Preamplifier Attenuation

If bit in the subaddress byte is set to "1", the autoincrement of subaddress is enabled

## INPUT SELECTOR

MSB				LSB				FUNCTION
D7	D6	D5	D4	D3	D2	D1	D0	
				0	0	0	0	Input Gain
				0	0	0	1	0dB
				0	0	1	0	1dB
				0	0	1	1	2dB
				0	1	0	0	3dB
				0	1	0	1	4dB
				0	1	1	0	5dB
				0	1	1	1	6dB
				1	0	0	0	7dB
				1	0	0	1	8dB
				1	0	1	0	9dB
				1	0	1	1	10dB
				1	1	0	0	11dB
				1	1	0	1	12dB
				1	1	1	0	13dB
				1	1	1	1	14dB
				1	1	1	1	15dB
	0	0	0					Full diff CD
	0	0	1					Stereo
	0	1	0					Stereo Decoder
	0	1	1					AM quasi diff input
	1	0	0					Quasi diff CD
	1	0	1					Not allowed
	1	1	0					Not allowed
	1	1	1					AM Mono (AM R input)

## VOLUME

MSB				LSB				FUNCTION
D7	D6	D5	D4	D3	D2	D1	D0	
								<b>-1 dB STEPS</b>
					0	0	0	-0dB
					0	0	1	-1dB
					0	1	0	-2dB
					0	1	1	-3dB
					1	0	0	-4dB
					1	0	1	-5dB
					1	1	0	-6dB
					1	1	1	-7dB
								<b>-8 dB STEPS</b>
	0	0	0	0				16dB
	0	0	0	1				8dB
		0	1	0				0dB
		0	1	1				-8dB
		1	0	0				-16dB
		1	0	1				-24dB
		1	1	0				-32dB
		1	1	1				-40dB
	1	0	0	0				-48dB
	1	0	0	1				-56dB
1								Mute

# TDA7420

## TREBLE

MSB				LSB				FUNCTION
D7	D6	D5	D4	D3	D2	D1	D0	
		1	1	0	0	1	0	-18dB
		1	1	0	0	0	1	-17dB
		1	1	0	0	0	0	-16dB
		1	0	1	1	1	1	-15dB
		1	0	1	1	1	0	-14dB
		1	0	1	1	0	1	-13dB
		1	0	1	1	0	0	-12dB
		1	0	1	0	1	1	-11dB
		1	0	1	0	1	0	-10dB
		1	0	1	0	0	1	-9dB
		1	0	1	0	0	0	-8dB
		1	0	0	1	1	1	-7dB
		1	0	0	1	1	0	-6dB
		1	0	0	1	0	1	-5dB
		1	0	0	1	0	0	-4dB
		1	0	0	0	1	1	-3dB
		1	0	0	0	1	0	-2dB
		1	0	0	0	0	1	-1dB
		1	0	0	0	0	0	0dB
		0	0	0	0	0	0	0dB
		0	0	0	0	0	1	1dB
		0	0	0	0	1	0	2dB
		0	0	0	0	1	1	3dB
		0	0	0	1	0	0	4dB
		0	0	0	1	0	1	5dB
		0	0	0	1	1	0	6dB
		0	0	0	1	1	1	7dB
		0	0	1	0	0	0	8dB
		0	0	1	0	0	1	9dB
		0	0	1	0	1	0	10dB
		0	0	1	0	1	1	11dB
		0	0	1	1	0	0	12dB
		0	0	1	1	0	1	13dB
		0	0	1	1	1	0	14dB
		0	0	1	1	1	1	15dB
		0	1	0	0	0	0	16dB
		0	1	0	0	0	1	17dB
		0	1	0	0	1	0	18dB



**BASS**

MSB				LSB				FUNCTION
D7	D6	D5	D4	D3	D2	D1	D0	
		1	1	0	0	1	0	-18dB
		1	1	0	0	0	1	-17dB
		1	1	0	0	0	0	-16dB
		1	0	1	1	1	1	-15dB
		1	0	1	1	1	0	-14dB
		1	0	1	1	0	1	-13dB
		1	0	1	1	0	0	-12dB
		1	0	1	0	1	1	-11dB
		1	0	1	0	1	0	-10dB
		1	0	1	0	0	1	-9dB
		1	0	1	0	0	0	-8dB
		1	0	0	1	1	1	-7dB
		1	0	0	1	1	0	-6dB
		1	0	0	1	0	1	-5dB
		1	0	0	1	0	0	-4dB
		1	0	0	0	1	1	-3dB
		1	0	0	0	1	0	-2dB
		1	0	0	0	0	1	-1dB
		1	0	0	0	0	0	0dB
		0	0	0	0	0	0	0dB
		0	0	0	0	0	1	1dB
		0	0	0	0	1	0	2dB
		0	0	0	0	1	1	3dB
		0	0	0	1	0	0	4dB
		0	0	0	1	0	1	5dB
		0	0	0	1	1	0	6dB
		0	0	0	1	1	1	7dB
		0	0	1	0	0	0	8dB
		0	0	1	0	0	1	9dB
		0	0	1	0	1	0	10dB
		0	0	1	0	1	1	11dB
		0	0	1	1	0	0	12dB
		0	0	1	1	0	1	13dB
		0	0	1	1	1	0	14dB
		0	0	1	1	1	1	15dB
		0	1	0	0	0	0	16dB
		0	1	0	0	0	1	17dB
		0	1	0	0	1	0	18dB
	1							Non DC extended bass
	0							DC extended bass

## SPEAKERS ATTENUATORS

MSB							LSB		LF, LR, RF, RR
D7	D6	D5	D4	D3	D2	D1	D0		
								<b>-1dB STEPS</b>	
					0	0	0	0dB	
					0	0	1	-1dB	
					0	1	0	-2dB	
					0	1	1	-3dB	
					1	0	0	-4dB	
					1	0	1	-5dB	
					1	1	0	-6dB	
					1	1	1	-7dB	
								<b>8dB STEPS</b>	
	0	0	0	0				0dB	
	0	0	0	1				-8dB	
	0	0	1	0				-16dB	
	0	0	1	1				-24dB	
	0	1	0	0				-32dB	
	0	1	0	1				-40dB	
	0	1	1	0				-48dB	
	0	1	1	1				-56dB	
	1	0	0	0				-64dB	
	1	0	0	1				-72dB	
	1	1	0					Mute	
	1	0	1						
	1	1	1						

## MUTE &amp; BEEP

MSB							LSB		FUNCTION
D7	D6	D5	D4	D3	D2	D1	D0		
							1	Soft Mute - FAST SLOPE	
							0	Soft Mute - Slow Slope	
						1		Soft Mute OFF	
						0		Soft Mute ON	
					0	0		Direct Input Mute ON	
					1	0		Direct Input Mute OFF	
				0		0		Radio Mute ON	
				1		0		Radio Mute OFF	
			1					Composit Input Enabled	
			0					Composit Mute Enabled	
		1						Beep ON - Front	
	1							Beep ON - Rear	
1								VCO OFF	
0								VCO ON	

## STEREO DECODER

MSB							LSB		FUNCTION
D7	D6	D5	D4	D3	D2	D1	D0		
<b>Input Gain</b>									
						0	0	1.5dB Input Gain	
						0	1	4.0dB Input Gain	
						1	0	6.5dB Input Gain	
						1	1	9dB Input Gain	
<b>Roll Off Adjustement</b>									
			0	0	1			20.2%	
			0	1	0			21.9%	
			0	1	1			23.7%	
			1	0	0			25.5%	
			1	0	1			27.3%	
			1	1	0			29.2%	
			1	1	1			31%	
		0						Deemph. Time Constant 75 $\mu$ s	
		1						Deemph. Time Constant 50 $\mu$ s	
	1							Forced Mono	
	0							Stereo Enabled	
0								Pilot Threshold High	
1								Pilot Threshold Low	

## NOISE BLANKER 1

MSB							LSB		FUNCTION
D7	D6	D5	D4	D3	D2	D1	D0		
<b>Noise Blanker Threshold Vpeak = 0.9V</b>									
					0	0	0	V <sub>th</sub> = 30mV	
					0	0	1	V <sub>th</sub> = 35mV	
					0	1	0	V <sub>th</sub> = 40mV	
					0	1	1	V <sub>th</sub> = 45mV	
					1	0	0	V <sub>th</sub> = 50mV	
					1	0	1	V <sub>th</sub> = 55mV	
					1	1	0	V <sub>th</sub> = 60mV	
					1	1	1	V <sub>th</sub> = 65mV	
<b>Noise Blanker Noise Adjusted Threshold Vpeak = 1.4V</b>									
			0	0				V <sub>th</sub> = 140mV	
			0	1				V <sub>th</sub> = 180mV	
			1	0				V <sub>th</sub> = 240mV	
			1	1				V <sub>th</sub> = 280mV	
<b>Gain of Overdeviation Detector Vpeak with MPX of 75KHz Deviation</b>									
	0	0						Detector Off	
	0	1						V <sub>peak</sub> = 1.2Vop	
	1	0						V <sub>peak</sub> = 2.0Vop	
	1	1						V <sub>peak</sub> = 2.8Vop	

## NOISE BLANKER 2

MSB							LSB		FUNCTION
D7	D6	D5	D4	D3	D2	D1	D0		
<b>Field Strength Controlled Rectifier Voltage (control by Vsb-Vr) Vpeak at Vsb-Vr = -500mV (fully Mono)</b>									
						0	0	Control Off	
						0	1	Vpeak = 1.3V	
						1	0	Vpeak = 1.9V	
						1	1	Vpeak = 2.4V	
<b>Noise Blanker Gain</b>									
					1			Low	
					0			High	

## AMS

MSB							LSB		FUNCTION
D7	D6	D5	D4	D3	D2	D1	D0		
<b>Att. Sensitivity Tuning</b>									
						0	0	0dB	
						0	1	-1dB	
						1	0	-2dB	
						1	1	-3dB	
<b>Gain Sensitivity Tuning</b>									
			0	0	0			0dB	
			0	0	1			10dB	
			0	1	0			14dB	
			0	1	1			18dB	
			1	0	0			22dB	
			1	0	1			26dB	
			1	1	0			30dB	
			1	1	1			34dB	
<b>AC Sensitivity Tuning</b>									
	0	0						22dB f = 1.1KHz SW1 = SW2 = SW3	
	0	1						34dB f = 1.1KHz	
	1	0						not allowed	
	1	1						21dB f = 160Hz	
0								AMS ON	
1								AMS OFF	

**DOLBY LEVEL CONTROL**

MSB				LSB				FUNCTION
D7	D6	D5	D4	D3	D2	D1	D0	
								<b>Right Channel</b>
				0	0	0	0	0dB
				0	0	0	1	-0.5dB
				0	0	1	0	-1.0dB
				0	0	1	1	-1.5dB
				0	1	0	0	-2.0dB
				0	1	0	1	-2.5dB
				0	1	1	0	-3.0dB
				0	1	1	1	-3.5dB
				1	0	0	0	-4.0dB
				1	0	0	1	-4.5dB
				1	0	1	0	-5.0dB
				1	0	1	1	-5.5dB
				1	1	X	X	-6.0dB
								<b>Left Channel</b>
0	0	0	0					-0dB
0	0	0	1					-0.5dB
0	0	1	0					-1.0dB
0	0	1	1					-1.5dB
0	1	0	0					-2.0dB
0	1	0	1					-2.5dB
0	1	1	0					-3.0dB
0	1	1	1					-3.5dB
1	0	0	0					-4.0dB
1	0	0	1					-4.5dB
1	0	1	0					-5.0dB
1	0	1	1					-5.5dB
1	1	X	X					-6.0dB

**METAL RESISTANCE CONTROL**

MSB							LSB		FUNCTION
D7	D6	D5	D4	D3	D2	D1	D0		
								<b>Right Channel</b>	
				1	0	0	0	R metal +20%	
				0	0	0	0	R metal +15%	
				0	0	0	1	R metal +10%	
				0	0	1	0	R metal +5%	
				0	0	1	1	R metal =3.8K $\Omega$ Typical	
				0	1	0	0	R metal - 5%	
				0	1	0	1	R metal - 10%	
				0	1	1	0	R metal - 15%	
				0	1	1	1	R metal - 20%	
								<b>Left Channel</b>	
1	0	0	0					R metal +20%	
0	0	0	0					R metal +15%	
0	0	0	1					R metal +10%	
0	0	1	0					R metal +5%	
0	0	1	1					R metal =3.8K $\Omega$ Typical	
0	1	0	0					R metal - 5%	
0	1	0	1					R metal - 10%	
0	1	1	0					R metal - 15%	
0	1	1	1					R metal - 20%	

**PREAMPLIFIER**

MSB							LSB		FUNCTION
D7	D6	D5	D4	D3	D2	D1	D0		
								<b>Attenuation control</b>	
						0	0	0dB	
						0	1	-20dB	
						1	0	-23dB	
						1	1	Mute	
					0			Reverse Mode On	
					1			Forward Mode On	

PINS: 1, 64

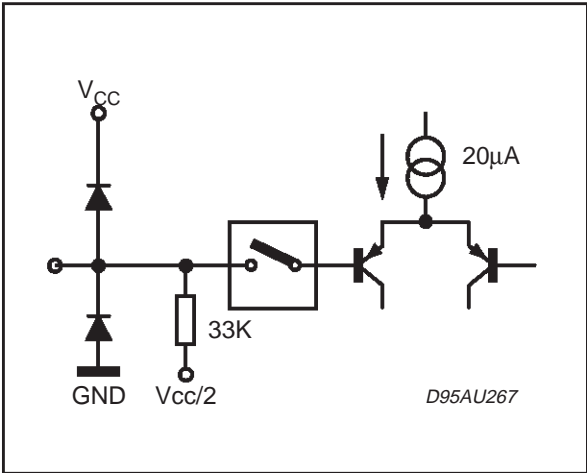

PINS: 2, 3, 6, 7,

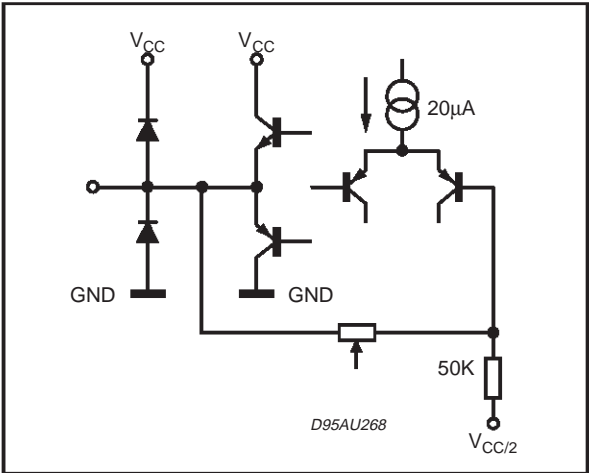

PINS: 40, 50

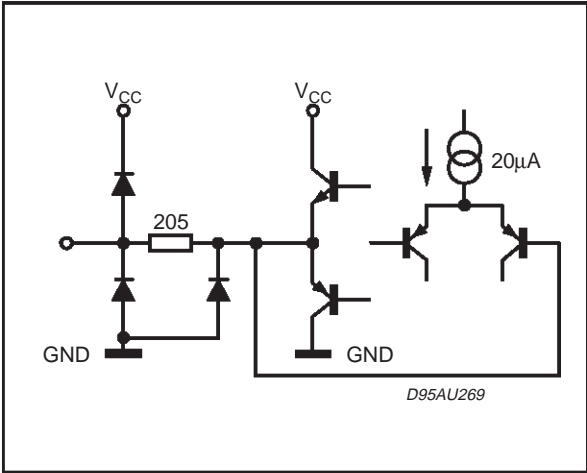

PINS: 8, 9

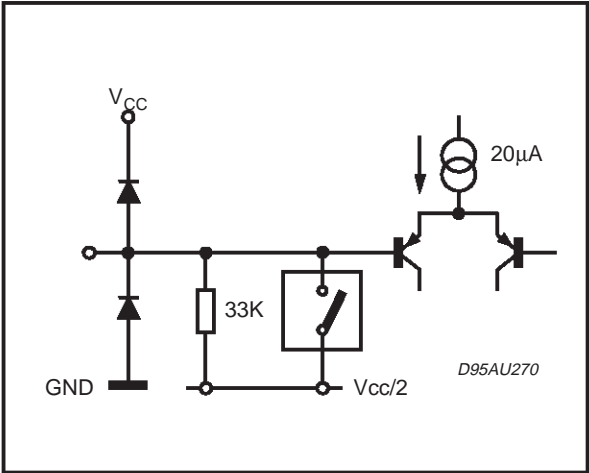

PINS: 10, 12

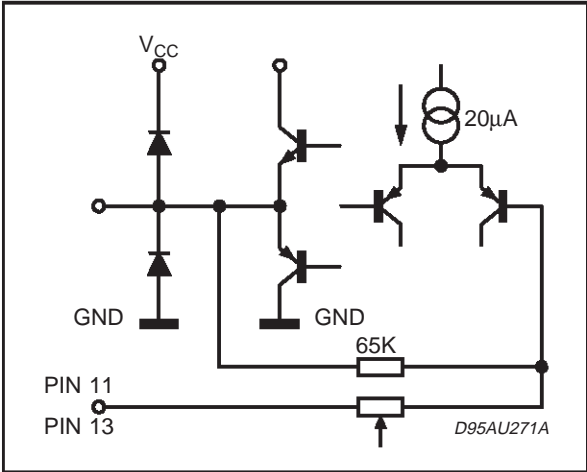

PINS: 11, 13

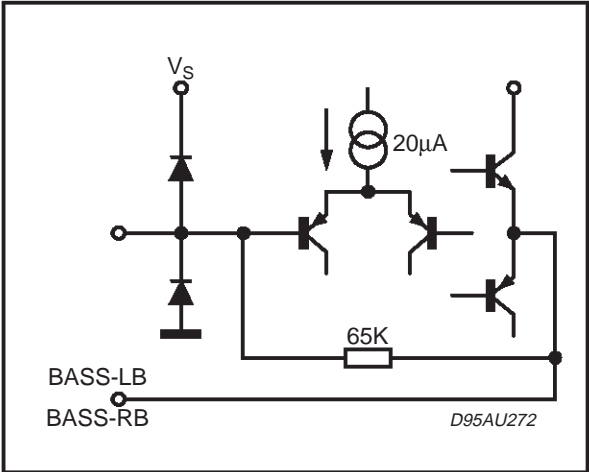

PIN: 15

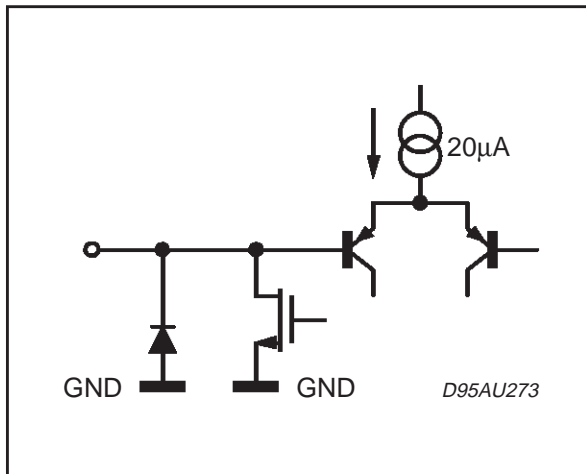

PIN: 16

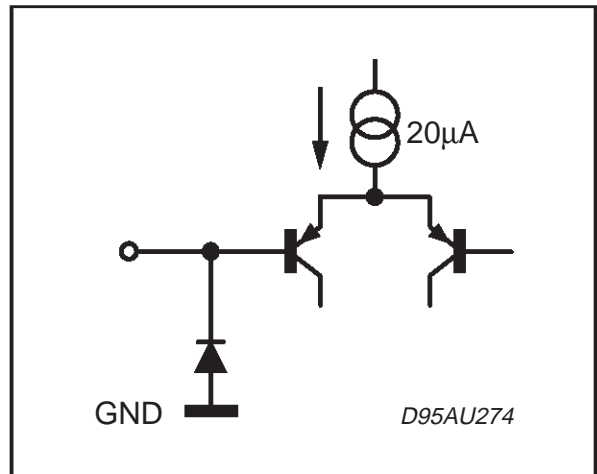

PIN: 19

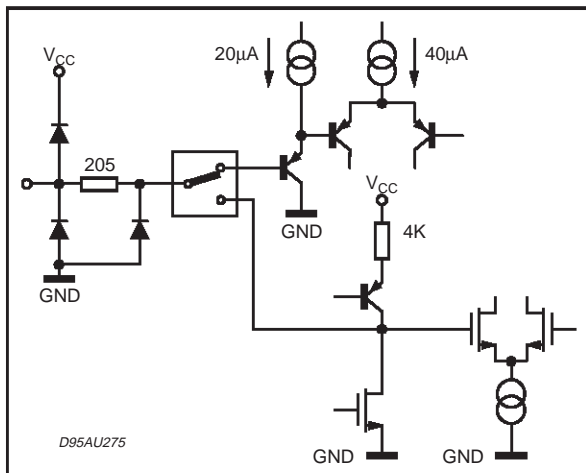

PINS: 20, 21

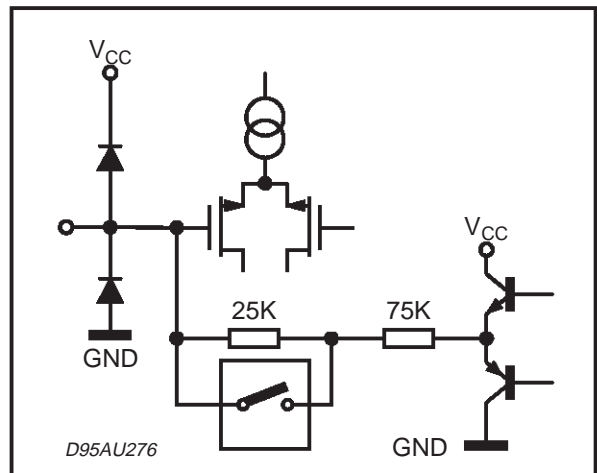

PIN: 22

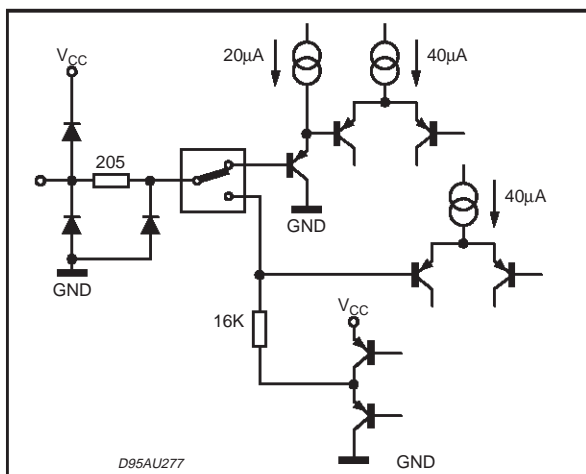

PIN: 23

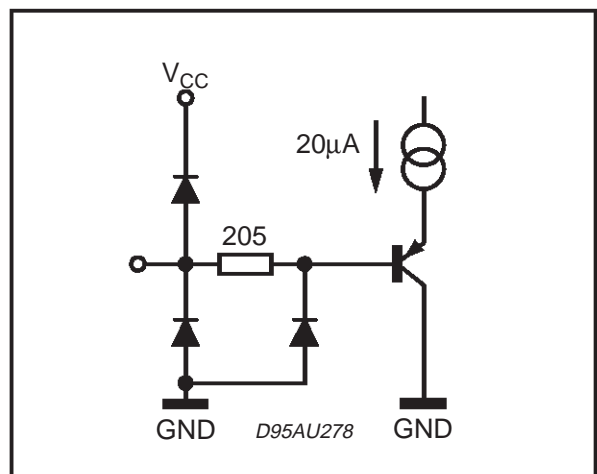



PIN: 24

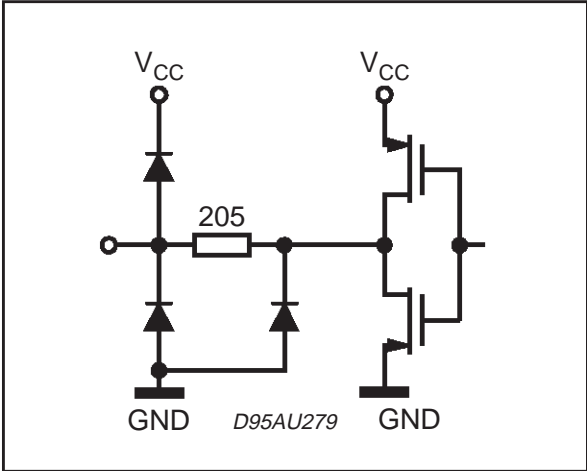

PIN: 25

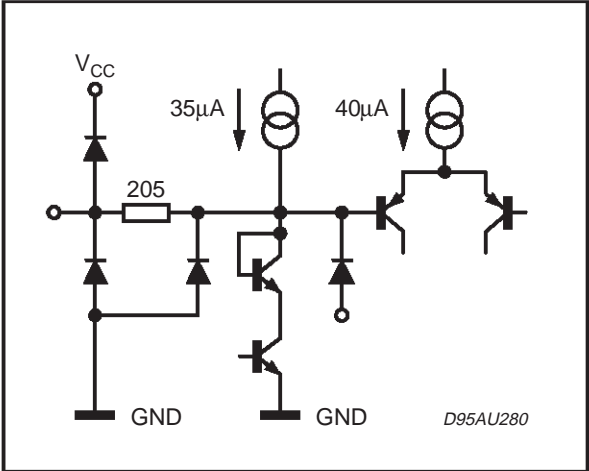

PIN: 26

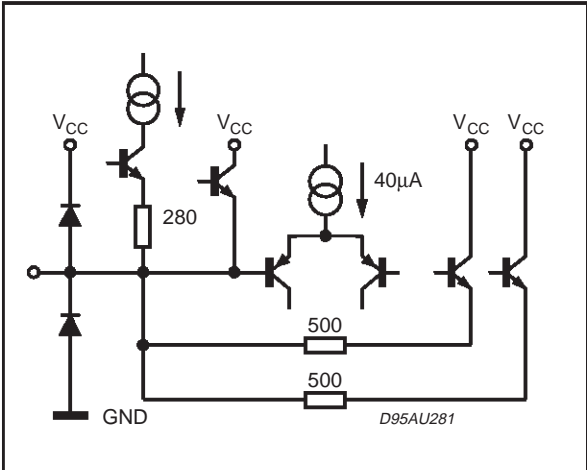

PIN: 27

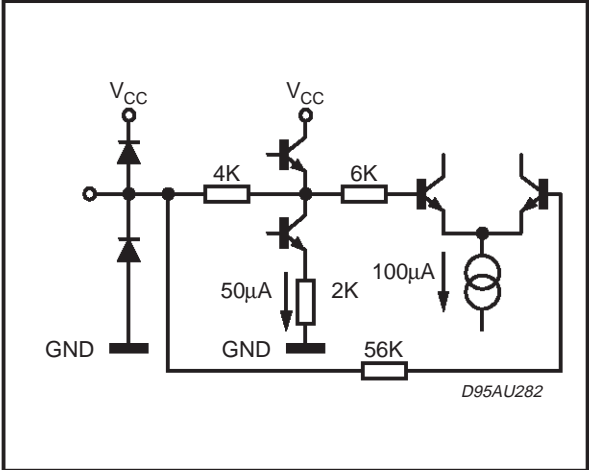

PIN: 28

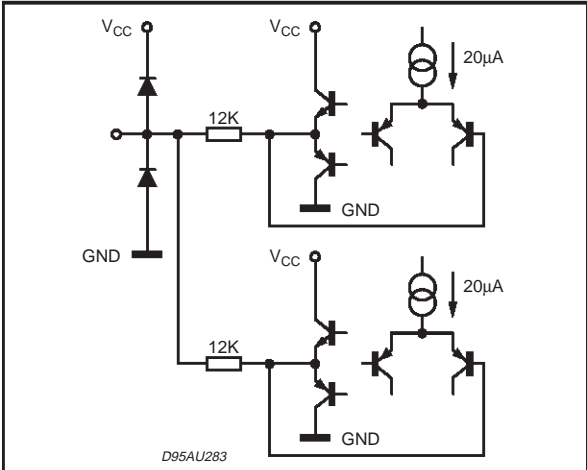

PINS: 29, 56, 57

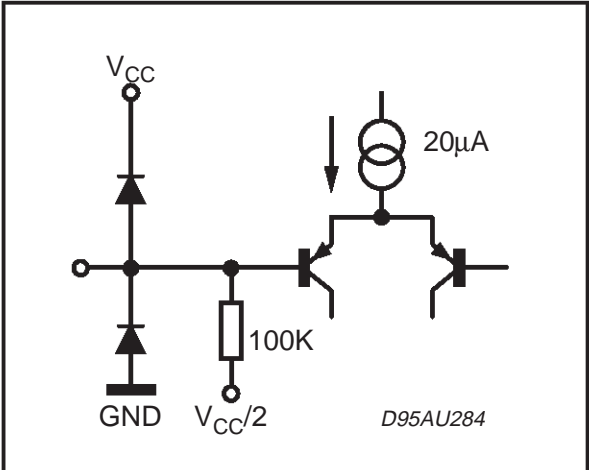



PINS: 39

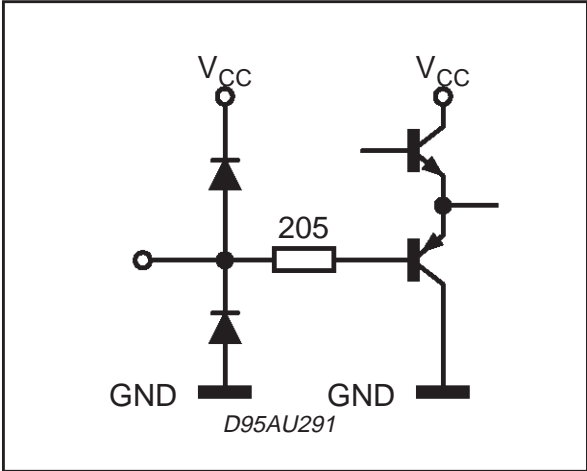

PINS: 41,49

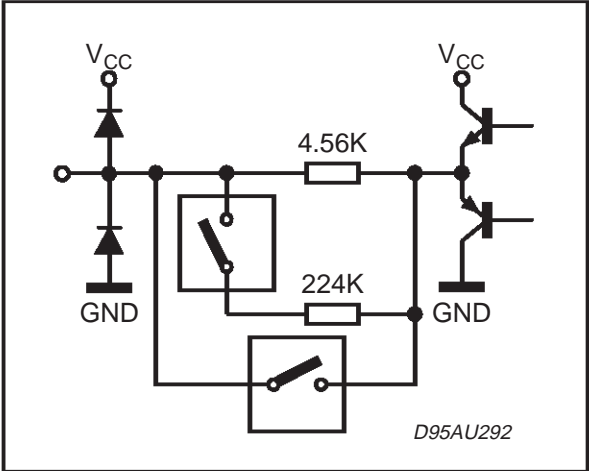

PINS: 42, 48

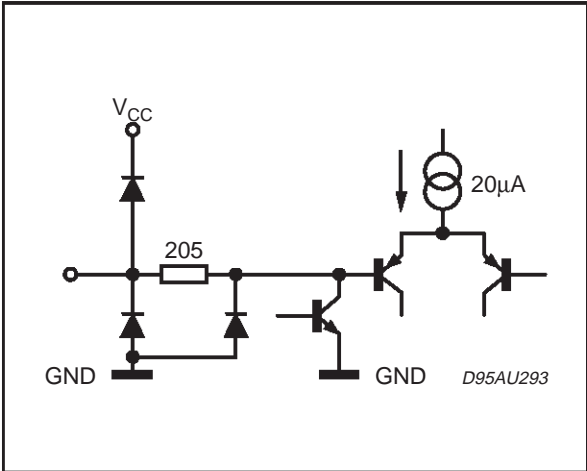

PINS: 43, 44, 46, 47

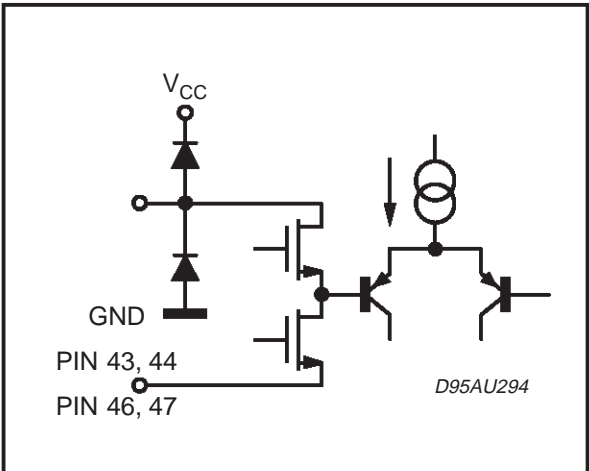

PINS: 52, 53

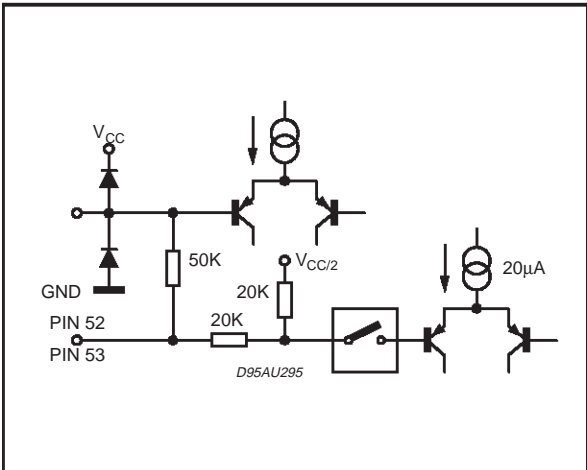

PINS: 54, 55

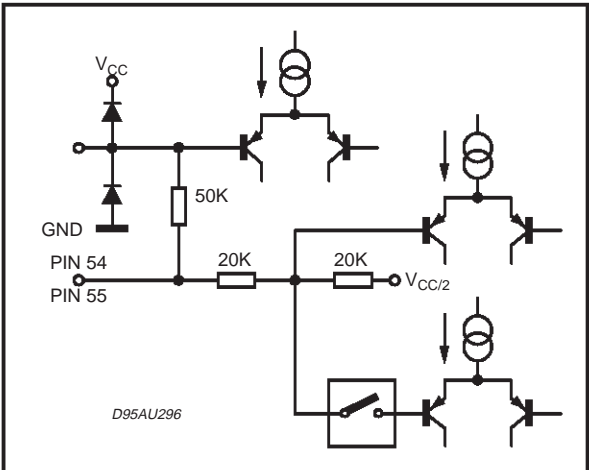

PINS: 58, 60

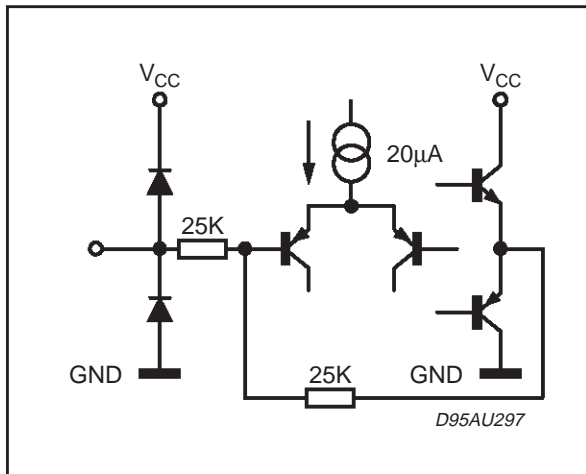

PIN: 59

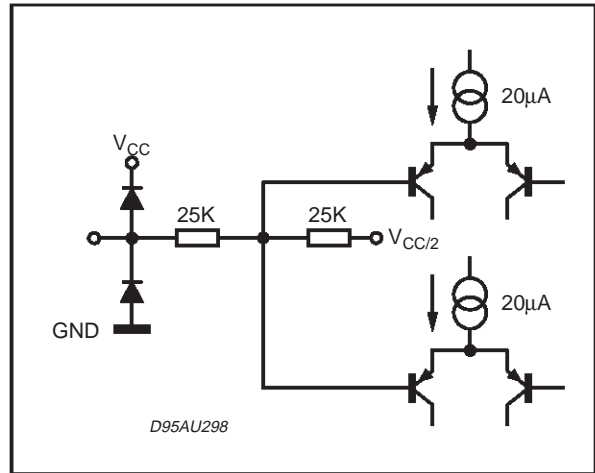

PIN: 61

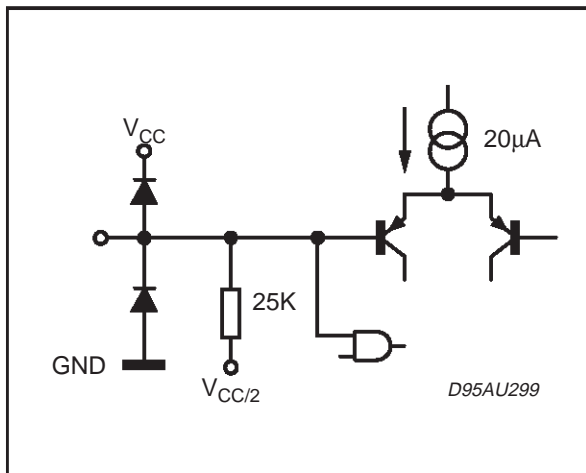

PIN: 62

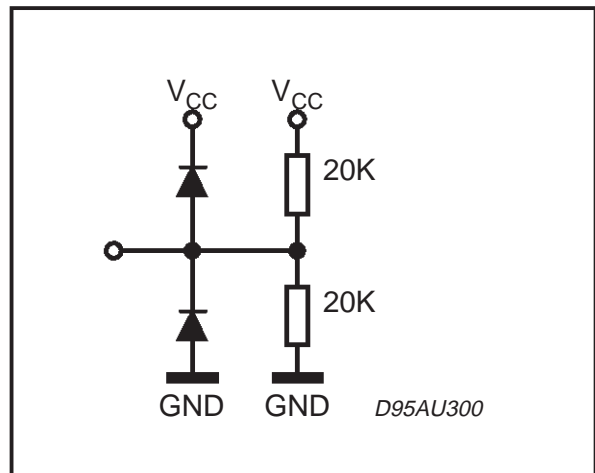

PIN: 63

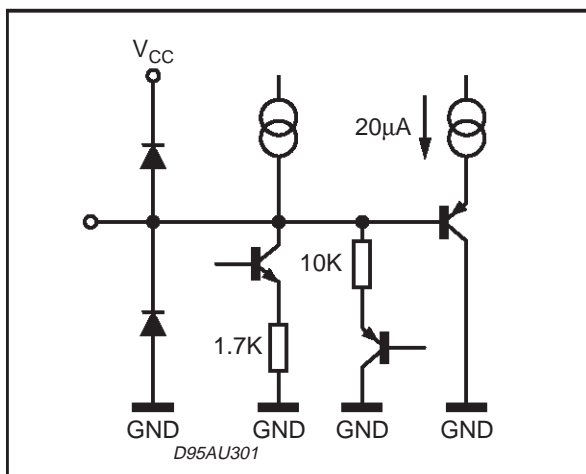

Information furnished is believed to be accurate and reliable. However, STMicroelectronics assumes no responsibility for the consequences of use of such information nor for any infringement of patents or other rights of third parties which may result from its use. No license is granted by implication or otherwise under any patent or patent rights of STMicroelectronics. Specification mentioned in this publication are subject to change without notice. This publication supersedes and replaces all information previously supplied. STMicroelectronics products are not authorized for use as critical components in life support devices or systems without express written approval of STMicroelectronics.

The ST logo is a trademark of STMicroelectronics

© 1998 STMicroelectronics – Printed in Italy – All Rights Reserved

STMicroelectronics GROUP OF COMPANIES

Australia - Brazil - Canada - China - France - Germany - Italy - Japan - Korea - Malaysia - Malta - Morocco - The Netherlands - Singapore - Spain - Sweden - Switzerland - Taiwan - Thailand - United Kingdom - U.S.A.