



SINGLE-CHIP FM/AM TUNER WITH STEREO DECODER AND AUDIO PROCESSOR

1 FEATURES

- AM/FM WORLD TUNER FOR CAR-RADIO
- INTEGRATED IMAGE REJECTION FM MIXER
- INTEGRATED TUNING PLL
- VARIABLE-BANDWIDTH FM IF FILTER (ISS)
- FULLY INTEGRATED FM STEREO DECODER
- FULLY INTEGRATED FM/AM NOISE BLANKER
- HIGHLY INTEGRATED AUDIO PROCESSOR

2 DESCRIPTION

The TDA7514 is a device for car-radio applications that combines full RF front-end functions with advanced audio-processing capabilities.

As far as FM and AM functions are concerned, the TDA7514 features front-end processing, including the digital tuning PLL. IF processing with demodulation and variable-bandwidth IF filtering (ISS), stop station and quality detection functions, FM stereo decoding by means of a fully integrated adjustment-free dedicated PLL and, finally, AM and FM noise blanking (AM noise blanking comprises one IF NB as well as an audio NB).

The FM stereo decoder and the noise blanking functions are realised entirely without external components. The FM front-end circuit features an image-rejection mixer that allows the simplification of the external preselection filter, and a very low noise level that allows getting rid of the external preamplifier with no loss in sensitivity. A 6 bit on-

Figure 1. Package



Table 1. Order Codes

Part Number	Package
E-TDA7514	TQFP80
E-TDA7514TR	TQFP80 in Tape & Reel

E- prefix indicates lead free package

board ADC makes a digitised version of the S-meter available to the μP via $I^2\text{C}$ bus.

The audio processor section comprises input selectors for one stereo single-ended source, one stereo quasi-differential source and a mono differential source. Volume, loudness, tone (bass and treble), balance and fading controls are available with completely pop-free operation to drive four output channels. An additional input independently mixable on each of the four outputs is provided for chime. A soft mute function and an RDS mute function are included to handle source change as well as RDS AF search without abrupt changes in the audio level.

Most of the parameters in the front-end section are $I^2\text{C}$ bus-driven and therefore under the control of the car-radio maker. The $I^2\text{C}$ bus allows furthermore the user to realise the full electric alignment of all the external coils.

Figure 2. Block Diagram

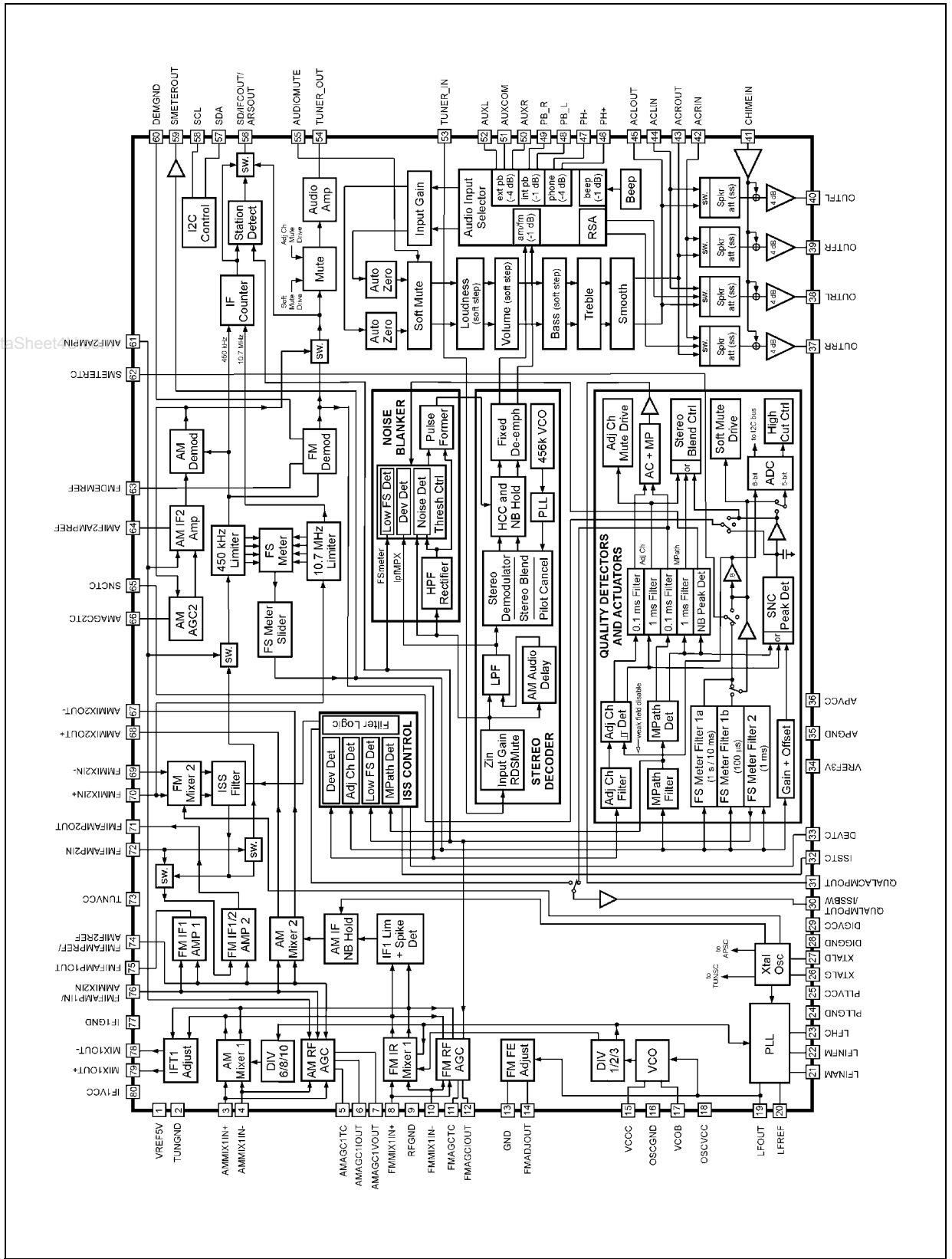

Table 2. Pin Description

N°	Pin	Function
1	VREF5V	5V reference
2	TUNGND	tuner general ground
3	AMMIX1IN+	am mix1 input
4	AMMIX1IN-	am mix1 input
5	AMAGC1TC	am agc1 filter capacitor
6	AMAGC1IOUT	am agc1 current output
7	AMAGC1VOUT	am agc1 voltage output
8	FMMIX1IN+	fm mix1 input
9	RFGND	rf ground
10	FMMIX1IN-	fm mix1 input
11	FMAGCTC	fm agc detector time constant
12	FMAGCIOUT	fm agc current output
13	GND	ground
14	FMADJOUT	fm antenna filter adjustment
15	VCOC	am/fm vco collector
16	OSCGND	vco ground
17	VCOB	am/fm vco base
18	OSCVCC	vco supply (8V)
19	LFOUT	PLL loop filter output
20	LFREF	PLL loop filter reference
21	LFINAM	PLL AM loop filter input
22	LFINFM	PLL FM loop filter input
23	LFHC	PLL loop filter high-current input
24	PLLGND	PLL back-end ground
25	PLLVCC	PLL back-end supply
26	XTALG	ref osc gate
27	XTALD	ref osc drain
28	DIGGND	digital ground
29	DIGVCC	digital dirty supply (8V)
30	QUALMPOUT/ISSBW	multipath det output / ISS BW indicator
31	QUALACMPOUT	multipath det / adjacent channel det output
32	ISSTC	ISS time constant
33	DEVTC	deviation detector time constant
34	VREF3V	3V reference
35	APGND	audio processor/stereo decoder ground
36	APVCC	audio processor/stereo decoder supply (8V)
37	OUTRR	audio out
38	OUTRL	audio out
39	OUTFR	audio out
40	OUTFL	audio out

Table 2. Pin Description

N°	Pin	Function
41	CHIMEIN	chime input
42	ACRIN	ac coupling right input
43	ACROUT	ac coupling right output
44	ACLIN	ac coupling left input
45	ACLOUT	ac coupling left output
46	PH+	phone in +
47	PH-	phone in -
48	PB_L	tape in left
49	PB_R	tape in right
50	AUXR	audio aux in right
51	AUXCOM	audio aux in common
52	AUXL	audio aux in left
53	TUNERIN	am audio/fm mpx input
54	TUNEROUT	am audio/fm mpx output
55	AUDIOMUTE	audio processor mute control
56	SD / IFCOUT / ARSOUT	am/fm station detector output / IF counter output / ARS MPX output
57	SDA	I ² C bus data
58	SCL	I ² C bus clock
59	SMETEROUT	filtered / unfiltered Smeter output
60	DEMGND	fm demodulator ground
61	AMIF2AMPIN	am if2 amp input
62	SMETERTC	am/fm smeter filtering capacitor
63	FMDEMREF	fm demodulator reference capacitor
64	AMIF2AMPREF	am if2 amp feedback capacitor
65	SNCTC	SNC detector time constant
66	AMAGC2TC	am agc2 filter capacitor
67	AMMIX2OUT-	am mix2 output
68	AMMIX2OUT+	am mix2 output
69	FMMIX2IN-	fm mix2 input
70	FMMIX2IN+	fm mix2 input
71	FMIFAMP2OUT	fm if1 amp2 output
72	FMIFAMP2IN	fm if1 amp2 input
73	TUNVCC	tuner general supply (8V)
74	FMIFAMPREF/AMIF2REF	fm if1 amps reference capacitor/am if2 reference voltage
75	FMIFAMP1OUT	fm if1 amp1 output
76	FMIFAMP1IN/AMMIX2IN	fm if1 amp1 input/am mix2 in
77	IF1GND	if1 ground
78	MIX1OUT-	am/fm mix1 output
79	MIX1OUT+	am/fm mix1 output
80	IF1VCC	if1 supply (8V)

3 ELECTRICAL CHARACTERISTICS

3.1 FM

($V_{CC} = 8.5V$; $T_{amb} = 25^{\circ}C$; $V_{ant,in} = 60dB\mu_{load}$; $f_c = 98.1MHz$; $f_{dev} = 40kHz$; $f_{mod} = 1kHz$; $IF1_{amp1} = 25dB$; $IF1_{amp2} = 15dB$; Filter @TUNEROUT:IEC_TUNER+Deemphasis=50 μs , unless otherwise specified)

Table 3.

Symbol	Parameter	Test Condition	Min	Typ	Max	Unit
General (measured at audioprocessor output with de-emphasis and high cut active, ISS set to 80 KHz BW)						
US	Usable sensitivity	S/N=40dB		0		$dB\mu V_{load}$
SNR	Signal to Noise ratio			65		dB
LS	Limiting Sensitivity	-3dB_point, SoftMute Off		-2.5		$dB\mu V_{load}$
THD	Total Harmonic Distortion	$f_{dev} = 40kHz$		0.26		%
		$f_{dev} = 75kHz$		0.36		%
Vout	Output Level	@TUNEROUT		243		mV_{rms}
ISN	Interstation Noise	Delta Vout@RF OFF, Soft Mute OFF		-8.5		dB
IFCS	IF Counter Sensitivity			0		$dB\mu V_{load}$
Icctun	DC Supply Current@TUNVCC			80		mA
Iccmix1	DC Supply Current@IFT1			5		mA
Iccif1	DC Supply Current@IF1VCC			10		mA
Iccosc	DC Supply Current@OSCVCC			10		mA
Iccpll	DC Supply Current@PLLVCC			3		mA
Iccdig	DC Supply Current@DIGVCC			7		mA
IQ Mixer 1						
RIN	Input Resistance	Differential		6		$k\Omega$
VIN	Input DC Bias	@pin 8, pin 10		2.3		V
Gm	Transconductance			17		mS
IIP3	Input IP3			108		$dB\mu V$
IQG	IQ Gain Adjustment		-1		+1	%
IQP	IQ Phase Adjustment		-7		+8	$^{\circ}C$
IRR	Image Rejection Ratio	without adjustment	30			dB
		adjusted		42		dB
Gvmix1	Gain	from input (single-ended) to IFT1 out differential		22		dB
IFT1 Adjustment						
Cift1 min	IFT1 Adjustment Capacitor Minimum	Between MIX1OUT+ and MIX1OUT-		2.3		pF

Table 3. (continued)

Symbol	Parameter	Test Condition	Min	Typ	Max	Unit
Cift1max	IFT1 Adjustment Capacitor Maximum	Between MIX1OUT+ and MIX1OUT-		20.1		pF
Cift1step	IFT1 Adjustment Capacitor Step	Between MIX1OUT+ and MIX1OUT-		1.3		pF
RFT Adjustment						
Vrftadjmin	RFT Adjustment Minimum	@ T6<0:7>=[00000000] TVIN=3V		0.4		V
Vrftadjmax	RFT Adjustment Maximum	@ T6<0:7>=[11111111] TVIN=3V		5.9		V
Vrftadjstep	RFT Adjustment Step	TVIN=3V, VRFTadjstep=TVIN/128		23		mV
VRFT0		@ T6<0:7>=[11000001] TVIN=3V		3		V
Voutmax	Output voltage maximum	VCC-0.4		8.1		V
Voutmin	Output voltage minimum			0.4		V
Wide Band RF AGC (input: FMMIXER1in+ and FMMIXER1IN-)						
WAGCspL	Lower Threshold Start (Set 1) ("min" not used)	Level at FMMIXER1IN+ @V12=100mV IFT1 primary is shorted and is connected to GND with 56nF		66.8		dB μ V
WAGCspH	Higher Threshold Start (Set max)	Level at FMMIX1IN+ @V12=100mV IFT1 primary is shorted and is connected to GND with 56nF		83.5		dB μ V
Wide Band Keying AGC (Controlled by FiltSMeter1ms)						
WAGCK	AGC Start (Set 1) shift	Shifted level of AGC Starting point at FMMIX1IN+ when VSMeter changes from Vkey to Vkey-450mV		-12		dB
Vkey	Vsmeter at Keyed AGC start	when V12 changes to 90mV from 100mV (Set 1)		1.71		V
Narrow Band IF AGC (input: FMMIXEROUT+ and FMMIXER1OUT-)						
NAGCspL	Lower Threshold Start (Set 1) ("min" not used)	Level of IF1 at FMMIX1OUT+ @V12=100mV		90.2		dB μ V
NAGCspH	Higher Threshold Start (Set max)	Level of IF1 at FMMIX1OUT+ @V12=100mV WAGC set to max		109		dB μ V
RF AGC Pin Diode Driver Out						
Ioutmin	Minimum	AGCOFF			0.1	μ A
Ioutmax	Maximum	AGCON; total @ 330 Ω @ 2.2K Ω		10.1 8.8 1.35		mA mA mA

Table 3. (continued)

Symbol	Parameter	Test Condition	Min	Typ	Max	Unit
FMIF1AMP1 and FMIF1AMP2						
Gv1min	AMP1 Minimum Gain	Source and load impedance: 330ohm.		19		dB
Gv1max	AMP1 Maximum Gain	Source and load impedance: 330ohm.		25		dB
IIP3a1	AMP1 input-referred IP3			TBD		dB μ V
Rin1	Input Impedance of AMP1			330		Ω
Rout1	Output Impedance of AMP1			330		Ω
Gv2min	AMP2 Minimum Gain	Source and load impedance: 330ohm.		7		dB
Gv2max	AMP2 Maximum Gain	Source and load impedance: 330ohm.		15		dB
IIP3a2	AMP2 input-referred IP3			TBD		dB μ V
Rin2	Input Impedance of AMP2			330		Ω
Rout2	Output Impedance of AMP2			330		Ω
FMMIXER2 (output not accessible)						
Gvmix2	Gain (Single-ended output)	Source impedance: 330ohm.		12.3		dB
Rinmix2	Input Impedance			330		Ω
FMLIMITER (450KHz) (output not accessible)						
Gvlim	Gain (To Demod_IN from FMMIXER2out+)			TBD		dB
FM Filtered Smeter (Mod:off , Slider: 0)						
VFSM1	Filtered Smeter1	@FMMIX2IN=50dB μ V		1.44		V
VFSM2	Filtered Smeter2	@FMMIX2IN=70dB μ V		2.47		V
VFSM3	Filtered Smeter3	@FMMIX2IN=90dB μ V		3.96		V
FSMR1	Filtered Smeter resistor	T16<5>= 0		200		k Ω
FSMR2	Filtered Smeter resistor	T16<5>= 1		21		M Ω
CLVFSM	Clamped voltage			5		V
TCsm1	Time constant1	T16<5>= 0		10		ms
TCsm2	Time constant2	T16<5>= 1		0.9		s
FM Smeter Slider						
SLSTEP	Slider step			38		mV
SLMAX	Maximum Slider	@VFSM=2.6V		1.16		V
SLMIN	Minimum Slider	@VFSM=2.6V		-1.18		V
ISS (Intelligent Selectivity System) Filter						
Fcenter	Center Frequency			450		kHz

Table 3. (continued)

Symbol	Parameter	Test Condition	Min	Typ	Max	Unit
Fc120BW3	Fcenter=120KHz, @-3dB,BW	@ISS 120KHz		120		kHz
Fc120BW20	Fcenter=120KHz, @-20dB,BW	@ISS 120KHz		250		kHz
Fc80BW3	Fcenter=80KHz, @-3dB,BW	@ISS 80KHz		80		kHz
Fc80BW20	Fcenter=80KHz, @-20dB,BW	@ISS 80KHz		150		kHz
Fc20BW3	Fcenter=20KHz, @-3dB,BW	@ISS 20KHz		25		kHz
Fc20BW20	Fcenter=20KHz, @-20dB,BW	@ISS 20KHz		75		kHz
ΔFmin	Fcenter Fine adjust minimum			-20		kHz
ISS Filter Time Constant						
Icha1	Charge current low	@Weak adjacent		60		μA
Icha1	Charge current high	@Weak adjacent		74		μA
Icha2	Charge current low	@Strong adjacent		110		μA
Icha2	Charge current high	@Strong adjacent		124		μA
Idischa	Discharge current low			1		μA
Idischa1	Discharge current high			15		μA
VISSTCL	ISSTC Low			0.1		V
VISSTCH	ISSTC High			4.9		V
ISS Filter Switch Threshold						
V120on	Threshold for ISS120on			3		V
V120off	Threshold for ISS120off			1		V
V80on	Threshold for ISS80on			4		V
V80off	Threshold for ISS80off			2		V
Adjacent Channel detector for ISS (input: Smeter unfiltered)						
FcenterAC1	Filter1 cutoff, T22<1:0>=00	HP(106KHz)+HP(100KHz)		130		kHz
FcenterAC2	Filter2 center, T22<1:0>=01	BP(100KHz)+HP(144KHz)		100		kHz
FcenterAC3	Filter3 center, T22<1:0>=10	BP(204KHz)+BP(100KHz)		177		kHz
FcenterAC4	Filter4 center, T22<1:0>=11	BP(100KHz)+BP(144KHz)		101		kHz
Gacmin	Gain minimum			23		dB
Gacmax	Gain maximum			29		dB
Vacl	Output voltage low			3.0		V
Vach	Output voltage high			4.9		V
Vthacl	Threshold for weak adjacent low			3.25		V
Vthach	Threshold for weak adjacent high			3.95		V

Table 3. (continued)

Symbol	Parameter	Test Condition	Min	Typ	Max	Unit
Vthacstep	Threshold for weak adjacent step			100		mV
Δ ACI	Differential Vthreshold between weak and strong adjacent low			0		mV
Δ ACH	Differential Vthreshold between weak and strong adjacent high			300		mV
Δ ACstep	Differential Vthreshold between weak and strong step			100		mV
ACdesen1	Desens Th1	Vsmeter at starting desens		0.25		V
ACdesen2	Desens Th2	Vsmeter at starting desens		0.83		V
ACdesen3	Desens Th3	Vsmeter at starting desens		1.42		V
ACdesen4	Desens Th4	Vsmeter at starting desens		2.0		V
Slop1	Δ AC/ Δ Vsmeter1	T22<6:5>=00		-2.7		
Slop2	Δ AC/ Δ Vsmeter2	T22<6:5>=01		-3.3		
Slop3	Δ AC/ Δ Vsmeter3	T22<6:5>=10		-5		
Slop4	Δ AC/ Δ Vsmeter4	T22<6:5>=11		-10		
Multipath Channel detector for ISS (input: Smeter unfiltered+Buffer)						
FcenterMP	BPF center			19		kHz
Qmp	Quality factor of BPF			8.5		
FiltGv1	Gain1 of BPF	T25<1:0>=00		-7		dB
FiltGv2	Gain2 of BPF	T25<1:0>=01		4		dB
FiltGv3	Gain3 of BPF	T25<1:0>=10		7		dB
FiltGv4	Gain4 of BPF	T25<1:0>=11		10		dB
Grect1	Rectifier Gain1	T25<3:2>=00		6		dB
Grect2	Rectifier Gain2	T25<3:2>=01		12		dB
Grect3	Rectifier Gain3	T25<3:2>=10		18		dB
Grect4	Rectifier Gain4	T25<3:2>=11		22		dB
Vmpl	Output voltage low			3.0		V
Vmph	Output voltage high			4.9		V
Vthmp1	Threshold level1			3.49		V
Vthmp2	Threshold level2			3.74		V
Vthmp3	Threshold level3			4.06		V
Vthmp4	Threshold level4			4.31		V
Deviation detector for ISS (input: Demodulator output)						
FcDev	Cutoff Frequency of MPX LPF (2 nd order)			10		kHz

Table 3. (continued)

Symbol	Parameter	Test Condition	Min	Typ	Max	Unit
Gvlpf	Gain of LPF			14		dB
Idischarl	discharge current low at DEVTC			6		μ A
Idischarh	discharge current high at DEVTC			20		μ A
Idischarstep	discharge current step at DEVTC			2		μ A
Vth1	Low threshold1			15		kHz _{dev}
Vth2	Low threshold2			20		kHz _{dev}
Vth3	Low threshold3			28		kHz _{dev}
Vth4	Low threshold4			44		kHz _{dev}
Rdev1	Ratio of Vthreshold between strong and high deviation	Vthhighdev/Vthdev		1		
Rdev2	Ratio of Vthreshold between strong and high deviation	Vthhighdev/Vthdev		1.3		
Rdev3	Ratio of Vthreshold between strong and high deviation	Vthhighdev/Vthdev		1.4		
Rdev4	Ratio of Vthreshold between strong and high deviation	Vthhighdev/Vthdev		1.5		
DEVdesens1	Offset1 for Vsoftmute for desens	referred to soft mute threshold		50		mV
DEVdesens2	Offset2 for Vsoftmute for desens	referred to soft mute threshold		150		mV
Field Strength ISS (FSISS)						
Δ Vthisissl	Low offset for Vthsm of softmute by Smeter(1ms)	referred to soft mute threshold		-467		mV
Δ Vthisissh	High offset for Vthsm of softmute by Smeter(1ms)	referred to soft mute threshold		+467		mV
Δ Vthisissstep	Step offset for Vthsm of Softmute by Smeter(1ms)			67		mV
SoftMute by Smeter						
Vthsm1	Threshold level1	T14<1:0>=00		0.3		V
Vthsm2	Threshold level2	T14<1:0>=01		0.4		V
Vthsm3	Threshold level3	T14<1:0>=10		1.6		V
Vthsm4	Threshold level4	T14<1:0>=11		1.8		V
Attsmmax	Maximum attenuation			21.5		dB
Attsmmin	Minimum attenuation			4.5		dB
Attsmstep	Step attenuation			2.5		dB

Table 3. (continued)

Symbol	Parameter	Test Condition	Min	Typ	Max	Unit
SoftMute by Adjacent Channel Detector						
Vthsmac1	Threshold level1	T14<2>=0		2.75		V
Vthsmac2	Threshold level2	T14<2>=1		3.25		V
Attsmac1	Attenuation1	T14<7:6>=00		0		dB
Attsmac2	Attenuation2	T14<7:6>=01		6		dB
Attsmac3	Attenuation3	T14<7:6>=10		9		dB
Attsmac4	Attenuation4	T14<7:6>=11		12		dB
Station Detector by Smeter						
VSDl	Low output level	@SDpin		0		V
VSDh	High output level	@SDpin		5		V
Vthsdmin	Threshold level minimum	T20<3:0>=0000		0.4		V
Vthsdmax	Threshold level maximum	T20<3:0>=1111		3.4		V
Vthsdstep	Threshold level step			0.2		V
Adjacent Channel Detector for Quality outputs, SNC and HCC						
F1ac1	Cutoff or center frequency of filter1	T8<4>=0		83		kHz
F1ac2	Cutoff or center frequency of filter1	T8<4>=1		104		kHz
F2ac1	Cutoff or center frequency of filter2	T8<5>=0		119		kHz
F2ac2	Cutoff or center frequency of filter2	T8<5>=1		139		kHz
GcF2ac1	Gain of filter2	T18<7>=0		8.7		dB
GcF2ac2	Gain of filter2	T18<7>=1		14.7		dB
ΔVrect1	Offset1 of rectifier for SNC&HCC	T18<5:4>=00		0.4		V
ΔVrect2	Offset2 of rectifier for SNC&HCC	T18<5:4>=01		0.8		V
ΔVrect3	Offset3 of rectifier for SNC&HCC	T18<5:4>=10		1.2		V
ΔVrect4	Offset4 of rectifier for SNC&HCC	T18<5:4>=11		1.6		V
Multipath Detector for Quality output, SNC and HCC (Filter shared with ISS multipath detector)						
Gvrectl	Rectifier Gain minimum	T15<7:5>=000		5		dB
Gvrecth	Rectifier Gain maximum	T15<7:5>=111		13.4		dB
Gvrectstep	Rectifier Gain step			1.2		dB

Table 3. (continued)

Symbol	Parameter	Test Condition	Min	Typ	Max	Unit
Smeter Control for SNC and HCC						
Gvsmi	Gain minimum	T15<3:0>=000		0		dB
Gvsmh	Gain maximum	T15<3:0>=111		2.25		dB
Gvsmstep	Gain step			0.15		dB
Quality_ACMPout (High output corresponds to good quality)						
Gqacmp1mp	Gain output level1 for multipath	T25<5:4>=01		-4		dB
Gqacmp2mp	Gain output level2 for multipath	T25<5:4>=10		0		dB
Gqacmp3mp	Gain output level3 for multipath	T25<5:4>=11		+4		dB
Gqacmp4mp	Gain output level4 for multipath	T25<5:4>=00		-60		dB
Gqacmp1ac	Gain output level1 for adjacent channel	T25<7:6>=01		-4		dB
Gqacmp2ac	Gain output level2 for adjacent channel	T25<7:6>=10		0		dB
Gqacmp3ac	Gain output level3 for adjacent channel	T25<7:6>=11		+4		dB
Gqacmp4ac	Gain output level4 for adjacent channel	T25<7:6>=00		-60		dB
Vqacmpmax	Maximum output level			5.0		V
Vqacmpmin	Minimum output level			0		V
Quality_MPout (Low output corresponds to good quality)						
Vqacmax	Maximum output level			5		V
Vqacmin	Minimum output level			0.9		V
Roll off compensation for TUNEROUT						
ΔV_{c120}	Delta voltage between ISS120 ON and ISS OFF	@53KHz		1		dB
ΔV_{c80}	Delta voltage between ISS80 ON and ISS OFF	@53KHz		1		dB
Weather Band Audio Gain Boost						
Gvwbbst	Boosted gain			23.5		dB

3.2 AM

($V_{cc} = 8.5V$; $T_{amb} = 25^{\circ}C$; $V_{sg} = 74dB_{\mu V_{emf}}$; $f_c = 999KHz$; Modulation level = 30%, $f_{mod} = 400Hz$; $800+20pF/65pF$ dummy antenna; Filter@TUNEROUT: IEC_TUNER + Deemphasis = 50us, unless otherwise specified).

Table 4.

Symbol	Parameter	Test Condition	Min	Typ	Max	Unit
General (input level @SG emf)						
US	Usable sensitivity	SNR=20dB		26		$dB_{\mu V_{emf}}$
SNR	Signal to Noise Ratio			50		dB
MS	Maximum Sensitivity	@ $\Delta V_{out}=-10dB$, SoftMute:off		20		$dB_{\mu V_{emf}}$
THD1	Total Harmonic Distortion1	mod=30%, VSG=74 $dB_{\mu V_{emf}}$		0.1		%
THD2	Total Harmonic Distortion2	mod=80%, VSG=74 $dB_{\mu V_{emf}}$		0.2		%
THD3	Total Harmonic Distortion3	mod=30%, VSG=120 $dB_{\mu V_{emf}}$		0.2		%
THD4	Total Harmonic Distortion4	mod=80%, VSG=120 $dB_{\mu V_{emf}}$		0.5		%
THDLF	THD @ Low frequency	mod=30%, $f_{mod}=100Hz$		0.2		%
Vout	Level of TUNEROUT	TUNEROUT		370		mV_{rms}
ISN	Interstation noise level	Vout @RF:off & SoftMute:off		-35		dB
IFCS	IF Counter Sensitivity			10		$dB_{\mu V_{emf}}$
Icctun	DC Supply Current@TUNVCC			85		mA
Iccmix1	DC Supply Current@IFT1			5		mA
Iccif1	DC Supply Current@IF1VCC			10		mA
Iccmix2	DC Supply Current@IFT2			2		mA
Iccosc	DC Supply Current@OSCVCC			8		mA
Iccpll	DC Supply Current@PLLVCC			5		mA
Iccdig	DC Supply Current@DIGVCC			10		mA
MIXER1						
Gv	Conversion gain	From AMMIXER1IN+ to IFT1; secondary loaded with 330 Ω		3.5		dB
Rin	Input resistance (differential)			1		$K\Omega$
IIP3mix1	Input-referred IP3			130		$dB_{\mu V}$
AGC1 Wide Band AGC (input: AMMIXER1in+ and AMMIXER1IN-; FEAGC in open-loop configuration)						
WAGCspl	Starting point minimum	Level at AMMIX1IN+ @IAGCOUT = 1 μA , RF=999KHz, Set=0		94.4		$dB_{\mu V}$
WAGCsph	Starting point maximum	Level at AMMIX1IN+ @IAGCOUT = 1 μA , RF=999KHz, Set=31		115.5		$dB_{\mu V}$

Table 4. (continued)

Symbol	Parameter	Test Condition	Min	Typ	Max	Unit
AGC1 Narrow Band AGC (input: AMMIXER2in; FEAGC in open-loop configuration)						
NAGCspl	Starting point minimum	Level at AMMIX2IN @ IAGCOUT = 1µA IF1=10.7MHz, Set=0		96.3		dBµV
NAGCsph	Starting point maximum	Level at AMMIX2IN @ IAGCOUT = 1µA IF1=10.7MHz, Set=31		117.0		dBµV
AGC1 Ultra Narrow Band AGC (input: AMIF2IN+; FEAGC in open-loop configuration)						
UNAGCspl	Starting point minimum	Level at AMIF2IN @ IAGCOUT = 1uA IF2=450KHz, Set=0		69.6		dBµV
UNAGCsph	Starting point maximum	Level at AMIF2IN @ IAGCOUT = 1uA IF2=450KHz, Set=15		76.9		dBµV
AGC1 Output						
Ioutl	Pindiode drive current minimum	AGCOFF			1	µA
Iouth	Pindiode drive current maximum	AGCON	0.4			mA
Voutl	Rfamp control voltage minimum	AGCON			0.5	V
Vouth	Rfamp control voltage maximum	AGCOFF		3.5		V
Ragcvout	Output resistance at VOUT			17		kΩ
AGC1 Time Constant						
Ragc1tc1	Time constant FAST mode	Output resistance AMAGC1TCpin		9		kΩ
Ragc1tc2	Time constant Normal mode	Output resistance AMAGC1TCpin		100		kΩ
AMMIXER2						
Gmix2max	Conversion Gain	From AMMIXER2in to IFT2 secondary loaded with 2kΩ		8		dB
IIP3mix2	Input-referred IP3			140		dBµV
Rmix2in	Input resistance			2.4		kΩ
AMIF2amplifier						
Gif2ampmin	min. gain , no AGC2	T29<7:4>=0010		68		dB
Gif2ampmax	max. gain , no AGC2	T29<7:4>=1111		82		dB
Δ Gif2amp	AGC2 range			-40		dB
Rif2ampin	Input resistance			2		kΩ
SoftMute by Smeter						
Vthsm1	Threshold level1	T14<1:0>=00		0.3		V

Table 4. (continued)

Symbol	Parameter	Test Condition	Min	Typ	Max	Unit
Vthsm2	Threshold level2	T14<1:0>=01		0.4		V
Vthsm3	Threshold level3	T14<1:0>=10		1.6		V
Vthsm4	Threshold level4	T14<1:0>=11		1.8		V
Attsmmax	Maximum attenuation			21.5		dB
Attsmmin	Minimum attenuation			4.5		dB
Attsmstep	Step attenuation			2.5		dB
AM Filtered Smeter						
VFSM1	Filtered Smeter1	@ AMIF2AMPIN=50dB μ V		0.8		V
VFSM2	Filtered Smeter2	@ AMIF2AMPIN=70dB μ V		2.2		V
VFSM3	Filtered Smeter3	@ AMIF2AMPIN=90dB μ V		4.4		V
FSMR1	Filtered Smeter resistor	T16<5>=0		200		k Ω
FSMR2	Filtered Smeter resistor	T16<5>=1		21		M Ω
CLVFSM	Clamped voltage			5		V
TCsm1	Time constant1	T16<5>=0		10		ms
TCsm2	Time constant2	T16<5>=1		0.9		s
AM Smeter Slider						
SLSTEP	Slider step			40		mV
SLMAX	Maximum Slider	@ VFSM=2.6V		1.23		V
SLMIN	Minimum Slider	@ VFSM=2.6V		-1.25		V
AM Station Detector by Smeter						
VSDI	Low output level	@SD pin		0		V
VSDh	High output level	@SD pin		5		V
Vthsdmin	Threshold level minimum	T29<3:0>=0000		0.3		V
Vthsdmax	Threshold level maximum	T29<3:0>=1111		2.55		V
Vthsdstep	Threshold level step			0.15		V
AMAGC2 Time Constant						
Ragc2tc1	Time constant FAST mode	Output resistance AMAGC1TCpin		4.8		k Ω
Ragc2tc2	Time constant Normal mode	Output resistance AMAGC1TCpin		150		k Ω
AMIFNB						
Wgateifnb	Width of gate			12		μ sec
Voffset0	Rectifier offset0	T31<3:0>=0000		0		mV
Voffset1	Rectifier offset1	T31<3:0>=0001		46		mV
Voffset2	Rectifier offset2	T31<3:0>=0010		100		mV
Voffset3	Rectifier offset3	T31<3:0>=0011		146		mV

Table 4. (continued)

Symbol	Parameter	Test Condition	Min	Typ	Max	Unit
Voffset4	Rectifier offset4	T31<3:0>=0100		212		mV
Voffset5	Rectifier offset5	T31<3:0>=0101		257		mV
Voffset6	Rectifier offset6	T31<3:0>=0110		312		mV
Voffset7	Rectifier offset7	T31<3:0>=0111		362		mV
Voffset8	Rectifier offset8	T31<3:0>=1000		439		mV
Voffset9	Rectifier offset9	T31<3:0>=1001		485		mV
Voffset10	Rectifier offset10	T31<3:0>=1010		541		mV
Voffset11	Rectifier offset11	T31<3:0>=1011		587		mV
Voffset12	Rectifier offset8	T31<3:0>=1100		653		mV
Voffset13	Rectifier offset9	T31<3:0>=1101		700		mV
Voffset14	Rectifier offset10	T31<3:0>=1110		755		mV
Voffset15	Rectifier offset11	T31<3:0>=1111		800		mV
Vdesens1	Desens threshold1	T31<5:4>=00		4.4		V
Vdesens2	Desens threshold2	T31<5:4>=01		2.65		V
Vdesens3	Desens threshold3	T31<5:4>=10		1.8		V
Vdesens4	Desens threshold4	T31<5:4>=11		1.4		V

3.3 VCO, PLL AND XTAL OSCILLATOR

Table 5.

Symbol	Parameter	Test Condition	Min	Typ	Max	Unit
VCO						
Fvcomin	Minimum VCO frequency	VCC=8.5V		155		MHz
Fvcomax	Maximum VCO frequency	VCC=8.5V		280		MHz
Vosc	Level of oscillation	@200MHz, (RF=89.3MHz) VCOB , Impedance of active probe is 0.7pF/1MΩ		105		dBμV
Loop Filter Output Voltage						
Vlpoutmin	Minimum LPOUT			0.05		V
Vlpoutmax	Maximum LPOUT	VCC-0.05		8.45		V
Xtal Oscillator						
Vxtal	Oscillation level	@XtalD , with 3pF between XtalD and XtalG, Set to 11.25pF		123.5		dBμV
FXTALmax	Adjustment range maximum			+1.95		kHz
FXTALmin	Adjustment range minimum			-1.60		kHz
FXTALstep	Adjustment range step			124		Hz

3.4 STEREODECODER

Standard Conditions, unless otherwise indicated:

FM: Input at #TUNER_IN = 1 kHz at 450 mVrms, Input Gain setting = 0.5 dB, Deemphasis = 75 μ s, Roll Off Compensation set to give maximum stereo separation (note that this varies with VSBL setting)

AM: Input at #TUNER_IN = 1 kHz at 1 Vrms, Input Gain setting = 0.5 dB

Table 6.

Symbol	Parameter	Test Condition	Min.	Typ.	Max.	Unit
V _{IN}	MPX Input Level	Input Gain = 3.5dB		0.5	1.25	V _{RMS}
R _{in}	Input Resistance (TUNERIN)	FM	70	100	130	k Ω
		AM		30		k Ω
Gain	Minimum Input Gain			0.5		dB
G _{max}	Maximum Input Gain			5.75		dB
G _{STEPom}	Step Resolution			1.75		dB
a	Max Channel Separation		30	50		dB
SVRR	Supply Voltage Ripple Rejection	Vripple=100mV, f=1kHz	35	55		dB
THD	Total Harmonic Distortion	f _{in} =1kHz, mono		0.02	0.3	%
S+N N	Signal plus Noise to Noise Ratio	A-weighted, S=2Vrms	80	91		dB
MONO/STEREO SWITCH (With InGain=5.75dB)						
V _{PTHST1}	Pilot Threshold Voltage	for Stereo, PTH=1	10	15	25	mV
V _{PTHST0}	Pilot Threshold Voltage	for Stereo, PTH=0	15	25	35	mV
V _{PTHMO1}	Pilot Threshold Voltage	for Mono, PTH=1	7	12	17	mV
V _{PTHMO0}	Pilot Threshold Voltage	for Mono, PTH=0	10	19	25	mV
PLL						
$\Delta f/f$	Capture Range		0.5			%
DEEMPHASIS & HIGHCUT						
$\tau_{DeempFM}$	Deemphasis Time Constants FM; V _{LEVEL} >> V _{HCH}	Deemphasis=50 μ s, FM	25	50	75	μ s
		Deemphasis=75 μ s, FM	50	75	100	μ s
$\tau_{DeempAM}$	Deemphasis Time Constants AM; V _{LEVEL} >> V _{HCH}	Deemphasis=50 μ s, AM		22.3		kHz
		Deemphasis=75 μ s, AM		14.9		kHz
REF5V	Internal Reference Voltage		4.7	5	5.3	V
Carrier and Harmonic suppression at output						
α_{19}	Pilot Signal	f=19kHz, Deemphasis=75 μ s	40	50		dB
α_{38}	Subcarrier	f=38kHz, Deemphasis=75 μ s		75		dB
α_{57}	Subcarrier	f=57kHz, Deemphasis=75 μ s		62		dB
α_{76}	Subcarrier	f=76kHz, Deemphasis=75 μ s		90		dB
Intermodulation						
α_2	f _{mod} =10kHz, f _{spur} =1kHz			65		dB
α_3	f _{mod} =13kHz, f _{spur} =1kHz			75		dB
Traffic Radio						
α_{57}	Signal	f = 57kHz		70		dB
SCA – Subsidiary Communication Authorization						
α_{67}	Signal	f = 67kHz		75		dB
ACI – Adjacent Channel Interference						
α_{114}	Signal	f = 114kHz		95		dB
α_{190}	Signal	f = 190kHz		84		dB

3.4.1 NOTES TO THE CHARACTERISTICS

3.4.1.1 Intermodulation Suppression

$$\alpha_2 = \frac{V_O(\text{signal})(\text{at}1\text{kHz})}{V_O(\text{spurious})(\text{at}1\text{kHz})}; \quad f_s = (2 \cdot 10\text{kHz}) - 19\text{kHz}$$

$$\alpha_3 = \frac{V_O(\text{signal})(\text{at}1\text{kHz})}{V_O(\text{spurious})(\text{at}1\text{kHz})}; \quad f_s = (3.13 \cdot \text{kHz}) - 38\text{kHz}$$

measured with: 91% pilot signal; $f_m = 10\text{kHz}$ or 13kHz .

3.4.1.2 Traffic Radio (V.F.) Suppression

$$\alpha_{57}(\text{VWF}) = \frac{V_O(\text{signal})(\text{at}1\text{kHz})}{V_O(\text{spurious})(\text{at}1\text{kHz} \pm 23\text{kHz})}''''$$

www.DataSheet4U.com

measured with: 91% stereo signal; 9% pilot signal; $f_m=1\text{kHz}$; 5% subcarrier ($f=57\text{kHz}$, $f_m=23\text{Hz}$ AM, $m=60\%$)

3.4.1.3 SCA (Subsidiary Communications Authorization)

$$\alpha_{67} = \frac{V_O(\text{signal})(\text{at}1\text{kHz})}{V_O(\text{spurious})(\text{at}1\text{kHz})}; \quad f_s = (2.38\text{kHz}) - 67\text{kHz}$$

measured with: 81% mono signal; 9% pilot signal; $f_m=1\text{kHz}$; 10%SCA - subcarrier ($f_s = 67\text{kHz}$, unmodulated).

3.4.1.4 ACI (Adjacent Channel Interference)

$$\alpha_{114} = \frac{V_O(\text{signal})(\text{at}1\text{kHz})}{V_O(\text{spurious})(\text{at}1\text{kHz})}; \quad f_s = 110\text{kHz} - (3.38\text{kHz})$$

$$\alpha_{190} = \frac{V_O(\text{signal})(\text{at}1\text{kHz})}{V_O(\text{spurious})(\text{at}1\text{kHz})}; \quad f_s = 186\text{kHz} - (5.38\text{kHz})$$

measured with: 90% mono signal; 9% pilot signal; $f_m=1\text{kHz}$; 1% spurious signal ($f_s = 110\text{kHz}$ or 186kHz , unmodulated).

3.5 Noise Blanker

Table 7.

Symbol	Parameter	Test Condition	Min.	Typ.	Max.	Unit	
V _{TR}	BLTHL=PEAK+VBE+V _{PROG}						
	Trigger Threshold 1) meas.with V _{PEAK} =0.9V, InGain=5.75dB	111			30		mV _{OP}
		110			35		mV _{OP}
		101			40		mV _{OP}
		100			45		mV _{OP}
		011			50		mV _{OP}
		010			55		mV _{OP}
		001			60		mV _{OP}
000			65		mV _{OP}		
V _{TRNOISE}	BLTHH=PEAK+VBE+m*(PEAK-1.5V)+m*0.56V						
	noise controlled Trigger Threshold meas.with V _{PEAK} =1.5V, InGain=5.75dB	00			260		mV _{OP}
		01			220		mV _{OP}
		10			180		mV _{OP}
		11			140		mV _{OP}
V _{RECT}	Rectifier Voltage with InGain=5.75dB	VMPX=0mV	0.5	0.9	1.3	V	
		VMPX=50mV, f=150kHz	1.5	1.7	2.1	V	
		VMPX=200mV, f=150kHz	2	2.5	2.9	V	
V _{RECTDEV}	Deviation dependent Rectifier Voltage with VMPX=500mV _{rms} & InGain=5.75dB	11		0.9(off)		V _{OP}	
		10		1.1		V _{OP}	
		01		1.8		V _{OP}	
		00		2.6		V _{OP}	
V _{RECTFS}	Fieldstrength controlled Rectifier Voltage meas.with VMPX=0mV, V _{LEVEL} << V _{SBL} (fully mono)	11		0.9(off)		V	
		10		1.1		V	
		01		1.5		V	
		00		2.8		V	
T _{SFM}	Suppression Pulse Duration FM Signal HOLDN in Testmode	00		38		μs	
		01		25.5		μs	
		10		32		μs	
		11		22		μs	
V _{RECTADJ}	Noise rectifier discharge (2) adjustment Signal PEAK in Testmode	00		inf.		W	
		01		56		MΩ	
		10		33		MΩ	
		11		18		MΩ	
S _{RPEAK}	Noise rectifier (2) charge Signal PEAK in Testmode	0		10		mV/μs	
		1		20		mV/μs	

Table 7. (continued)

Symbol	Parameter	Test Condition	Min.	Typ.	Max.	Unit
V _{ADJMP}	Noise rectifier adjustment through Multipath (2) Signal PEAK in Testmode	00		0.3		V/ms
		01		0.5		V/ms
		10		0.7		V/ms
		11		0.9		V/ms
AM Noise Blanker						
T _D	AM delay time			128		μs
f _c	Corner frequency of AM delay filter			4		kHz
AM config	AM configuration	Old mode (signal dependant threshold)	Noise dependent threshold			
		New mode (fixed threshold), STDInGain must be 0.5dB		140		%
f _{CHP}	AM Noise Detector High Pass Frequency	0		10		kHz
		1		20		kHz
	AM Noise Detector High Pass Filter Order	0		1 st order		
		1		2 nd order		
TSAM	Suppression Pulse Duration AM Signal HOLDN in Testmode	00		1.2		ms
		01		800		μs
		10		1.0		ms
		11		640		μs

Notes:

1. All thresholds are measured using a pulse with TR = 2 μs, THIGH= 2 μs and TF = 10 μs. The repetition rate must not increase the PEAK voltage.
2. By design/characterization functionally guaranteed through dedicated test mode structure

Table 8. Quality Actuators

Symbol	Parameter	Test Condition	Min.	Typ.	Max.	Unit
Stereo Blend						
V _{sbST}	V _{sb} control voltage for full stereo			5		V
V _{SBL}	VSBL = 2V + ("d" factor) * 3V	see below				
d	VSB Control Voltage for Full Mono d factor	000		29		%
		001		33		%
		010		38		%
		011		42		%
		100		46		%
		101		50		%
		110		54		%
		111		58		%

Table 8. Quality Actuators (continued)

Symbol	Parameter	Test Condition	Min.	Typ.	Max.	Unit
	Blend Adjustment	The filtered Smeter input to the SNC detector has variable gain and offset. See SNC Detector specs.				
High Cut Control						
VHCH	$VHCH = a * b * 4V$ (level = Smeter * 1.0)	see below				
a	VHCH Shift "a" factor	0001		97		%
		0010		73		%
		0100		50		%
		1000		32		%
b	VHCH "b" factor	00		67		%
		01		75		%
		10		83		%
		11		92		%
VHCL	VHC Control Voltage for FULL Highcut Rolloff	for HCC control from level (where level = Smeter * 1.0): $VHCL = a * b * c * 4V$ (or $VHCL = c * VHCH$)				
		for HCC control from SNC: $VHCL = 2V + a * b * c * 3V$				
c	VHCL "c" factor	00		16.70		%
		01		22.20		%
		10		27.80		%
		11		33.30		%
fc range	HCC Filter cutoff frequency range	00		20kHz ~ 4kHz		
		01		10kHz ~ 2kHz		
		10		4kHz ~ 800Hz		
		11		4kHz ~ 800Hz		
HCC step	Number of settings (per range)			32		

Table 8. Quality Actuators (continued)

Symbol	Parameter	Test Condition	Min.	Typ.	Max.	Unit	
ATT _{MAX/MIN}	The maximum high cut attenuation can be selected via I ² C [addr 8C, subaddr 23d, bits D2 to D1]. NOTES: - The maximum high cut frequency setting can make the maximum attenuation lower than this. But then you effectively have a fixed rolloff filter, because the max high cut frequency will keep the hcc filter frequency from moving any higher, and the max high cut attenuation will keep the hcc filter frequency from moving any lower. - Also, there is an alternative way of setting the maximum high cut attenuation, but only if a maximum high cut frequency does not need to be selected. The FAST3 can be set to limit the minimum high cut frequency [addr 8C, subaddr 25d, bit D6], then any of the 32 high cut frequencies can be selected to limit the max attenuation.						
	Max/Min high Cut Attenuation(at 10kHz)@ HCC range 20kHz~4kHz	00			-1.8		dB
		01			-4.4		dB
		10			-6.2		dB
		11			-7.0		dB
	Max/Min high Cut Attenuation(at 10kHz)@ HCC range 10kHz~2kHz	00			-5.6		dB
		01			-9.3		dB
		10			-11.5		dB
		11			-12.4		dB
	Fixed Rolloff	There are two ways to set the HCC filter to a fixed filter (there will be no dynamic movement of the filter). Both of these will set the filter to the corner frequency selected in the Max/Min High Cut Frequency [addr 8C, subaddr 25d, bits D4 to D0]. 1) Set the FAST3 to Fixed High Cut ON [addr 8C, subaddr 25d, bit D7]. 2) Turn High Cut OFF [addr 8C, subaddress 23, bit D0] and Fix Maximum High Cut Frequency [addr 8C, subaddr 25d, bit D6]					

3.6 AUDIO PROCESSOR

($V_S = 8.5V$; $T_{amb} = 25^\circ C$; $R_L = 10k\Omega$; all gains = 0dB; $f = 1kHz$; unless otherwise specified)

Table 9.

Symbol	Parameter	Test Condition	Min.	Typ.	Max.	Unit
INPUT SELECTOR						
R_{in}	Input Resistance	All single ended inputs	70	100	130	$k\Omega$
V_{CL}	Clipping level			2		V_{RMS}
S_{IN}	Input Separation		80	100		dB
$G_{IN\ MIN}$	Min. Input Gain		-1	0	+1	dB
$G_{IN\ MAX}$	Max. Input Gain		13	15	17	dB
G_{STEP}	Step Resolution		0.5	1	1.5	dB
V_{DC}	DC Steps	Adjacent Gain Steps	-5	1	5	mV
		G_{MIN} to G_{MAX}	-10	6	10	mV
V_{offset}	Remaining offset with AutoZero			0.5		mV
QUASI DIFFERENTIAL STEREO INPUT						
R_{in}	Input Resistance	all inputs to ground	70	100	130	$k\Omega$
G_{QD}	Gain			-4		dB
Symbol	Parameter	Test Condition	Min.	Typ.	Max.	Unit
CMRR	Common Mode Rejection Ratio	$V_{CM}=1\ V_{RMS}@ 1kHz$	46	70		dB
		$V_{CM}=1\ V_{RMS}@ 10kHz$	46	60		dB
e_{NO}	Output Noise @ Speaker Outputs	20Hz-20kHz,flat; all stages 0dB		20		μV
SINGLE-ENDED STEREO INPUT						
R_{in}	Input Resistance		70	100	130	$k\Omega$
G_{QD}	Gain			0		dB
e_{NO}	Output Noise @ Speaker Outputs	20Hz-20kHz,flat; all stages 0dB		TBD		μV
DIFFERENTIAL MONO INPUT						
R_{in}	Input Resistance	Differential	40	56	72	$k\Omega$
G_{MD}	Gain			-4		dB
CMRR	Common Mode Rejection Ratio	$V_{CM}=1\ V_{RMS}@ 1kHz$	40	70		dB
		$V_{CM}=1\ V_{RMS}@ 10kHz$	40	60		dB
e_{NO}	Output Noise @ Speaker Outputs	20Hz-20kHz,flat; all stages 0dB		TBD		μV
BEEP CONTROL						
V_{RMS}	Beep Level	all flat		TBD		mV
f_{Beep}	Beep Frequency	f_{Beep1}		500		Hz
		f_{Beep2}		1		kHz
		f_{Beep1}		2		kHz
		f_{Beep2}		3		kHz

Table 9. (continued)

LOUDNESS CONTROL						
Symbol	Parameter	Test Condition	Min.	Typ.	Max.	Unit
A_{MAX}	Max Attenuation		-21	-19	-17	dB
A_{STEP}	Step Resolution		0.5	1	1.5	dB
$f_{PeakLPF}$	LPF Peak Frequency	f_{P1}		32.5		Hz
		f_{P2}		40		Hz
		f_{P3}		150		Hz
$f_{PeakHPF}$	HPF Peak Frequency	f_{P1}		4		kHz
		f_{P2}		6		kHz
		f_{P3}		8		kHz
		f_{P4}		10		kHz
VOLUME CONTROL						
G_{MAX}	Max Gain		14	15	16	dB
A_{MAX}	Max Attenuation		-83	-79	-75	dB
A_{STEP}	Step Resolution		0.5	1	1.5	dB
E_A	Attenuation Set Error	$G = -20$ to $+15$ dB			2	dB
		$G = -79$ to -20 dB			4	dB
E_T	Tracking Error				2	dB
V_{DC}	DC Steps	Adjacent Attenuation Steps		0.1	3	mV
		From 0dB to G_{MIN}		0.5	5	mV
SOFT MUTE						
A_{MUTE}	Mute Attenuation		80			dB
T_D	Delay Time	T_1		0.48		ms
		T_2		0.96		ms
		T_3		20.2		ms
		T_4		40.4		ms
$V_{TH\ Low}$	Low Threshold for SM Pin				1	V
$V_{TH\ High}$	High Threshold for SM Pin		2.5			V
BASS CONTROL						
C_{RANGE}	Control Range		± 14	± 15	± 16	dB
A_{STEP}	Step Resolution		0.5	1	1.5	dB
f_c	Center Frequency	f_{C1}	54	60	66	Hz
		f_{C2}	72	80	88	Hz
		f_{C3}	90	100	110	Hz
		f_{C4}	117	130	143	Hz
Q_{BASS}	Quality Factor	Q_1	0.9	1	1.1	
		Q_2	1.1	1.25	1.4	
		Q_3	1.3	1.5	1.7	

Table 9. (continued)

Symbol	Parameter	Test Condition	Min.	Typ.	Max.	Unit
		Q ₄	1.8	2	2.2	
DC _{GAIN}	Bass-DC-Gain	DC = off	-1	0	+1	dB
		DC = on (shelving filter) @ gain = ±15 dB		±10		dB
TREBLE CONTROL						
C _{RANGE}	Clipping Level		±14	±15	±16	dB
A _{STEP}	Step Resolution		0.5	1	1.5	dB
f _c	Center Frequency	f _{c1}	8	10	12	kHz
		f _{c2}	10	12.5	15	kHz
		f _{c3}	12	15	18	kHz
		f _{c4}	14	17.5	21	kHz
SPEAKER ATTENUATORS						
R _{in}	Input Impedance		35	50	65	kΩ
G _{MAX}	Max Gain		14	15	16	dB
A _{MAX}	Max Attenuation		-83	-79	-75	dB
A _{STEP}	Step Resolution		0.5	1	1.5	dB
A _{MUTE}	Mute Attenuation		80	90		dB
E _E	Attenuation Set Error				2	dB
V _{DC}	DC Steps	Adjacent Attenuation Steps		0.1	5	mV
CHIME INPUT						
G	Gain to speaker outputs			-19		dB
AUDIO OUTPUTS						
V _{CL}	Clipping level	d = 0.3%	1.8	2		V _{RMS}
R _{OUT}	Output impedance			30	100	W
R _L	Output Load Resistance		2			kΩ
C _L	Output Load Capacitor				10	nF
V _{AC}	AC gain			4		dB
V _{DC}	DC Voltage Level		3.8	4.0	4.2	V
GENERAL						
e _{NO}	Output Noise	BW=20Hz to 20 kHz all gain = 0dB		20		μV
S/N	Signal to Noise Ratio	all gain = 0dB flat; V _o =2V _{RMS}		100		dB
d	Distortion	V _{IN} =1V _{RMS} ; all stages 0dB		0.005	0.1	%
Sc	Channel Separation Left/Right		80	100		dB

4 I²C-BUS INTERFACE

The TDA7514 supports the I²C-Bus protocol. This protocol defines any device that sends data onto the bus as a transmitter, and the receiving device as the receiver. The device that controls the transfer is a master and device being controlled is the slave. The master will always initiate data transfer and provide the clock to transmit or receive operations. The TDA7514 is always a slave.

4.1 Data Transition

Data transition on the SDA line must only occur when the clock SCL is LOW. SDA transitions while SCL is HIGH will be interpreted as START or STOP condition.

4.2 Start Condition

A start condition is defined by a HIGH to LOW transition of the SDA line while SCL is at a stable HIGH level. This "START" condition must precede any command and initiate a data transfer onto the bus. The device continuously monitors the SDA and SCL lines for a valid START and will not response to any command if this condition has not been met.

4.3 Stop Condition

A STOP condition is defined by a LOW to HIGH transition of the SDA while the SCL line is at a stable HIGH level. This condition terminates the communication between the devices and forces the bus interface of the device into the initial condition.

4.4 Acknowledge

Indicates a successful data transfer. The transmitter will release the bus after sending 8 bits of data. During the 9th clock cycle the receiver will pull the SDA line to LOW level to indicate it receive the eight bits of data.

4.5 Data Transfer

During data transfer the device samples the SDA line on the leading edge of the SCL clock. Therefore, for proper device operation the SDA line must be stable during the SCL LOW to HIGH transition.

4.6 Device Addressing

To start the communication between two devices, the bus master must initiate a start instruction sequence, followed by an eight bit word corresponding to the address of the device it is addressing.

The TDA7514 addresses are: C4 HEX (Section 1 write), C5 HEX (Section 1 read), 8C HEX (Section 2 write), 8D HEX (section 2 read).

The TDA7514 connected to the bus will compare its own hardwired addresses with the slave address being transmitted, after detecting a START condition.

After this comparison, the TDA7514 will generate an "acknowledge" on the SDA line and will do either a read or a write operation according to the state of R/W bit.

4.7 Write Operation

Following a START condition the master sends a slave address word with the R/W bit set to "0". The device will generate an "acknowledge" after this first transmission and will wait for a second word (the sub-address field).

This 8-bit subaddress field provides an access to any of internal registers. Upon receipt of the word address the TDA7514 slave device will respond with an "acknowledge". At this time, all the following words transmitted will be considered as Data. The internal subaddress can be automatically incremented, according to the status of the "Page Mode" bit (Subaddress byte S5).

4.8 Read Operation

If the master sends a slave address word with the R/W bit set to 1, the TDA7514 will transmit one 8-bit data word (see the relevant tables in "Register Organization" section).

Figure 3. Frame example

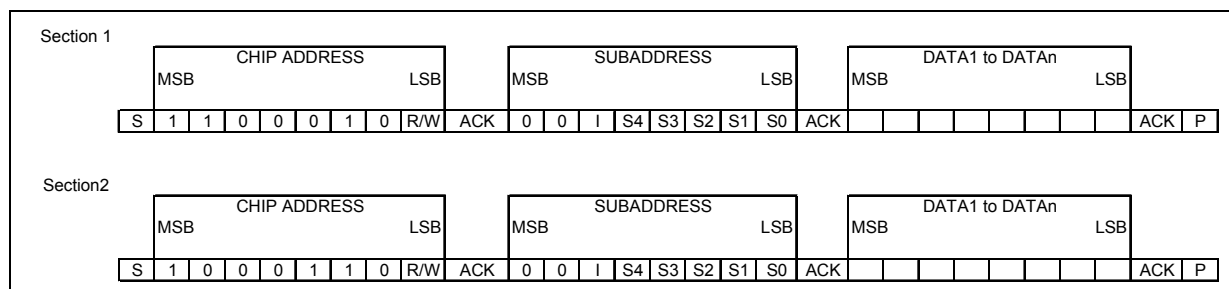

S = START

P = STOP

ACK = Acknowledge

I = Page Mode

Figure 4. Timing Diagram and Electrical Characteristics

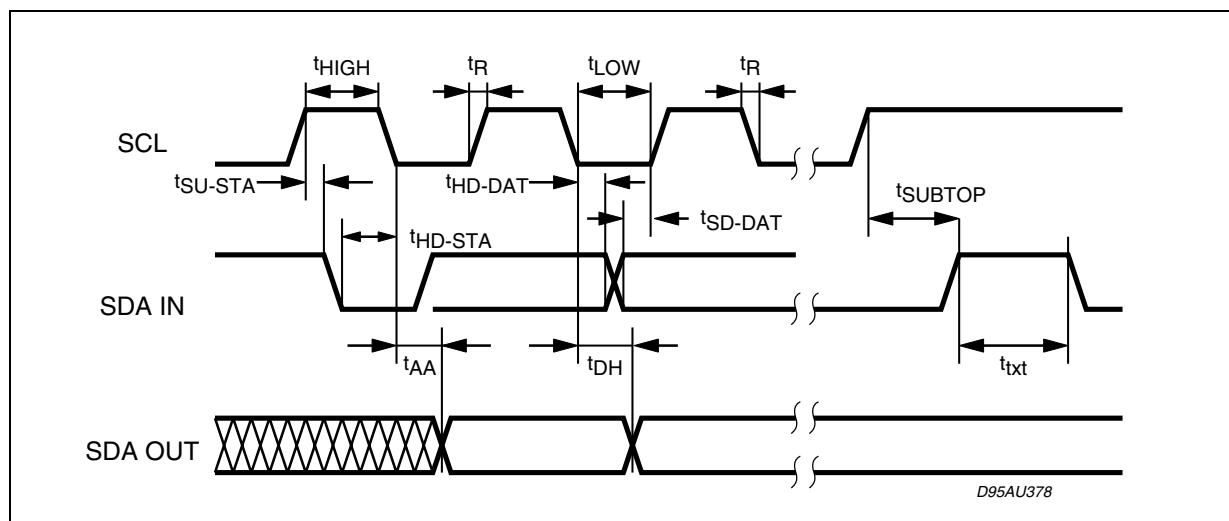

Table 10.

Symbol	Parameter	Test Condition	Min	Typ	Max	Unit
f _{SCL}	SCL Clock Frequency			100	500	kHz
t _{AA}	SCL Low to SDA Data Valid			300		ns
t _{out}	Time the Bus must be free for the New Transmission			4.7		μs
t _{HD-STA}	Start Condition Host Time			4.0		μs
t _{LOW}	Clock Low Period			4.7		μs
t _{HIGH}	Clock High period			4.0		μs
t _{SU-SDA}	Start Conditions Setup Time			4.7		μs
t _{HD-DAT}	Data Input Hold Time			0		μs
t _{SU-DAT}	Data Input setup Time			4.7		μs
t _{SU-DAT}	Data Input Setup Time			250		ns
t _R	SDA & SCL Rise Time			250		μs
t _F	SDA & SCL Full Time					μs
t _{SU-STO}	Stop Condition Setup Time			4.7		μs
t _{DH}	Data Out Time			300		ns
V _{IL}	Input Low Voltage				1	V
V _{IH}	Input High Voltage		3			V

4.9 Register Organization

Table 11. Section 1 (Turner)ADDRESS

MSB							LSB
D7	D6	D5	D4	D3	D2	D1	D0
1	1	0	0	0	1	0	R/W

Table 12. SUBADDRESS

MSB							LSB
S7	S6	S5	S4	S3	S2	S1	S0
X	X	autoincr	subaddress				

Table 13. READ MODE: ISS OUTPUTS)

MSB							LSB
S7	S6	S5	S4	S3	S2	S1	S0
DEV+	DEV	AC	FS	SSTOP	MP	BW	ON

Table 14. Address Organization (Tuner Section)

	MSB							LSB	Function
Subaddr.	D7	D6	D5	D4	D3	D2	D1	D0	
0	STBY	Current select	Low current		High current				Charge Pump Control and STBY
1	Lock detenable	activation delay		Phase difference threshold		AM/FM	fref BYPASS	VCOadj clockenab	PLL Lock Detector, FM mode and tests
2	counter LSB								PLL Counter 1 (LSB)
3	counter MSB								PLL Counter 2 (MSB)
4	counter LSB								PLL Reference Counter 2 (LSB)
5	counter MSB								PLL Reference Counter 2 (MSB)
6	FM FE slope adjust								FM FE slope adjust
7	FM VCO div			AM WAGC starting point					AM WAGC starting point, FM VCO divider
8	SetBP/HPII biquad	Set BP/ HPI biquad	Set f _c II biquad	Set f _c I biquad	FC enable	Δf			Quad adjch filter programming, IF Counter Control1
9	t _{SAMPLE}			t _{CENTER}					IF Counter Control 2 (central frequency and sampling time)
10	counter LSB								IF Counter Reference (LSB)
11	IFC AM/FM		counter MSB						IF Counter Reference (MSB) and IF Counter Mode Select
12	AMVCO div		SoftMute to FM deviation	AM NAGC threshold					AM NAGC threshold, AM VCO divider
13	Not used	WB gain	UNAGC threshold				NAGC off	Fast AGC on	AM fast AGC1, AM NAGC OGFF, AM UNAGC, WB audio gain
14	AdiCh full mute level		FSmeter full mute level			AdjCh mute thr	Soft mute thr		Soft Mute, adjacent channel mute
15	Qual. MultiPath detector rectifier gain			FSmeter Offset	FSmeter Gain				Quality Detection: FSmetr offset and gain (SNC), Multipath detector rectifier gain
16	ISSfilter test		Smetr 10ms/1s	Quality AFcheck	Quality fast test	HCC source	Qual adjacent channel dtctor rect. gain		Quality Detection: AdjCh detector gain and offset, HCC source, Quality fast test mode, AF check mode: ISS filter test
17	ISS test connect	Smet test connect	ISS center frequency		FMIFAMP2 gain		FMIFAMP1 gain		FM IFAMP gains, ISScenter frequency, Smetr/ISS test connections
18	Set Gain in AdjCh II biquad	Enable seek mode	Quad AdjCh Rectifier offset		VCO adj start	PLL test MUXer			Qual AdjCh detector gain, seek mode, Qual AdjCh Rectifier offset, PLL test MUXer, 456KHz VCO adjustment start
19	Manual/ ENIFC	manual SET 456	Manual VCO frequency					manual/ auto	456KHz VCO adjustment (manual mode)
20	iSS Smetr threshold				FM Smetr Stop threshold				FM Smetr stop threshold, ISS Smetr Threshold
21	Smetr test MUXer						Sd pin configuration		Smetr test MUXer, SD pin configuration
22	SEEK	ISS AC desens slope		ISS AC desens threshold		ISS AC filter mode			Seek, ISS adjacent channel detector
23	FM KAGC enable	FM NAGC thr MSB	FM mix gain adj		FM mix phase adj				Fm mixer1 adjust, FM AGC

Table 14. Address Organization (Tuner Section) (continued)

Subaddr.	MSB							LSB	Function
	D7	D6	D5	D4	D3	D2	D1	D0	
24	not used		Ciksep	XTAL adjustment					XTAL adjustment, clock sep
25	QualityOut AC gain		QualityOut MP gain		ISS MP rectifier gain		ISS/Quality MP filtergain	Multipath detector, Quality out	
26	FMNAGC threshold LSD		FMWAGC threshold			FM demod ref frequency divider		FMdemod ref frequency divider, FM AGC	
27	not used	FM demod NB		FM demod fine adjust				FM demod fine adjust, FM demod noise blanker	
28	Test disable connect	EXT WB enable	Smeter Slider					Smeter sloder, External WB, testing	
29	AMIF 2AMP gain				AM Smeter Stop threshold			AM stop station, AM IF 2 Amplifier Gain	
			FM demod input						
30	not used	AM FAST AGC2	ARS ISS indicator	WX narrow Sm &	IFT1 adjust			IFT adjust, AM fast AGC2, ARS, WB narrow Smeter/FC	
31	not used		AMIFNB Smeter dis threshold		AMIFNB slow rect offset			AM IF NB	

Table 15. SUBADDRESS 0: Change Pump Control

MSB				LSB				FUNCTION
D7	D6	D5	D4	D3	D2	D1	D0	
				0	0	0	0	High current = 0mA
				0	0	0	1	High current = 0.5mA
				0	0	1	0	High current = 1 mA
				0	0	1	1	High current = 1.5mA
				1	1	1	1	High current = 7.5mA
		0	0					Low current = 0µA
		0	1					Low current = 50µA
		1	0					Low current = 100µA
		1	1					Low current = 150µA
								Change cump current control
	0							low current only
	1							Automatic current control
								Turner Stand-by
0								Turner StandBy OFF
1								Turner StandBy ON

Table 16. SUBADDRESS 1: PLL Lock detector, FM mode and test

MSB							LSB		FUNCTION
D7	D6	D5	D4	D3	D2	D1	D0		
Charge Pump									
							0	VCO adjust lock Disable	
							1	VCO adjust lock Enable	
						0		fref BYPASS Disable	
						1		fref BYPASS Enable	
Turner/pll Am/fm Mode									
					0			Select AM mode	
					1			Select FM mode	
Lock Detector Control									
			0	0				PD phase difference threshold 10ns	
			0	1				PD phase difference threshold 20ns	
			1	0				PD phase difference threshold 30ns	
			1	1				PD phase difference threshold 40ns	
	0	0						Not valid	
	0	1						Activation delay 4x1/f _{REF}	
	1	0						Activation delay 6x1/f _{REF}	
	1	1						Activation delay 8x1/f _{REF}	
Lock Detector On/Off									
0								Lock detector doesn't control charge pump	
1								Lock detector controls charge pump	

Table 17. SUBADDRESS 2: PLL Counter 1 (LSB)

MSB							LSB		FUNCTION
D7	D6	D5	D4	D3	D2	D1	D0		
0	0	0	0	0	0	0	0	LSB = 0	
0	0	0	0	0	0	0	1	LSB = 1	
0	0	0	0	0	0	1	0	LSB = 2	
-	-	-	-	-	-	-	-	-	
1	1	1	1	1	1	0	0	LSB = 252	
1	1	1	1	1	1	0	1	LSB = 253	
1	1	1	1	1	1	1	0	LSB = 254	
1	1	1	1	1	1	1	1	LSB = 255	

Table 18. SUBADDRESS 3: PLL Counter 2 (MSB)

MSB							LSB		FUNCTION
D7	D6	D5	D4	D3	D2	D1	D0		
0	0	0	0	0	0	0	0	MSB = 0	
0	0	0	0	0	0	0	1	MSB = 256	
0	0	0	0	0	0	1	0	MSB = 512	
-	-	-	-	-	-	-	-	-	
1	1	1	1	1	1	0	0	MSB = 64768	
1	1	1	1	1	1	0	1	MSB = 65024	
1	1	1	1	1	1	1	0	MSB = 65280	
1	1	1	1	1	1	1	1	MSB = 65536	

Note: 1 Swallow mode: $f_{VCO}/f_{SYN} = LSB + MSB + 32$

Table 19. SUBADDRESS 4: PLL Reference Counter 1 (LSB)

MSB							LSB		FUNCTION
D7	D6	D5	D4	D3	D2	D1	D0		
0	0	0	0	0	0	0	0	LSB = 0	
0	0	0	0	0	0	0	1	LSB = 1	
0	0	0	0	0	0	1	0	LSB = 2	
-	-	-	-	-	-	-	-	-	
1	1	1	1	1	1	0	0	LSB = 252	
1	1	1	1	1	1	0	1	LSB = 253	
1	1	1	1	1	1	1	0	LSB = 254	
1	1	1	1	1	1	1	1	LSB = 255	

Table 20. SUBADDRESS 5: PLL Reference Counter 2 (MSB)

MSB							LSB		FUNCTION
D7	D6	D5	D4	D3	D2	D1	D0		
0	0	0	0	0	0	0	0	MSB = 0	
0	0	0	0	0	0	0	1	MSB = 256	
0	0	0	0	0	0	1	0	MSB = 512	
-	-	-	-	-	-	-	-	-	
1	1	1	1	1	1	0	0	MSB = 64768	
1	1	1	1	1	1	0	1	MSB = 65024	
1	1	1	1	1	1	1	0	MSB = 65280	
1	1	1	1	1	1	1	1	MSB = 65536	

Note: $1 f_{VCO}/f_{SYN} = LSB + MSB + 1$

Table 21. SUBADDRESS 6: FM FE Adjustment Slope

MSB							LSB		FUNCTION
D7	D6	D5	D4	D3	D2	D1	D0		
0	0	0	0	0	0	0	0	$\alpha = 0$ (-100%)	
0	0	0	0	0	0	0	1	$\alpha = 1$	
-	-	-	-	-	-	-	-	-	
1	1	1	1	1	1	1	1	$\alpha = 255$ (+99%)	

Adjusted voltage:
without diode connected: $V_{out} = (\alpha / 128) V_t$

Table 22. SUBADDRESS 7: AM WAGC Starting point, FM VCO divider

MSB								LSB		FUNCTION	
D7	D6	D5	D4	D3	D2	D1	D0				
								AM Wide AGC Threshold			
								@AMMIX1in	@SG		
			0	0	0	0	0	88.0	88.0		
			0	0	0	0	1	90.7	90.7		
			0	0	0	1	0	92.7	92.7		
			0	0	0	1	1	94.4	94.4		
			0	0	1	0	0	95.5	95.5		
			0	0	1	0	1	96.6	96.6		
			0	0	1	1	0	97.6	97.6		
			0	0	1	1	1	98.4	98.4		
			0	1	0	0	0	99.2	99.2		
			0	1	0	0	1	99.9	99.9		
			0	1	0	1	0	100.6	100.6		
			0	1	0	1	1	101.2	101.2		
			0	1	1	0	0	101.7	101.7		
			0	1	1	0	1	102.2	102.2		
			0	1	1	1	0	102.7	102.7		
			0	1	1	1	1	103.1	103.1		
			1	0	0	0	0	103.6	103.6		
			1	0	0	0	1	104.0	104.0		
			1	0	0	1	0	104.4	104.4		
			1	0	0	1	1	104.8	104.8		
			1	0	1	0	0	105.1	105.1		
			1	0	1	0	1	105.5	105.5		
			1	0	1	1	0	105.8	105.8		
			1	0	1	1	1	106.1	106.1		
			1	1	0	0	0	106.4	106.4		
			1	1	0	0	1	106.7	106.7		
			1	1	0	1	1	106.9	106.9		
			1	1	0	1	0	107.2	107.2		
			1	1	1	0	0	107.5	107.5		
			1	1	1	0	1	107.7	107.7		
			1	1	1	1	0	107.9	107.9		
			1	1	1	1	1	108.1	108.1		
								FM VCO divider control			
	0	0						all off			
	0	1						divide by 2			
	1	0						divide by 3			
	1	1						divide by 3			
0								phase (I) = $-90^\circ \geq$ high side conversion			
1								phase (I) = $+90^\circ \geq$ low side conversion			

Table 23. SUBADDRESS 8 : IF Counter Control 1 and AM S.S. Threshold

MSB				LSB				FUNCTION
D7	D6	D5	D4	D3	D2	D1	D0	
								IF Counter frequency window
					0	0	0	Not valid
					0	0	1	Not valid
					0	1	0	Not valid
					0	1	1	$\Delta f = 6.25\text{kHz}$ (FM) 1kHz (AM UPC)
					1	0	0	$\Delta f = 12.5\text{kHz}$ (FM) 2kHz (AM UPC)
					1	0	1	$\Delta f = 25\text{kHz}$ (FM) 4kHz (AM UPC)
					1	1	0	$\Delta f = 50\text{kHz}$ (FM) 8kHz (AM UPC)
					1	1	1	$\Delta f = 100\text{kHz}$ (FM) 16kHz (AM UPC)
								IF counter on/off
				0				IF counter disable/stand by
				1				IF counter enable
								Adjacent Channel programming
			0					Filter 1F _c = 80kHz
			1					Filter 1F _c = 100kHz
		0		-	-	-	-	Filter 2F _c = 110kHz
		1						Filter 2F _c = 140kHz
	0			-	-	-	-	Filter 1HP
	1							Filter 1BP
0				-	-	-	-	Filter 2HP
1								Filter 2BP

Table 24. SUBADDRESS 9: If Counter Control 2

MSB				LSB				FUNCTION
D7	D6	D5	D4	D3	D2	D1	D0	
								FM antenna adj (proportional to Vtuning)
			0	0	0	0	0	$f_{\text{center}} = 10.60625\text{MHz}$ (FM) 449KHz (AM)
			0	0	0	0	1	$f_{\text{center}} = 10.61250\text{MHz}$ (FM) 449KHz (AM)
-	-	-	-	-	-	-	-	-
			0	1	0	1	0	$f_{\text{center}} = 10.66875\text{MHz}$ (FM) 458KHz (AM)
			0	1	0	1	1	$f_{\text{center}} = 10.67500\text{MHz}$ (FM) 459KHz (AM)
			0	1	1	0	0	$f_{\text{center}} = 10.68125\text{MHz}$ (FM) 460KHz (AM)
			0	1	1	0	1	$f_{\text{center}} = 10.68750\text{MHz}$ (FM) 461KHz (AM)
			0	1	1	1	0	$f_{\text{center}} = 10.69375\text{MHz}$ (FM) 462KHz (AM)
			0	1	1	1	1	$f_{\text{center}} = 10.70000\text{MHz}$ (FM) 463KHz (AM)
			1	0	0	0	0	$f_{\text{center}} = 10.70625\text{MHz}$ (FM) 464KHz (AM)
			1	0	0	0	1	$f_{\text{center}} = 10.71250\text{MHz}$ (FM) 465KHz (AM)
-	-	-	-	-	-	-	-	-
			1	1	1	1	1	$f_{\text{center}} = 10.80000\text{MHz}$ (FM) 479KHz (AM)
								IF counter time windiw
0	0	0						$t_{\text{sample}} = 20.48\text{ms}$ (FM) 128ms (AM)
0	0	1						$t_{\text{sample}} = 10.24\text{ms}$ (FM) 64ms (AM)
0	1	0						$t_{\text{sample}} = 5.12\text{ms}$ (FM) 32ms (AM)
0	1	1						$t_{\text{sample}} = 2.568\text{ms}$ (FM) 16ms (AM)
1	0	0						$t_{\text{sample}} = 1.28\text{ms}$ (FM) 8ms (AM)
1	0	1						$t_{\text{sample}} = 640\mu\text{s}$ (FM) 4ms (AM)
1	1	0						$t_{\text{sample}} = 320\mu\text{s}$ (FM) 2ms (AM)
1	1	1						$t_{\text{sample}} = 160\mu\text{s}$ (FM) 1ms (AM)

Table 25. SUBADDRESS 10: IF Counter Reference (LSB)

MSB							LSB		FUNCTION
D7	D6	D5	D4	D3	D2	D1	D0		
0	0	0	0	0	0	0	0	LSB = 0	
0	0	0	0	0	0	0	1	LSB = 1	
0	0	0	0	0	0	1	0	LSB = 2	
-	-	-	-	-	-	-	-	-	
1	1	1	1	1	1	0	0	LSB = 252	
1	1	1	1	1	1	0	1	LSB = 253	
1	1	1	1	1	1	1	0	LSB = 254	
1	1	1	1	1	1	1	1	LSB = 255	

Table 26. SUBADDRESS 11: IF Counter Reference (MSB) and IF Counter Mode Select

MSB							LSB		FUNCTION
D7	D6	D5	D4	D3	D2	D1	D0		
		0	0	0	0	0	0	MSB = 0	
		0	0	0	0	0	1	MSB = 256	
		0	0	0	0	1	0	MSB = 512	
-	-	-	-	-	-	-	-	-	
		1	1	1	1	0	1	MSB = 15616	
		1	1	1	1	1	0	MSB = 15872	
		1	1	1	1	1	1	MSB = 16128	
								IF Counter Mode	
0	0							not valid	
0	1							IF counter FM mode (10.7KHz)	
1	0							IF counter AM mode (450KHz)	
0	0							not valid	

Note: $1 f_{osc}/f_{TIM} = LSB + MSB + 1$

Table 27. SUBADDRESS 12: AM NAGC , AM VCO Divider

MSB								LSB		FUNCTION	
D7	D6	D5	D4	D3	D2	D1	D0				
								AM Narrow band AGC Threshold			
								@AMMIX2in	@SG		
			0	0	0	0	0	79.9	77.9		
			0	0	0	0	1	82.4	80.4		
			0	0	0	1	0	84.2	82.2		
			0	0	0	1	1	85.7	83.7		
			0	0	1	0	0	86.5	84.5		
			0	0	1	0	1	87.7	85.7		
			0	0	1	1	0	88.6	86.6		
			0	0	1	1	1	89.5	87.5		
			0	1	0	0	0	90.1	88.1		
			0	1	0	0	1	91.0	89.0		
			0	1	0	1	0	91.6	89.6		
			0	1	0	1	1	92.1	90.1		
			0	1	1	0	0	92.6	90.6		
			0	1	1	0	1	93.1	91.1		
			0	1	1	1	0	93.6	91.6		
			0	1	1	1	1	94.0	92.0		
			1	0	0	0	0	94.5	92.5		
			1	0	0	0	1	94.8	92.8		
			1	0	0	1	0	95.2	93.2		
			1	0	0	1	1	95.5	93.5		
			1	0	1	0	0	96.0	94.0		
			1	0	1	0	1	96.2	94.2		
			1	0	1	1	0	96.9	94.9		
			1	0	1	1	1	97.2	95.2		
			1	1	0	0	0	97.5	95.5		
			1	1	0	0	1	98.0	96.0		
			1	1	0	1	1	98.5	96.5		
			1	1	0	1	0	98.8	96.8		
			1	1	1	0	0	99.1	97.1		
			1	1	1	0	1	99.4	97.4		
			1	1	1	1	0	99.7	97.7		
			1	1	1	1	1	100.0	98.0		
								FM Soft Mute to deviation threshold			
		0						50mV			
		1						150mV			
								AM VCO divider mode			
0	0							divide by 10			
0	1							divide by 8			
1	0							divide by 6			
1	1							divide by 4			

Table 28. SUBADDRESS 13: AM Fast AGC1, AM Ultra NARROW BAND AGC, Weather Band Gain

MSB							LSB	FUNCTION	
D7	D6	D5	D4	D3	D2	D1	D0		
							AM fast AGC1		
							0	off (R =100 Kohm)	
							1	on (R = 9 Kohm)	
							AM Narrow AGC disable		
							0	NAGC on	
							1	NAGC off	
							AM Ultra Narrow Band AGC Threshold		
								@ IF2AMPin	@ SG
								76	67
								86	77
								92	83
								90	81
								75	66
								85	76
								88	79
								78	69
								74	65
								83	74
								90	81
								79	70
								73	64
								82	73
								87	78
								77	68
							Weather Band audio gain boost		
							0	boost off (std audio gain)	
							1	boost on (audio gain x 15 = +23.5 dB)	

Table 29. SUBADDRESS 14: Soft Mute, Adjacent Channel Mute

MSB							LSB	FUNCTION		
D7	D6	D5	D4	D3	D2	D1	D0			
							Soft mute start/stop point (FM, AM) (*)			
							0	0	V _{SmeterL} =0,	V _{SmeterH} =0.6
							0	1	V _{SmeterL} =0.2,	V _{SmeterH} =0.6
							1	0	V _{SmeterL} =0.5,	V _{SmeterH} =1.4
							1	1	V _{SmeterL} =1.0,	V _{SmeterH} =1.4
							Adjacent channel mute start/stop point (FM)			
							0		V _{AdjChL} =1,	V _{AdjChH} =4.5
							1		V _{AdjChL} =2	V _{AdjChH} =4.5
							Full soft mute level			
									-4dB	
									(step = -2.5dB)	
									-21.5dB	
							Full adjacent channel mute level			
0	0							0dB		
0	1							-6dB		
1	0							-9dB		
1	1							-12dB		

(*) Cfr. byte 20 for dependency of ISS Smeter threshold on byte 14 programming

Table 30. SUBADDRESS 15: Quality detection: gain and offset on FSmeter (SNC), multipath detector rectifier gain

MSB							LSB	FUNCTION
D7	D6	D5	D4	D3	D2	D1	D0	
								FSmeter gain (SNC)
				0	0	0	0	0 dB
				-	-	-	-	(step = 0.15)
				1	1	1	1	2.25 dB
								FSmeter offset (SNC)
			0					1.8 V
			1					2.4 V
								Multipath detector rectifier gain
0	0	0						5 dB
-	-	-						(step = 1.2dB)
1	1	1						+13.4 dB

Table 31. SUBADDRESS 16: Quality Detection: Adjacent channel detector, HCC source, Quality fast test, Quality AF check, ISS filter test

MSB							LSB	FUNCTION
D7	D6	D5	D4	D3	D2	D1	D0	
								Qual adjacent channel detector rectifier gain
						0	0	12 dB
						0	1	17.3 dB
						1	0	18.4 dB
						1	1	20 dB
								High cut control source
					0			SNC
					1			FSmeter
								Quality filters fast test mode
				0				Test mode off
				1				Test mode on filt Smeter tau = 100 us SNC filt internal 22 pF
								Quality filters AF check freeze mode
			0					AF check off
			1					AF check on filt Smeter tau = 100 us 60ms/1s Smeter filt freeze MPath filt for StBlend freeze USN filt for StBlend/AdjChMute freeze
								Smeter filter time constant
		0						1 s
		1						10 ms
								ISS filter test
								ISS filter input
	0							std
	1							filter in connected to Smeter test MUXer
								ISS filter clock enable
0								clock off (test mode)
1								clock on (std)

Table 32. SUBADDRESS 17: FM IF AMP Gain, ISS center frequency, Smeter / ISS test connections

MSB				LSB				FUNCTION
D7	D6	D5	D4	D3	D2	D1	D0	
								FM IF Amp1 gain
						0	0	14 dB
						0	1	18 dB
						1	0	21.5 dB
						1	1	not used
								FM IF Amp2 gain (10.7 MHz) [byte<28>bit<6>=0]
				0	0			(7 dB) not used
				0	1			9 dB
				1	0			11 dB
				1	1			15 dB
								FM IF Amp2 gain (450 kHz) [byte<28>bit<6>=1]
				0	0			7 dB
				0	1			7 dB
				1	0			9 dB
				1	1			not used
								ISS filter center frequency
		0	0					430 kHz
		1	0					440 kHz
		0	1					450 kHz
		1	1					460 kHz
								Unfiltered Smeter test connection
	0							std
	1							unfilt Smeter users connected to #ACinL
								unfilt Smeter source disconnected form users
								ISS test MUXer connection
0								std
1								ISS test MUXer (TMODE1) connected to #SMETERTC
								Smeter filt (60ms/1s) R disconnected from #SMETERTC

Table 33. SUBADDRESS 18: PLL Test, 456KHz VCO Adjust Start, ISS MP Gain and SD OUT MODE

MSB				LSB				FUNCTION	
D7	D6	D5	D4	D3	D2	D1	D0		
								PLL TEST "testdout1" (pin #LFHC)	
					0	0	0	no test	
					0	0	1	fref [ref freq divid out]	output, 3V
					0	1	0	fsyn [VCO freq div out]	output, 3V
					0	1	1	phi [VCO prescal out]	output, 3V
					1	0	0	psm [prescal reset]	output, 3V
					1	0	1	phi	input, 3/5V
					1	1	0	fsyn	input, 3/5V
					1	1	1	sstop (cntres), fsyn	input, 3/5V
								PLL TEST "sstop" (pin #SD) (byte<21>bit<10>=01)	
					0	0	0	no test	output, 3V
					0	0	1	ifref	output, 3V
					0	1	0	zeroone	output, 3V
					0	1	1	stim	output, 3V
					1	0	0	ifcout	output, 3V
					1	0	1	fsyn	output, 3V
					1	1	0	ltst (lock det test)	output, 3V
					1	1	1	inlock	output, 3V
								456 kHz self-adjustment state machine	
				0				if byte<19>bit<0>=0 and byte<1>bit<0>=0	
				0				Waiting	
				1				START	
								Adjacent Channel detector rectifier offset	
		0	0					0.39 V	
		0	1					0.78 V	
		1	0					1.14 V	
		1	1					1.49 V	
								Quality Seek Mode	
	0							fs	
	1							Enable seek mode	
								AdjCh detector filter gain	
0								Filter 2 Gain = 8.5 dB	
1								Filter 2 Gain = 14.5 dB	

Table 34. SUBADDRESS 19: 456KHz VCO Adjustment (manual mode)

MSB							LSB	FUNCTION	
D7	D6	D5	D4	D3	D2	D1	D0		
0								Enable IFC (I ² CBUS)	OFF
1									ON
	0							Enable 456KHz VCO adj procedure (I ² CBUS)	OFF
	1								ON
		0	0	0	0	0		VCO 456KHz frequency adjust (I ² CBUS)	minfreq
		1	0	0	0	0			
		-	-	-	-	-			
		1	1	1	1	0			
		0	0	0	0	1			
		-	-	-	-	-			
		0	1	1	1	1			
		1	1	1	1	1			maxfreq
								VCO 456KHz frequency adjust mode	
							0	Manual adjustment procedure (I ² CBUS)	
							1	Automatic adjustment procedure (State Machine)	

Table 35. SUBADDRESS 20 : FM Smeter stop threshold, ISS Smeter threshold.

MSB							LSB	FUNCTION	
D7	D6	D5	D4	D3	D2	D1	D0		
								FM Smeter Stop Station threshold	
				0	0	0	0	400 mV	
				-	-	-	-	step 200 mV	
				1	1	1	1	3400 mV	
								FM ISS Smeter threshold (Δ from Softmute thresh. (*)).	
0	0	0	0					0 mV	
-	-	-	-					step 67 mV	
0	1	1	1					467 mV	
1	0	0	0					0 mV	
-	-	-	-					-	
1	1	1	1					-467 mV	

(*) Threshold is programmed by byte 14 bits<1:0> according to the following table:

Table 36. SUBADDRESS 14: Soft Mute

MSB							LSB		FUNCTION
D7	D6	D5	D4	D3	D2	D1	D0		
								Soft mute threshold	
						0	0	0.3V	
						0	1	0.4V	
						1	0	1.6V	
						1	1	1.8V	

Table 38. SUBADDRESS 22: Seek, ISS Adjacent Channel Detector

MSB				LSB				FUNCTION			
D7	D6	D5	D4	D3	D2	D1	D0				
								ISS adjacent channel detect. filter shape			
						0	0	Filt1	Filt2	Fo	Q
						0	1	HP	HP	130	2.3
						1	0	BP	HP	100	7.7
						1	1	BP	BP	177	2.0
								BP	BP	100	8.4
								ISS adjacent channel detect. filter gain			
					0			23 dB			
					1			29 dB			
								ISS adjacent channel detect. filter desens threshold at weak field strength			
			0	0				0.25 V			
			0	1				0.8 V			
			1	0				1.3 V			
			1	1				1.8 V			
								ISS adjacent channel detect. filter desens slope at weak field strength			
	0	0						min			
	0	1						-			
	1	0						-			
	1	1						max			
								Seek	FM	AM AGC2 tau	
0								Seek OFF	-	-	
1								Seek ON	ISS disable	short	

Table 39. SUBADDRESS 23: FM mixer1 adjust, FM AGC

MSB				LSB				FUNCTION			
D7	D6	D5	D4	D3	D2	D1	D0				
								FM mixer1 phase adjust.			
				0	0	0	0	-7°			
				0	0	0	1	-6°			
				0	0	1	0	-5°			
				-	-	-	-	-			
				0	1	1	1	0°			
				1	0	0	0	+1°			
				1	0	0	1	+2°			
				-	-	-	-	-			
				1	1	1	1	+8°			
								FM mixer1 gain adjust.			
		0	0					0%			
		0	1					-1%			
		1	0					1%			
		1	1					0%			
	x							FM NAGC threshold MSB (LSB in byte 26)			
								FM AGC topology			
0								NAGC on, KAGC off			
1								NAGC off, KAGC on			

Table 40. SUBADDRESS 24: XTAL adjustment, clock sep

MSB								LSB		FUNCTION	
D7	D6	D5	D4	D3	D2	D1	D0				
								XTAL ajustment capacitors from XTALG to gnd		from XTALD to gnd	
			0	0	0	0	0	0 pF		0 pF	
			0	0	0	0	1	1.25 pF		1.25 pF	
			0	0	0	1	0	2.5 pF		2.5 pF	
			0	0	1	0	0	5 pF		5 pF	
			0	1	0	0	0	10 pF		10 pF	
			1	0	0	0	0	20 pF		20 pF	
			1	1	1	1	1	38.75 pF		38.75 pF	
								XTAL test			
		0						std xtal clock			
		1						clocksep (test on)			

Table 41. SUBADDRESS 25 : Multipath DETECTOR, QUALITY OUT

MSB								LSB		FUNCTION	
D7	D6	D5	D4	D3	D2	D1	D0				
										ISS/quality MPath det. filter gain	
						0	0			-7.2 dB	
						0	1			4.3 dB	
						1	0			6.5 dB	
						1	1			10.4 dB	
										ISS MPath det. rectifier gain	
				0	0					6 dB	
				1	0					12 dB	
				0	1					18 dB	
				1	1					21.5 dB	
										Quality out MPath gain	
		0	0							off	
		0	1							-4 dB	
		1	0							0 dB	
		1	1							+4 dB	
										Quality out AdjChann gain	
0	0									off	
0	1									-4 dB	
1	0									0 dB	
1	1									+4 dB	

Table 42. SUBADDRESS 26: FM Demod Ref Frequency Test, FM AGC

MSB							LSB		FUNCTION
D7	D6	D5	D4	D3	D2	D1	D0		
								FM demod ref frequency divider	
					0	0	0	640.6 kHz	
					0	0	1	602.9 kHz	
					0	1	0	569.4 kHz	
					0	1	1	539.5 kHz	
					1	0	0	512.5 kHz	
					1	0	1	488.1 kHz	
					1	1	0	465.9 kHz (std)	
					1	1	1	445.7 kHz	
								FM WAGC starting point	
		0	0	0				minimum s.p.	
		-	-	-				-	
		0	1	0				std	
		-	-	-				-	
		1	1	1				maximum s.p.	
								FM NAGC starting point LSB (MSB is bit 6 byte 23)	
0	0							minimum s.p. (with MSB = 0)	
-	-							-	
1	0							std (with MSB = 0)	
0	0							(with MSB = 1)	
-	-							-	
1	1							maximum s.p. (with MSB = 1)	

Table 43. SUBADDRESS 27: FM Demodulator Fine Adjust , FM Demodulator Noise Blanker

MSB							LSB		FUNCTION
D7	D6	D5	D4	D3	D2	D1	D0		
								FM audio demodulator current adjust	
			0	0	0	0	0	+0 μ A	
			0	0	0	0	1	+0.167 μ A	
			-	-	-	-	-	-	
			0	1	1	1	1	+2.51 μ A	
			1	0	0	0	0	-0 μ A	
			1	0	0	0	1	-0.167 μ A	
			1	-	-	-	-	-	
			1	1	1	1	1	-2.51 μ A	
								FM Demodulator Noise Blanker	
	0	0						NB off	
	0	1						setting 1	
	1	0						setting 2	
	1	1						setting 3	

Table 44. SUBADDRESS 28 : Smeter slider, External WB, testing

MSB				LSB				FUNCTION	
D7	D6	D5	D4	D3	D2	D1	D0		
								Smeter slider FM	AM
		0	0	0	0	0	0	0 mV	0 mV
		0	0	0	0	0	1	+46 mV	+39 mV
		-	-	-	-	-	-	-	-
		0	1	1	1	1	1	+1420 mV	+1215 mV
		1	0	0	0	0	0	0 mV	0 mV
		1	0	0	0	0	1	-46 mV	-39 mV
		-	-	-	-	-	-	-	-
		1	1	1	1	1	1	-1420 mV	-1215 mV
								External WB filter on	
	0							std FM (no ext. WB filter)	
	1							external WB filter enabled; must also program ISS on APSDlatch 23 bit 1 = 1	
								FM demod Vout test	
0								std	
1								test; disconnect FM demod Vout from users	

Table 45. SUBADDRESS 29: AM stop station, AM IF 2 Amplifier Gain

MSB				LSB				FUNCTION	
D7	D6	D5	D4	D3	D2	D1	D0		
								AM Stop Station threshold	
				0	0	0	0	300 mV	
				0	0	0	1	450 mV	
				0	0	1	0	600 mV	
				-	-	-	-		
				1	1	1	1	2550 mV	
								AM IF AMP Gain (AM mode) [dB]	FM demodulator input connection (bit 5)
0	0	0	0					Not used (31.1)	450 kHz limiter
0	0	1	0					67.6	stereo dec. 456 kHz VCO (test)
0	1	0	0					70.6	450 kHz limiter
0	1	1	0					74.7	stereo dec. 456 kHz VCO (test)
1	0	0	0					72.2	...
1	0	1	0					75.6	...
1	1	0	0					76.9	...
1	1	1	0					78.8	...
0	0	0	1					75.3	...
0	0	1	1					77.7	...
0	1	0	1					78.7	...
0	1	1	1					80.2	...
1	0	0	1					79.3	...
1	0	1	1					80.7	...
1	1	0	1					81.3	...
1	1	1	1					82.3	...

Table 46. SUBADDRESS 30: IFT Adjust, AM Fast AGC2, ARS, WB Narrow Smeter/IFC

MSB				LSB				FUNCTION
D7	D6	D5	D4	D3	D2	D1	D0	
				0	0	0	0	IFT1 Adjust 0 pF
				0	0	0	1	0.55 pF
				-	-	-	-	-
				0	1	1	1	7.7 pF
				1	1	1	1	8.25 pF
								WX narrow SM&IFC
			0					off
			1					on
								ARS - ISS indicator
		0						off
		1						on
								AM fast AGC2 enable
	0							off
	1							on -> (if Vaudio-Vref > 1.5 V then fast on)

Table 47. SUBADDRESS 31 : AM IF NB

MSB				LSB				FUNCTION
D7	D6	D5	D4	D3	D2	D1	D0	
								AM IF NB threshold
				0	0	0	0	0 mV
				0	0	0	1	46 mV
				0	0	1	0	100 mV
				0	0	1	1	146 mV
				0	1	0	0	212 mV
				0	1	0	1	257 mV
				0	1	1	0	312 mV
				0	1	1	1	362 mV
				1	0	0	0	439 mV
				1	0	0	1	485 mV
				1	0	1	0	541 mV
				1	0	1	1	587 mV
				1	1	0	0	653 mV
				1	1	0	1	700 mV
				1	1	1	0	755 mV
				1	1	1	1	800 mV
								AM IF NB disable threshold
		0	0					4.4 V
		0	1					2.2 V
		1	0					0.5 V
		1	1					OFF

4.10 Section 2 (Stereodecoder, Audioprocessor + Tuner)Section 1 (Turner)

Table 48. ADDRESS

MSB							LSB
D7	D6	D5	D4	D3	D2	D1	D0
1	0	0	0	1	1	0	R/W

Table 49. SUBADDRESS

MSB						LSB	
S7	S6	S5	S4	S3	S2	S1	S0
testcon	azhold	autoincr	subaddress				

www.DataSheet4U.com

4.11 READ MODE: ISS OUTPUT

MSB							LSB
S7	S6	S5	S4	S3	S2	S1	S0
SMETER ADC						STEREO	SMON

Table 50. AUDIO PROCESSOR / STEREO DECODER - RELATED BYTES

Subaddr.	MSB							LSB	Function
	D7	D6	D5	D4	D3	D2	D1	D0	
0	loudness gain correctionl	input gain			source selector			Source selector,	
1	soft step	volume steps						Volume	
2	soft step	loudness gain pass corner frequency	loudness steps				loudness		
3	speaker coupling	treble center frequency	treble steps				Treble		
4	soft step	bass quality factor	bass steps				Bass		
5	soft step	Speaker steps						Speaker Left Front	
6	soft step	Speaker steps						Speaker LRight Front	
7	soft step	Speaker steps						Speaker Left Rear	
8	soft step	Speaker steps						Speaker Right Rear	
9	rear seat audio on	bass DC cut	bass center frequency	mute (*)		soft mute time	mute (*)	Configuration Audio Processor 1	
10	rear seat audio selector		loudness freq. resp.	soft step time		loudness low pass corner frequency	loudness treble boost	Configuration Audio Processor II	
11	beep frequency		AZ on	chime dis				mute (*)	Configuration Audio Processor III
				RR	LR	RF	LF		
12	de-emph time constant	pilot threshold	NB peak charge cur	force mono	NB AM fix threshold	Std In Gain		mute (*)	Stereo decoder II, NB II
13	MP infl. on NB enable	NB dis. from MP (test)	NB AM HPF order	NB AM HPF corner	roll-off compensation			Stereo decoder III, NB IV	

Table 50. AUDIO PROCESSOR / STEREO DECODER - RELATED BYTES

Subaddr.	MSB						LSB		Function
	D7	D6	D5	D4	D3	D2	D1	D0	
14	NB overdev-contr thr.		NB on	NB noise-contr. thr.		NB low threshold		NB III	
15	NB time		MP infl. on NB		VHCH shift			Stereo decoder III, NB IV	
16	Strong MP infl. on NB enable	VHCL		VHCH		max HC		HCenable Stereo decoder IV, NB V	
17	AM/FM for STD	ADC on	HC from SNC/lev	NB level-contr. thr.		NB Smeter thresholds		STD in switch AM/FM mode selection, Stereo decoder V, NB VI	
18	HC fixed	HC min/max	AM 7.2kHz LPF	HC corner freq.				Stereo decoder VI	
19	AP test on	VCO on	Std test muxer			ext. clock	Std teston	APSD test	
TUNER-RELATED BYTES									
20	"ac+" - "ac" thresholds difference	"ac" threshold			not used		ISS 20KHz on	ISS: Adjacent Channel detector	
21	ISS MP defeat AC	not used	not used	ISS MP threshold		not used		ISS MP ctrl on ISS: Multipath detector	
22	not used	dev+/dev thresholds ratio		"dev" threshold		peak detector discharge current		ISS: Deviation detector	
23	not used	not used	ISS time constant			ISS 80/120	ISS ON	ISS enable ISS Filter	
24	MP/AC test switch			ISS test multiplexing			ISS test		
25	ISS filter control matrix						ISS filter control matrix		
26	ISS filter control matrix						ISS filter control matrix		
27	not used	not used	not used	ISS filter control matrix				ISS filter control matrix	
28	not used	not used	not used	HC range		VSBL		VSBL generation, HC range	

Table 51. SUBADDRESS 0: Input selector

MSB					LSB			FUNCTION
D7	D6	D5	D4	D3	D2	D1	D0	
								Source Selector
					0	0	0	Quasi differential input
					0	0	1	Mono differential input
					0	1	0	Single ended input
					0	1	1	Turner
					1	0	0	Turner
					1	0	1	internal beep
					1	1	0	mute
					1	1	1	not allowed
								Input Gain
	0	0	0	0				0dB
	0	0	0	1				1dB
	-	-	-	-				-
	1	1	1	0				14dB
	1	1	1	1				15dB
								Loudness filter gain correction
0								higher gain
1								lower gain

Table 52. Subaddress 1,4,5,6,7: Volume Spkr atten. LF, RF, LR, RR

MSB				LSB				FUNCTION
D7	D6	D5	D4	D3	D2	D1	D0	
								Gain/Attenuation
	0	0	0	1	1	1	1	15dB
	-	-	-	-	-	-	-	-
	0	0	0	0	0	0	1	1dB
	0	0	0	0	0	0	0	0dB
	0	0	1	0	0	0	0	0dB
	0	0	1	0	0	0	1	-1dB
	-	-	-	-	-	-	-	-
	0	1	0	0	0	0	0	-16dB
	-	-	-	-	-	-	-	-
	0	1	1	0	0	0	0	-32dB
	-	-	-	-	-	-	-	-
	1	0	0	0	0	0	0	-48dB
	-	-	-	-	-	-	-	-
	1	0	1	0	0	0	0	-64dB
	-	-	-	-	-	-	-	-
	1	0	1	1	1	1	0	-79dB
	1	1	X	X	X	X	X	mute
								Bass filter DC modeSoft Step On/Off
0								On
1								Off

Table 53. SUBADDRESS 2: Loudness

MSB				LSB				FUNCTION
D7	D6	D5	D4	D3	D2	D1	D0	
								Attenuation
			0	0	0	0	0	0 dB
			0	0	0	0	1	-1 dB
			0	0	0	1	0	-2 dB
		
			1	0	0	1	1	-19 dB
			1	0	1	0	0	-20 dB
								all higher values not allowed
								Loudness High Pass Corner Freq.
	0	0						4 kHz
	0	1						6 kHz
	1	0						8 kHz
	1	1						10 kHz
								Soft Step On/Off
0								On
1								Off

Table 54. Subaddress 3: Treble Filter

MSB								LSB		FUNCTION
D7	D6	D5	D4	D3	D2	D1	D0			
									Gain/Attenuation	
			0	0	0	0	0	-15dB		
			0	0	0	0	1	-14dB		
			-	-	-	-	-	-		
			0	1	1	1	0	-1dB		
			0	1	1	1	1	0dB		
			1	1	1	1	1	0dB		
			1	1	1	1	0	1dB		
			-	-	-	-	-	-		
1	1		1	0	0	0	1	-14dB		
			1	0	0	0	0	-15dB		
									Center Frequency	
	0	0						10.0kHz		
	0	1						12.5kHz		
	1	0						15kHz		
	1	1						17.5kHz		
									Speaker Coupling	
0								External (AC)		
1								Internal (DC)		

Table 55. Subaddress 4: Bass Filter

MSB								LSB		FUNCTION
D7	D6	D5	D4	D3	D2	D1	D0			
									Gain/Attenuation	
			1	1	1	1	1	-15dB		
			1	1	1	1	0	-14dB		
			-	-	-	-	-	-		
			1	0	0	0	1	-1dB		
			1	0	0	0	0	0dB		
			0	0	0	0	0	0dB		
			0	0	0	0	1	1dB		
			-	-	-	-	-	-		
			0	1	1	1	0	-14dB		
			0	1	1	1	1	-15dB		
									Quality Factor	
	0	0						1.00		
	0	1						1.25		
	1	0						1.50		
	1	1						2		
									Bass Soft Step	
0								off		
1								on		

Table 56. SUBADDRESS 9: Configuration Audio Processor I

MSB							LSB	FUNCTION
D7	D6	D5	D4	D3	D2	D1	D0	
								AP I²C Soft mute
							0	force AP I ² C mute (*)
							1	allow AP mute from pin (*)
								Soft Mute Time
					0	0		Mute time = 0.48ms
					0	1		Mute time = 0.96ms
					1	0		Mute time = 20.2 ms
					1	1		Mute time = 40.4 ms
								STD mute ctrl.from AP mute
				0				enabled (*)
				1				disabled (*)
								Bass Center frequency
		0	0					60 Hz
		0	1					80 Hz
		1	0					100 Hz
		1	1					130 Hz
								Bass DC cut
	0							on
	1							off
								Rear seat audio
0								on
1								off

(*) cfr. APSD MUTE table

Table 57. SUBADDRESS 10: Configuration Audio Processor II

MSB							LSB	FUNCTION
D7	D6	D5	D4	D3	D2	D1	D0	
								Loudness Treble Boost
							0	on (advise bit7 byte10 = 1)
							1	off (advise bit7 byte10 = 0)
								Loudness Low Pass Corner Freq.
					0	0		32.5 Hz
					0	1		40 Hz
					1	0		150 Hz
					1	1		Not used (150 Hz)
								Soft Step Time
			0	0				280 us
			0	1				560 us
			1	0				1.12 ms
			1	1				2.24 ms
								Loudness Frequency Response
		0						Filter on
		1						Filter flat (can be used as an attenuator)
								Rear Seat Audio Selector
0	0							quasi differential input
0	1							single ended input
1	0							tuner
1	1							mute

Table 58. SUBADDRESS 11: Configuration Audio Processor III

MSB							LSB		FUNCTION
D7	D6	D5	D4	D3	D2	D1	D0		
								APSD mute ctrl. from pin	
								0	pin influence disabled (*)
								1	pin influence enabled (*)
								Chime mix Left Front	
								0	on
								1	off
								Chime mix Right Front	
								0	on
								1	off
								Chime mix Left Rear	
								0	on
								1	off
								Chime mix Right Rear	
								0	on
								1	off
								Auto Zero enable	
								0	off
								1	on (0->1 causes AZ sequence to start; 1 enables sequence control from latch<0>)
								Beep Frequencies	
0	0							500 Hz	
0	1							1000 Hz	
1	0							2000 Hz	
1	1							3000 Hz	

(*) cfr. APSD MUTE table

Table 59. SUBADDRESS 12: Stereodecoder

MSB							LSB		FUNCTION
D7	D6	D5	D4	D3	D2	D1	D0		
								STD I²C mute (high-ohmic + PLL hold)	
								0	force STD I ² C mute (*)
								1	allow STD mute ctrl. from pin
								STD In Gain	
								0 0	+5.75 dB
								0 1	+4.00 dB
								1 0	+2.25 dB
								1 1	+0.50 dB
								0	NB AM old mode (if AM=1)
								1	NB AM new mode (if AM=1)
								0	Force Mono
								1	Mono/Stereo switch automatically
								Noise Blanker PEAK charge current	
								0	low
								1	high
									Pilot detector threshold
								0	high
								1	low
								Deemphasis time constant FM AM (dep. on source selector)	
								0	50 us 14.9 kHz
								1	75 us 22.3 kHz

(*) cfr. APSD MUTE table

Subaddress 13: Stereodecoder Noise Blanker

MSB				LSB				FUNCTION
D7	D6	D5	D4	D3	D2	D1	D0	
								Roll Off Compensation
				0	0	0	0	Not allowed
				0	0	0	1	7.2%
				0	0	1	0	9.4%
			
				0	1	0	0	13.7%
			
				0	1	1	1	20.2%
				1	0	0	0	Not allowed
				1	0	0	1	19.6%
				1	0	1	0	21.5%
			
				1	1	0	0	25.3%
			
				1	1	1	1	31%
								NB AM High pass Frequency
			0					10 kHz
			1					20 kHz
								NB AM High pass filter order
		0						First order
		1						Second order
								Disable Noise Blanker @ MP > 2.5 V (test)
	0							ON
	1							OFF
								Multipath influence on fixed NB noise detector discharge resistor
0								disabled
1								enabled

Table 60. SUBADDRESS 14: Noise Blanker

MSB				LSB				FUNCTION	
D7	D6	D5	D4	D3	D2	D1	D0		
								Low Threshold (FM)	(AM)
					0	0	0	65 mV	166%
					0	0	1	60 mV	156%
					0	1	0	55 mV	147%
					0	1	1	50 mV	137%
					1	0	0	45 mV	128%
					1	0	1	40 mV	118%
					1	1	0	35 mV	109%
					1	1	1	30 mV	99%
								Noise Controlled Threshold	
			0	0				320 mV	
			0	1				260 mV	
			1	0				200 mV	
			1	1				140 mV	
		0						Noise blanker OFF	
		1						Noise blanker ON	
								Over deviation threshold	
0	0							Over deviation adjust 2.8V	
0	1							Over deviation adjust 2.0V	
1	0							Over deviation adjust 1.2V	
1	1							Over deviation detector OFF	

Table 61. SUBADDRESS 15: Noiseblanker & High Cut

MSB				LSB				FUNCTION	
D7	D6	D5	D4	D3	D2	D1	D0		
								VHCH Shift ("a" factor) (**)	
				0	0	0	1	97%	
				0	0	1	0	73%	
				0	1	0	0	50%	
				1	0	0	0	32%	
								Strong multipath-controlled Noise Rectifier Discharge Resistor (if bit7 byte 16 = 1)	
		0	0					R = infinity	
		0	1					R = 56Mohm	
		1	0					R = 33Mohm	
		1	1					R = 18Mohm	
								Noise Blanker Time	
								FM	AM
0	0							34 us	1130 us
0	1							24 us	755 us
1	0							29 us	950 us
1	1							22 us	651 us

(**)cf. HCC/SB threshold table

Table 62. SUBADDRESS 16: Noiseblanker

MSB							LSB	FUNCTION
D7	D6	D5	D4	D3	D2	D1	D0	
								High cut enable
							0	High Cut OFF (fixed to max corner freq.)
							1	High Cut ON
								Max. High Cut (***)
					0	0		max N "4"
					0	1		max N "13"
					1	0		max N "20"
					1	1		max N "31"
								VHCH ("b" factor) (**)
			0	0				67%
			0	1				75%
			1	0				83%
			1	1				92%
								VHCL ("c" factor) (**)
	0	0						20%
	0	1						25%
	1	0						30%
	1	1						35%
								Strong multipath influence on rectifier discharge current
0								disabled
1								enabled

(**) cfr. HCC/SB threshold table

(***) lower limit for possible automatic HC filter position; frequency is given by the following formula:

$$f_p = \frac{1}{\frac{1}{f_{\max}} + \frac{N}{31} \left(\frac{1}{f_{\min}} - \frac{1}{f_{\max}} \right)}$$

with N given by the software table above the minimum HC filter pole frequency depends on the HC range selected (see byte 28 bits <4:3>)

Table 63. SUBADDRESS 17: High cut, Noise Blanker, ADC, Stdec in Switch

MSB							LSB		FUNCTION
D7	D6	D5	D4	D3	D2	D1	D0		
								Stereo decoder input switch	
							0	switch closed (signal can go into stereo decoder)	
							1	switch open (signal can not gon into stereo decoder)	
								Minimun and maximun Smeter thresholds for NB	
					0	0		2.2 , 4.3	
					0	1		3.2 , 4.6	
					1	0		2.7 , 4.5	
					1	1		3.7 , 4.7	
								NB max PEAK value generated from Smeter	
			0	0				1.8 V	
			0	1				1.5 V	
			1	0				1.1 V	
			1	1				OFF	
								HCC threshold generation mode (VHCH, VHCL)(**)	
		0						SNC OFF	
		1						SNC ON	
								Smeter ADC operation	
	0							ADC Convert Stop	
	1							ADC Convert Start	
								AM/FM mode selection for StereoDecoder	
0								FM mode	
1								AM mode	

(**) cfr. HCC/SB threshold table

Table 64. SUBADDRESS 18: High Cut

MSB							LSB		FUNCTION
D7	D6	D5	D4	D3	D2	D1	D0		
								Max/Min High Cut Frequency (***)	
			0	0	0	0	0	20 kHz/ 10 kHz	
			0	0	0	0	1	.	
				
			1	1	1	1	1	4 kHz/ 2 kHz	
		0						AM 7.2kHz LPF OFF	
		1						AM 7.2kHz LPF ON	
								High Cut Filter limiting (AM)	
	0							Fix Maximum High Cut Frequency	
	1							Fix Minimum High Cut Frequency	
0								Fixed High Cut OFF	
1								Fixed High Cut ON	

(***) High Cut LPF corner frequency formula:

$$f_{hicut} = f_{max} / (1 + N / 7.75)$$

with N = 0,1,...,31

and fmax = 4 kHz, 10 kHz or 20 kHz according to byte 28 bit 3 and 4

Table 65. SUBADDRESS 19: Stereo Decoder Test Multiplexer

MSB							LSB		FUNCTION
D7	D6	D5	D4	D3	D2	D1	D0		
Stereo Decoder test signals									
							0	OFF	
							1	Test signals enabled (if D7 of subaddress is also) "1"	
						0		External Clock	
						1		Internal Clock	
								Test signals	
		0	0	0	0			VHCCH	
		0	0	0	1			Smeter for ADC	
		0	0	1	0			Pilot Magnitude	
		0	0	1	1			VCO control voltage	
		0	1	0	0			Pilot Threshold	
		0	1	0	1			HOLDN	
		0	1	1	0			NB Threshold	
		0	1	1	1			F228	
		1	0	0	0			VHCCL	
		1	0	0	1			VSBL	
		1	0	1	0			Level for NB	
		1	0	1	1			HCC input	
		1	1	0	0			PEAK	
		1	1	0	1			SB input	
		1	1	1	0			REF 5V	
		1	1	1	1			F228	
								400kHz VCO OFF	
	0							ON	
	1							OFF	
								Audioprocessor test mode	
0								OFF	
1								Enabled if D7 of subaddress is also "1"	

Table 66. SUBADDRESS 20: ISS Weather Band Controls and Adjacent Channel thresholds

MSB							LSB		FUNCTION
D7	D6	D5	D4	D3	D2	D1	D0		
ISS weather band									
							0	ISS filter 20KHz (weather band) OFF	
							1	ISS filter 20KHz (weather band) ON	
						x		not used	
					x			not used	
"ac" threshold (+ Ref3V)									
		0	0	0				0.25 V	
		0	0	1				0.35 V	
		0	1	0				0.45 V	
		-	-	-				-	
		1	1	1				0.95 V	
"ac+" - "ac" thresholds difference									
0	0							0.0 V	
0	1							0.1 V	
1	0							0.2 V	
1	1							0.3 V	

Table 67. SUBADDRESS 21: ISS Multipath

MSB							LSB		FUNCTION
D7	D6	D5	D4	D3	D2	D1	D0		
								Multipath control	
							0	ON	
							1	OFF	
						x		not used	
					x			not used	
								MP threshold	
			0	0				0.50 V	
			0	1				0.75 V	
			1	0				1.00 V	
			1	1				1.25 V	
		x						not used	
	x							not used	
0								MP=1 disables "ac+" detection	
1								MP=1 disables "ac" and "ac+" detection	

Table 68. SUBADDRESS 22: ISS Deviation Thresholds

MSB							LSB		FUNCTION
D7	D6	D5	D4	D3	D2	D1	D0		
								peak detector discharge current	
					0	0	0	6uA	
					0	0	1	8uA	
					0	1	0	10uA	
					0	1	1	12uA	
					1	0	0	14uA	
					1	0	1	16uA	
					1	1	0	18uA	
					1	1	1	20uA	
								"dev" threshold	
			0	0				30 kHz	
			0	1				45 kHz	
			1	0				60 kHz	
			1	1				75 kHz	
								dev+ / dev thresholds ratio	
	0	0						1.5	
	0	1						1.4	
	1	0						1.3	
	1	1						1.0	
x								not used	

Table 69. SUBADDRESS 23: ISS Detector

MSB							LSB		FUNCTION
D7	D6	D5	D4	D3	D2	D1	D0		
								ISS Enable (active low)	
								0	ON
								1	OFF
								ISS filter ON/OFF manual control	
								0	OFF
								1	ON
								ISS Filter Bandwidth manual control	
								0	120 kHz
								1	80 kHz
								discharge current;charge current mid; narrow	
		0	0	0					1uA; 74uA; 124uA
		0	0	1					3uA; 72uA; 122uA
		0	1	0					5uA; 70uA; 120uA
		1	0	0					9uA; 66uA; 116uA
		1	1	1					15uA; 60uA; 110uA
x	x								not used

Table 70. SUBADDRESS 24: ISS Test

MSB							LSB		FUNCTION
D7	D6	D5	D4	D3	D2	D1	D0		
								ISS test muxer selector (test signal at pin SMETERTC if bit7 byte17 tuner software is 1)	
				0	0	0	1	MPthreshold	
				0	0	1	0	ACNthreshold ("ac" threshold)	
				0	0	1	1	Dwthreshold ("dev" threshold)	
				0	1	0	0	Dthreshold ("dev+" threshold)	
				0	1	0	1	ACWthreshold ("ac+" threshold)	
				0	1	1	0	ac	
				0	1	1	1	MDSCO	
				1	0	0	0	ISS out	
				1	0	0	1	dev+	
				1	0	1	0	dev	
				1	0	1	1	refdev	
				1	1	0	0	DEMVout output if bit 7 byte 28 tuner = 0 input if bit 7 byte 28 tuner = 1	
								ISS AC/MP test mode (pin SD)	
			0						Internal AC signal is connected to QUALIDETECTOR AC input (normal mode)
			1						Internal AC signal is output to pin SD (test mode)
		0							QUALIDETECTOR AC input is driven by internal AC signal (normal mode)
		1							QUALIDETECTOR AC input is driven by pin SD (test mode)
	0								Internal MP signal is connected to QUALIDETECTOR MP input (normal mode)
	1								Internal MP signal is output to pin SD (test mode)
0									QUALIDETECTOR MP input is driven by internal MP signal (normal mode)
1									QUALIDETECTOR MP input is driven by pin SD (test mode)

Table 71. SUBADDRESSES 25-27: ISS Filter Control Matrix

Strong field (Sm = 0)			
Truth table for ISSon	small frequency deviation	medium frequency deviation	large frequency deviation
No adjacent channel	0	0	0
Weak adjacent channel	byte 25 / bit 0	byte 25 / bit 1	byte 25 / bit 2
Strong adjacent channel	1	byte 25 / bit 3	byte 25 / bit 4
Truth table for ISS80	small frequency deviation	medium frequency deviation	large frequency deviation
No adjacent channel	0	0	0
Weak adjacent channel	byte 25 / bit 5	byte 25 / bit 6	0
Strong adjacent channel	byte 25 / bit 7	byte 26 / bit 0	byte 26 / bit 1

Table 72.

Weak field (Sm = 1)			
Truth table for ISSon	small frequency deviation	medium frequency deviation	large frequency deviation
No adjacent channel	1	byte 26 / bit 2	0
Weak adjacent channel	1	byte 26 / bit 3	byte 26 / bit 4
Strong adjacent channel	1	1	byte 26 / bit 5
Truth table for ISS80	small frequency deviation	medium frequency deviation	large frequency deviation
No adjacent channel	byte 26 / bit 6	byte 26 / bit 7	0
Weak adjacent channel	byte 27 / bit 0	byte 27 / bit 1	byte 27 / bit 2
Strong adjacent channel	1	byte 27 / bit 3	byte 27 / bit 4

Table 73. SUBADDRESS 28: VSBL Generation, HC Range

MSB							LSB	FUNCTION
D7	D6	D5	D4	D3	D2	D1	D0	
								VSBL ("d" factor) (**)
					0	0	0	29%
					0	0	1	33%
					0	1	0	38%
					0	1	1	42%
					1	0	0	46%
					1	0	1	50%
					1	1	0	54%
					1	1	1	58%
								High Cut filter range
			0	0				20 kHz - 4 kHz
			0	1				10 kHz - 2 kHz
			1	0				4 kHz - 800 Hz
			1	1				4 kHz - 800 Hz

Table 74. Audio Processor / Stereo Decoder Mute

BYTE 9	BYTE 9	BYTE 11	BYTE 12	pin	status	status
BIT 0	BIT 3	BIT 0	BIT 0	55	AP	STD
0	0	0	0	0	mute	mute
0	0	0	0	1	mute	mute
0	0	0	1	0	mute	mute
0	0	0	1	1	mute	mute
0	0	1	0	0	mute	mute
0	0	1	0	1	mute	mute
0	0	1	1	0	mute	mute
0	0	1	1	1	mute	play
0	1	0	0	0	mute	mute
0	1	0	0	1	mute	mute
0	1	0	1	0	mute	play
0	1	0	1	1	mute	play
0	1	1	0	0	mute	mute
0	1	1	0	1	mute	mute
0	1	1	1	0	mute	mute
0	1	1	1	1	mute	play
1	0	0	0	0	play	mute
1	0	0	0	1	play	mute
1	0	0	1	0	play	play
1	0	0	1	1	play	play
1	0	1	0	0	mute	mute
1	0	1	0	1	play	mute
1	0	1	1	0	mute	mute
1	0	1	1	1	play	play
1	1	0	0	0	play	mute
1	1	0	0	1	play	mute
1	1	0	1	0	play	play
1	1	0	1	1	play	play
1	1	1	0	0	mute	mute
1	1	1	0	1	play	mute
1	1	1	1	0	mute	mute
1	1	1	1	1	play	play

byte 12 bit 0 = 0 force I²Cbus STD mute

byte 9 bit 0 = 0 force I²Cbus AP mute

11 bit 0 = 1 AP / STD mute depends on pin

HCC control from SNC

$$VHCH = 2V + 3V * a * b$$

$$VHCL = 2V + 3V * a * b * c$$

HCC control from level

(level = Smeter * 0.7)

$$VHCH = ab \ 4V$$

$$VHCL = abc \ 4V$$

SBL

$$VSBL = 2V + d \ 3V$$

5 FUNCTIONAL DESCRIPTION

5.1 FM TUNER SECTION

5.1.1 FRONT END

The FM tuner section features an image rejection mixer. Its low noise figure allows connecting the antenna to the mixer without any discrete preamplifier. The external preselection circuit can be realized with one tuned filter only. The filter can be electrically aligned by shifting the filter tuning voltage with respect to the VCO tuning voltage through an 8 bit DAC.

The mixer image rejection trimming is obtained by tuning the relative phase offset and relative gain of the I and Q mixer paths. The mixer output (common with the AM 1st mixer output) is connected to a tuned IF transformer, with the possibility of electrically adjusting the center frequency through an internal 4 bit capacitor bank.

The FM AGC can operate in two different software-selectable modes:

- Keyed Wide band mode: the AGC detects the strength of the wide band RF signal at the input of the 1st mixer to activate the AGC attenuation; the starting point is programmable via software and is varied over a >40 dB range by the very narrow band Smeter signal in order to set a maximum suppression limit that prevents the desired channel from decreasing below an acceptable level;
- Wide band + Narrow band mode: the AGC detects the strength of both the wide band RF signal at the input of the 1st mixer and of the narrow band IF signal at the output of the IFT1 (both starting points are software-programmable); this mode allows a smooth transition between near adjacent and far adjacent suppression.

The AGC features a single current output used to drive the front end P-I-N diode attenuator.

5.1.2 IF FILTERING

FM channel selection is mainly done by use of external ceramic filters. Two different software-programmable configurations are available:

- normal FM mode: three ceramic filters can be connected using two impedance-matched IF amplifiers (both with programmable gains); the third ceramic filter is connected to the 2nd mixer input;
- high-performance Weather Band applications: when an optimum Weather Band channel selection is required, the TDA7514 allows to connect a dedicated narrow band external 450 kHz ceramic filter to implement this function. In this case only two 10.7 MHz ceramic filters can be connected for standard FM selectivity. The 1st ceramic filter is normally connected between the IFT1 output and the 1st IF amplifier input; the 2nd ceramic filter is connected between the 1st IF amplifier input and the 2nd mixer input; the 450 kHz WB filter is connected between the 2nd IF amplifier output and the 2nd IF amplifier input. Both the single standard FM IF amplifier gain and the 450 kHz WB filter driver IF amplifier gain are software programmable.

5.1.3 LIMITING AND DEMODULATION

The TDA7514 features a fully integrated FM demodulator which requires a lower IF than 10.7 MHz. Therefore a 2nd mixer is provided to down-convert IF1 down to 450 kHz. The 10.25 MHz frequency needed to drive the 2nd mixer is provided by the XTAL oscillator. Limiting is performed at IF2 through a 5 stage limiter. The demodulator exhibits a very linear frequency-voltage conversion. Precise cancellation of the demodulator output voltage offset is available via software control especially for high audio gain WB applications.

Field strength measurement (Smeter) is performed through use of a separate IF1 limiter and logarithmic amplifier. The IF1 limiter output is also used to feed the FM IF counter block.

VARIABLE-BANDWIDTH SELECTIVITY SYSTEM (ISS)

The TDA7514 is equipped with the Intelligent Selectivity System that automatically performs IF bandwidth reduction in presence of strong adjacent channels or weak desired signal. A three position filter is available at IF2; its bandwidth settings are: 120 kHz, 80 kHz and 22 kHz (the latter only for additional on-board WB filtering). The filter is positioned between the 2nd mixer and the IF2 limiter. The filter is switched among its OFF, 120 kHz and 80 kHz positions by a dedicated quality detection circuit.

The conditions that are detected in order to drive the filter position are:

- adjacent channel presence;
- peak frequency deviation magnitude;
- field strength.

The adjacent channel detection (programmable filter shape and gain, programmable rectifier gain, programmable flag generation thresholds, programmable integrator charge/discharge currents) can be partially or totally disabled, if so programmed, when a strong multipath condition is detected (filter shared with quality circuits with programmable gain, independent rectifier with programmable gain, programmable intervention threshold). The adjacent channel detector is further disabled when the field strength is lower than a programmable threshold (slope programmable as well). The output of the detector are two flags signalling a moderate or a strong adjacent channel presence.

The peak frequency deviation is detected by rectifying and peak-detecting the mono part of the MPX signal (programmable integrator charge/discharge currents, programmable thresholds). The deviation detector is desensitized at weak field strength (programmable threshold). The output of the detector are two flags signalling a moderate or high amount of peak deviation.

The field strength is measured against a programmable threshold and generates one flag.

These five flags are combined to control the ISS bandwidth by access to a 3-D matrix that can be programmed almost completely: it is therefore possible to specify the filter bandwidth for almost all the possible flag combinations.

The ISS filter may be disabled by setting the tuner SEEK bit to "1".

5.1.4 SOFT MUTE AND MPX OUTPUT

The demodulator output is passed through muting attenuators before becoming available externally for the connection to the stereo decoder. The muting and output buffering are shared with the AM circuit.

The FM muting circuit is sensitive to weak field strength and to the presence of adjacent channel. The weak field strength condition (soft mute) is detected by comparing the 1 second-filtered Smeter with a programmable threshold. The soft mute depth and slope are software-programmable.

The soft mute is followed by the adjacent channel muting circuit. The presence of adjacent channel is detected as high frequency noise in the MPX signal, so that only the adjacent channel that is not suppressed by the ISS can activate this muting. The filter is described in the Quality section. It is desensitized under weak field strength conditions. The adjacent channel mute threshold/slope and depth are programmable.

The output audio amplifier gain can be switched to a +23.5 dB setting in WB in order to equalize the FM and WB 100% modulation audio levels.

ISS-dependent automatic roll-off compensation is implemented before the output buffer.

5.1.5 STATION DETECTION

The station detection function makes use of signal strength measurement and of IF counting. The result is available on the SD pin as a logic high value when the tuned channel is considered valid. On the SD pin the two field strength-related and IF counter output signals are also available separately by suitably programming the output multiplexer.

The field strength-related digital output is derived by comparison of the filtered Smeter (the time constant is 1s in reception and 100us in seek mode - see Quality section) with a programmable threshold.

The FM IF counter circuit detects whether the IF signal is centered inside a programmable frequency window around the nominal frequency value. The measuring time window is programmable as well. The result

is available both on the SD pin and in the tuner I²C bus read byte.

5.1.6 QUALITY

The FM quality section of the TDA7514 generates the control signals for all the quality-related functions. These quality signals are: filtered Smeter, adjacent channel content, multipath content. The controlled functions are: AGC keying, soft mute, adjacent channel mute, stereo blend, high cut, audio noise blanker.

Externally available quality signals are also generated by this circuit. These signals are: filtered Smeter (analog and digital), adjacent channel content and multipath content.

External filtering to generate part of the quality signals uses external capacitors: the voltage values on these capacitors can be kept stored during RDS AF update or fast charged when a new tuned frequency is selected.

The Smeter filter uses an external capacitor to generate a low-pass time constant of 1 s in reception mode (10 ms for fast car-radio testing), and an all-internal circuit for a low-pass time constant of 100 μ s for RDS AF update. The voltage across the capacitor is stored during RDS AF update; it is fast charged following the 100 μ s-filtered signal during jumps to a new frequency. The 1s/100 μ s Smeter is fed to the station detector, to the high cut filter, to the soft mute and to the A-to-D converter.

An internally filtered 1ms-time constant Smeter is further generated to drive the keyed AGC, the ISS and the weak field filter desensitization circuits.

The stereo blend function is driven by a combination of weak signal strength-, adjacent channel- and multipath-related information through the SNC (stereo noise control) signal. The SNC signal is a wired-OR of the three conditions and is generated with a peak holder featuring a 400 ms attack time constant and a 10 s decay time constant. The Smeter contribution to the SNC is programmable in terms of gain and offset; the same is true for the two other bad quality indicators (filter shape, rectifier offset and gain are programmable) keeping in mind that the adjacent channel filter and rectifier are shared with the adjacent channel mute circuit and that the multipath filter is shared with the ISS multipath detector. The voltage across the external SNC filtering capacitor is stored during RDS AF update, and is driven by a fast charge circuit during jumps to a new frequency. A fast car-radio test mode is also available in which the external capacitor is disconnected and substituted for by a much smaller internal capacitor.

A faster attack of the stereo blend function in case of sudden onset of adjacent channel or multipath conditions is ensured by actually driving the stereo blend circuit by a further wired-OR circuit sensing the SNC voltage as well as the unfiltered multipath and adjacent channel rectifier outputs.

The quality signals available to the u-processor are: filtered Smeter (on the dedicated buffered SMETER pin), the multipath information (on pin QUALMPOUT), a programmable combination of multipath and adjacent channel information (on pin QUALACMPOUT), and 6 bit digitized filtered Smeter (via the tuner I²C bus read byte).

5.2 AM TUNER SECTION

5.2.1 FRONT END

The AM tuner front end section consists of a high IP3 mixer whose outputs are common with the FM first mixer.

After going through the first FM IF1 ceramic filter the signal enters the second mixer for conversion to the second IF of 450 kHz where channel selection takes place. The second mixer exhibits a high IP3 value too, and has a fixed gain.

The front end AGC detects mainly a wide band signal (RF signal from the input pins of the first mixer) and a very narrow band signal (Smeter, generated by the signal at the input of the IF2 amplifier after channel selection has occurred). A third fairly narrow band input (IF1 signal from the input pin of the second mixer) is also available, although the first mixer-input-referred IP3 figures of the two mixers make this input generally superfluous. The FE AGC starting points on all three input channels are programmable.

The FE AGC circuit drives the external attenuation P-I-N diodes and the external RF amplifier gain control terminal.

5.2.2 IF NOISE BLANKER

An IF noise blanker circuit is present to detect and remove impulse noise especially at weak field strength levels. The noise spikes are detected at the output of the first mixer and noise cancelling takes place in the second mixer. The necessary delay in the signal path is provided by the IF1 ceramic filter.

The detection circuit consists of an expressly-built IF1 limiter and Smeter detector (not the same used for FM Smeter generation), followed by a pulse detector. The sensitivity of the noise blanker is programmable.

The IF NB is desensitized at high field strength (using the filtered Smeter) and the desensitization threshold can be programmed.

5.2.3 IF AMPLIFIER AND DETECTOR

After channel selection by means of the IF2 ceramic filter, the AM signal is amplified by a very high gain (up to 70 dB, programmable) linear amplifier, and demodulated by an integrated quasi-synchronous detector. The phase information for the detector is derived from the IF2 limiter (shared with the FM signal path) whose input is the IF2 amplifier input pin. The same IF2 limiter is used to generate the AM Smeter information since it uses a narrow band signal and is not subjected to AGC.

The IF2 amplifier gain is controlled by the AGC2 loop.

The IF2 limiter output is also used to generate the input signal for the AM IF counter.

5.2.4 AUDIO OUTPUT

The demodulated signal is buffered on the same output pin used for the FM MPX signal and is subjected to the action of the soft mute circuit as well (programmable threshold/slope). The controlling signal for this function is the filtered Smeter.

5.2.5 STATION DETECTION

Station detection in AM is done evaluating the field strength and the IF2 signal frequency position.

The field strength detector (sensing the filtered Smeter) has a programmable threshold.

The programmability of the IF counter is the same as for the FM IF counter, albeit with different center frequency, frequency window and sampling time programming.

The SD information or the single weak field strength information or IF counter result are available at the SD pin.

The Smeter is available both in analog format (buffered at the SMETER pin) and in a 6 bit digital format (tuner I²C bus read byte).

5.3 TUNING SECTION

5.3.1 VCO AND DIVIDERS

One VCO is used for both AM and FM tuning. To implement the world tuning concept (one VCO application for all the geographical areas), the VCO runs at approximately 200 MHz. Digital dividers generate the LO signals suitable for the AM and FM 1st mixers.

The VCO itself is a two-pin base-input collector-output bipolar amplifier.

A first divider by 1, 2 and 3 is present to generate the FM LO frequency and to be fed to the PLL. A second divider by 4, 6, 8 and 10 is present to generate the AM LO frequency. For FM tuning it is possible to program whether the mixer works in high- or in low-side injection mode. A 90° phase shift circuit operated on the output of the first divider to generate the I and Q portions of the LO for the FM image rejection mixer.

5.3.2 XTAL OSCILLATOR

A 10.25 MHz crystal oscillator is used to generate the reference frequency of the tuning PLL and of the switched capacitor circuits of the TDA7514. The oscillation frequency can be finely adjusted by programming internal capacitors (5 bit).

5.3.3 PLL

Tuning is achieved thanks to a high speed PLL for fast RDS operation. The VCO input (after the first divider) is divided through a swallow counter-divider and compared to the divided 10.25 MHz reference frequency (fully programmable divider).

In FM the absence of a locked condition can be detected in order to automatically enable the charge pump current and loop filter bandwidth to increase in order to speed up the locking process. Automatic switch back to a lower charge pump current and narrower loop filter bandwidth can also be forced by the lock detector, thus achieving a slower but less noisy operation of the tuning loop. Both the high and the low values of the charge pump current are programmable.

Two separate loop filters can be used for optimized AM and FM operation.

5.3.4 STEREO DECODER SECTION

The stereo decoder is crossed by both the AM and the FM signal. The AM signal is only low-pass filtered and subjected to audio noise blanking if necessary; the FM MPX signal is stereo demodulated, low-pass filtered and blanked against impulse noise if necessary.

5.4 FM MODE

5.4.1 INPUT STAGE

The FM stereo decoder input stage provides a high-input impedance buffering. The input impedance is opened during the RDS AF update phase by software or external pin control (programmable function) in order not to discharge the coupling capacitor placed between the tuner output and the stereo decoder input, and so speed up the return to normal listening.

The audio noise blanker circuit is fed from the stereo decoder buffer output: when the input impedance is open during RDS AF update, the noise blanker is still able to work for a short period of time before the capacitance associated with the buffer input stage is discharged.

During RDS AF update the output of the buffer is muted to avoid letting transient signals leak through the audio processor section.

An additional input series switch has been added to perform the stereo decoder auto zero function (see also Audio Processor section). This switch must be opened before selecting the tuner as the audio source in order to allow the stereo decoder internal filters to discharge before the offset measurement is performed.

The input buffer in FM mode is followed by an 80 kHz low-pass filter to remove high frequency noise.

5.4.2 PLL

The buffered MPX signal is fed to a 19 kHz-centered band-pass filter and subsequently to a PLL used to regenerate the 38 kHz carrier for stereo demodulation.

The PLL compares the pilot tone with the divided output frequency of an internal VCO running at 456 kHz, locking its operating frequency and phase to that of the pilot tone. The PLL status can be stored during the RDS AF update phase in order to speed up subsequent returning to normal listening conditions.

Since the VCO tuning range is small, the VCO needs being adjusted to a setting that ensures lock is achieved when a pilot tone is present. On the current TDA7514 version it is necessary to perform this alignment during the car-radio test phase, by injecting a 19 kHz tone into the stereo decoder and changing the VCO programming until a lock condition is reached.

The presence of a stereo signal is detected in this block by measuring the peak value of the pilot tone and comparing it with a programmable threshold. The resulting information can be read back via I²C bus (audio processor/stereo decoder I²C read byte).

5.4.3 STEREO DEMODULATOR AND BLEND

The MPX signal is fed to the stereo demodulator where the L and R outputs are derived. In case of a stereo transmission in weak field or bad reception conditions (see FM tuner quality section) a gradual transition

from stereo to mono is performed. The signal strength thresholds for the automatic stereo blend functions can be set by programming the gain of the Smeter contribution to the SNC signal (compared to a fixed threshold sets the full stereo point) and subsequently programming the voltage threshold against which the SNC signal is compared to set the full mono threshold.

In case the transmission is stereo, it is possible if so desired to set it to forced mono to improve the received SNR.

The TDA7514 stereo demodulator additionally performs the functions of roll-off compensation and pilot cancelling. The amount of the former is programmable. The latter function is activated when an FM MPX signal with pilot tone is detected; the function is disabled in AM and in FM if no pilot tone is detected.

5.4.4 HIGH CUT AND DE-EMPHASIS FILTERS

The L and R signals are low-passed filtered by the high cut and, subsequently, by the de-emphasis filter.

The high cut filter consists of a fixed resistor and a 5 bit digitally-controlled binary-weighted capacitor (whose value therefore changes between C_{min} and $C_{min} + 32 \times C_{step}$). The digital control is done by converting the filtered Smeter into a 5 bit word. Programming the internal resistor value, three possible corner frequency ranges (800 Hz - 4 kHz, 2 kHz - 10 kHz, 4 kHz - 20 kHz) are available. It is possible to force the actual range to be smaller than one of the above mentioned ones by setting:

- the maximum capacitor value (4 position programmable control);
- a 5 bit word to be used as limit (32 possible values), in conjunction with a bit that sets whether this limit is to be used as a maximum or as a minimum;
- it is additionally possible, if so desired, to keep the high cut filter to a fixed position by sending the position code in the previously mentioned 5 bit register and further setting a dedicated bit;
- the high cut filter can also be defeated via a dedicated bit.

The controlling signal for this filter is chiefly the filtered Smeter. It is also possible to program the high cut control input selector to use the SNC instead of the Smeter. The contributions to the SNC signal from the Smeter, adjacent channel and multipath detectors is the same as for the stereo blend function. The level "0" of the converted signal (corresponding to the maximum filter corner frequency) is obtained when the control signal is equal to or greater than the programmable threshold VHCCCH. The level "31" (corresponding to the minimum filter corner frequency) is obtained when the control signal is equal to or smaller than the programmable threshold VHCCL. Noise blanking is performed at this stage. "Corners" in the waveform due to the holding action of the noise blanking circuit are smoothed by the successive de-emphasis filter.

The fixed de-emphasis filter can be programmed to 75 us and 50 us; in AM mode it is shifted to a seven times higher corner frequency.

5.4.5 AM MODE

In AM mode the PLL is on though no pilot tone is present; the stereo demodulator is forced to work in the mono configuration and the pilot canceller is off.

5.4.6 INPUT STAGE

The only difference between the AM and the FM configuration of the input stage lies in the input impedance only (30 kOhm for AM, 100 kOhm for FM). The functions are identical.

5.4.7 DELAY FILTER

The input stage is followed by a fourth order low-pass filter with a cut-off frequency of approximately 4 kHz and a delay of approximately 130 us whose main purpose is to generate the delay in the signal path necessary for audio noise blanking. The filter contributes to the low-pass filtering of the AM signal as well.

5.4.8 HIGH CUT FILTER

The high cut filter in AM can be used both statically by programming a fixed corner frequency (the 800 Hz

- 4 kHz range has been specifically designed for AM although it is available also in FM) or dynamically, exactly like the FM high cut filter. See the FM high cut filter section for further details.

The de-emphasis filter is shifted to a seven times higher corner frequency in AM mode with respect to the FM mode.

5.4.9 AUDIO NOISE BLANKER SECTION

The operation of the audio noise blanker varies in FM and in AM.

5.4.10 FM MODE

The FM noise blanker triggering circuit acts as a peak-to-average detector on the high-passed MPX signal. The input 140 kHz high-pass filter removes the desired audio part so that the impulse noise is more easily detected. The high-pass signal then follows two different paths:

- after rectification it is fed to one terminal of the trigger comparator; the impulse noise is present on this path together with high frequency noise;
- after rectification it is fed to a slow peak detector which is not able to follow the impulse noise but whose output (PEAK signal) represents the white high frequency noise level; the output of the slow rectifier is the main input of the threshold generation circuit, whose output is applied to the second terminal of the trigger comparator.

The threshold generation circuit generates a threshold as a monotonically increasing function of the PEAK signal. The function can be programmed in its linear coefficient and in its second order coefficient.

For superior performance in the dynamically changing car-radio environment the activation threshold is further influenced by three other parameters: field strength, FM frequency deviation and multipath presence.

The influence of these parameters can be disabled and is programmable. The parameter influence on the noise blanker sensitivity is as follows:

- field strength: when the field strength decreases the noise blanker less becomes less sensitive (at low field strength white noise becomes higher and false triggering becomes more likely);
- frequency deviation: if the FM frequency deviation is high, the noise blanker becomes less sensitive; this is due to the fact that a large deviation causes a high MPX level which in turn might not be rejected enough by the noise blanker detector input high-pass filter, thus causing false triggering;
- multipath: the presence of a strong multipath condition increases the sensitivity of the noise blanker.

The triggering comparator output activates a retriggerable monostable circuit whose output drives the "Hold" switch in the high cut filter section. The blanking time is programmable and the whole noise blanker action is defeatable via software.

5.4.11 AM MODE

In AM mode the noise blanker detector can operate in two different ways. For both modes the possibility to low-pass the signal entering the noise blanker detector is foreseen (7.2 kHz LP filter software defeatable), in order to be able to reduce the white noise effect on the detector that may lead to false triggering, especially for AM mode 1.

5.4.12 AM MODE 1

This noise blanker operation mode is similar to the FM operation mode. The input audio signal taken before the delay filter (see stereo decoder in AM) can be low-pass filtered (see AM mode description above) and is subsequently high-pass filtered with a filter programmable in terms of corner frequency and order.

The resulting signal still contains the impulse noise information, high frequency noise (depending on the activation of the 7.2 kHz filter) and audio (it is not possible to effectively eliminate all the audio content because the AM channel bandwidth - determined by the IF2 ceramic filter - is barely wider than the signal bandwidth, and the spectral differences between the impulse noise and the signal are small).

The signal is then applied to the same peak-to-average detector that is used for FM; the difference is that the deviation detector is not influencing the threshold generation in this case. The noise blanking time, programmable also for AM, is about 30 times longer than for FM.

5.4.13 AM MODE 2

In this operation mode the detector operates in a much more straightforward configuration: the instantaneous AM audio level is compared with a fixed programmable threshold, and the comparison result activates the retriggerable monostable. The advised programmed threshold corresponds to an equivalent 140% AM modulation level.

5.5 AUDIO PROCESSOR SECTION

5.5.1 INPUTS

The audio processor input section features a main channel multiplexer, a rear channel multiplexer (RSA, Rear Seat Audio function), an input gain stage and autozero circuit.

The main channel multiplexer allows connecting the following sources to the main audio processing path:

- 1 quasi-differential source;
- 1 stereo differential source;
- 1 mono differential source;
- tuner output (AM, FM);
- beep generator.

The RSA selector (see speaker output section) can connect the rear speaker outputs to the following sources bypassing all the tone and volume control:

- 1 quasi-differential source;
- 1 stereo differential source;
- tuner output (AM, FM).

The different sources are subjected to the following input attenuations:

- quasi-differential source: -4 dB
- stereo differential source: 0 dB
- mono differential source: -4 dB.

The main channel signal path features an input gain stage (0..+15 dB, 1 dB step) to equalize the different source levels and the autozero circuitry that removes the DC offset generated between the input pins and the input gain stage output.

The autozero procedure is automatically run every time byte 0 of the audio processor I²C software is addresses, that is every time the main source is changed or the input gain is changed. In case the new source is the stereo decoder the source change must be preceded by opening the stereo decoder input for a time long enough to discharge the stereo decoder internal filters (see stereo decoder input section). The same is true even when the source is switched from AM to FM and vice-versa. The autozero procedure can be manually activated through a dedicated bit, and can be prevented from running by setting a different dedicated bit. The beep generator is considered a main channel source, and it can generate a 500 Hz, 1 kHz, 2 kHz, 3 kHz tone.

5.5.2 SOFT MUTE

The input stage is followed by a soft mute stage aimed at automatically and smoothly driving the audio processor from its current state into a full mute condition. The overall transition time is software selectable.

It is possible to control the stereo decoder RDS AF update mute circuits (input impedance open switch ("high ohmic mute"), stereo decoder mute and PLL hold) from the audio processor soft mute.

5.5.3 LOUDNESS FILTER

The TDA7514 features a loudness function made up by a 20 dB attenuator in 1 dB steps, a second order LP filter with programmable corner frequency and a defeatable high pass filter with programmable corner frequency.

The attenuator has been realized employing the "soft step" technique that reduces the audible DC click at the speaker outputs by dividing the 1 dB step into several smaller-amplitude, longer duration transitions.

5.5.4 VOLUME CONTROL

The volume stage controls the level over a +15 dB..-79 dB + mute range in 1 dB steps. The volume attenuator is also realized with the soft step circuitry.

5.5.5 TREBLE FILTER

The treble filter consists of a second order resonating filter with programmable center frequency. The boost/cut range is !15 dB in 1 dB steps.

5.5.6 BASS FILTER

The bass filter consists of a second order resonating filter with programmable center frequency and quality factor. It is also possible to set and defeat the DC mode both in cut and in boost. The boost/cut range is !15 dB in 1 dB steps and the attenuator features the soft step circuitry.

www.DataSheet4U.com

5.5.7 SPEAKER ATTENUATORS

The speaker attenuator driver circuit allows separate volume control for each of the four outputs. The level is controlled over a +15 dB.. -79 dB + mute range in 1 dB steps with soft step.

An output buffer provides DC shift to a typical 4V level and an AC gain of +4 dB.

The source of each speaker output circuit can be chose among the following configurations:

- tone control output via external AC coupling (coupling shared by front and rear channels);
- tone control output via internal DC coupling (coupling shared by front and rear channels);
- rear seat audio (only for rear channels).

It is furthermore possible to mix an external source (typically the chime source) on all the four outputs, selecting on which outputs the mixing must take place (any combination is allowed). The volume of the mixing source cannot be changed internally.

Table 75. TQFP80 Mechanical Data & Package Dimensions

DIM.	mm			inch		
	MIN.	TYP.	MAX.	MIN.	TYP.	MAX.
A			1.60			0.063
A1	0.05		0.15	0.002		0.006
A2	1.35	1.40	1.45	0.053	0.055	0.057
B	0.22	0.32	0.38	0.009	0.013	0.015
C	0.09		0.20	0.003		0.008
D		16.00			0.630	
D1		14.00			0.551	
D3		12.35			0.295	
e		0.65			0.0256	
E		16.00			0.630	
E1		14.00			0.551	
E3		12.35			0.486	
L	0.45	0.60	0.75	0.018	0.024	0.030
L1		1.00			0.0393	
K	3.5°(min.), 7°(max.)					

OUTLINE AND MECHANICAL DATA

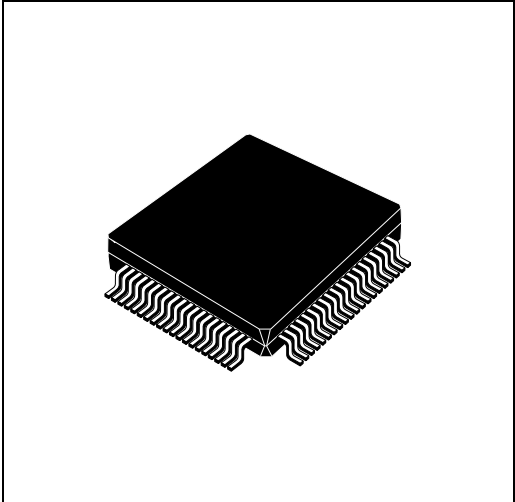

**TQFP80
(14x14x1.40mm)**

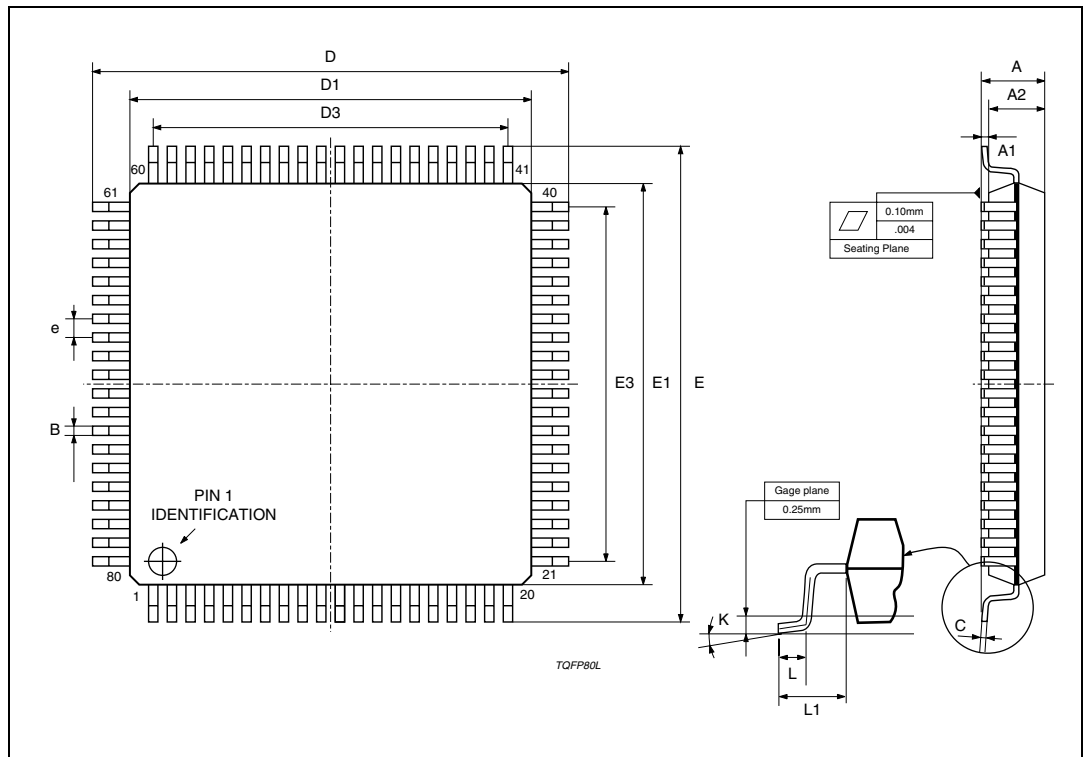

Table 76. Revision History

Date	Revision	Description of Changes
June 2005	1	First Issue

Information furnished is believed to be accurate and reliable. However, STMicroelectronics assumes no responsibility for the consequences of use of such information nor for any infringement of patents or other rights of third parties which may result from its use. No license is granted by implication or otherwise under any patent or patent rights of STMicroelectronics. Specifications mentioned in this publication are subject to change without notice. This publication supersedes and replaces all information previously supplied. STMicroelectronics products are not authorized for use as critical components in life support devices or systems without express written approval of STMicroelectronics.

The ST logo is a registered trademark of STMicroelectronics.
All other names are the property of their respective owners

© 2005 STMicroelectronics - All rights reserved

STMicroelectronics group of companies

Australia - Belgium - Brazil - Canada - China - Czech Republic - Finland - France - Germany - Hong Kong - India - Israel - Italy - Japan -
Malaysia - Malta - Morocco - Singapore - Spain - Sweden - Switzerland - United Kingdom - United States of America

www.st.com