

Pyroelectric Infrared Sensors & Sensor Modules

PYROELECTRIC
INFRARED
SENSORS
&
SENSOR
MODULES

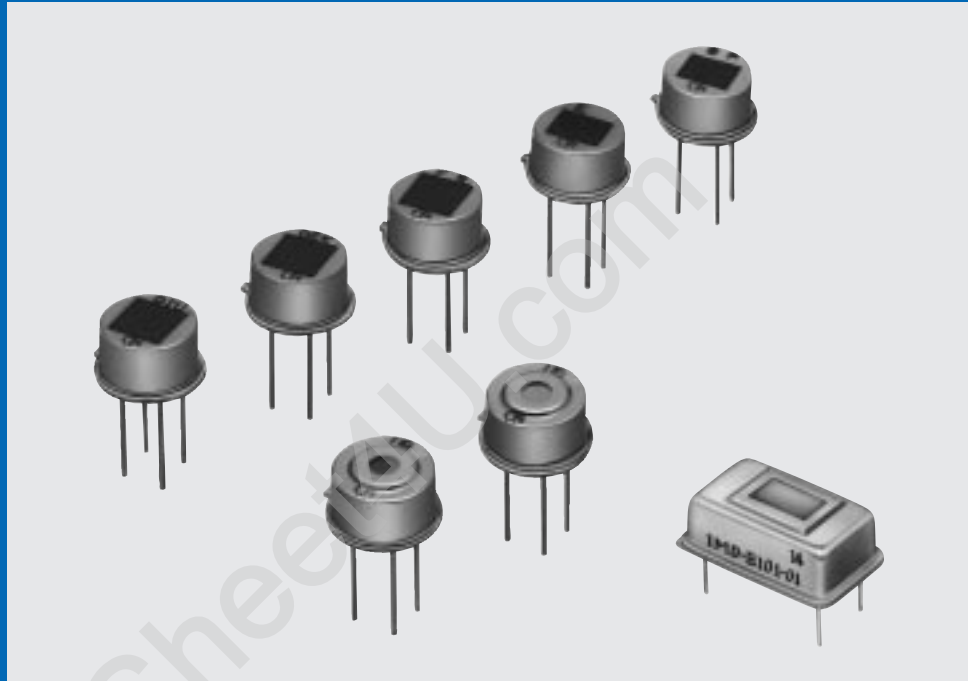

Murata
Manufacturing Co., Ltd.

Cat.No.S21E-3

www.DataSheet4U.com

CONTENTS

Part Numbering	1
1 Dual Type Pyroelectric Infrared Sensor IRA-E700 Series	2
2 Quad Type Pyroelectric Infrared Sensor IRA-E900 Series	3
3 Quad Type Pyroelectric Infrared Sensor IRA-E940ST1 Series	4
4 Temperature Compensation Single Type Pyroelectric Infrared Sensor IRA-E420 Series	5
Pyroelectric Infrared Sensor IRA Series Characteristics Data	6
5 Pyroelectric Infrared Sensor Module IMD Series	11
Notice	13

● Part Numbering

Pyroelectric Infrared Sensor

(Global Part Number)

IR	A-	E710ST	1
①	②	③	④

- ① Product ID
- ② Type
- ③ Characteristics
- ④ Individual Specification Code

* Global Part Number shows only an example which might be different from actual part number.

* "③ Characteristics" and "④ Individual Specification Code" might have different digit number from actual Global Part Number.

Sensor Module

(Global Part Number)

IM	D-	B101-	01
①	②	③	④

- ① Product ID
- ② Type
- ③ Characteristics
- ④ Individual Specification Code

* Global Part Number shows only an example which might be different from actual part number.

* "③ Characteristics" and "④ Individual Specification Code" might have different digit number from actual Global Part Number.

Pyroelectric Infrared Sensors



Dual Type Pyroelectric Infrared Sensor IRA-E700 Series

Pyroelectric infrared sensors, IRA series, exhibit high sensitivity and reliable performance made possible by Murata's ceramic technology and Hybrid IC technique expertise developed over many years. IRA-E700 series realizes cost benefits and higher performance with a new infrared sensor element of improved material parameters and fabrication. IRA-E700 series is available in two types. IRA-E710ST0 has enhanced immunity to RFI (Radio Frequency Interference).

■ Features

1. High sensitivity and excellent S/N ratio
2. High stability to the temperature change
3. Slight movement can be detectable.
4. High immunity to the external noise (Vibration, RFI etc.)
5. Custom design is available.
6. Higher in cost-performance

■ Applications

1. Security
2. Lighting appliances
3. Household or other appliances

■ Rating (25°C)

Part Number	IRA-E700ST0	IRA-E710ST0
Responsivity (500K, 1Hz, 1Hz)	4.3mV _{pp} (Typ.)	
Field of View	$\theta_1 = \theta_2 = 45^\circ$	
Optical Filter	5μm long-pass	
Electrode	(2.0×1.0mm)×2	
Supply Voltage	2 to 15V	
Operating Temperature	-40 to 70°C	
Storage Temperature	-40 to 85°C	

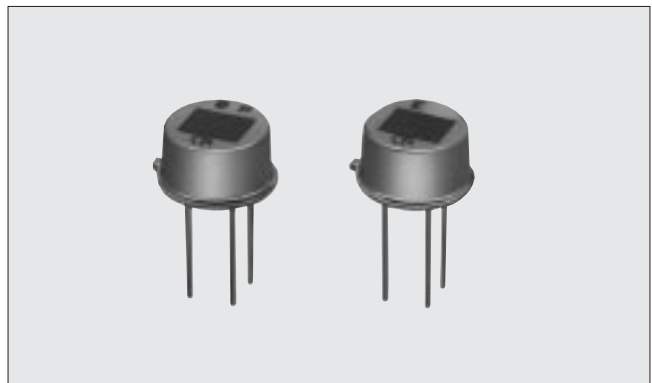

■ Dimensions & Circuit Diagrams

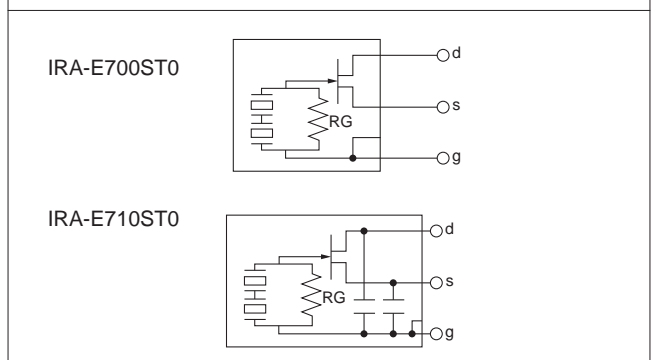
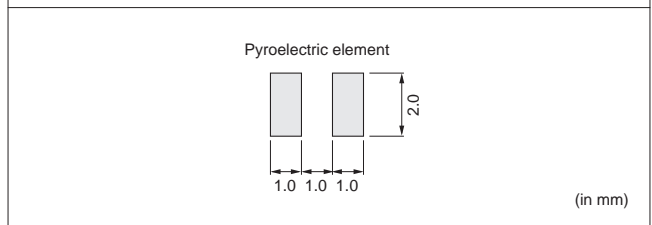
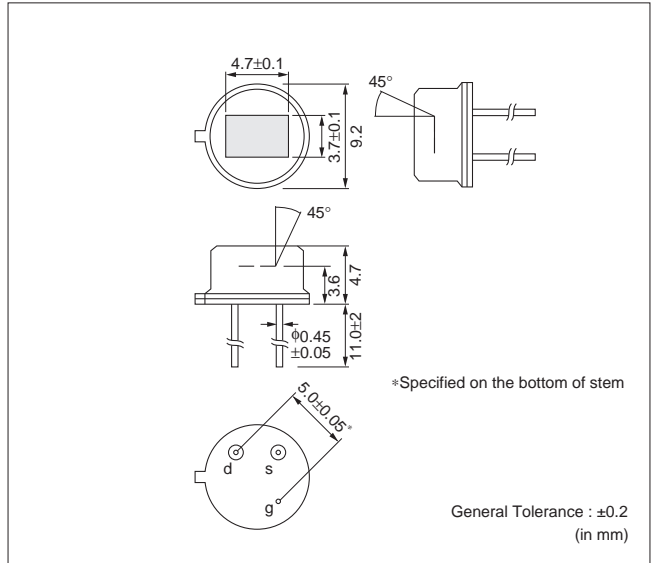

Pyroelectric Infrared Sensors



Quad Type Pyroelectric Infrared Sensor IRA-E900 Series

Pyroelectric infrared sensors, IRA series, exhibit high sensitivity and reliable performance made possible by Murata's ceramic technology and Hybrid IC technique expertise developed over many years. IRA-E900 series realizes cost benefits and higher performance with a new infrared sensor element of improved material parameters and fabrication. IRA-E900 series is available in two types. IRA-E910ST1 has enhanced immunity to RFI (Radio Frequency Interference).

■ Features

1. High sensitivity and excellent S/N ratio
2. High stability to the temperature change
3. Slight movement can be detectable.
4. Non directional sensing with wide F.O.V.
5. High immunity to the external noise (Vibration, RFI etc.)
6. Custom design is available.
7. Higher in cost-performance

■ Applications

1. Security
2. Lighting appliances
3. Household or other appliances

■ Rating (25°C)

Part Number	IRA-E900ST1	IRA-E910ST1
Responsivity (500K, 1Hz, 1Hz)	3.3mV _{pp} (Typ.)	
Field of View	$\theta_1 = \theta_2 = 41^\circ$	
Optical Filter	5μm long-pass	
Electrode	(1.1×1.1mm)×4	
Supply Voltage	3 to 15V	
Operating Temperature	-25 to 55°C	
Storage Temperature	-40 to 85°C	

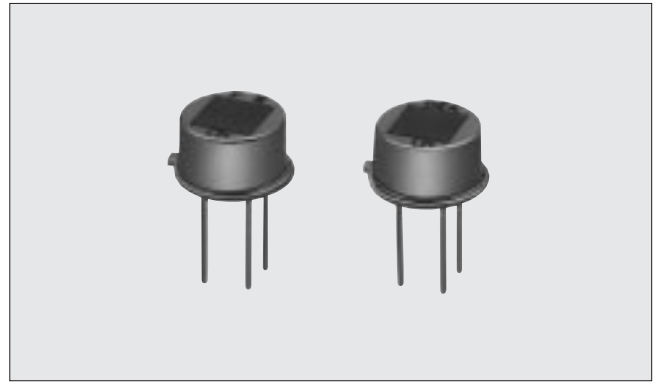

■ Dimensions & Circuit Diagrams

Technical drawings showing dimensions and circuit diagrams for IRA-E900ST1 and IRA-E910ST1 sensors.

Dimensions (in mm):

- Top view: 4.7±0.1 (width), 9.2 (height)
- Side view: 41° (view angle), 4.7 (total height), 3.6 (height to top of stem), 0.45±0.05 (stem diameter), 11.0±0.2 (total length)
- Bottom view: 5.08±0.05 (width), 9 (width to center), d, s, g (pin locations)
- Pyroelectric element: 1.1 (width), 1.1 (height), 1.1 (width), 1.1 (height)

General Tolerance : ±0.2 (in mm)

*Specified on the bottom of stem

Circuit Diagrams:

- IRA-E900ST1: Shows a pyroelectric element connected to a resistor (RG) and a transistor circuit. Pins are labeled d, s, and g.
- IRA-E910ST1: Shows a pyroelectric element connected to a resistor (RG) and a transistor circuit with a capacitor. Pins are labeled d, s, and g.

Pyroelectric Infrared Sensors



Quad Type Pyroelectric Infrared Sensor IRA-E940ST1 Series

3

Pyroelectric infrared sensors, IRA series, exhibit high sensitivity and reliable performance made possible by Murata's ceramic technology and Hybrid IC technique expertise developed over many years. IRA-E940ST1 realizes cost benefits and higher performance with a new infrared sensor element of improved material parameters and fabrication. IRA-E940ST1 which has quad elements and 2 outputs will detect the human body more correctly with OR/AND logic circuit.

■ Features

1. High sensitivity and excellent S/N ratio
2. High stability to the temperature change
3. High immunity to the external noise (Vibration, RFI etc.)
4. Higher in cost-performance
5. Custom design is available.

■ Applications

1. Security
2. Lighting appliances
3. Household or other appliances

■ Rating (25°C)

Part Number	IRA-E940ST1
Responsivity (500K, 1Hz, 1Hz)	3.3mV _{pp} (Typ.)
Field of View	$\theta_1=55^\circ, \theta_2=50^\circ$
Optical Filter	5 μ m long-pass
Electrode	(1.35X1.0mm)X4
Supply Voltage	2 to 15V
Operating Temperature	-25 to 55°C
Storage Temperature	-40 to 85°C

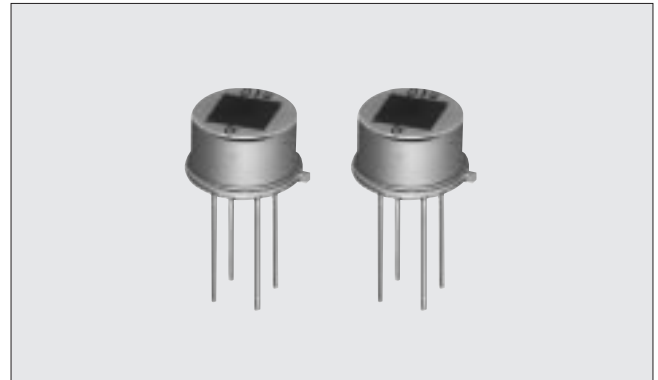

■ Dimensions & Circuit Diagrams

General Tolerance : ± 0.2 (in mm)

Pyroelectric element

Pyroelectric Infrared Sensors



Temperature Compensation Single Type Pyroelectric Infrared Sensor IRA-E420 Series

Single type pyroelectric infrared sensors IRA-E420 series, have a temperature compensation element. They are suitable for flame detection and gas detection.

■ Features

1. High stability against abrupt ambient temperature change
2. High immunity to the external noise (Vibration, RFI etc.)
3. Custom design is available with varying optical filter.

■ Applications

Part Number	Optical Filter	Applications
IRA-E420S1	Silicon	1-15μm infrared detection
IRA-E420QW1	4.3μm band-pass	Flame detection

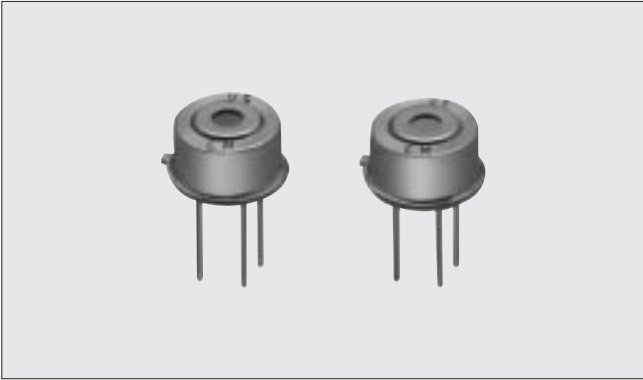

4

■ Dimensions & Circuit Diagrams

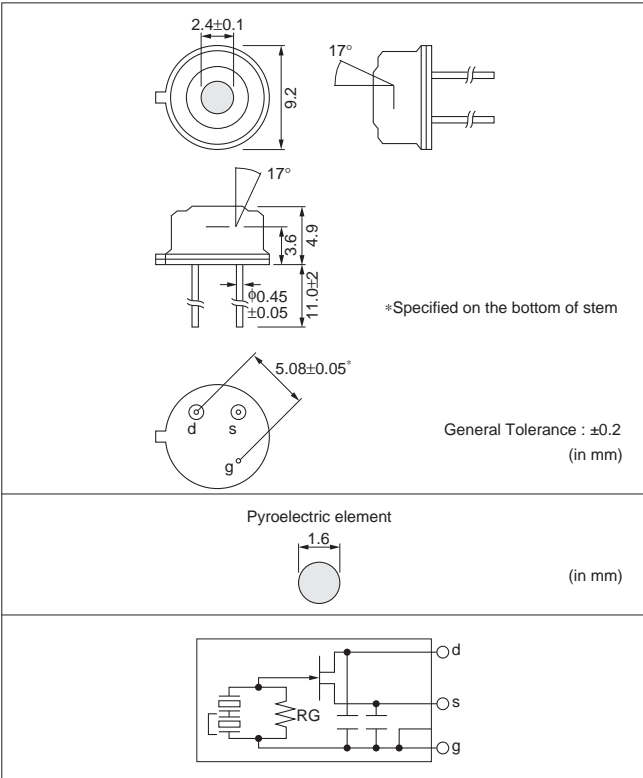

■ Rating (25°C)

Part Number	IRA-E420S1	IRA-E420QW1
Responsivity (500K, 1Hz, 1Hz)	3.4mV _{pp} (Typ.)	1.3mV _{pp} (Typ.)*
Field of View	$\theta_1 = \theta_2 = 17^\circ$	
Optical Filter	Silicon	4.3μm band-pass
Electrode	φ1.6mm	
Supply Voltage	3 to 15V	
Operating Temperature	-25 to 70°C	-25 to 55°C
Storage Temperature	-30 to 100°C	

* 700K, 5Hz, 1Hz

Pyroelectric Infrared Sensor IRA Series Characteristics Data

■ Spectral Response of Window Materials

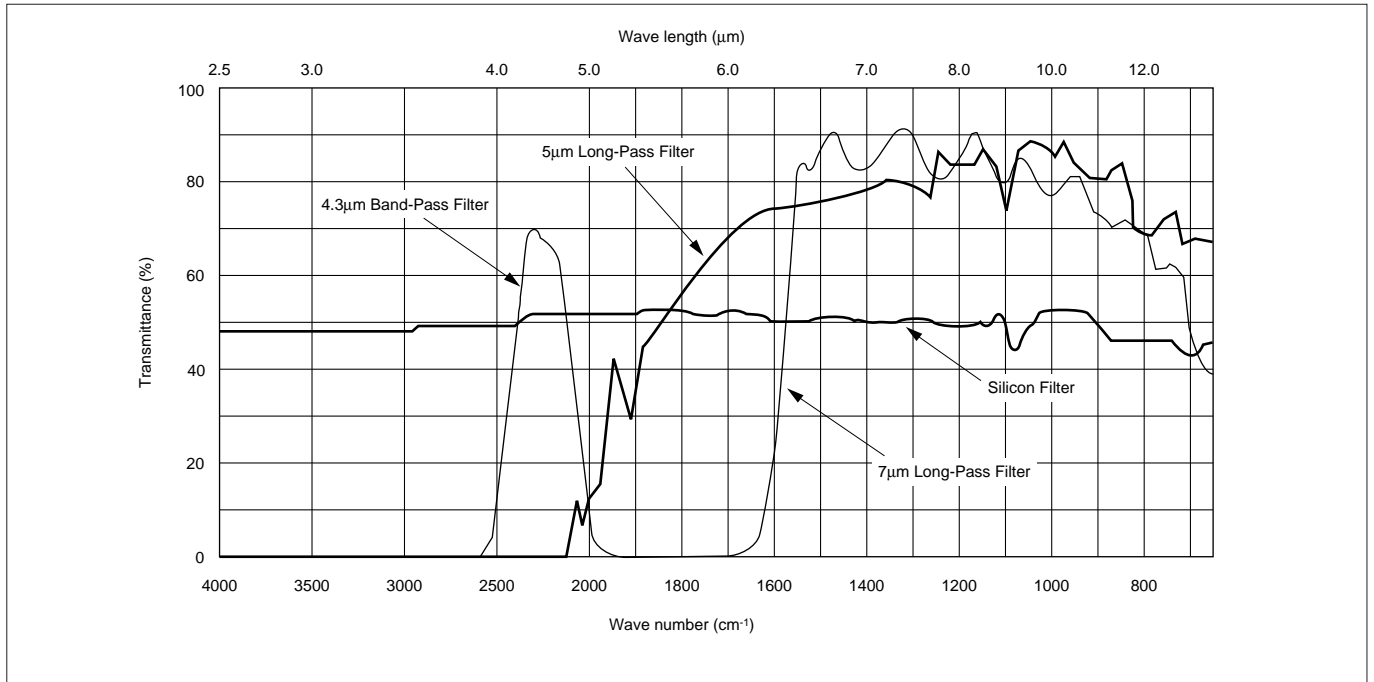

4

■ Frequency Characteristics

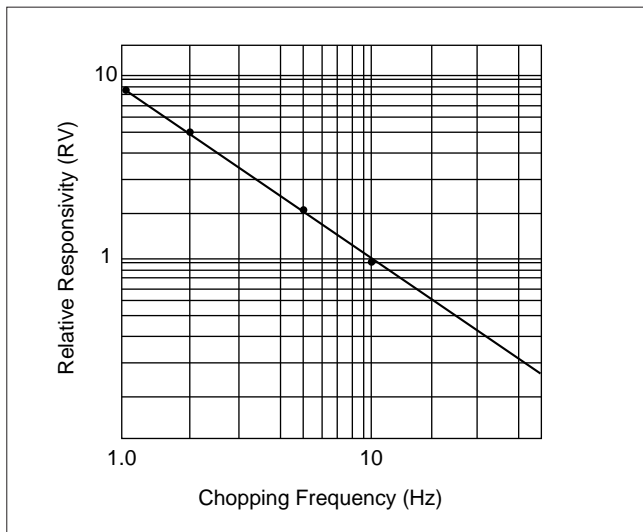

Pyroelectric Infrared Sensor IRA Series Characteristics Data

■ Fresnel Lens for Human Body Detection

PPGI0601

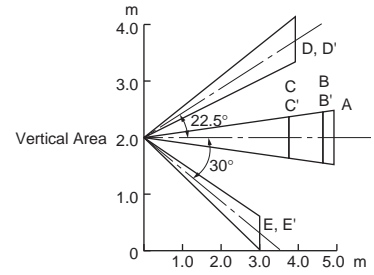
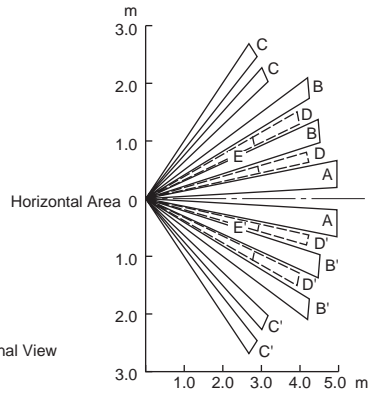
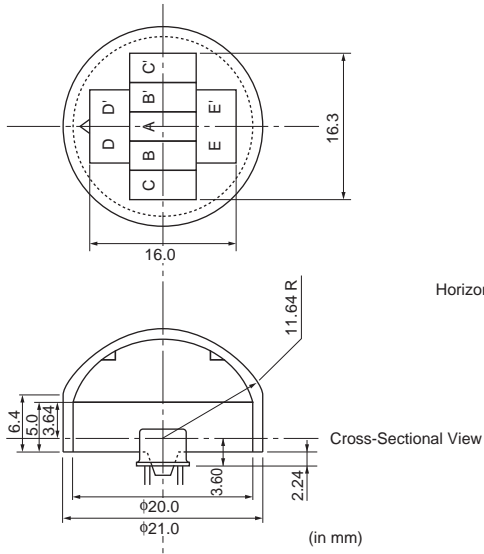

PPGI0902

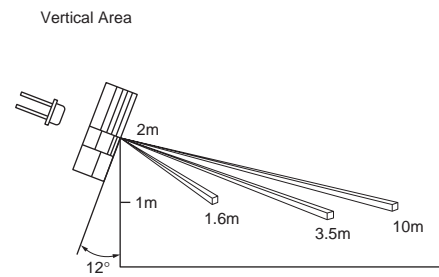
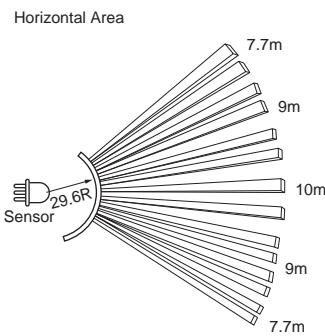
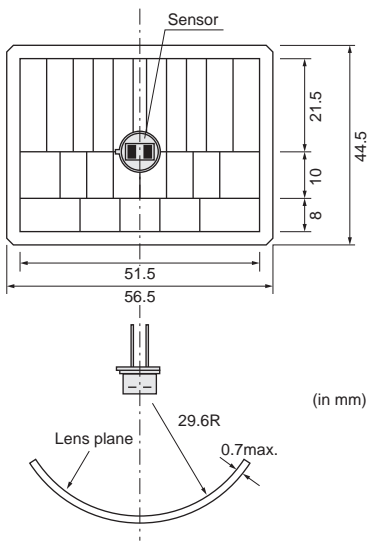

Pyroelectric Infrared Sensor IRA Series Characteristics Data

PPGI0626

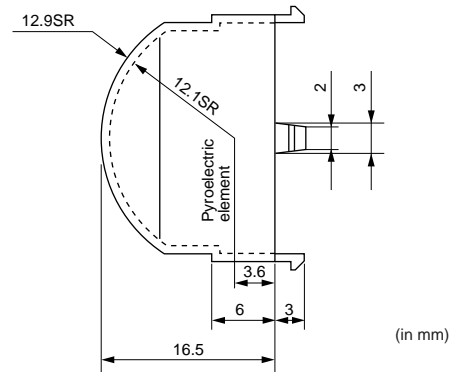
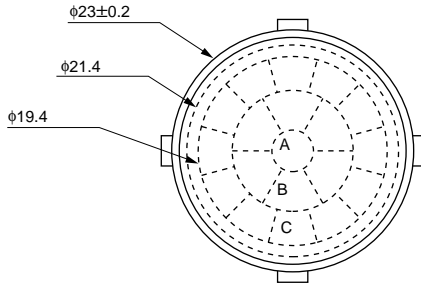

Detection area on the floor

B : 60°pitch
C : 30°pitch

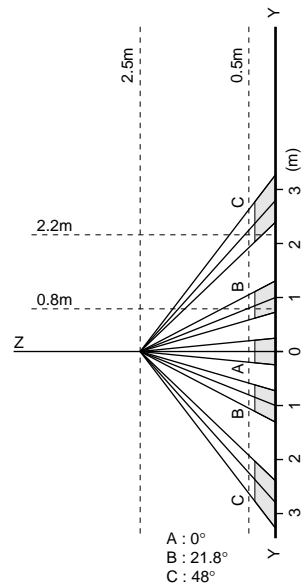
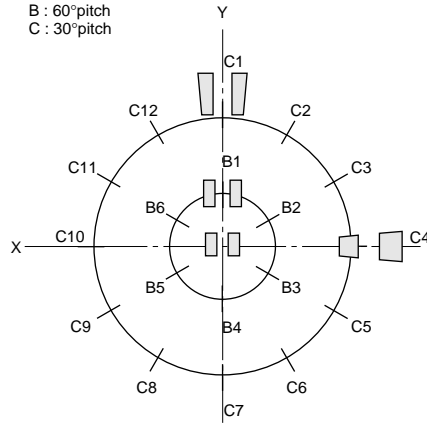

A : 0°
B : 21.8°
C : 48°

Freshel lens are available upon request.

Pyroelectric Infrared Sensor IRA Series Characteristics Data

■ Reliability Test

IRA-E700 series, IRA-E900 series

Item	Test Conditions	Criteria	
High Temperature	100°C for 500 hrs.	After test completion, leave for three hours in normal humidity temperature conditions, and then measure. 1. External appearance: No significant damage. 2. Sensitivity: Tolerance within 20% deviation from original value. 3. Noise: Maximum tolerance +100mV of original value	
Low Temperature	-40°C for 500 hrs.		
Humidity	60°C, 95% RH for 500 hrs.		
Heat Cycle	20 times of following cycle. -25°C, 30min.↔Room temp., 30min.↕ ↑Room temp., 30min.↔55°C, 30min.		
Vibration	Apply vibration of amplitude of 1.5mm with 10 to 55Hz band to each of 3 perpendicular directions for 60min.		
Shock	Apply shock of 100G sinewave by standard shock tester to each of 3 perpendicular directions.		
Soldering Heat	Immerse up to 3.0mm from can case in solder bath of 260±5°C for 10±1 s.		
Hermetic Sealing	Conform to MIL-STD-202F chapter 112D, condition D. Immerse in fluorocarbon bath (FC-40) of 125±5°C for 20 s.		No generation of bubbles.
Solderability	Conform to MIL-STD-202F chapter 208B. Immerse in rosin flux and Immerse up to 2.0 to 2.5mm from can case in solder bath of 230±5°C for 5±0.5 s.		More than 95% of the terminal should be covered by solder.

IRA-E420 series

Item	Test Conditions	Criteria	
High Temperature	100°C for 500 hrs.	After test completion, leave for three hours in normal humidity temperature conditions, and then measure. 1. External appearance: No significant damage. 2. Sensitivity: Tolerance within 20% deviation from original value. 3. Noise: Maximum tolerance +100mV of original value	
Low Temperature	-30°C for 500 hrs.		
Humidity	60°C, 95% RH for 500 hrs.		
Heat Cycle	20 times of following cycle. -25°C, 30min.↔Room temp., 30min.↕ ↑Room temp., 30min.↔55°C, 30min.		
Vibration	Apply vibration of amplitude of 1.5mm with 10 to 55Hz band to each of 3 perpendicular directions for 60min.		
Shock	Apply shock of 100G sinewave by standard shock tester to each of 3 perpendicular directions.		
Soldering Heat	Immerse up to 3.0mm from can case in solder bath of 260±5°C for 10±1 s.		
Hermetic Sealing	Conform to MIL-STD-202F chapter 112D, condition D. Immerse in fluorocarbon bath (FC-40) of 125±5°C for 20 s.		No generation of bubbles.
Solderability	Conform to MIL-STD-202F chapter 208B. Immerse in rosin flux and Immerse up to 2.0 to 2.5mm from can case in solder bath of 230±5°C for 5±0.5 s.		More than 95% of the terminal should be covered by solder.

Pyroelectric Infrared Sensor Modules



Pyroelectric Infrared Sensor Module **IMD** Series

Newly Developed Modules with Lower Power Consumption and Extra Features.

The IMD Series is comprised of an amplifier and high performance infrared sensor modules in compact, hermetically sealed metal can packages. Power consumption of the module is very low and a Fresnel lens is included in the module. Analog & Digital Output Model (IMD-B101-01) and Digital Output & Brightness Sensor (CdS) Input Model (IMD-B102-01) are available for different applications.

■ Features

1. With the fresnel lens, the sensor is able to detect the human body at a distance of 5m through angles of 119°×38° (Max.)
2. The modules have a compact size of 20.3×12.6×7.8mm.
3. The modules incorporate an amplifier and a single processing circuit.
4. They have outstanding reliability and EMI characteristics.
5. They have low power consumption.

■ Applications

1. Automatic light switches
2. On/off controls for household appliances, industrial equipment and office equipment
3. Amusement devices (Games, Toys, etc.)

■ Block Diagram

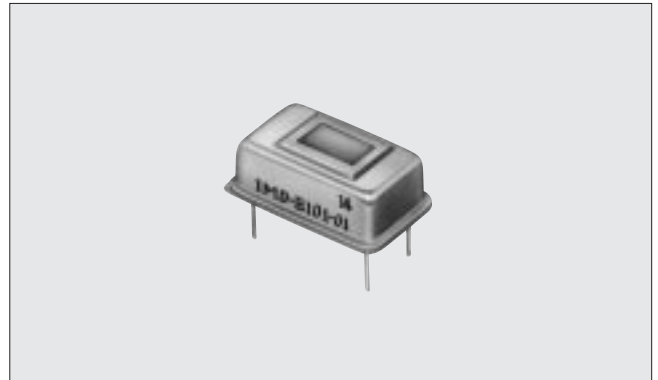
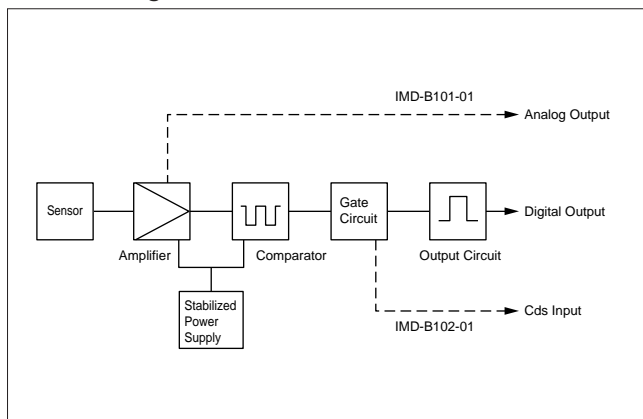

■ Dimensions

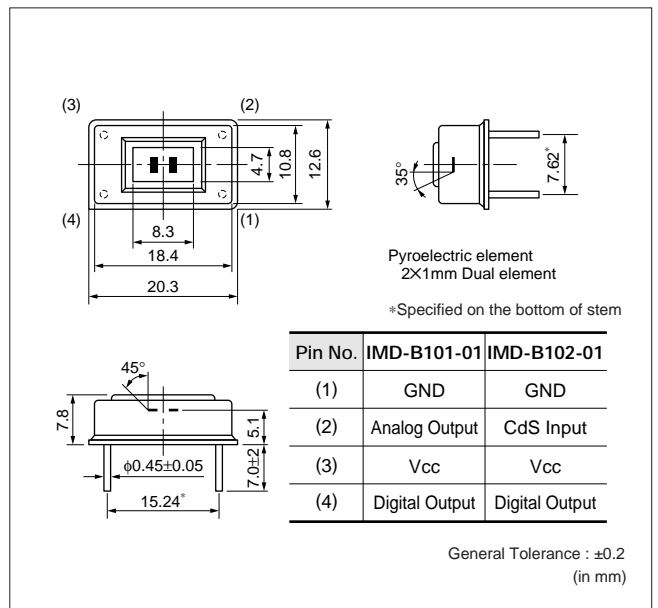

■ Fresnel Lens

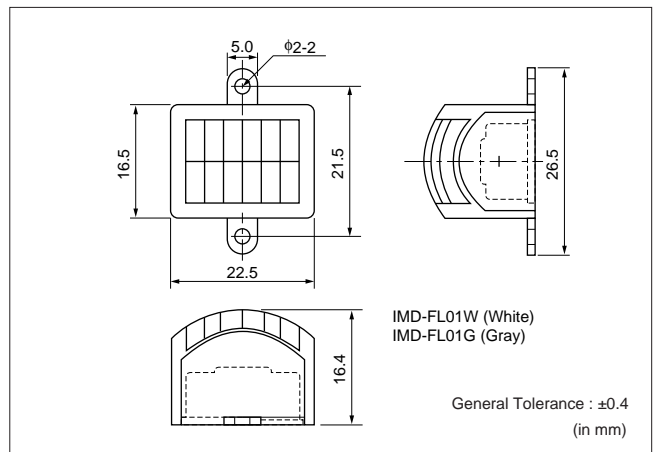

Pyroelectric Infrared Sensor Module IMD Series

Max. Rating (25°C)

Max. Supply Voltage	5.5V
Operating Temp. Range	-10 to +50°C (Without condensation)
Storage Temp. Range	-20 to +60°C

Rating (25°C)

Items		
Supply Voltage		2.6–5.5V
Current Consumption	Ready Period	30–60μA
	Active Period	50–120μA
Output Terminal		C-MOS
Output Current		1mA
Output Pulse Width (P1)		1.0–3.0s
Prohibited Time (P2)		<3.0s
Wave Length Range		5–14μm
Detection Length	Without Lens	1m
	With IMD-FL01W/G	5m
Detection Range		119°×38° (Max.)

Timing Chart (IMD-B101-01)

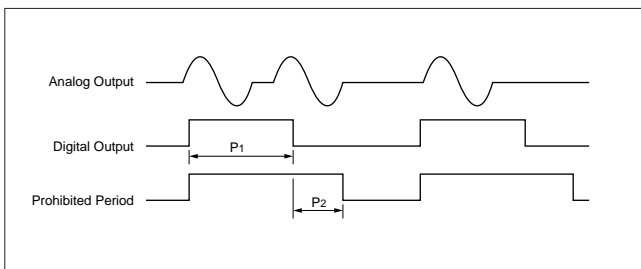

Detection Area (With Fresnel Lens)

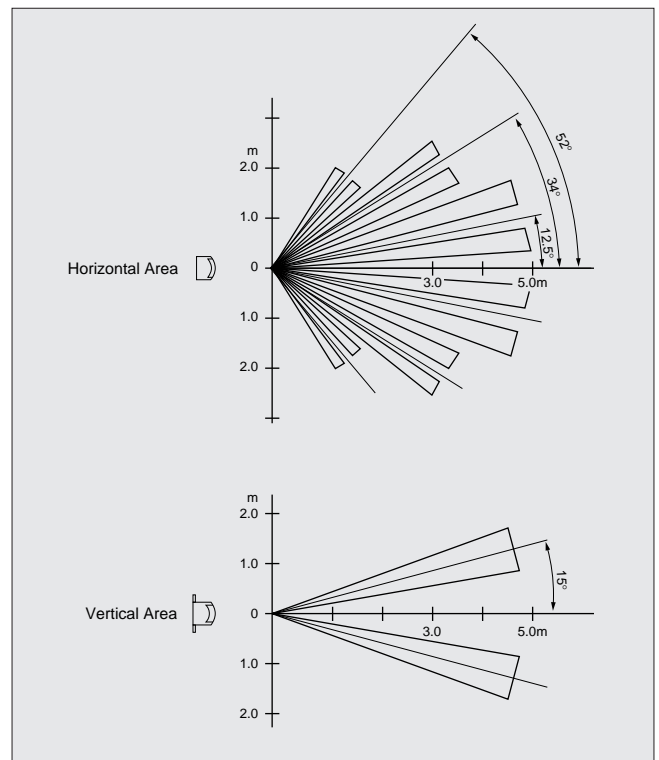

Typical Application (IMD-B102-01)

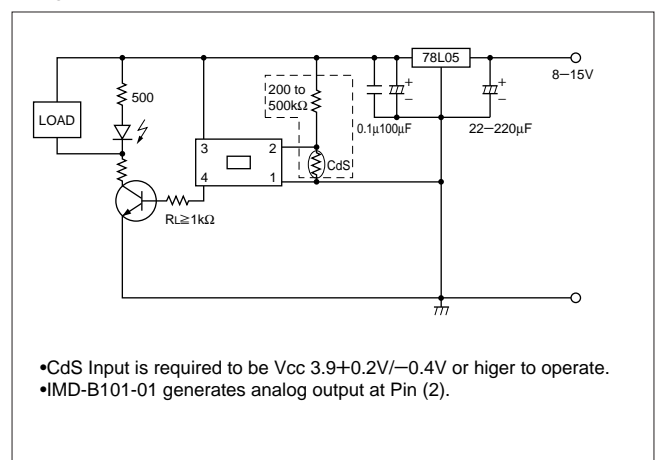

Reliability Test

Item	Test Conditions	Criteria
High Temperature	60°C for 500 hrs.	After test completion, leave for three hours in normal humidity temperature conditions, and then measure. 1. External appearance: No significant damage. 2. Sensitivity: Min. 70% of original value. 3. Current consumption: Within rated value.
Low Temperature	-20°C for 500 hrs.	
Humidity	60°C, 95% RH for 150 hrs.	
Heat Cycle	20 times of following cycle. -20°C, 30min.↔Room temp., 30min↓ ↑Room temp., 30min.↔60°C, 30min.	
Vibration	Apply vibration of amplitude of 1.5mm with 10 to 55Hz band to each of 3 perpendicular directions for 2 hrs.	
Shock	Apply shock of 30G sinewave by standard shock tester to each of 3 perpendicular directions for 5 times.	
Soldering Heat	Immerse up to 3.0mm from can case in solder bath of 260±5°C for 10±1 s.	
Hermetic Sealing	Conform to MIL-STD-202F chapter 112D, condition D. Immerse in fluorocarbon bath (FC-40) of 125±5°C for 20 s.	No generation of bubbles.

Notice

■ Notice

1. Caution in design

- (1) Please make sure that your product has been evaluated and confirmed against your specifications when our product is mounted to your product.
- (2) Be sure to provide an appropriate fail-safe function on your product to prevent a second damage that may be caused by the abnormal function or the failure of our product.
- (3) In case of outdoor use, suitable optical filter and water and humidity proof structure should be applied.
- (4) To prevent failure or malfunction, please use a stabilized power supply.
- (5) Please avoid using the sensor in the following conditions because it may cause failure or malfunction.
 - (a) in such a fluid as water, alcohol etc. corrosive gas (SO_2 , Cl_2 , NO_x etc.) or sea breeze
 - (b) in high humidity
 - (c) in a place exposed directly to sun light or headlight of automobile
 - (d) in a place exposed to rapid ambient temperature change
 - (e) in a place exposed directly to an air-conditioner or heat vent
 - (f) strong vibrations
 - (g) in a place exposed to strong electromagnetic field
 - (h) in such a place where infrared ray is shaded
 - (i) in any other place similar to the above (a) through (h)

2. Caution in mounting

- (1) Soldering
 - (a) Hand soldering should be applied.
 - (b) Soldering should be done quickly as following.

Temperature of soldering iron : 350°C	
Distance from can case	Period of time
1–3mm	Within 3seconds per point
Over 3mm	Within 10seconds per point

- (c) Soldering flux should be rosin flux and not contain more than 0.2wt% chlorine.
Soldering flux should be removed after soldering.
 - (2) Cleaning
Soldering flux should be removed after soldering.
Soldering flux may cause malfunction or degradation of character unless sufficiently cleaned.
3. Caution in handling and storage
 - (1) The optical filter of the sensor should not be scratched or soiled.
 - (2) Strong shock should be avoided.
 - (3) Electrostatics and strong electromagnetic field should be avoided.
 - (4) The sensor should be kept on conductive sponge.
 - (5) High temperature, high humidity, fluid such as water or alcohol etc., corrosive gas (SO_2 , Cl_2 , NO_x etc.) and sea breeze should be avoided.

⚠ Note:

1. Export Control

⟨For customers outside Japan⟩

Murata products should not be used or sold for use in the development, production, stockpiling or utilization of any conventional weapons or mass-destructive weapons (nuclear weapons, chemical or biological weapons, or missiles), or any other weapons.

⟨For customers in Japan⟩

For products which are controlled items subject to the "Foreign Exchange and Foreign Trade Law" of Japan, the export license specified by the law is required for export.

2. Please contact our sales representatives or product engineers before using the products in this catalog for the applications listed below, which require especially high reliability for the prevention of defects which might directly damage to a third party's life, body or property, or when one of our products is intended for use in applications other than those specified in this catalog.

- | | |
|-----------------------------|---|
| ① Aircraft equipment | ② Aerospace equipment |
| ③ Undersea equipment | ④ Power plant equipment |
| ⑤ Medical equipment | ⑥ Transportation equipment (vehicles, trains, ships, etc.) |
| ⑦ Traffic signal equipment | ⑧ Disaster prevention / crime prevention equipment |
| ⑨ Data-processing equipment | ⑩ Application of similar complexity and/or reliability requirements to the applications listed in the above |

3. Product specifications in this catalog are as of January 2003. They are subject to change or our products in it may be discontinued without advance notice. Please check with our sales representatives or product engineers before ordering. If there are any questions, please contact our sales representatives or product engineers.

4. Please read rating and ⚠CAUTION (for storage, operating, rating, soldering, mounting and handling) in this catalog to prevent smoking and/or burning, etc.

5. This catalog has only typical specifications because there is no space for detailed specifications. Therefore, please approve our product specifications or transact the approval sheet for product specifications before ordering.

6. Please note that unless otherwise specified, we shall assume no responsibility whatsoever for any conflict or dispute that may occur in connection with the effect of our and/or a third party's intellectual property rights and other related rights in consideration of your use of our products and/or information described or contained in our catalogs. In this connection, no representation shall be made to the effect that any third parties are authorized to use the rights mentioned above under licenses without our consent.

7. No ozone depleting substances (ODS) under the Montreal Protocol are used in our manufacturing process.