

Features

- Full Compliance with USB Spec Rev 1.1
- Four Downstream Ports
- Full-speed and Low-speed Data Transfers
- Bus-powered Controller
- Bus-powered or Self-powered Hub Operation
- Port Overcurrent Monitoring
- Port Power Switching
- 5V Operation with On-chip 3.3V Regulator
- 24-pin SOIC

Description

The AT43301 is a 5-port USB hub chip supporting one upstream and four downstream ports. The AT43301 connects to an upstream hub or host/root hub via Port0, while the other ports connect to external downstream USB devices. The hub re-transmits the USB differential signal between Port0 and Ports[1:4] in both directions. The AT43301 is designed for very low-cost bus-powered or self-powered hub applications and comes in a 24-pin SOIC package.

The AT43301 supports the 12 Mb/s full speed as well as 1.5 Mb/s slow speed USB transactions. To reduce EMI, the AT43301's oscillator frequency is 6 MHz even though some internal circuitry operates at 48 MHz.

Pin Configurations

Top View

VCC	□ 1	24	□ NC
VSS	□ 2	23	□ DP4
CEXT1	□ 3	22	□ DM4
OSC1	□ 4	21	□ DP3
OSC2	□ 5	20	□ DM3
LFT	□ 6	19	□ DP2
STAT	□ 7	18	□ DM2
PWR	□ 8	17	□ DP1
OVC	□ 9	16	□ DM1
LPSTAT	□ 10	15	□ DP0
TEST	□ 11	14	□ DM0
SELF/BUS	□ 12	13	□ VSS



Low-cost USB Hub Controller

AT43301



The AT43301 consists of a Serial Interface Engine, a Hub Repeater, and a Hub Controller.

The Serial Interface Engine's tasks are:

- Manage the USB communication protocol
- USB signaling detection/generation
- Clock/data separation, data encoding/decoding, CRC generation/checking
- Data serialization/deserialization

The Hub Repeater is responsible for:

- Providing upstream connectivity between the selected device and the host

- Managing connectivity setup and tear-down
- Handling bus fault detection and recovery
- Detecting connect/disconnect on each port

The Hub Controller is responsible for:

- Hub enumeration
- Providing configuration information to the Host
- Providing status of each port to the Host
- Controlling each port per host command
- Managing port power supply

Block Diagram

Figure 1.

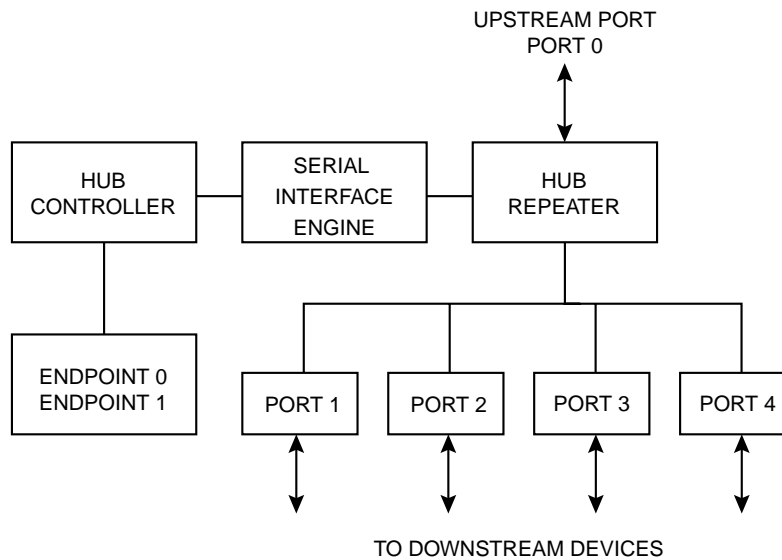

Note: This document assumes that the reader is familiar with the Universal Serial Bus and therefore only describes the unique features of the AT43301 chip. For detailed information about the USB and its operation, the reader should refer to the Universal Serial Bus Specification Version 1.1, September 23, 1998.

Pin Assignment

Type:

I	=	Input
IS	=	Input, Schmitt Trigger
O	=	Output
OD	=	Output, open drain
B	=	Bi-directional
V	=	Power supply, ground

Table 1. Pin Assignment in Numerical Order

Pin#	Signal	Type
1	VCC	V
2	VSS	V
3	CEXT1	O
4	OSC1	I
5	OSC2	O
6	LFT	I
7	$\overline{\text{STAT}}$	OD
8	$\overline{\text{PWR}}$	OD
9	$\overline{\text{OVC}}$	IS
10	LPSTAT	IS
11	$\overline{\text{TEST}}$	I
12	SELF/ $\overline{\text{BUS}}$	IS
13	VSS	V
14	DM0	B
15	DP0	B
16	DM1	B
17	DP1	B
18	DM2	B
19	DP2	B
20	DM3	B
21	DP3	B
22	DM4	B
23	DP4	B
24	NC	-

Table 2. Pin Assignment in Alphabetical Order

Pin#	Signal	Type
3	CEXT1	O
14	DM0	B
16	DM1	B
18	DM2	B
20	DM3	B
22	DM4	B
15	DP0	B
17	DP1	B
19	DP2	B
21	DP3	B
23	DP4	B
6	LFT	I
10	LPSTAT	IS
24	NC	-
4	OSC1	I
5	OSC2	O
9	$\overline{\text{OVC}}$	IS
8	$\overline{\text{PWR}}$	OD
12	SELF/ $\overline{\text{BUS}}$	IS
7	$\overline{\text{STAT}}$	OD
11	$\overline{\text{TEST}}$	I
1	VCC	V
2	VSS	V
13	VSS	V

Table 3. Signal Descriptions

CEXT1	O	External Capacitor. For proper operation of the on-chip regulator, a 0.27 μ F capacitor must be connected to CEXT1.
DP0	B	Upstream Plus USB I/O. This pin should be connected to the CEXT1 pin through an external 1.5 k Ω pull-up resistor. DP0 and DM0 form the differential signal pin pairs connected to the USB host controller or an upstream Hub.
DM0	B	Upstream Minus USB I/O.
DP[1:4]	B	Port Plus USB I/O. This pin should be connected to VSS through an external 15 k Ω resistor. DP[1:4] and DM[1:4] are the differential signal pin pairs to connect downstream USB devices.
DM[1:4]	B	Port Minus USB I/O. This pin should be connected to VSS through an external 15 k Ω resistor.
LFT	I	PLL Filter. For proper operation of the PLL, this pin should be connected through a 2.2 nF capacitor in parallel with a 100 Ω resistor in series with a 10 nF capacitor to ground (VSS).
LPSTAT	I	Local Power Status. Schmitt Trigger input pin that is used in the self-powered mode to indicate the condition of the local power supply. This pin should be connected to the local power supply through a 100 k Ω resistor.
OSC1	I	Oscillator Input. Input to the inverting 6 MHz oscillator amplifier.
OSC2	O	Oscillator Output. Output of the inverting oscillator amplifier.
$\overline{\text{OVC}}$	I	Port Overcurrent. This is the Schmitt Trigger input signal used to indicate to the AT43301 that there is a power supply problem with the ports. If $\overline{\text{OVC}}$ is asserted, the AT43301 will de-assert PWR and report the status to the USB Host.
$\overline{\text{PWR}}$	O	Power Switch. This is an output signal to enable or disable the external port power switch for the port power supply. $\overline{\text{PWR}}$ is de-asserted when an overcurrent is detected at OVC.
$\overline{\text{SELF/BUS}}$	I	Power Mode. Schmitt Trigger input pin to set power mode of hub. If high, the AT43301 works in the self-powered mode. If low, the bus-powered mode.
$\overline{\text{STAT}}$	O	Status. Output pin which is asserted by the AT43301 whenever it is enumerated. $\overline{\text{STAT}}$ is de-asserted when the hub enters the suspend state. An LED in series with a resistor can be connected to this pin to provide visual feedback to the user.
$\overline{\text{TEST}}$	I	Test. This pin has an internal pull up and should be left unconnected in the normal operating mode.
VCC	V	5V Power Supply from the USB.
VSS	V	Ground.
NC	-	No Connect. This pin should be left unconnected.

Functional Description

Summary

The Atmel AT43301 USB hub controller chip contains various features that makes it the ideal solution for very low-cost USB hubs. These features are: on-chip regulator, low-frequency oscillator, bus or self-powered operation, ganged port power switching and global overcurrent protection. Such a hub can be a stand-alone hub used with portable computers to allow convenient connectivity to standard desktop peripheral devices. Alternatively, the hub can be added to an existing non-USB peripheral such as a keyboard. The AT43301 provides 4 downstream USB ports and can operate in a self-powered or bus-powered mode.

USB Ports

The AT43301's upstream port, Port0, is a full speed port. A 1.5 k Ω pull-up resistor to the 3.3V regulator output, CEXT, is required for proper operation. The downstream ports support both full-speed as well as low-speed devices. 15 k Ω pull down resistors are required at their inputs.

Full speed signal requirements demand controlled rise/fall times and impedance matching of the USB ports. To meet these requirements, 22 Ω resistors must be inserted in series between the USB data pins and the USB connectors.

Hub Repeater

The Hub Repeater is responsible for port connectivity setup and teardown. It also supports exception handling such as bus fault detection and recovery, and connect/disconnect detection. Port0 is the root port and is connected to the root hub or an upstream hub. When a packet is received at Port0, the AT43301 propagates it to all the enabled downstream ports. Conversely, a packet from a downstream port is transmitted from Port0.

The AT43301 supports downstream port data signaling at both 1.5 Mb/s and 12 Mb/s. Devices attached to the downstream ports are determined to be either full speed or low speed depending which data line (DP or DM) is pulled high. If a port is enumerated as low speed, its output buffers operate at a slew rate of 75-300 ns, and the AT43301 will not propagate any traffic to that port unless it is prefaced with a preamble PID. Low speed data following the preamble PID is propagated to both low- and full-speed devices. The AT43301 will enable low-speed drivers within four full-speed bit times of the last bit of a preamble PID, and will disable them at the end of an EOP. The upstream traffic from all ports is propagated by Port0 using the full speed 4-20ns slew rate drivers.

All the AT43301 ports independently drive and monitor their DP and DM pins so that they are able to detect and generate the 'J', 'K', and SE0 bus signaling states. Each hub port has single-ended and differential receivers on its DP and DM lines. The ports' I/O buffers comply with the voltage levels and drive requirements as specified in the USB Specifications Rev 1.0.

The Hub Repeater implements a frame timer which is timed by the 12 MHz USB clock and gets reset every time an SOF token is received from the host.

Serial Interface Engine

The Serial Interface Engine handles the USB communication protocol. It performs the USB clock/data separation, the NRZI data encoding/decoding, bit stuffing, CRC generation and checking, USB packet ID decoding and generation, and data serialization and de-serialization. The on-chip phase locked loop generates the high frequency clock for the clock/data separation circuit.

Power Management

A hub is allowed to draw up to 500 mA of power from the host or upstream hub. The AT43301's itself and its external circuitry typically consume about 24 mA. Therefore, in the bus-powered mode, 100 mA is available for each of the hub's downstream devices. In the self-powered mode, an external power supply is required which must be capable of

supplying 500 mA per port. The power supplied to the ports is monitored and controlled by the AT43301.

The AT43301 reports overcurrent on a global basis. The overcurrent signal, which needs to be detected by an external device, is read through the \overline{OVC} pin. A logic low at \overline{OVC} is interpreted as an overcurrent condition. This could be caused by an overload, or a short circuit, and causes the AT43301 to set the Over-Current Indicator bit of the Hub Status Field, wHubStatus, as well as the Over-Current Indicator Change bit of the Hub Change Field, wHubChange. At the same time, power to the ports is switched off by de-asserting \overline{PWR} .

An external device is needed to perform the actual switching of the ports' power under control of the AT43301. The signal to control the external switch is the \overline{PWR} pin which is an open drain signal and requires an external pull-up resistor. 47 k Ω is a typical value for this resistor. Any type of suitable switch or device is acceptable. However, the switch should have a low-voltage drop across it even when the port absorbs full power. In its simplest form, this switch can be a high side MOSFET switch. The advantage of using a MOSFET switch is its very low-voltage drop.

The power control pin, \overline{PWR} , is asserted only when a SetPortFeature[PORT-POWER] request is received from the host. \overline{PWR} is de-asserted under the following conditions:

1. Power up
2. Reset and initialization
3. Overcurrent condition
4. Requested by the host though a ClearPortFeature[PORT_POWER] for ALL the ports

Self-powered Mode

In the self-powered mode, power to the downstream ports must be supplied by an external power supply. This power supply must be capable of supplying 500 mA per port or 2A total with good voltage tolerance and regulation. At full hub operating power, that is all downstream ports drawing 500 mA each, the minimum voltage at the downstream port connector must be 4.75V.

The USB specification requires that the voltage drop at the power switch and board traces be no more than 100 mV. A good conservative maximum drop at the power switch itself should be no more than 75 mV. Careful design and selection of the power switch and PC board layout is required to meet the specifications. When using a MOSFET switch, its resistance must be 40 m Ω or less under worst case conditions. A suitable MOSFET switch for an AT43301 based hub is an integrated highside MOSFET switch such as the Micrel MIC2505.

Bus-Powered Mode

In the bus-powered mode all the power for the hub itself as well as the downstream ports is supplied by the root hub or upstream hub through the USB. Only 100 mA is available for each of the hub's downstream devices and therefore only low-power devices are supported.

The power switch works exactly like the self-powered mode, except that the allowable switch resistance is higher:

140 mΩ or less under the worst case condition. An example of a suitable high side switch for a bus-powered hub is the Micrel MIC2525.

The diagrams of Figure 2 and Figure 3 show examples of the power supply and power management scheme in the self-powered mode and bus-powered mode using an integrated switch with built-in overcurrent protection.

Figure 2. Bus-powered Hub

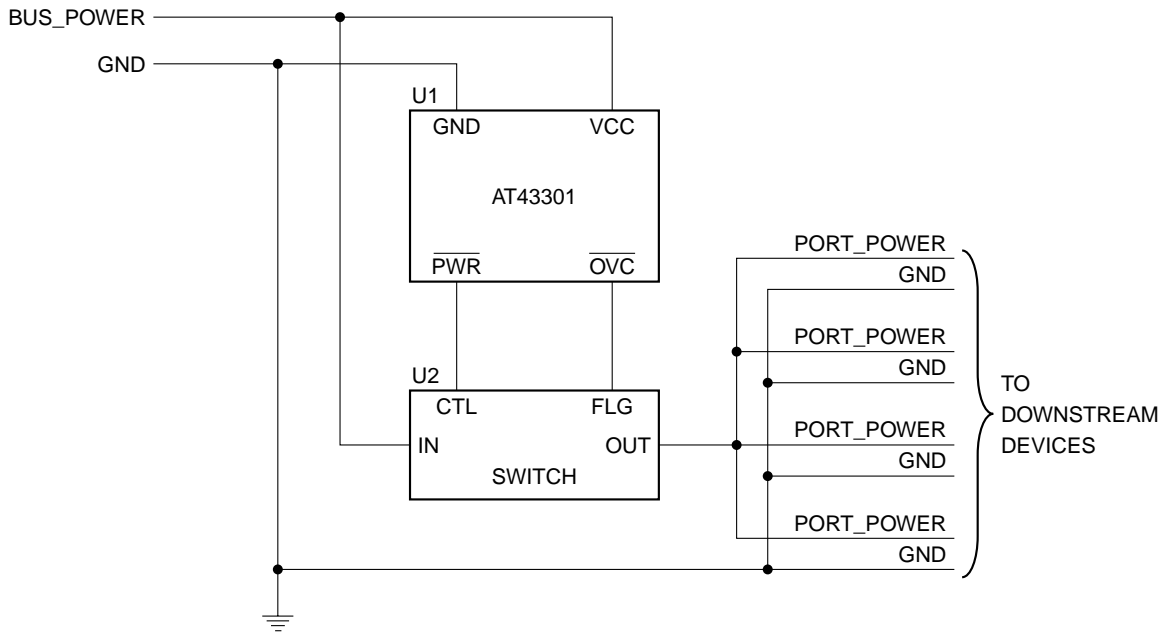
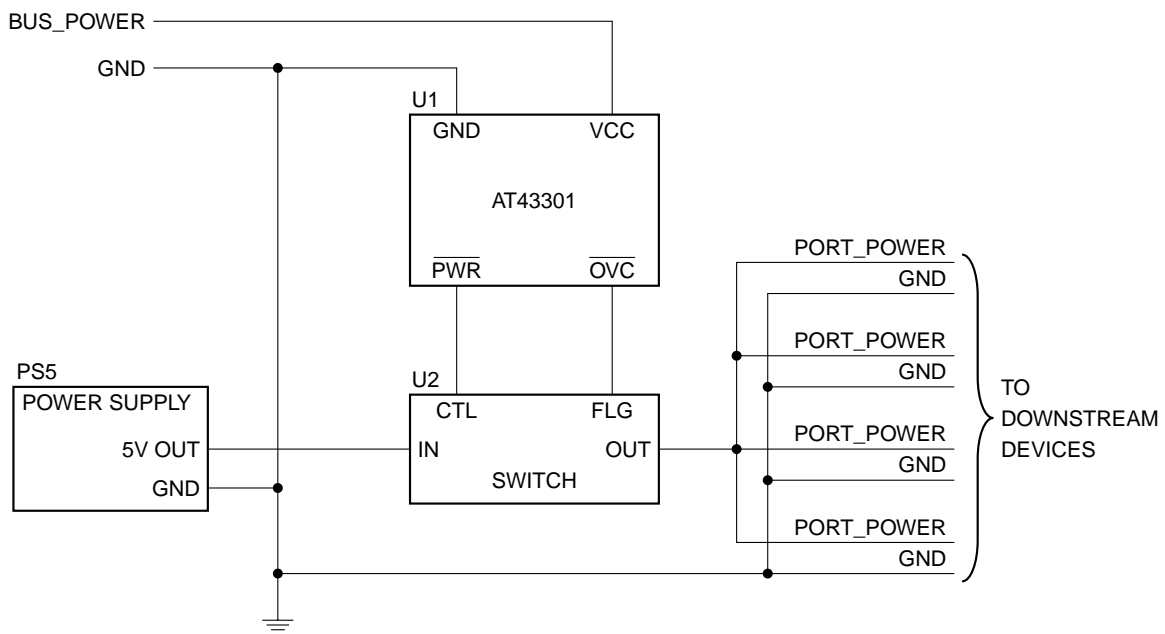

Figure 3. Self-powered Hub



Hub Controller

The Hub Controller of the AT43301 provides the mechanism for the host to enumerate the hub and the AT43301 to provide the host with its configuration information. It also provides a mechanism for the host to monitor and control the downstream ports.

The Hub Controller supports two endpoints, Endpoint0 and Endpoint1.

The Hub Controller maintains a status register, Controller Status Register, which reflects the AT43301's current settings. At power up, all bits in this register will be set to 0's.

Table 4. Controller Status Register

Bit	Function	Value	Description
0	Hub configuration status	0	Set to 0 or 1 by a Set_Configuration Request Hub is not currently configured
		1	Hub is currently configured
1	Hub remote wakeup status	0	Set to 0 or 1 by ClearFeature or SetFeature request. Default value is 0. Hub is currently not enabled to request remote wakeup
		1	Hub is currently enabled to request remote wakeup
2	Endpoint0 STALL status	0	Endpoint0 is not stalled
		1	Endpoint0 is stalled
3	Endpoint1 STALL status	0	Endpoint1 is not stalled
		1	Endpoint1 is stalled

Endpoint 0

Endpoint 0 is the AT43301's default endpoint used for enumeration of the hub and exchange of configuration information and requests between the host and the AT43301. Endpoint 0 supports control transfers.

The Hub Controller supports the following descriptors through Endpoint 0: Device Descriptor, Configuration Descriptor, Interface Descriptor, Endpoint Descriptor, and Hub Descriptor. These descriptors are described in detail elsewhere in this document. Standard USB Device Requests and class-specific Hub Requests are also supported through Endpoint 0. There is no endpoint descriptor for Endpoint0.

Endpoint 1

Endpoint1 is used by the Hub Controller to send status change information to the host. This endpoint supports interrupt transfers.

The Hub Controller samples the changes at the end of every frame at time marker EOF2 in preparation for a potential data transfer in the subsequent frame. The sampled information is stored in a byte wide register, the Status Change Register, using a bitmap scheme.

Each bit in the Status Change Register corresponds to one port as shown below:

Table 5. Status Change Register

Bit	Function	Value	Meaning
0	Hub status change	0	No change in status
		1	Change in status detected
1	Port1 status change	0	No change in status
		1	Change in status detected
2	Port2 status change	0	No change in status
		1	Change in status detected
3	Port3 status change	0	No change in status
		1	Change in status detected
4	Port4 status change	0	No change in status
		1	Change in status detected
5-7	Reserved	000	Default values

An IN Token packet from the host to Endpoint 1 indicates a request for port change status. If the hub has not detected any change on its ports, or any changes in itself, then all bits in this register will be 0 and the Hub Controller will return a NAK to requests on Endpoint1. If any of bits 0-4 is 1, the Hub Controller will transfer the whole byte. The Hub Controller will continue to report a status change when polled until that particular change has been removed by a ClearPortFeature request from the Host. No status change will be reported by Endpoint 1 until the AT43301 has been enumerated and configured by the host.

Oscillator and Phase-Locked-Loop

All the clock signals required to run the AT43301 are derived from an on-chip oscillator. To reduce EMI and power dissipation in the system, the AT43301 is designed to operate with a 6 MHz crystal. An on-chip PLL generates the high frequency for the clock/data separator of the Serial Interface Engine. In the suspended state, the oscillator circuitry is turned off. To assure quick startup, a crystal with a high Q, or low ESR, should be used. To meet the USB hub frequency accuracy and stability requirements for hubs, the crystal should have an accuracy and stability of better than 100 ppm. Even though the oscillator circuit would work with a ceramic resonator, its use is not recommended because a resonator would not have the frequency accuracy and stability.

A 6 MHz series resonance quartz crystal with a load capacitance of approximately 10 pF is recommended. The oscillator is a special low-power design and in most cases no external capacitors and resistors are necessary. If the crystal used cannot tolerate the drive levels of the oscillator, a series resistor between OSC2 and the crystal pin is recommended.

Status Pin

The status pin, $\overline{\text{STAT}}$, is provided to allow feedback to the user. If an LED and a series resistor is connected between $\overline{\text{STAT}}$ and VCC, the LED will light when the hub is enumerated. During an overcurrent condition, the LED will blink. It will continue to blink until the host turns off the power to the ports or until the hub is re-enumerated.

Figure 4. External Oscillator and PLL Circuit

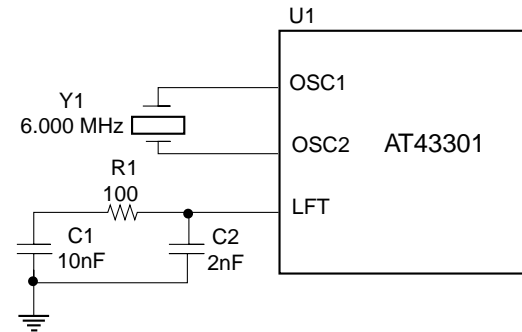

The clock can also be externally sourced. In this case, connect the clock source to the OSC1 pin, while leaving OSC2 pin floating. The switching level at the OSC1 pin can be as low as 0.47V (see “Electrical Specification” on page 9) and a CMOS device is required to drive this pin to maintain good noise margins at the low switching level.

For proper operation of the PLL, an external RC filter consisting of a series RC network of 100Ω and 10 nF in parallel with a 2 nF capacitor must be connected from the LFT pin to V_{SS} .

Power Supply

The AT43301 is powered from the USB bus, but has an internal voltage regulator to supply the 3.3V operating power to its circuitry. For proper operation, an external high quality, low ESR, 0.27 μF, or larger, capacitor should be connected to the output of the regulator, CEXT1 and ground. The CEXT1 pin can also be used to supply the voltage to the 1.5 kΩ pull up resistor at Port 0's DP pin.

To provide the best operating condition for the AT43301, careful consideration of the power supply connections are recommended. Use short, low impedance connections to all power supply lines: V_{CC} and V_{SS} . Use sufficient decoupling capacitance to reduce noise: 0.1 μF of high quality ceramic capacitor soldered as close as possible to the VCC and VSS package pins are recommended.

Electrical Specification

Absolute Maximum Ratings*

Symbol	Parameter	Condition	Min	Max	Unit
V _{CC5}	5V Power Supply			5.5	V
V _I	DC Input Voltage		-0.3V	V _{CEXT} + 0.3 4.6 max	V
V _O	DC Output Voltage		-0.3	V _{CEXT} + 0.3 4.6 max	V
T _O	Operating Temperature		-40	+125	°C
T _S	Storage Temperature		-65	+150	°C

*NOTICE: Stresses beyond those listed under “Absolute Maximum Ratings” may cause permanent damage to the device. This is a stress rating only and functional operation of the device at these or any other conditions beyond those indicated in the operational sections of this specification is not implied. Exposure to absolute maximum rating conditions for extended periods may affect device reliability.

DC Characteristics

The values shown in this table are valid for T_A = 0°C to 85°C, V_{CC} = 4.4V to 5.25V, unless otherwise noted.

Table 6. Power Supply

Symbol	Parameter	Condition	Min	Max	Unit
V _{CC}	5V Power Supply		4.4	5.25	V
I _{CC}	5V Supply Current			24	mA
I _{CCS}	Suspended Device Current			150	µA

Table 7. USB Signals: DPx, DMx

Symbol	Parameter	Condition	Min	Max	Unit
V _{IH}	Input Level High (driven)		2.0		V
V _{IHZ}	Input Level High (floating)		2.7	3.6	V
V _{IL}	Input Level Low			0.8	V
V _{DI}	Differential Input Sensitivity	DPx and DMx	0.2		V
V _{CM}	Differential Common Mode Range		0.8	2.5	V
V _{OL1}	Static Output Low	R _L of 1.5 kΩ to 3.6V		0.3	V
V _{OH1}	Static Output High	R _L of 15 kΩ to GND	2.8	3.6	V
V _{CRS}	Output Signal Crossover		1.3	2.0	V
C _{IN}	Input Capacitance			20	pF

Table 8. $\overline{\text{PWR}}$, $\overline{\text{STAT}}$, $\overline{\text{OVC}}$

Symbol	Parameter	Condition	Min	Max	Unit
V_{OL2}	Output Low Level, $\overline{\text{PWR}}$, $\overline{\text{STAT}}$	$I_{OL} = 4 \text{ mA}$		0.5	V
C_{OUT}	Output Capacitance	1 MHz		10	pF
V_{IL3}	Input Low Level			$0.3V_{CEXT}$	V
V_{IH3}	Input High Level		$0.7V_{CEXT}$		V
C_{OUT}	Output Capacitance	1 MHz		10	pF
V_{OH2}	Output High Level, $\overline{\text{PWR}}$	$I_{OH} = 4 \text{ mA}$	$V_{CEXT} - 0.5$		V

Table 9. Oscillator Signals: OSC1, OSC2

Symbol	Parameter	Condition	Min	Max	Unit
V_{LH}	OSC1 Switching Level		0.47	1.20	V
V_{HL}	OSC1 Switching Level		0.67	1.44	V
C_{X1}	Input Capacitance, OSC1			17	pF
C_{X2}	Output Capacitance, OSC2			17	pF
C_{12}	OSC1/2 Capacitance			1	pF
tsu	Start-up Time	6 MHz, fundamental		2	ms
D_L	Drive Level	$V_{CC} = 3.3V$, 6 MHz crystal, 100 Ω equiv series resistor		150	μW

Note: OSC2 must not be used to drive other circuitry.

AC Characteristics

Table 10. DPx, DMx Driver Characteristics, Full Speed Operation

Symbol	Parameter	Condition	Min	Max	Unit
t_R	Rise Time	$C_L = 50 \text{ pF}$	4	20	ns
t_F	Fall Time	$C_L = 50 \text{ pF}$	4	20	ns
t_{RFM}	t_R/t_F Matching		90	110	%
Z_{DRV}	Driver Output Resistance ⁽¹⁾	Steady state drive	28	44	Ω

Note: 1. With external 22 Ω series resistor.

Table 11. DPx, DMx Source Timings, Full Speed Operation

Symbol	Parameter	Condition	Min	Max	Unit
t_{DRATE}	Full Speed Data Rate ⁽¹⁾	Average bit rate	11.97	12.03	Mb/s
t_{FRAME}	Frame Interval ⁽¹⁾		0.9995	1.0005	ms
t_{RFI}	Consecutive Frame Interval Jitter ⁽¹⁾	No clock adjustment		42.0	ns
t_{RFIADJ}	Consecutive Frame Interval Jitter ⁽¹⁾	With clock adjustment		126.0	ns
t_{DJ1} t_{DJ2}	Source Diff Driver Jitter To Next Transition		-3.5	3.5	ns
	For Paired Transitions		-4.0	4.0	ns
t_{FDEOP}	Source Jitter for Differential Transition to SEO Transitions		-2.0	5.0	ns
t_{JR1} t_{JR2}	Recvr Data Jitter Tolerance To Next Transition		-18.5	18.5	ns
	For Paired Transitions		-9.0	9.0	ns
t_{FEOPT}	Source SEO interval of EOP		160.0	175.0	ns
t_{FEOPR}	Receiver SEO interval of EOP		82.0		ns
t_{FST}	Width of SEO interval during differential transition			14.0	ns

Note: 1. With 6.000 MHz, 100 ppm crystal.

Table 12. DPx, DMx Driver Characteristics, Low-speed Operation

Symbol	Parameter	Condition	Min	Max	Unit
t_R	Rise time	$C_L = 200 - 600$ pF	75.0	300.0	ns
t_F	Fall time	$C_L = 200 - 600$ pF	75.0	300.0	ns
t_{RFM}	t_R/t_F matching		80.0	125.0	%

Table 13. DPx, DMx Hub Timings, High-Speed Operation

Symbol	Parameter	Condition	Min	Max	Unit
t_{HDD2}	Hub Differential Data Delay without Cable			44.0	ns
t_{HDJ1} t_{HDJ2}	Hub Diff Driver Jitter To Next Transition		-3.0	3.0	ns
	For Paired Transitions		-1.0	1.0	ns
t_{FSOP}	Data Bit Width Distortion after SOP		-5.0	5.0	ns
t_{FEOPD}	Hub EOP Delay Relative to t_{HDD}		0	15.0	ns
t_{FHESK}	Hub EOP Output Width Skew		-15.0	15.0	ns

Table 14. DPx, DMx Hub Timings, Low-speed Operation

Symbol	Parameter	Condition	Min	Max	Unit
t_{LHDD}	Hub Differential Data Delay			300.0	ns
t_{LHDJ1}	Downstr Hub Diff Driver Jitter To Next Transition, downst		-45.0	45.0	ns
t_{LHDJ2}	For Paired Transitions, downst		-15.0	15.0	ns
t_{LUHJ1}	To Next Transition, upstr		-45.0	45.0	ns
t_{LUHJ2}	For Paired Transitions, upstr		-45.0	45.0	ns
t_{SOP}	Data Bit Width Distortion after SOP		-60.0	60.0	ns
t_{LEOPD}	Hub EOP Delay Relative to t_{HDD}		0	200.0	ns
t_{LHESK}	Hub EOP Output Width Skew		-300.0	300.0	ns

Table 15. Hub Event Timings

Symbol	Parameter	Condition	Min	Max	Unit
t_{DCNN}	Time to Detect a Downstream Port Connect Event Awake Hub Suspended Hub		2.5 2.5	2000.0 12000.0	μ s μ s
t_{DDIS}	Time to Detect a Disconnect Event on Downstream Port Awake Hub Suspended Hub		2.5 2.5	2.5 10000.0	μ s μ s
t_{URSM}	Time from Detecting Downstream Resume to Rebroadcast			100.0	μ s
t_{DRST}	Duration of Driving Reset to a Downstream Device	Only for a SetPortFeature (PORT_RESET) request	10.0	20.0	ms
t_{URLK}	Time to Detect a Long K from Upstream		2.5	100.0	μ s
t_{URLSEO}	Time to Detect a Long SEO from Upstream		2.5	10000.0	μ s
t_{URPSEO}	Duration of repeating SEO Upstream			23	FS bit time

Timing Waveforms

Figure 5. Data Signal Rise and Fall Time

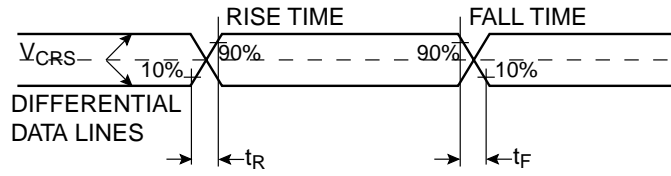

Figure 6. Full-Speed Load

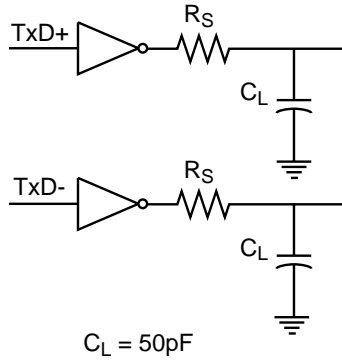

Figure 7. Low-speed Downstream Port Load

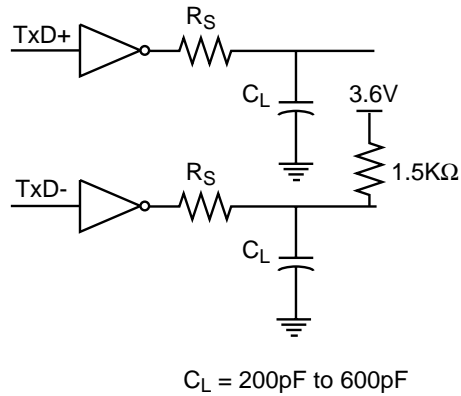

Figure 8. Differential Data Jitter

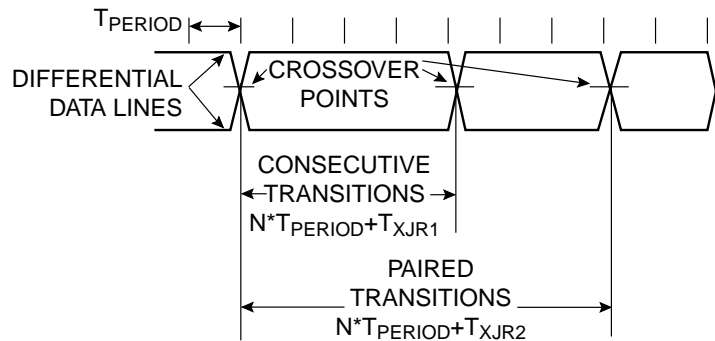

Figure 9. Differential-to-EOP Transition Skew and EOP Width

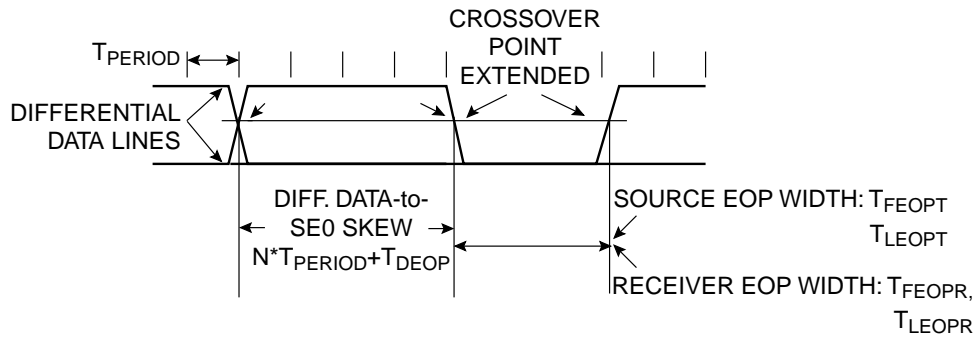

Figure 10. Receiver Jitter Tolerance

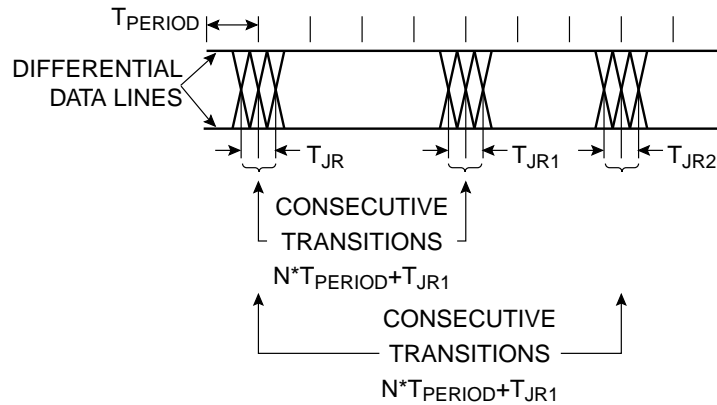
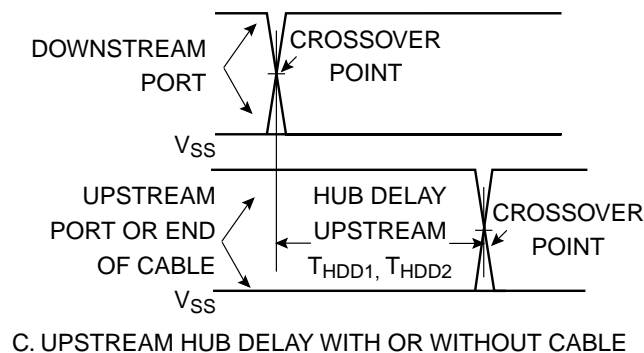
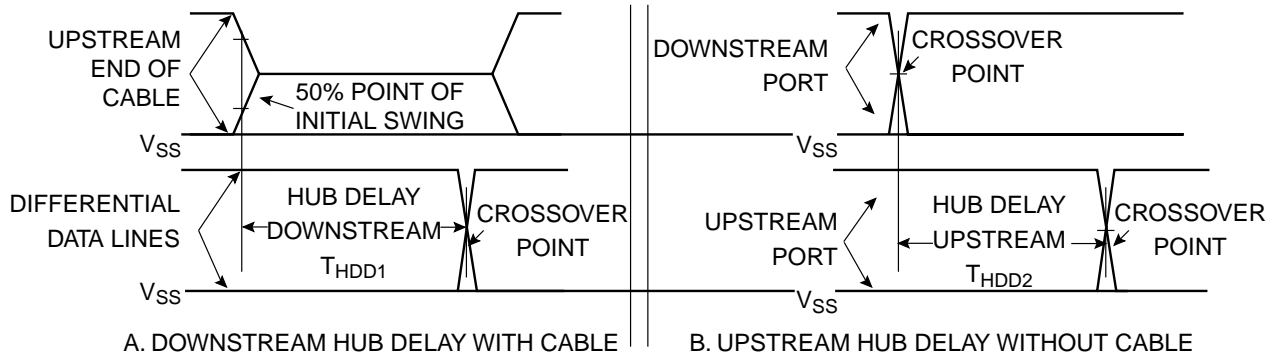

Figure 11. Hub Differential Delay, Differential Jitter, and SOP Distortion



Hub Differential Jitter:

$T_{HDJ1} = T_{HDDX}(J) - T_{HDDX}(K)$ or $T_{HDDX}(K) - T_{HDDX}(J)$ Consecutive Transitions

$T_{HDJ2} = T_{HDDX}(J) - T_{HDDX}(J)$ or $T_{HDDX}(K) - T_{HDDX}(K)$ Paired Transitions

Bit After Sop Width Distortion (Same as Data Jitter for Sop and Next J Transition):

$T_{SOP} = T_{HDDX}(NEXTJ) - T_{HDDX}(SOP)$

Low-speed timings are determined in the same way for:

$T_{LHDD}, T_{LDHJ1}, T_{LDJH2}, T_{LUHJ1}, T_{LUJH2},$ and T_{LSOP}

Figure 12. Hub EOP Delay and EOP Skew

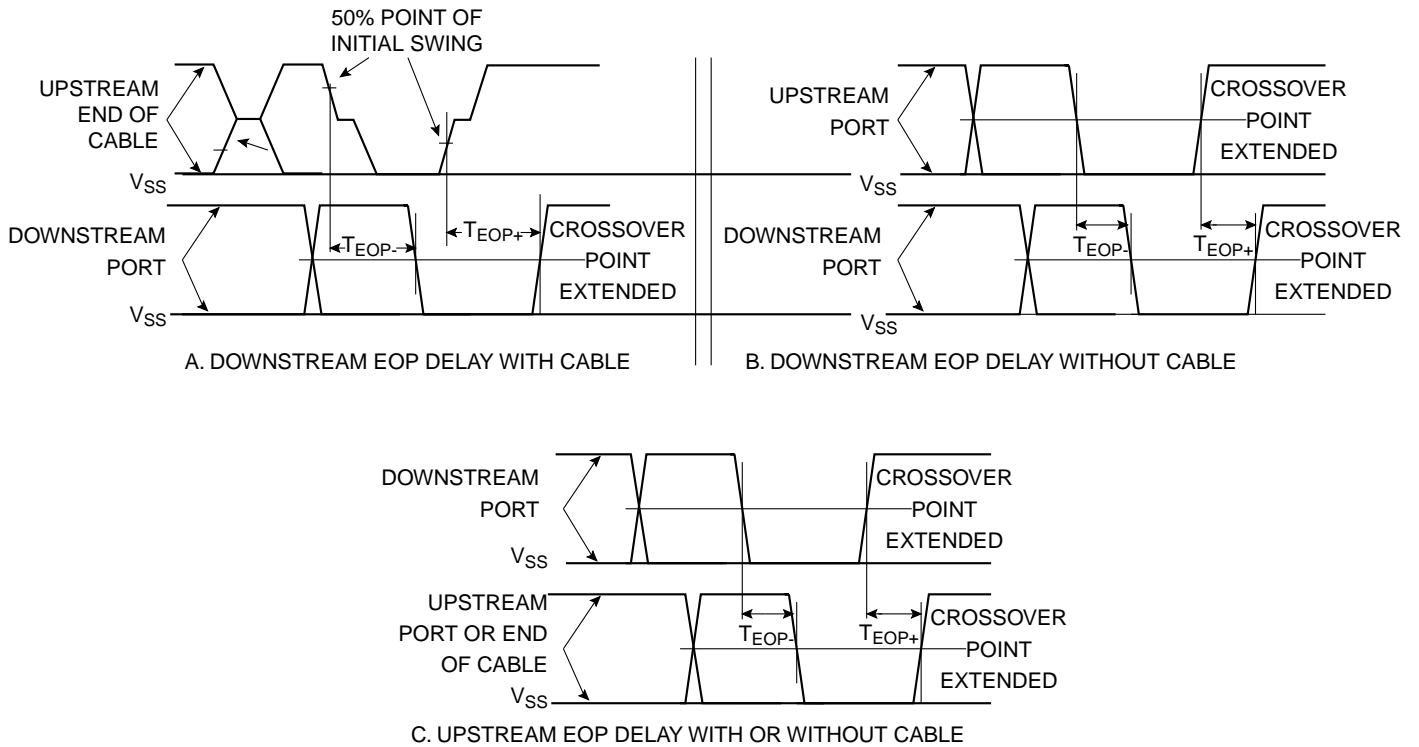

EOP Delay:

$T_{EOPD} = T_{EOP} - T_{HDDX}$

EOP Skew:

$T_{HESK} = T_{EOP+} - T_{EOP-}$

Low-speed timings are determined in the same way for:

T_{LEOPD} and T_{LHESK}

Schematic Diagrams

The following pages shows schematic diagrams of an AT43301 based bus-powered hub and self-powered hub.
Figure 13. Bus-powered Hub

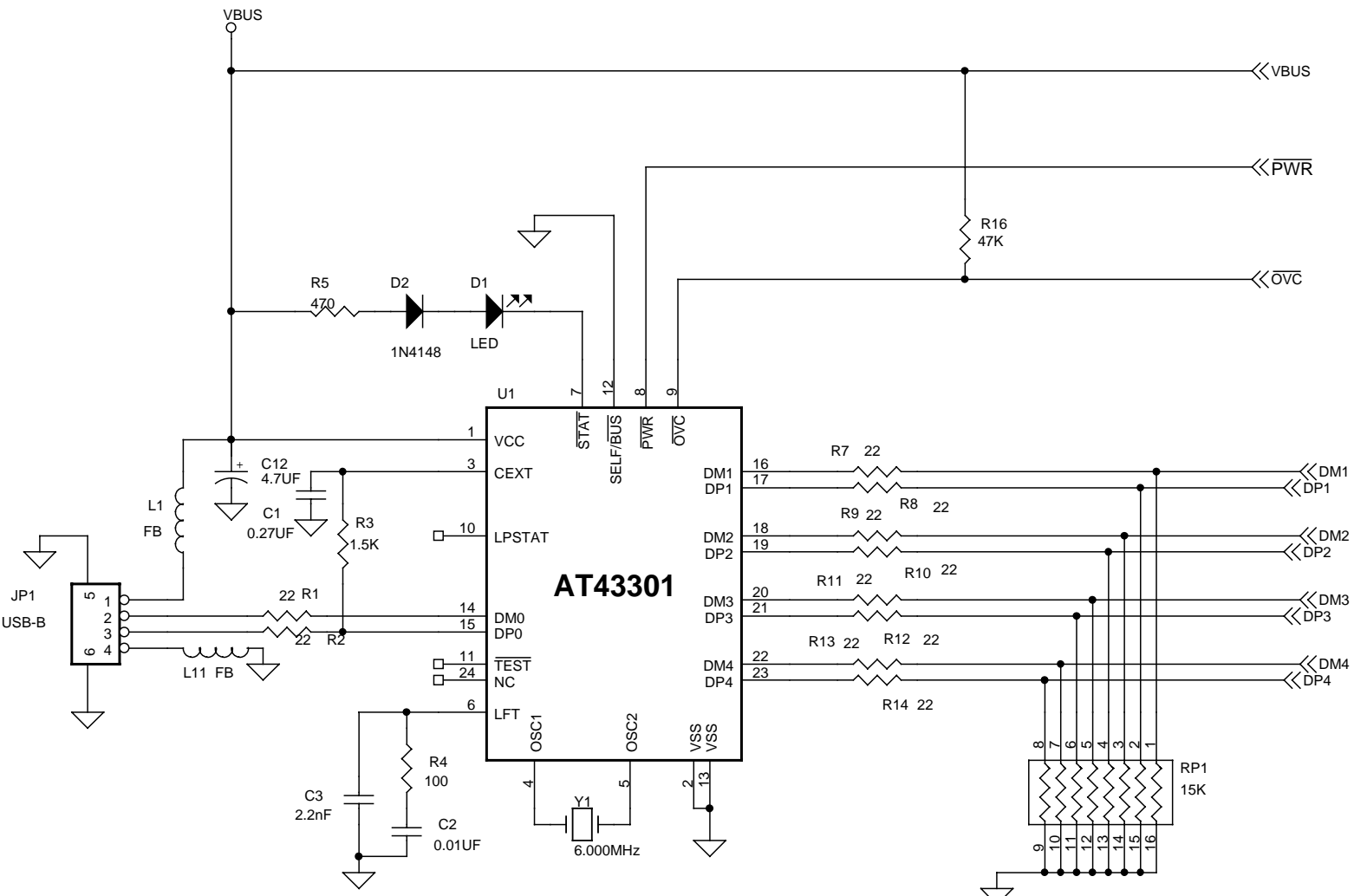

Figure 14. Bus-powered Hub

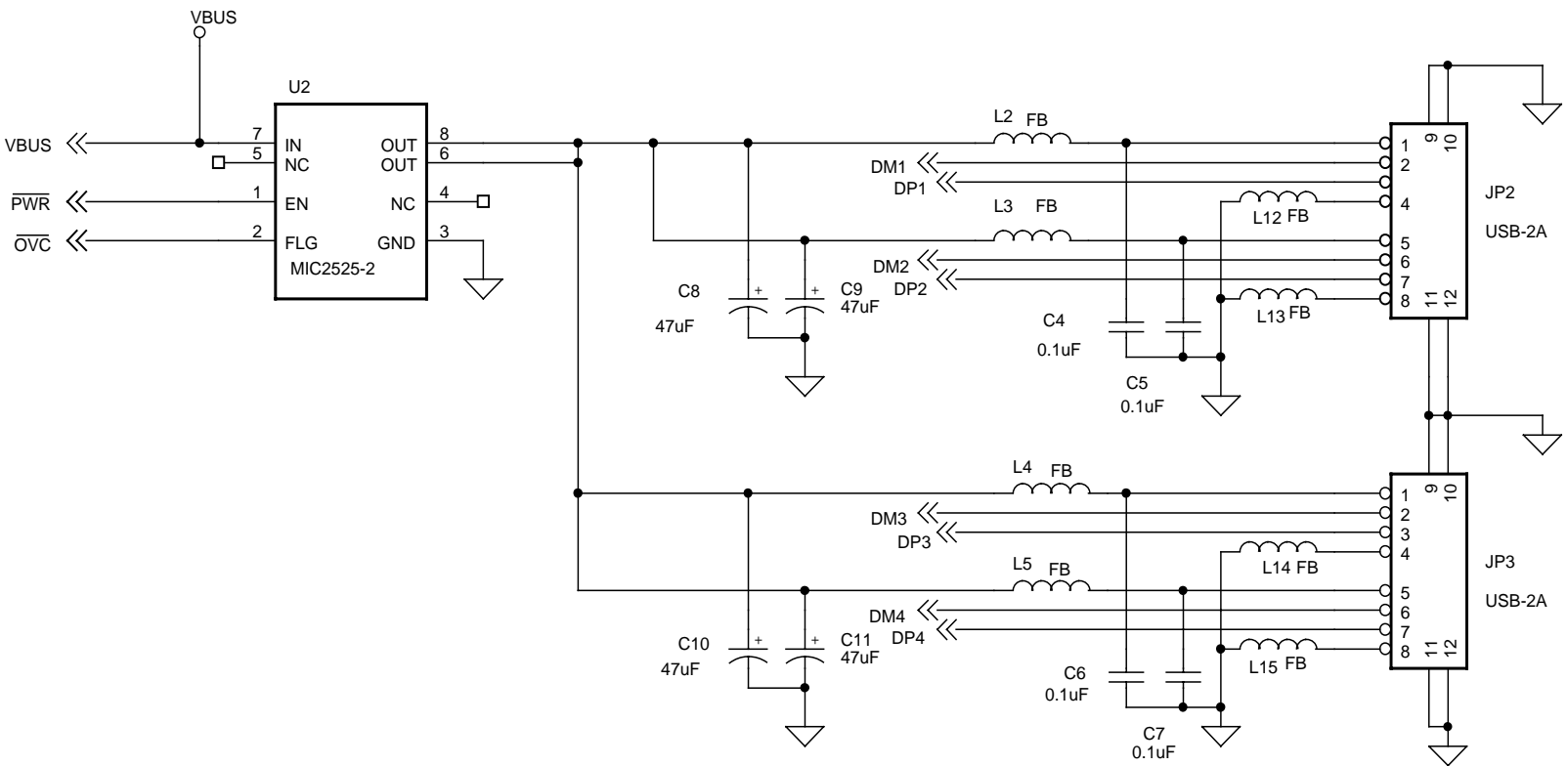

Figure 15. Self-powered Hub

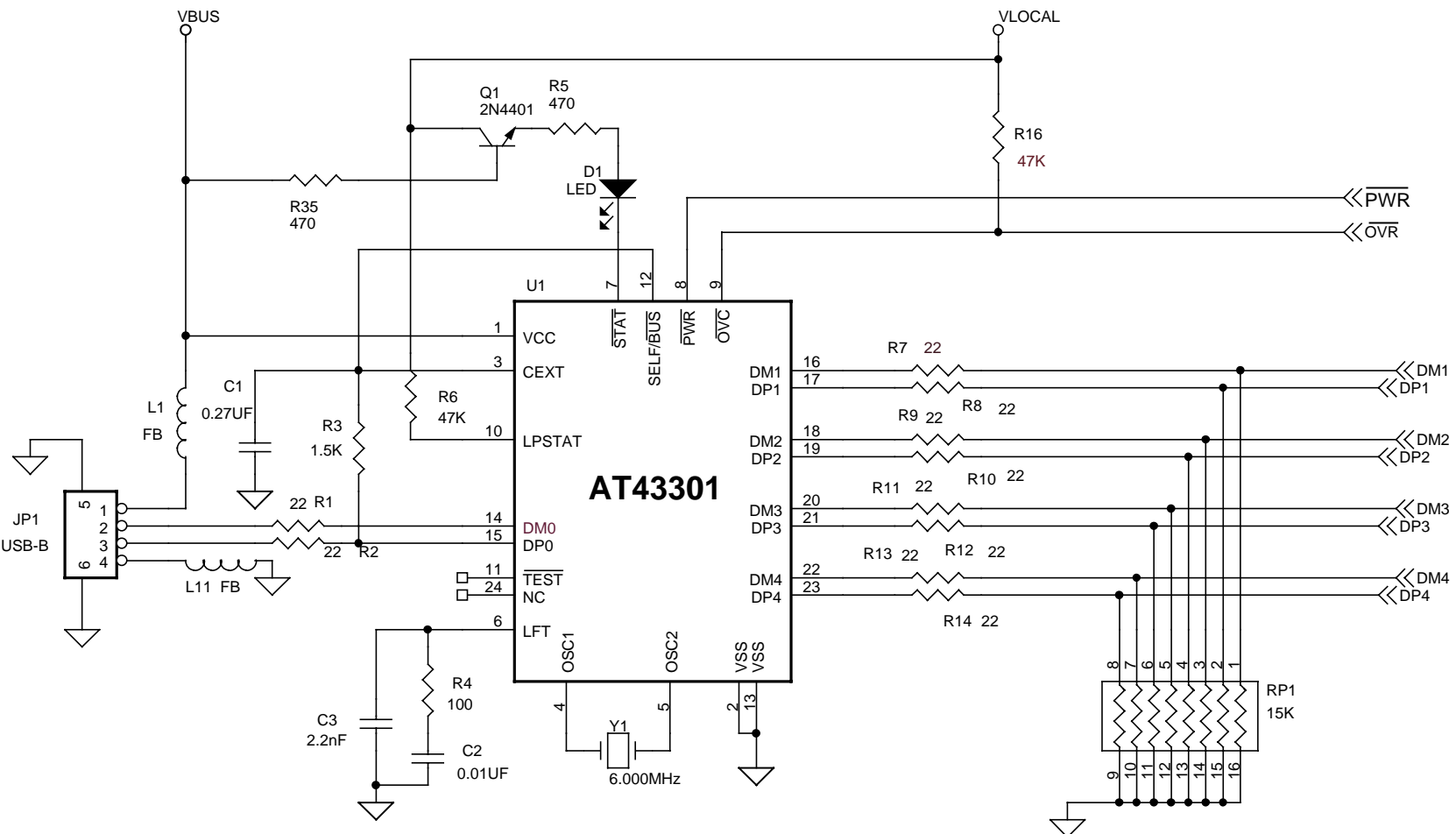
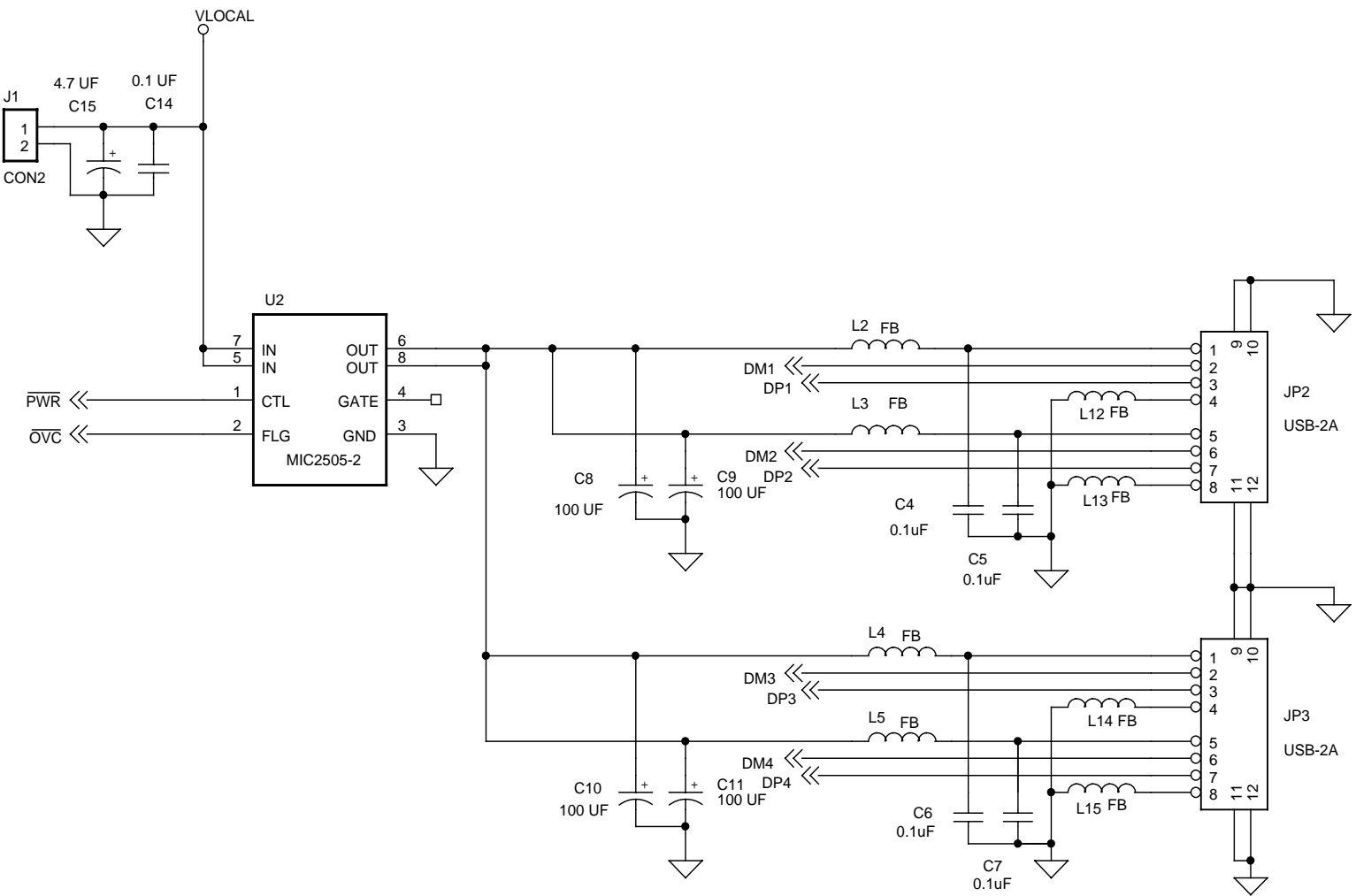
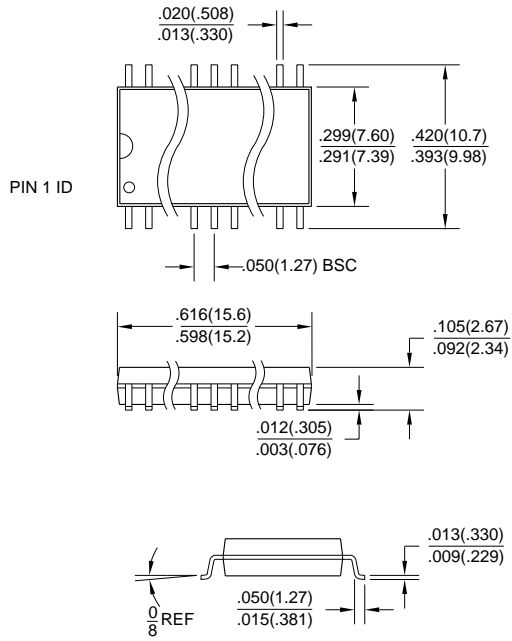

Figure 16. Self-powered Hub



Packaging Information

24S, 24-lead, 0.300" Wide Plastic Gull Wing Small Outline Package (SOIC)
 Dimensions in Inches and (Millimeters)





Atmel Headquarters

Corporate Headquarters

2325 Orchard Parkway
San Jose, CA 95131
TEL (408) 441-0311
FAX (408) 487-2600

Europe

Atmel U.K., Ltd.
Coliseum Business Centre
Riverside Way
Camberley, Surrey GU15 3YL
England
TEL (44) 1276-686-677
FAX (44) 1276-686-697

Asia

Atmel Asia, Ltd.
Room 1219
Chinachem Golden Plaza
77 Mody Road Tsimhatsui
East Kowloon
Hong Kong
TEL (852) 2721-9778
FAX (852) 2722-1369

Japan

Atmel Japan K.K.
9F, Tonetsu Shinkawa Bldg.
1-24-8 Shinkawa
Chuo-ku, Tokyo 104-0033
Japan
TEL (81) 3-3523-3551
FAX (81) 3-3523-7581

Atmel Operations

Atmel Colorado Springs

1150 E. Cheyenne Mtn. Blvd.
Colorado Springs, CO 80906
TEL (719) 576-3300
FAX (719) 540-1759

Atmel Rousset

Zone Industrielle
13106 Rousset Cedex
France
TEL (33) 4-4253-6000
FAX (33) 4-4253-6001

Fax-on-Demand

North America:
1-(800) 292-8635
International:
1-(408) 441-0732

e-mail

literature@atmel.com

Web Site

<http://www.atmel.com>

BBS

1-(408) 436-4309

© Atmel Corporation 1999.

Atmel Corporation makes no warranty for the use of its products, other than those expressly contained in the Company's standard warranty which is detailed in Atmel's Terms and Conditions located on the Company's web site. The Company assumes no responsibility for any errors which may appear in this document, reserves the right to change devices or specifications detailed herein at any time without notice, and does not make any commitment to update the information contained herein. No licenses to patents or other intellectual property of Atmel are granted by the Company in connection with the sale of Atmel products, expressly or by implication. Atmel's products are not authorized for use as critical components in life support devices or systems.

Marks bearing ® and/or ™ are registered trademarks and trademarks of Atmel Corporation.

Terms and product names in this document may be trademarks of others.



Printed on recycled paper.

1137C-08/99/xM