

BTRS-7840C / BTRS-7840C-SP

1310 nm TX/ 1490 nm RX , 3.3V / 1250 Mbps **RoHS Compliant** Single-Fiber Transceiver

FEATURES

- | Bi-Directional Single-Fiber Transceiver
- | Compliant with IEEE 802.3ah 1000BASE-BX
- | 1310 nm DFB LD Transmitter
- | 1490 nm Receiver
- | 1550 nm Enhanced Band Block
- | 20 dB Power Budget At Least
- | Link distance up to 40 km
- | Industry Standard 1 x 9 Footprint
- | Single +3.3 V Power Supply
- | RoHS Compliant
- | 0 to 70°C Operating
- | LVPECL Differential Inputs and Outputs
- | LVTTTL Signal Detect Output
- | Wave Solderable and Aqueous Washable
- | Class 1 Laser International Safety Standard IEC-60825 Compliant

APPLICATIONS

- | WDM Gigabit Ethernet Links
- | SONET/SDH Equipment Interconnect
- | Fiber Channel Links

DESCRIPTION

The BTRS-7840CG series is high performance module for single fiber communications by using 1310 nm transmitter and 1490 nm receiver. **This module is equipped with 3W-TRX™ OE device to reject 1.55 um high power video signal.** The transmitter section uses a multiple quantum well 1310 nm DFB laser and is a class 1 laser compliant according to International Safety Standard IEC-60825. The receiver section is designed to receive 1490 nm and block 1550 nm signal. This feature is suitable for IEEE 802.3ah 1000BASE-BX and ITU-T 983.3 application. The receiver section uses an integrated 1490 nm detector preamplifier (IDP) mounted in an optical header and a limiting post-amplifier IC. A PECL logic interface simplifies interface to external circuitry.

LASER SAFETY

This single mode transceiver is a Class 1 laser product. It complies with IEC-60825 and FDA 21 CFR 1040.10 and 1040.11. The transceiver must be operated within the specified temperature and voltage limits. The optical ports of the module shall be terminated with an optical connector or with a dust plug.

ORDER INFORMATION

P/No.	IEEE 802.3ah 1000BASE	Bit Rate (Gb/s)	Distance (km)	TX (nm)	RX (nm)	Voltage (V)	Package	Temp (°C)	TX Power (dBm)	RX Sens. (dBm)	RoHS Compliant
BTRS-7840CG	BX	1.25	40	1310 DFB	1490	3.3	SC, 2X5	0 to 70	2 to -3	-23	Yes

- Note: 1. BTRS-XXXXXG is SC/PC receptacle type package with standard case
 2. BTRS-XXXXXEG is SC/PC eceptacle type package with extended case
 3. BTRS-XXXXX-APBBBG is pigtail type package with different connector, A=S is SC connector, A=F is FC connector, A=T is ST connector, A=L is LC connector, A=M is MU connector; BBB is the length of fiber in cm.

Absolute Maximum Ratings					
Parameter	Symbol	Min	Max	Units	Notes
Storage Temperature	Tstg	-40	85	°C	
Operating Temperature	Topr	0	70	°C	air flow 1m/sec
Soldering Temperature	---		260	°C	10 seconds on leads only
Power Supply Voltage	Vcc	0	3.6	V	
Input Voltage	---	GND	Vcc	V	
Output Current	Iout	0	30	mA	

Recommended Operating Conditions					
Parameter	Symbol	Min	Typ	Max	Units / Notes
Power Supply Voltage	Vcc	3.13	3.3	3.47	V
Operating Temperature	Topr	0		70	°C /air flow 1m/sec
Data Rate			1250	1300	Mb/s
Power Supply Current	Icc			280	mA

Transmitter Specifications (0°C < Topr < 70°C, 3.13V < Vcc < 3.47V)						
Parameter	Symbol	Min	Typ	Max	Units	Notes
Optical						
Optical Transmit Power	P _o	-3		2	dBm	1
Output Center Wavelength	λ	1260	1310	1360	nm	
Output Spectrum Width	σ _λ			1	nm	-20 dB Width
Side Mode Suppression Ratio	SMSR	30			dB	
Extinction Ratio	E _R	9			dB	
Output Eye	Compliant with IEEE 802.3z					
Optical Rise Time	t _r			0.26	ns	20% to 80% Values
Optical Fall Time	t _f			0.26	ns	20% to 80% Values
Relative Intensity Noise	RIN			-120	dB/Hz	
Total Jitter	TJ			0.227	ns	2
Electrical						
Data Input Current – Low	I _{IL}	-350			μA	
Data Input Current – High	I _{IH}			350	μA	
Differential Input Voltage	V _{IH} - V _{IL}	300		1600	mV	
Data Input Voltage – Low	V _{IL} - V _{CC}	-2.0		-1.58	V	3
Data Input Voltage -- High	V _{IH} - V _{CC}	-1.1		-0.74	V	3
Disable Input Voltage -- Low	V _{TDIS,L}	0		0.8	V	TX Output Enabled
Disable Input Voltage -- High	V _{TDIS,H}	V _{CC} - 1.3		V _{CC}	V	TX Output Disabled
Shut Off Time for TxDis	t _{DIS}			1	ms	

- Notes: 1. Output power is power coupled into a 9/125 μm single mode fiber.
 2. Measured with a 2⁷-1 PRBS.
 3. These inputs are compatible with 10K, 10KH and 100K ECL and LVPECL inputs.

Receiver Specifications (0°C < Topr < 70°C, 3.13 V < Vcc < 3.47V)						
Parameter	Symbol	Min	Typ	Max	Units	Notes
Optical						
Sensitivity	---	---	---	-23	dBm	1
Maximum Input Power	P _{in}	-3	---	---	dBm	
Signal Detect -- Asserted	P _a	---	---	-23	dBm	Transition: low to high
Signal Detect -- Deasserted	P _d	-40	---	---	dBm	Transition: high to low
Signal detect -- Hysteresis		1.0	---		dB	
Wavelength of Operation		1480		1500	nm	2,3
Optical Return Loss	ORL	20			dB	
Electrical						
Data Output Voltage Swing	V _{OH} - V _{OL}	0.575		0.930	V	
SD Output Voltage -- Low	V _{OL}	0		0.8	V	
SD Output Voltage -- High	V _{OH}	2.0		V _{CC} +0.3	V	
Signal Detect Assert Time	AS _{MAX}			100	μs	OFF to ON
Signal Detect Deassert Time	ANS _{MAX}			300	μs	ON to OFF

- Notes: 1. Minimum sensitivity and saturation levels at BER 1E-12 for a 2⁷-1 PRBS.
 2. At least 30 dB optical isolation for the wavelength 1260 to 1360 nm.
 3. At least 30 dB optical isolation for the wavelength 1550 to 1600 nm.

CONNECTION DIAGRAM



PIN	Symbol	Notes
1	V_{EE}^r	Directly connect this pin to the receiver ground plane
2	V_{CC}^r	+3.3V dc power for the receiver section
3	SD	Active high on this indicates a received optical signal.
4	RD-	Receiver Dataout Bar. See recommended circuit schematic
5	RD+	Receiver Dataout. See recommended circuit schematic
6	V_{CC}^t	+3.3V dc power for the transmitter section
7	V_{EE}^t	Directly connect this plan to the transmitter ground plane
8	TxDis	Transmitter Disable. Connect this pin to +3.3V TTL logic "1" to disable module To enable module connect to TTL logic low "0"
9	TD+	Transmitter Data In. See recommended circuit schematic
10	TD-	Transmitter Data In Bar. See recommended circuit schematic
MS	MS	Mounting Studs. Connect to Chassis Ground

RECOMMENDED CIRCUIT SCHEMATIC

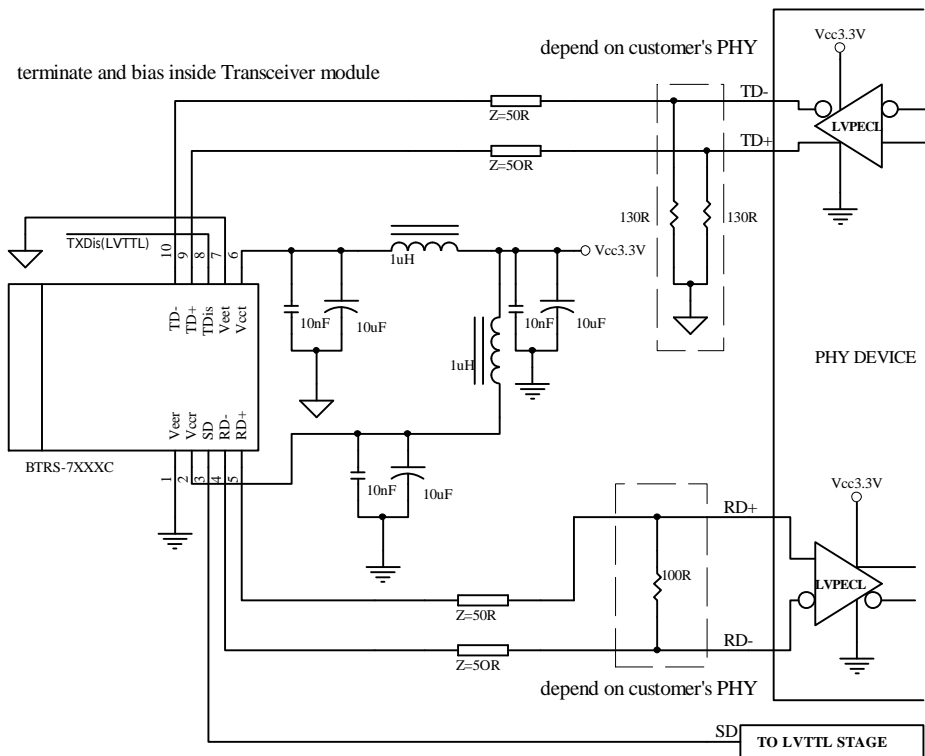

PACKAGE DIAGRAM

Units in mm

1) SC Receptacle

A) Standard Case

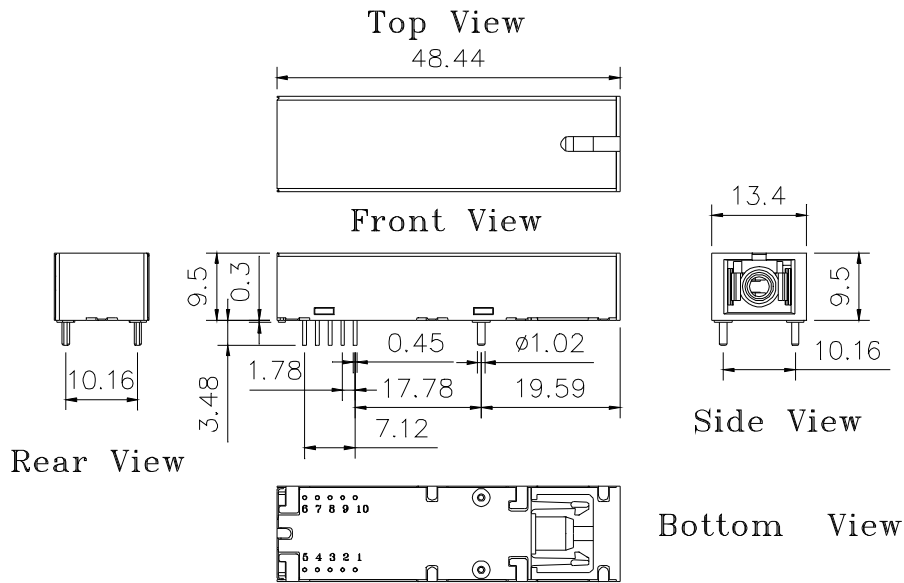

BTRS-7840CG / BTRS-7840ACG

B) Extended Case

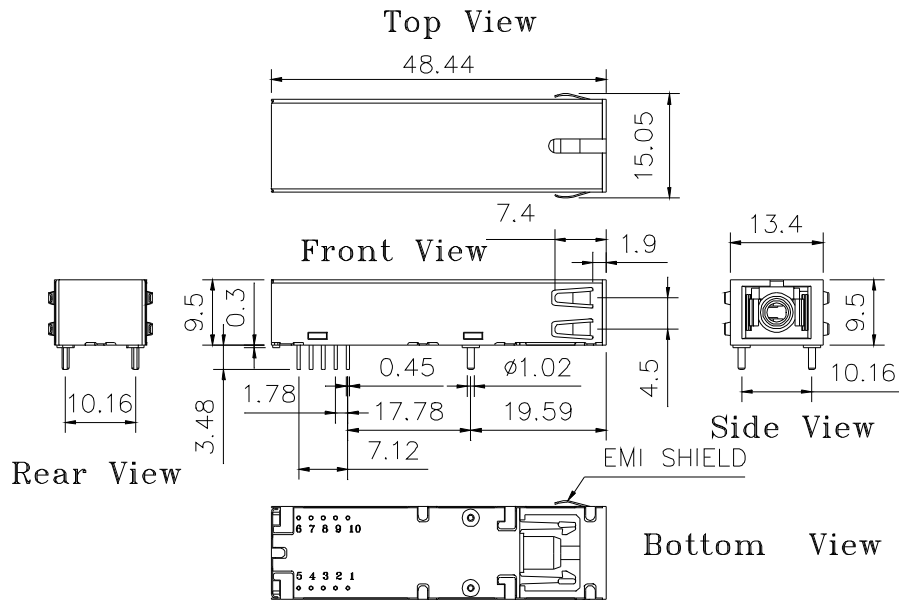

BTRS-7840CEG / BTRS-7840ACEG

2) Pigtail

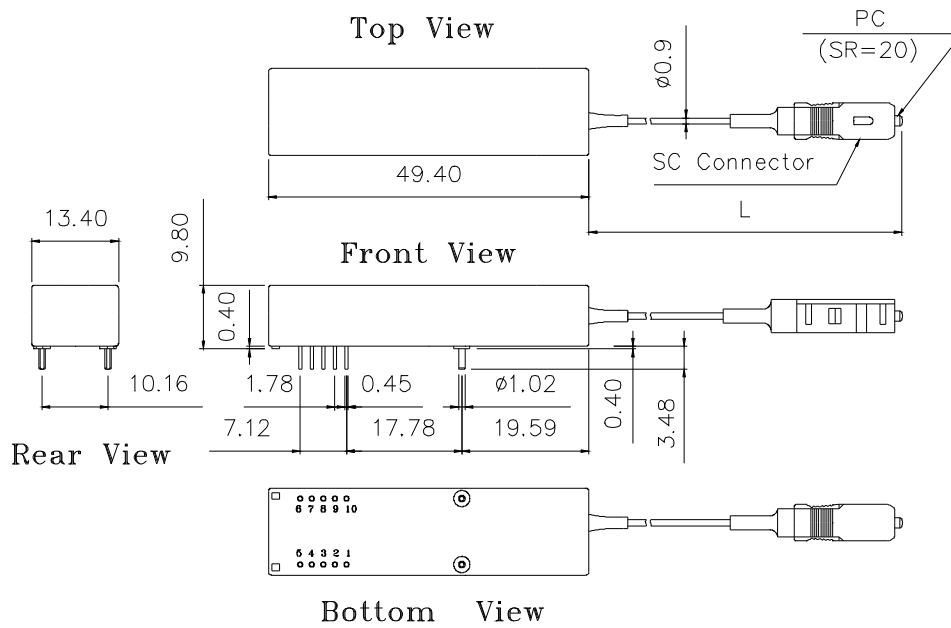

BTRS-7840C-SP50G / BTRS-7840AC-PS50G

Note: Length L is 50 ± 3 cm. Other pigtail's length is available upon request.

Note: Specifications subject to change without notice.