

microSD card connectors CIM-H32N, H52N, H52R

FEATURES

1. Push-in Push-out eject mechanism.
Card eject distance 3.8mm
2. Small and tin design
Normal mount type [CIM-H32N] : H 1.85mm
W 13.7mm Length 16.0mm
Reverse mount type [CIM-H52R] : H 1.85mm
W 14.0mm Length 16.0mm
3. Prevent card jump out of a connector with brake mechanism.
4. Switch With card detection [Normally open type]
5. Prevent card drop from connector with half lock mechanism.

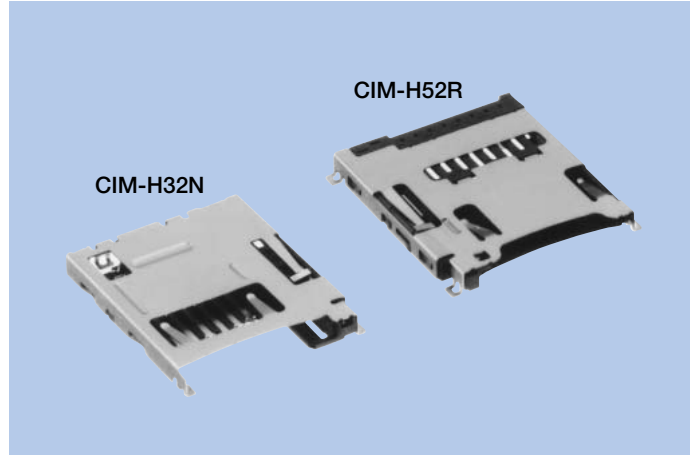

HOW TO ORDER

1. CIM-H32N

H32N-008-21 0 - A G G E
1 2 3 4 5 6 7 8

- 1 Series No. (H32N : Nomal type)
- 2 No. of contacts (008 : 8pins)
- 3 Housing material (21 : LCP resin)
- 4 Housing UL grade (0 : UL94V-0)
- 5 Contact plating (A : Gold)
- 6 Contact plating thickness (G : 3μm)
- 7 Contact read style (G : Angle SMT)
- 8 Package (E : Taping)

2. CIM-H52N

H52N-008-21 0 - A G G E
1 2 3 4 5 6 7 8

- 1 Series No. (H52N : Nomal type) (H52R : Reverse type)
- 2 No. of contacts (008 : 8pins)
- 3 Housing material (21 : LCP resin)
- 4 Housing UL grade (0 : UL94V-0)
- 5 Contact plating (A : Gold)
- 6 Contact plating thickness (G : 3μm)
- 7 Contact read style (G : Angle SMT)
- 8 Package (E : Taping)

SPECIFICATIONS

ELECTRICAL CHARACTERISTICS

Rated Voltage	AC 50V (rms)
Rated Current	0.5A
Withstanding Voltage	500V AC (rms) 1minute
Insulation Resistance	1000MΩ min. (Initial value)
Contact Resistance	100mΩ max. (Initial value)

MECHANICAL CHARACTERISTICS

Life (Matching Cycle)	10,000times
Card Insertion Force	2.0N~6.0N
Eject Force	2.0N~6.0N
Using Temperature Range	-25~+85°C

MATERIAL & FINISH

Component Parts	Material	Finish
Housing	LCP resin	(Black)
Contact	Copper Alloy	Gold plating
CD Switch Vdd	Copper Alloy	Gold plating
CD Switch Vss	Copper Alloy	Gold plating
Plate	Copper Alloy	-
Slider	PA9T resin	(Black)
Half Lock	SUS	-
Coil Spring	SUS	-
Lock Pin	SUS	-

Board installation condition

Normal type (CIM-H32N)

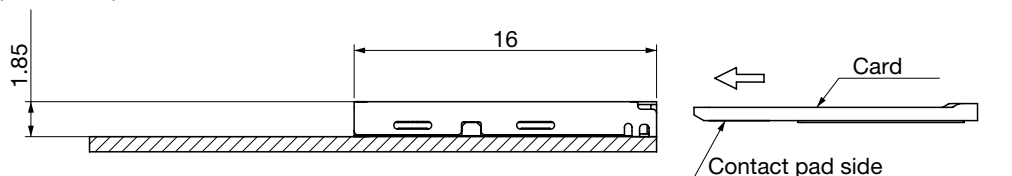

Reverse type (CIM-H52R)

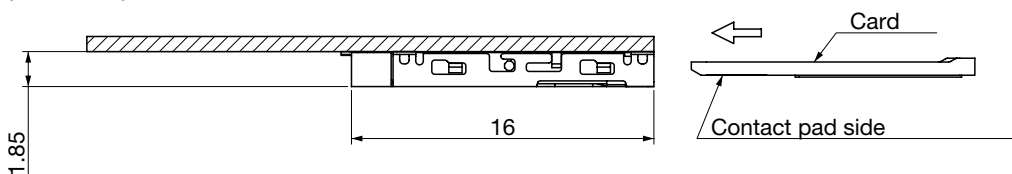

DIMENSIONS

CIM-H32N

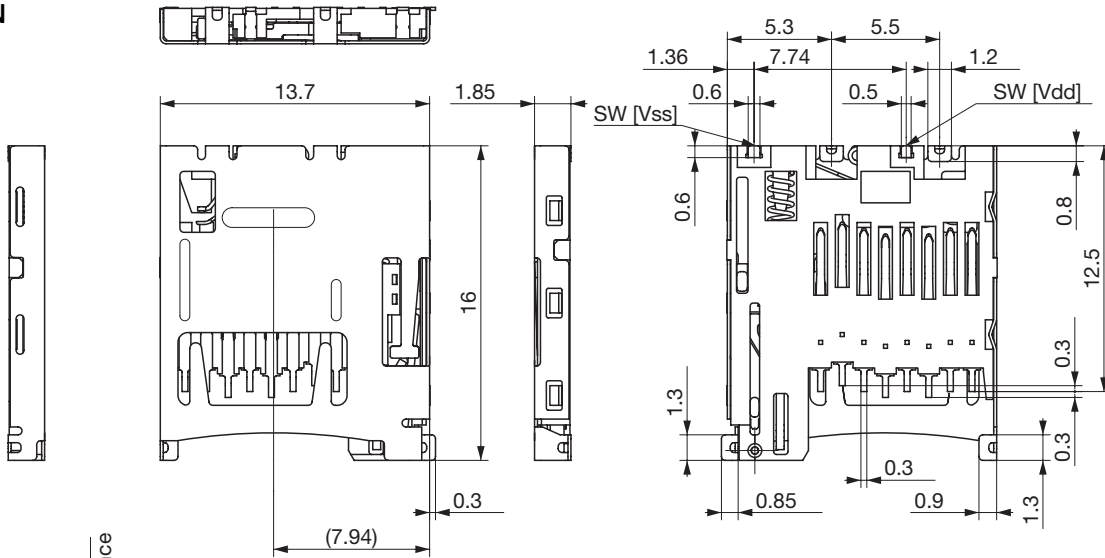

Recommended PWB layout

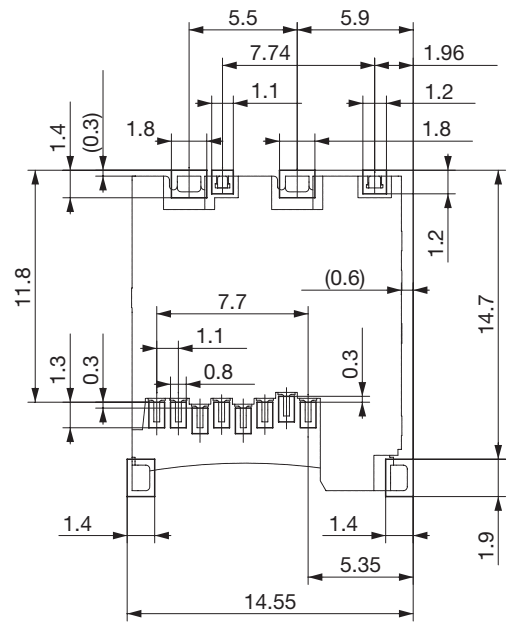

Recommended PWB layout (NTS) ±0.05

Packing specification

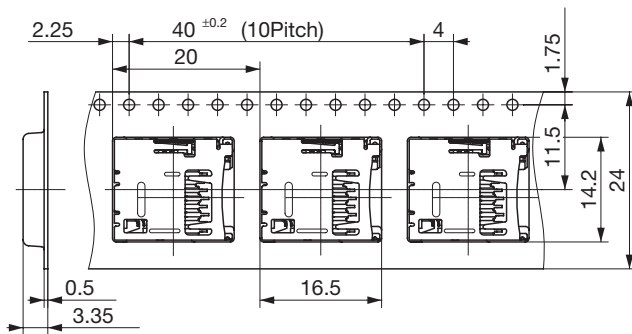

Tiller area

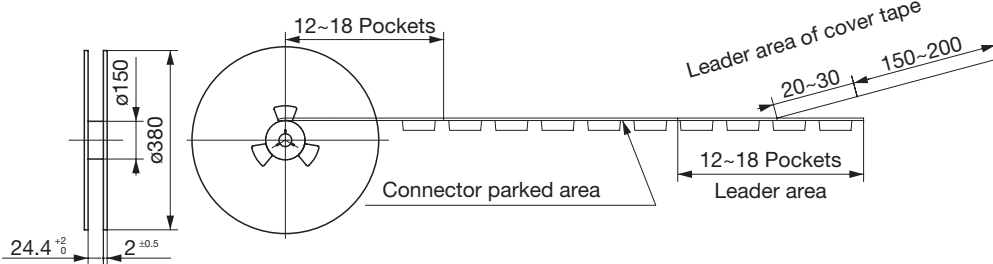

CIM-H52R

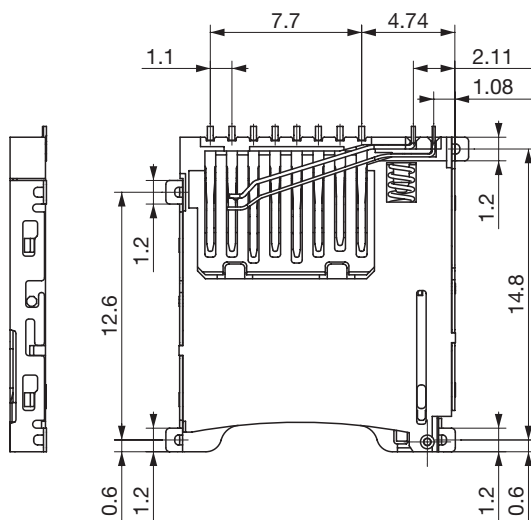
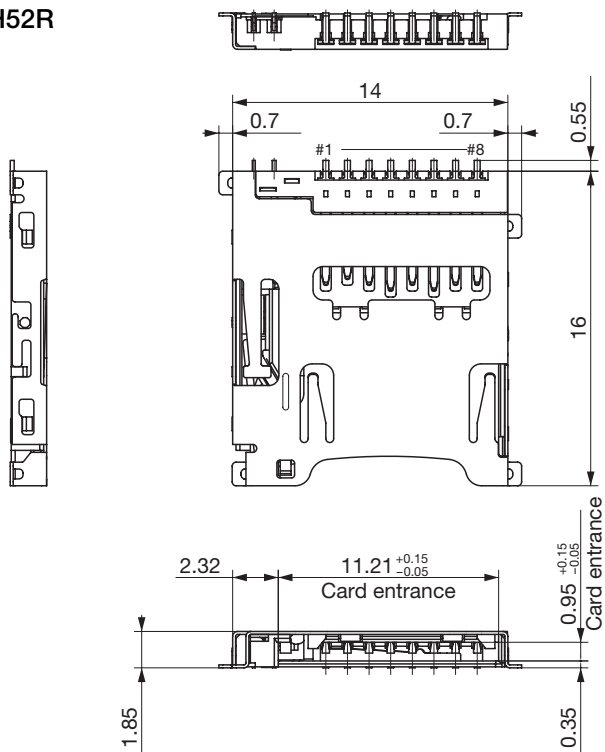

Recommended PWB layout

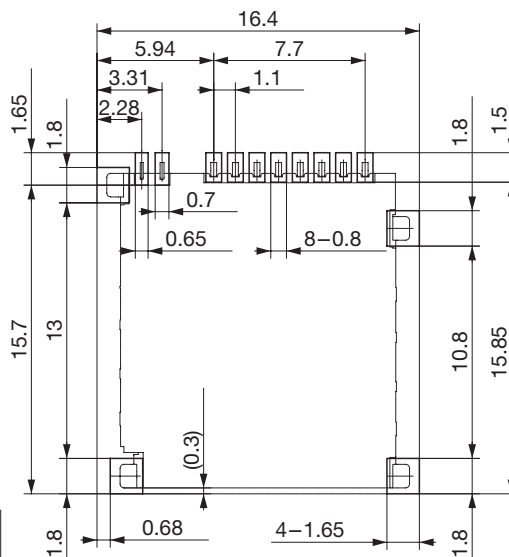

Recommended PWB layout (NTS) ± 0.05

Packing specification

