

MOS INTEGRATED CIRCUIT

μ PD78056F, 78058F

8-BIT SINGLE-CHIP MICROCONTROLLER

DESCRIPTION

The μ PD78056F, 78058F reduce the electromagnetic interference (EMI) noise in comparison with the conventional μ PD78056F, 78058F. The μ PD78056F, 78058F belong to the μ PD78058F Subseries products of the 78K/0 Series. These microcontrollers include a variety of peripheral hardware, such as an 8-bit resolution A/D converter, 8-bit resolution D/A converter, timer, serial interface, real-time output ports, and interrupt functions.

The μ PD78P058FY, a one-time PROM which can be operated in the same supply voltage range as for the mask ROM version, and various development tools are also available.

Detailed function descriptions are provided in the following user's manual. Be sure to read them before designing.

μ PD78058F, 78058FY Subseries User's Manual: U12068E
78K/0 Series User's Manual-Instruction: U12326E

FEATURES

- EMI noise reduction version (The overall peak level is reduced by 5 to 10 dB.)
- Large on-chip ROM & RAM

Items Products	Program Memory (ROM)	Data Memory			Packages
		Internal High-Speed RAM	Buffer RAM	Internal Expansion RAM	
μ PD78056F	48 Kbytes	1024 bytes	32 bytes	None	80-pin plastic QFP (14 × 14 mm, resin thickness 2.7 mm) 80-pin plastic QFP (14 × 14 mm, resin thickness 1.4 mm) 80-pin plastic TQFP (fine pitch) (12 × 12 mm) ^{Note}
μ PD78058F	60 Kbytes			1024 bytes	

Note This package is available only for the μ PD78058F.

- External memory expansion space: 64 Kbytes
- Minimum instruction execution time can be varied from high-speed (0.4 μ s) to ultra-low-speed (122 μ s)
- I/O ports: 69 (N-ch open-drain: 4)
- 8-bit resolution A/D converter: 8 channels
- 8-bit resolution D/A converter: 2 channels
- Serial interface: 3 channels
- Timer: 5 channels
- Supply voltage: $V_{DD} = 2.7$ to 6.0 V

APPLICATIONS

Cellular phones, pagers, printers, AV equipment, air conditioners, cameras, PPC, fuzzy home appliances, vending machines, etc.

The information in this document is subject to change without notice.

ORDERING INFORMATION

Part Number	Package
μPD78056FGC-xxx-3B9	80-pin plastic QFP (14 × 14 mm, resin thickness 2.7 mm)
★ μPD78056FGC-xxx-8BT	80-pin plastic QFP (14 × 14 mm, resin thickness 1.4 mm)
μPD78058FGC-xxx-3B9	80-pin plastic QFP (14 × 14 mm, resin thickness 2.7 mm)
★ μPD78058FGC-xxx-8BT	80-pin plastic QFP (14 × 14 mm, resin thickness 1.4 mm)
μPD78058FGK-xxx-BE9	80-pin plastic TQFP (fine pitch) (12 × 12 mm)

Caution The μPD78056FGC, μPD78058FGC come in two types of packages (see 12 Package Drawings). For the packages that can be supplied, consult your local NEC sales representative.

Remark xxx denotes the ROM code number.

★ 78K/0 SERIES PRODUCT DEVELOPMENT

These products are a further development in the 78K/0 Series. The designations appearing inside the boxes are subseries names.

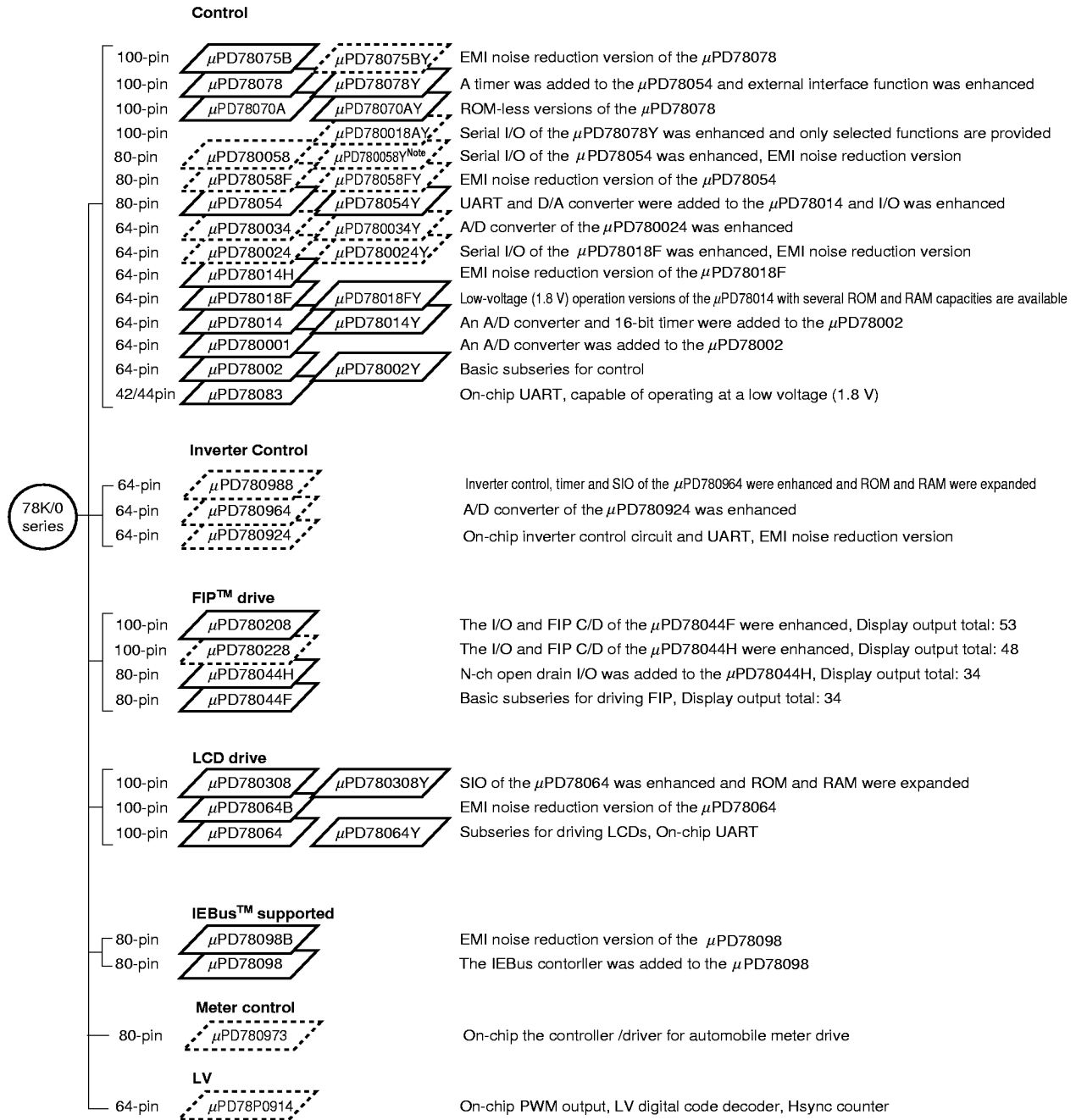
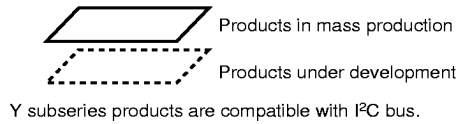

Note Under planning

The major functional differences among the subseries are shown below.

Subseries	Function	ROM Capacity	Timer				8-bit A/D	10-bit A/D	8-bit D/A	Serial Interface	I/O	V _{DD} MIN. Value	External Expansion								
			8-bit	16-bit	Watch	WDT															
Control	μPD78075B	32 K-40 K	4ch	1ch	1ch	1ch	8ch	—	2ch	3ch (UART: 1ch)	88	1.8 V	Available								
	μPD78078	48 K-60 K									61	2.7 V									
	μPD78070A	—									61	2.7 V									
	μPD780058	24 K-60 K	2ch	—	—	—	—	8ch	—	3ch (time-division UART: 1ch)	68	1.8 V									
	μPD78058F	48 K-60 K								3ch (UART: 1ch)	69	2.7 V									
	μPD78054	16 K-60 K								2.0 V											
	μPD780034	8 K-32 K								3ch (UART: 1ch, time-division 3-wire : 1ch)	51	1.8 V									
	μPD780024									2ch	53	2.7 V									
	μPD78014H	8 K-60 K								1ch	—	—		—	8ch	—	—	1ch	39	2.7 V	
	μPD78018F																		53		Available
	μPD78014																		8 K-32 K		
	μPD780001	8 K								—	—	—		—	—	—	—	1ch	39	2.7 V	
	μPD780002	8 K-16 K																	53		Available
μPD78083	8 K	33	1.8 V	—																	
Inverter control	μPD780988	32 K-60 K	3ch	Note 1	—	1ch	—	8ch	—	3ch (UART: 2ch)	47	4.0 V	Available								
	μPD780964	8 K-32 K		Note 2						2ch (UART : 2ch)	2.7 V										
	μPD780924	8 K-32 K		8ch						—											
FIP drive	μPD780208	32 K-60 K	2ch	1ch	1ch	1ch	8ch	—	—	2ch	74	2.7 V	—								
	μPD780228	48 K-60 K								1ch	72	4.5 V									
	μPD78044H	32 K-48 K								1ch	68	2.7 V									
	μPD78044F	16 K-40 K								2 ch											
LCD drive	μPD780308	48 K-60 K	2ch	1ch	1ch	1ch	8ch	—	—	3ch (time-division UART: 1ch)	57	2.0 V	—								
	μPD78064B	32 K								2ch (UART: 1ch)											
	μPD78064	16 K-32 K																			
IEBus supported	μPD78098B	40 K-60 K	2ch	1ch	1ch	1ch	8ch	—	2ch	3ch (UART: 1ch)	69	2.7 V	Available								
	μPD78098	32 K-60 K																			
Meter control	μPD780973	24 K-32 K	3ch	1ch	1ch	1ch	5ch	—	—	2ch (UAR: 1ch)	56	4.5 V	—								
LV	μPD78P0914	32 K	6ch	—	—	1ch	8ch	—	—	2ch	54	4.5 V	Available								

- Notes**
- 16-bit timer : 2 channel
10-bit timer : 1 channel
 - 10-bit timer : 1 channel

OVERVIEW OF FUNCTION

Item		Product Name	μPD78056F	μPD78058F
Internal memory	ROM		48 Kbytes	60 Kbytes
	High-speed RAM		1024 bytes	
	Buffer RAM		32 bytes	
	Expanded RAM		None	1024 Kbytes
Memory space			64 Kbytes	
General registers			8 bits × 32 registers (8 bits × 8 registers × 4 banks)	
Minimum instruction execution time			On-chip instruction execution time cycle modification function	
	When main system clock selected		0.4 μs/0.8 μs/1.6 μs/3.2 μs/6.4 μs/12.8 μs (at 5.0-MHz operation)	
	When subsystem clock selected		122 μs (at 32.768-kHz operation)	
Instruction set			<ul style="list-style-type: none"> • 16-bit operation • Multiplication/division (8 bits × 8 bits, 16 bits ÷ 8 bits) • Bit manipulation (set, reset, test, Boolean operation) • BCD correction, etc. 	
I/O ports			Total : 69 <ul style="list-style-type: none"> • CMOS input : 2 • CMOS I/O : 63 • N-ch open-drain I/O : 4 	
A/D converter			• 8-bit resolution × 8 channels	
D/A converter			• 8-bit resolution × 2 channels	
Serial interface			<ul style="list-style-type: none"> • 3-wire serial I/O/SBI/2-wire serial I/O/I²C bus mode selectable: 1 channel • 3-wire serial I/O mode (on-chip max. 32 bytes automatic data transmit/receive function): 1 channel • 3-wire serial I/O/UART mode selectable: 1 channel 	
Timer			<ul style="list-style-type: none"> • 16-bit timer/event counter : 1 channel • 8-bit timer/event counter : 2 channels • Watch timer : 1 channel • Watchdog timer : 1 channel 	
Timer output			3 (14-bit PWM output × 1)	
Clock output			19.5 kHz, 39.1 kHz, 78.1 kHz, 156 kHz, 313 kHz, 625 kHz, 1.25 MHz, 2.5 MHz, 5.0 MHz (main system clock: at 5.0-MHz operation) 32.768 kHz (subsystem clock: at 32.768-kHz operation)	
Buzzer output			1.2 kHz, 2.4 kHz, 4.9 kHz, 9.8 kHz (main system clock: at 5.0-MHz operation)	
Vectored-interrupt source	Maskable		Internal : 13, external : 7	
	Non-maskable		Internal : 1	
	Software		1	
Test input			Internal : 1, external : 1	
Supply voltage			V _{DD} = 2.7 to 6.0 V	
Operating ambient temperature			T _A = - 40 to + 85°C	
Package			<ul style="list-style-type: none"> • 80-pin plastic QFP (14 × 14 mm, resin thickness 2.7 mm) • 80-pin plastic QFP (14 × 14 mm, resin thickness 1.4 mm) • 80-pin plastic TQFP (fine pitch) (12 × 12 mm) Note 	

Note μPD78058F only

CONTENTS

1. PIN CONFIGURATION (TOP VIEW)	7
2. BLOCK DIAGRAM	9
3. PIN FUNCTIONS	10
3.1 Port Pins	10
3.2 Non-port Pins	12
3.3 Pin I/O Circuits and Recommended Connection of Unused Pins	14
4. MEMORY SPACE	18
5. PERIPHERAL HARDWARE FUNCTION FEATURES	19
5.1 Ports	19
5.2 Clock Generator	20
5.3 Timer/Event Counter	20
5.4 Clock Output Control Circuit	23
5.5 Buzzer Output Control Circuit	23
5.6 A/D Converter	24
5.7 D/A Converter	25
5.8 Serial Interfaces	25
5.9 Real-Time Output Port Functions	27
6. INTERRUPT FUNCTIONS AND TEST FUNCTIONS	28
6.1 Interrupt Functions	28
6.2 Test Functions	32
7. EXTERNAL DEVICE EXPANSION FUNCTIONS	33
8. STANDBY FUNCTION	33
9. RESET FUNCTION	33
10. INSTRUCTION SET	34
11. ELECTRICAL SPECIFICATIONS	37
12. PACKAGE DRAWINGS	63
13. RECOMMENDED SOLDERING CONDITIONS	66
APPENDIX A. DEVELOPMENT TOOLS	68
APPENDIX B. RELATED DOCUMENTS	70

1. PIN CONFIGURATION (TOP VIEW)

- 80-pin plastic QFP (14 × 14, resin thickness 2.7 mm)

μPD78056FGC-xxx-3B9

μPD78058FGC-xxx-3B9

- 80-pin plastic TQFP (fine pitch) (12 × 12 mm)

μPD78058FGK-xxx-BE9

- 80-pin plastic QFP (14 × 14, resign thickness 1.4 mm)

μPD78056FGC-xxx-8BT

μPD78058FGC-xxx-8BT

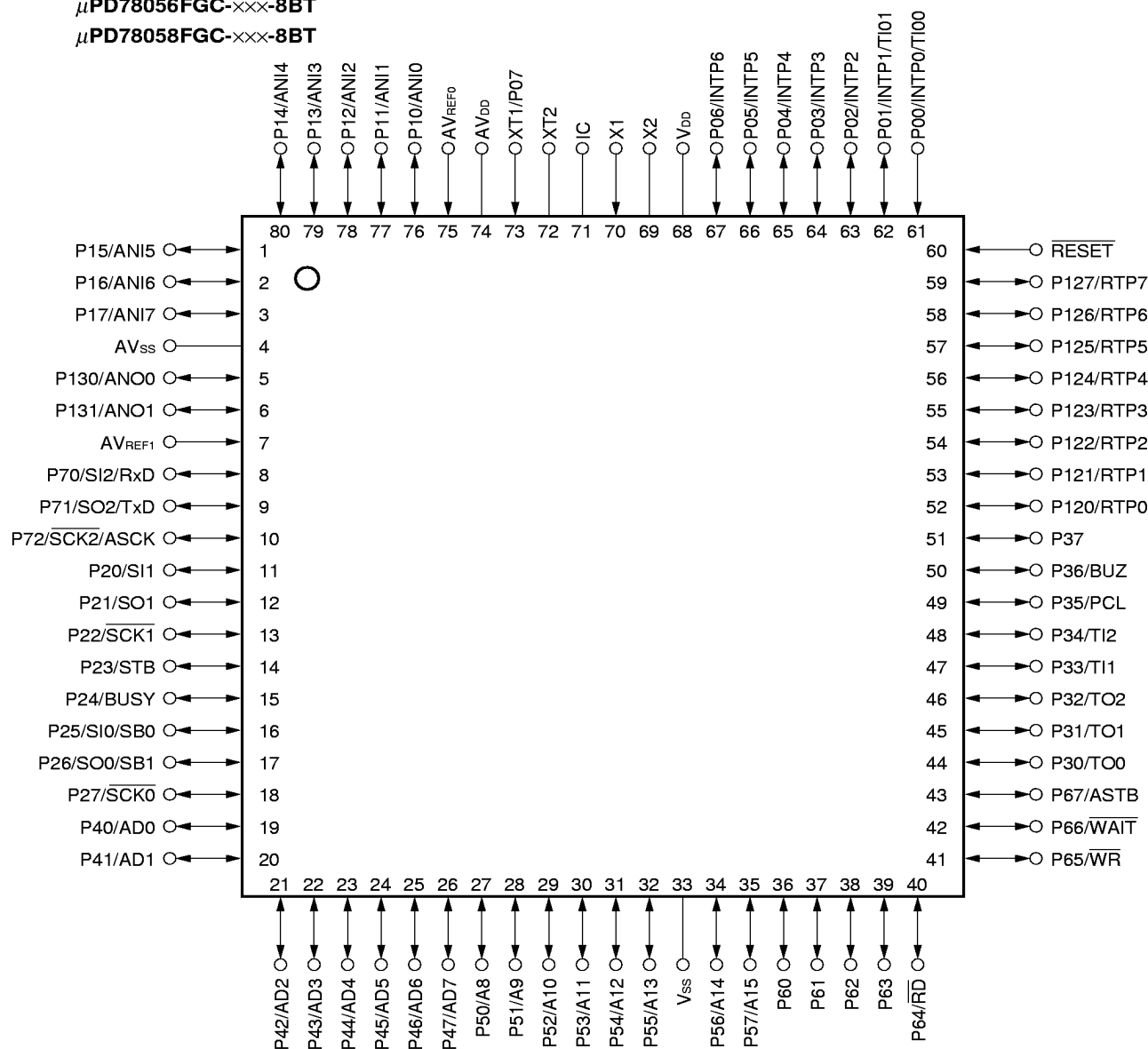

- Cautions**
1. Connect directly the Internally Connected (IC) pin to V_{ss}.
 2. The AV_{DD} pin functions as both an A/D converter power supply and a port power supply. When the μPD78056F and 78058F are used in applications where the noise generated inside the microcontroller needs to be reduced, connect the AV_{DD} pin to another power supply which has the same potential as V_{DD}.
 3. The AV_{SS} pin functions as both an A/D and D/A converter ground and as a port ground. When the μPD78056F and 78058F are used in applications where the noise generated inside the microcontroller needs to be reduced, connect the AV_{SS} pin to a ground line other than V_{SS}.

A8 to A15	: Address Bus	P130, P131	: Port13
AD0 to AD7	: Address/Data Bus	PCL	: Programmable Clock
ANI0 to ANI7	: Analog Input	<u>RD</u>	: Read Strobe
ANO0, ANO1	: Analog Output	RESET	: Reset
ASCK	: Asynchronous Serial Clock	RTP0 to RTP7	: Real-Time Output Port
ASTB	: Address Strobe	RxD	: Receive Data
AV _{DD}	: Analog Power Supply	<u>SB0, SB1</u>	: Serial Bus
AV _{REF0} , AV _{REF1}	: Analog Reference Voltage	<u>SCK0 to SCK2</u>	: Serial Clock
AV _{SS}	: Analog Ground	SI0 to SI2	: Serial Input
BUSY	: Busy	SO0 to SO2	: Serial Output
BUZ	: Buzzer Clock	STB	: Strobe
IC	: Internally Connected	TI00, TI01	: Timer Input
INTP0 to INTP6	: Interrupt from Peripherals	TI1, TI2,	: Timer Input
P00 to P07	: Port0	TO0 to TO2	: Timer Output
P10 to P17	: Port1	TxD	: Transmit Data
P20 to P27	: Port2	V _{DD}	: Power Supply
P30 to P37	: Port3	V _{SS}	: Ground
P40 to P47	: Port4	<u>WAIT</u>	: Wait
P50 to P57	: Port5	<u>WR</u>	: Write Strobe
P60 to P67	: Port6	X1, X2	: Crystal (Main System Clock)
P70 to P72	: Port7	XT1, XT2	: Crystal (Subsystem Clock)
P120 to P127	: Port12		

2. BLOCK DIAGRAM

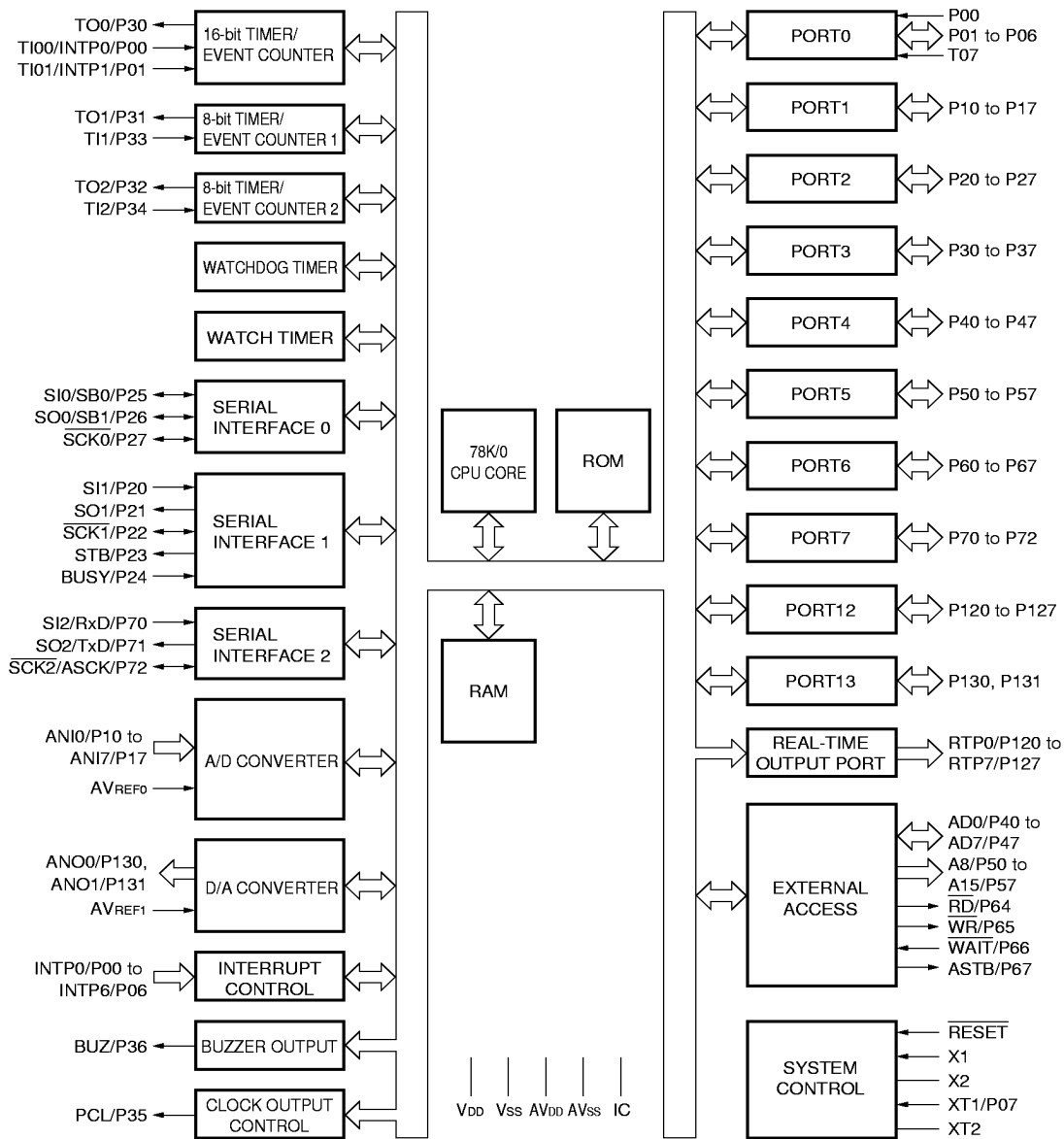

Remark The internal ROM and RAM capacity depends on the product.

3. PIN FUNCTIONS

3.1 Port Pins (1/2)

Pin Name	I/O	Function		After Reset	Alternate Function
P00	Input	Port 0 8-bit I/O port	Input only	Input	INTP0/TI00
P01	Input/ output		Input/output can be specified bit-wise. When used as an input port, on-chip pull-up resistor can be used by software.	Input	INTP1/TI01
P02					INTP2
P03					INTP3
P04					INTP4
P05					INTP5
P06					INTP6
P07 Note 1	Input		Input only	Input	XT1
P10 to P17	Input/ output	Port 1 8-bit input/output port. Input/output can be specified bit-wise. When used as an input port, on-chip pull-up resistor can be used by software. Note 2		Input	ANI0 to ANI7
P20	Input/ output	Port 2 8-bit input/output port. Input/output can be specified bit-wise. When used as an input port, on-chip pull-up resistor can be used by software.	Input	S11	
P21				SO1	
P22				$\overline{\text{SCK1}}$	
P23				STB	
P24				BUSY	
P25				SI0/SB0	
P26				SO0/SB1	
P27				$\overline{\text{SCK0}}$	
P30	Input/ output	Port 3 8-bit input/output port. Input/output can be specified bit-wise. When used as an input port, on-chip pull-up resistor can be used by software.	Input	TO0	
P31				TO1	
P32				TO2	
P33				TI1	
P34				TI2	
P35				PCL	
P36				BUZ	
P37				—	
P40 to P47	Input/ output	Port 4 8-bit input/output port. Input/output can be specified in 8-bit unit. When used as an input port, on-chip pull-up resistor can be used by software. Test input flag (KRIF) is set to 1 by falling edge detection.		Input	AD0 to AD7

- Notes**
1. When using the P07/XT1 pins as an input port, set 1 in bit 6 (FRC) of the processor clock control register. On-chip feedback resistor of the subsystem clock oscillator should not be used.
 2. When using the P10/ANI0 to P17/ANI7 pins as the A/D converter analog input pins, use of the on-chip pull-up resistor is cancelled automatically.

3.1 Port Pins (2/2)

Pin Name	I/O	Function		After Reset	Alternate Function
P50 to P57	Input/output	Port 5 8-bit input/output port. LED can be driven directly. Input/output can be specified bit-wise. When used as an input port, on-chip pull-up resistor can be used by software.		Input	A8 to A15
P60	Input/output	Port 6 8-bit input/output port. Input/output can be specified bit-wise.	N-ch open-drain input/output port. On-chip pull-up resistor can be specified by mask option. LED can be driven directly.	Input	—
P61					
P62					
P63					
P64			When used as an input port, on-chip pull-up resistor can be used by software.	Input	\overline{RD}
P65					\overline{WR}
P66					\overline{WAIT}
P67					ASTB
P70	Input/output	Port 7 3-bit input/output port. Input/output can be specified bit-wise. When used as an input port, on-chip pull-up resistor can be used by software.	Input	$\overline{SI2/RxD}$	
P71				$\overline{SO2/TxD}$	
P72				$\overline{SCK2/ASCK}$	
P120 to P127	Input/output	Port 12 8-bit input/output port. Input/output can be specified bit-wise. When used as an input port, on-chip pull-up resistor can be used by software.		Input	RTP0 to RTP7
P130, P131	Input/output	Port 13 2-bit input/output port. Input/output can be specified bit-wise. When used as an input port, on-chip pull-up resistor can be used by software.		Input	ANO0, ANO1

Caution For pins which also function as port pins, do not perform the following operations during A/D conversion. If these operations are performed, the total error ratings cannot be kept (except for LCD segment output alternate-function pin).

- (1) Rewrite the output latch which the pin is used as a port pin.
- (2) Change the output level of the pin used as an output pin, even if it is not used as a port pin.

3.2 Non-port Pins (1/2)

Pin Name	I/O	Function	After Reset	Alternate Function
INTP0	Input	External interrupt request input by which the effective edge (rising edge, falling edge, or both rising edge and falling edge) can be specified.	Input	P00/TI00
INTP1				P01/TI01
INTP2				P02
INTP3				P03
INTP4				P04
INTP5				P05
INTP6				P06
SI0	Input	Serial interface serial data input.	Input	P25/SB0
SI1				P20
SI2				P70/RxD
SO0	Output	Serial interface serial data output.	Input	P26/SB1
SO1				P21
SO2				P71/TxD
SB0	Input /output	Serial interface serial data input/output.	Input	P25/SI0
SB1				P26/SO0
SDA0				P25/SI0
SDA1				P26/SO0
$\overline{\text{SCK0}}$	Input /output	Serial interface serial clock input/ output	Input	P27
$\overline{\text{SCK1}}$				P22
$\overline{\text{SCK2}}$				P72/ASCK
STB	Output	Serial interface automatic transmit/receive strobe output.	Input	P23
BUSY	Input	Serial interface automatic transmit/receive busy input.	Input	P24
RxD	Input	Asynchronous serial interface serial data input.	Input	P70/SI2
TxD	Output	Asynchronous serial interface serial data output.	Input	P71/SO2
ASCK	Input	Asynchronous serial interface serial clock input.	Input	P72/ $\overline{\text{SCK2}}$
TI00	Input	External count clock input to the 16-bit timer (TM0)	Input	P00/INTP0
TI01		Capture trigger signal input to the capture register (CR00)		P01/INTP1
TI1		External count clock input to the 8-bit timer (TM1)		P33
TI2		External count clock input to the 8-bit timer (TM2)		P34
TO0	Output	16-bit timer (TM0) output (alternate function as 14-bit PWM output)	Input	P30
TO1		8-bit timer (TM1) output		P31
TO2		8-bit timer (TM2)		P32
PCL	Output	Clock output (for main system clock, subsystem clock trimming).	Input	P35
BUZ	Output	Buzzer output.	Input	P36
RTP0 to RTP7	Output	Real-time output port by which data is output in synchronization with a trigger.	Input	P120 to P127
AD0 to AD7	Input /output	Low-order address/data bus at external memory expansion.	Input	P40 to P47

3.2 Non-port Pins (2/2)

Pin Name	I/O	Function	After Reset	Alternate Function
A8 to A15	Output	High-order address bus at external memory expansion.	Input	P50 to P57
\overline{RD}	Output	External memory read operation strobe signal output.	Input	P64
\overline{WR}		External memory write operation strobe signal output.		P65
\overline{WAIT}	Input	Wait insertion at external memory access.	Input	P66
ASTB	Output	Strobe output which latches the address information output at port 4 to access external memory.	Input	P67
ANI0 to ANI7	Input	A/D converter analog input.	Input	P10 to P17
ANO0, ANO1	Output	D/A converter analog output.	Input	P130, P131
AVREF0	Input	A/D converter reference voltage input.	—	—
AVREF1	Input	D/A converter reference voltage input.	—	—
AVDD	—	A/D converter analog power supply (shared with the port power supply)	—	—
AVSS	—	A/D and D/A converter ground potential (shared with the port ground potential)	—	—
\overline{RESET}	Input	System reset input.	—	—
X1	Input	Main system clock oscillation crystal connection.	—	—
X2	—		—	—
XT1	Input	Subsystem clock oscillation crystal connection.	Input	P07
XT2	—		—	—
VDD	—	Positive power supply (except for port).	—	—
VSS	—	Ground potential (except for port).	—	—
IC	—	Internally connected. Connect directly to V _{SS} .	—	—

- Cautions**
1. The AV_{DD} pin functions as both an A/D converter power supply and a port power supply. When the μPD78056F and 78058F are used in applications where the noise generated inside the microcontroller needs to be reduced, connect the AV_{DD} pin to another power supply which has the same potential as V_{DD}.
 2. The AV_{SS} pin functions as both an A/D converter and D/A converter ground and as a port ground. When the μPD78056F and 78058F are used in applications where the noise generated inside the microcontroller needs to be reduced, connect the AV_{SS} pin to a ground line other than V_{SS}.

3.3 Pin I/O Circuits and Recommended Connection of Unused Pins

The input/output circuit type of each pin and recommended connection of unused pins are shown in Table 3-1. For the input/output circuit configuration of each type, see Figure 3-1.

Table 3-1. Input/Output Circuit Type of Each Pin (1/2)

Pin Name	Input/output Circuit Type	I/O	Recommended Connection when not Used	
P00/INTP0/TI00	2	Input	Connect to V _{SS} .	
P01/INTP1/TI01	8-D	Input/output	Independently connect to V _{SS} through resistor.	
P02/INTP2				
P03/INTP3				
P04/INTP4				
P05/INTP5				
P06/INTP6				
P07/XT1				16
P10/ANI0 to P17/ANI7	11-C	Input/output	Independently connect to V _{DD} or V _{SS} through resistor.	
P20/SI1	8-D			
P21/SO1	5-J			
P22/SCK1	8-D			
P23/STB	5-J			
P24/BUSY	8-D			
P25/SI0/SB0	10-C			
P26/SO0/SB1				
P27/SCK0				
P30/TO0	5-J			
P31/TO1				
P32/TO2				
P33/TI1	8-D			
P34/TI2				
P35/PCL	5-J			
P36/BUZ				
P37				
P40/AD0 to P47/AD7	5-O			Independently connect to V _{DD} through resistor.
P50/A8 to P57/A15	5-J			Independently connect to V _{DD} or V _{SS} through resistor.
P60 to P63	13-I			Independently connect to V _{DD} through resistor.
P64/RD	5-J			Independently connect to V _{DD} or V _{SS} through resistor.
P65/WR				
P66/WAIT				
P67/ASTB				

Table 3-1. Input/Output Circuit Type of Each Pin (2/2)

Pin Name	Input/output Circuit Type	I/O	Recommended Connection when not Used
P70/SI2/RxD	8-D	Input/ output	Independently connect to V _{DD} or V _{SS} through resistor.
P71/SO2/TxD	5-J		
P72/ $\overline{\text{SCK2}}$ /ASCK	8-D		
P120/RTP0 to P127/RTP7	5-J		
P130/ANO0 , P131/ANO1	12-B		Independently connect to V _{SS} through resistor.
$\overline{\text{RESET}}$	2	Input	—
XT2	16	—	Leave open.
AV _{REF0}	—		Connect to V _{SS} .
AV _{REF1}			Connect to V _{DD} .
AV _{DD}			Connect to another power supply which has the same potential as V _{DD} .
AV _{SS}			Connect to another ground line which has the same potential as V _{SS} .
IC			Connect directly to V _{SS} .

Figure 3-1. Pin Input/Output Circuits (1/2)

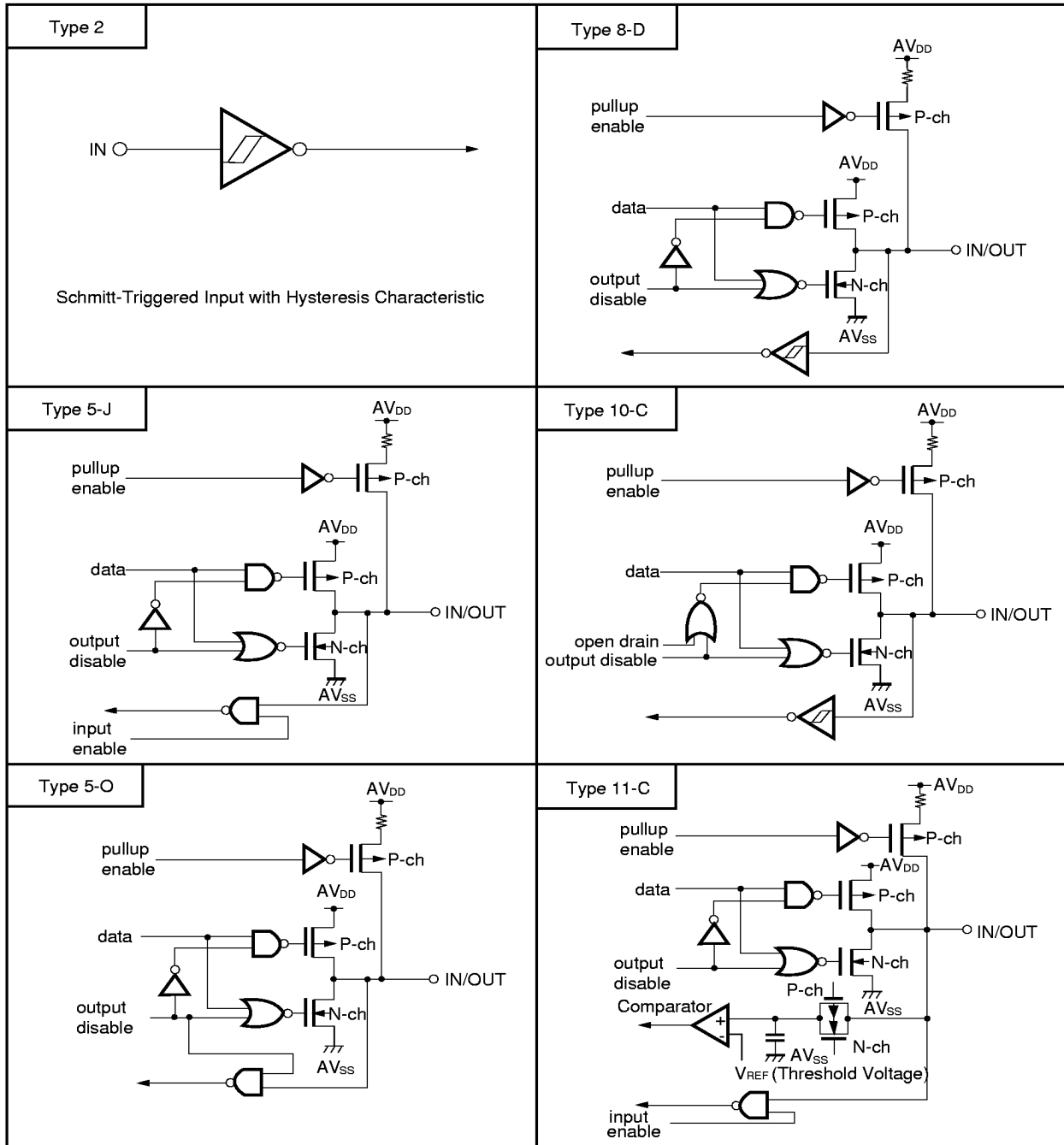
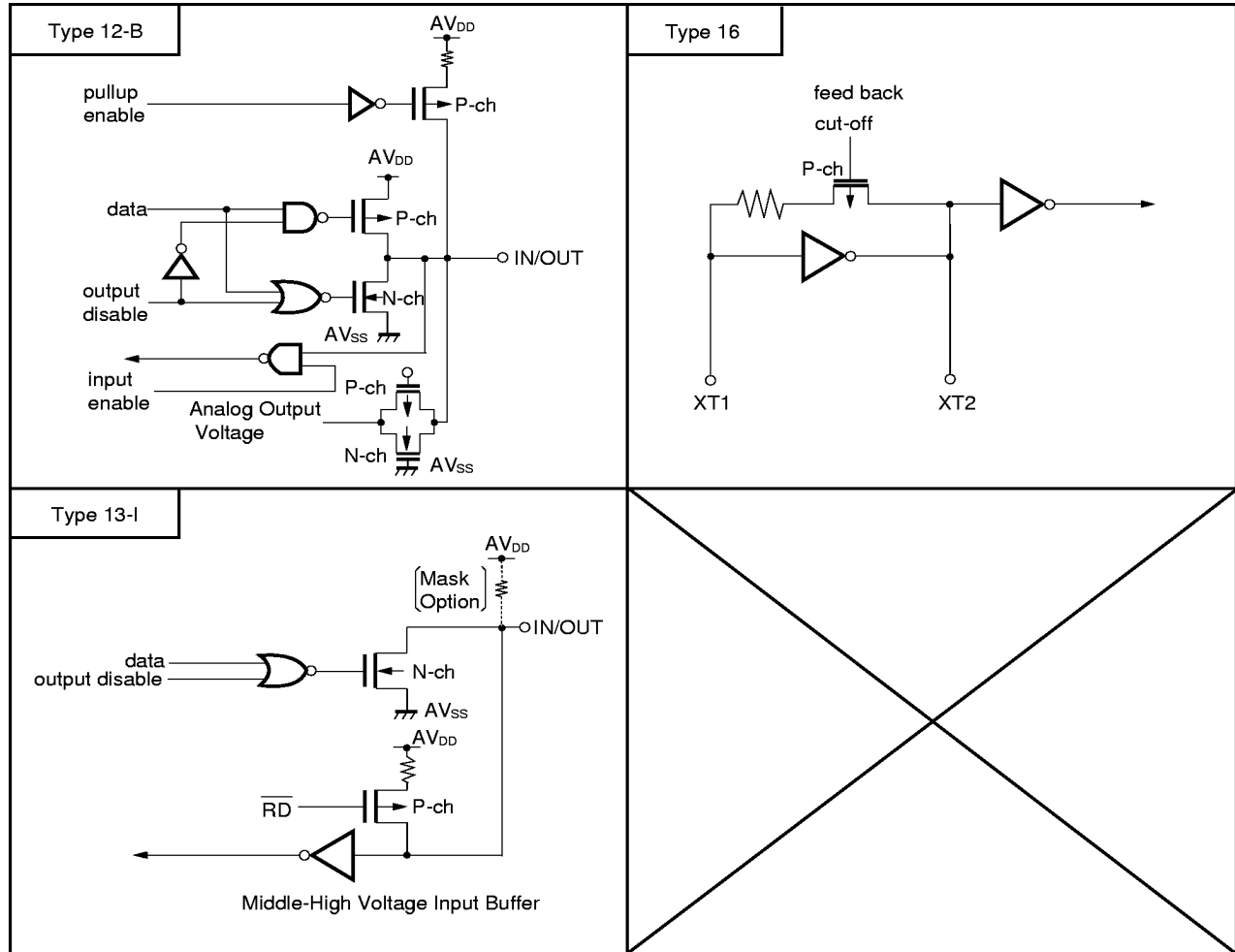

Figure 3-1. Pin Input/Output Circuits (2/2)



4. MEMORY SPACE

Figure 4-1 shows the memory map of the μPD78056F,78058F.

Figure 4-1. Memory Map

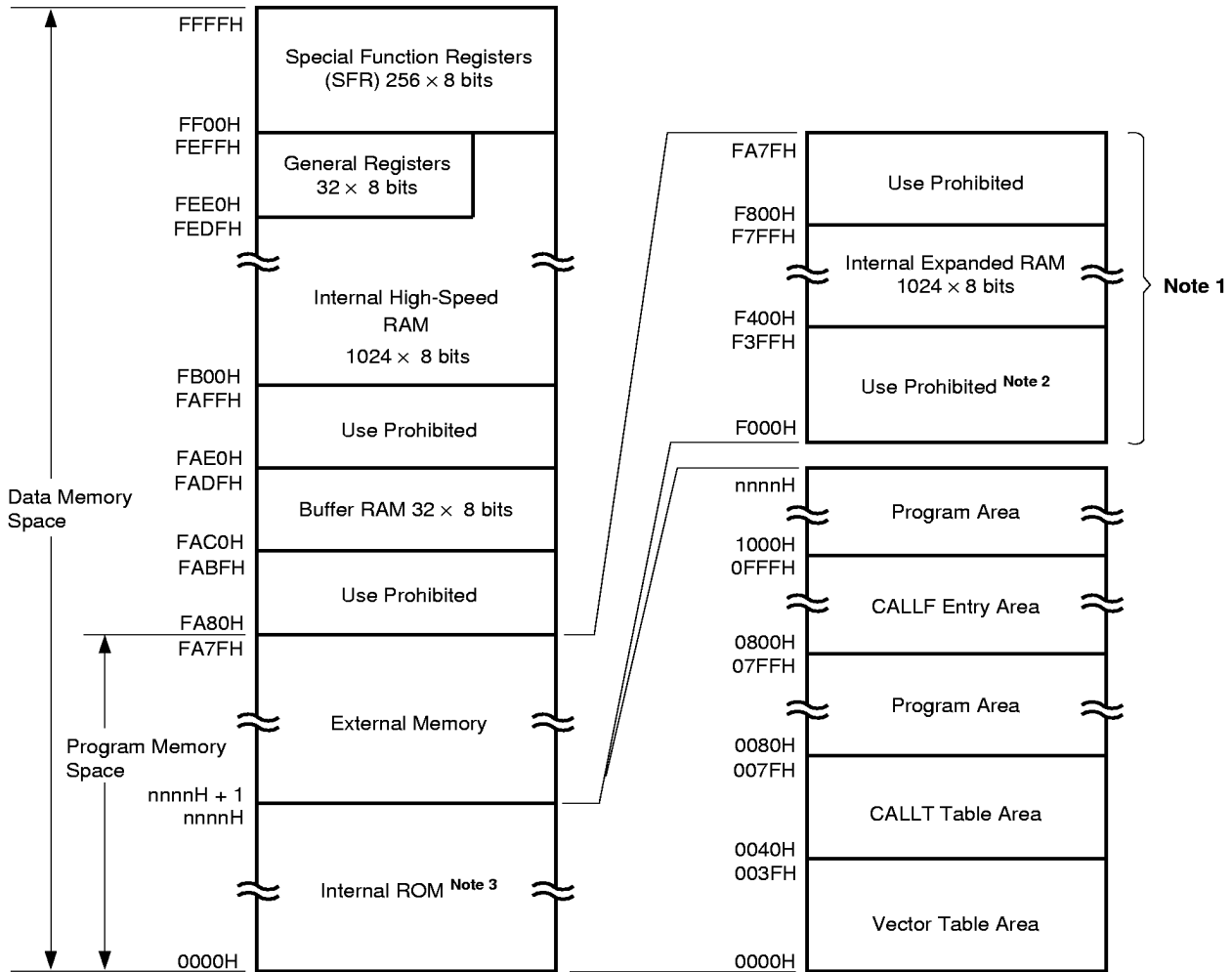

Notes 1. μPD78058F only

- 2. When the external device expansion function is used with the μPD78058F, set the internal ROM capacity to 56 Kbytes or less using the memory size switching register (IMS).
- 3. The internal ROM capacity and internal high-speed RAM capacity depend on the products (see the table below).

Target Product	Internal ROM Last Address nnnnH
μPD78056F	BFFFH
μPD78058F	EFFFH

5. PERIPHERAL HARDWARE FUNCTION FEATURES

5.1 Ports

The following 3 types of I/O ports are available.

• CMOS input (P00, P07)	: 2
• CMOS input/output (P01 to P06, port 1 to port 5, P64 to P67, port 7, port 12, port 13)	: 63
• N-ch open-drain input/output (P60 to P63)	: 4
Total	: 69

Table 5-1. Port Functions

Name	Pin Name	Function
Port 0	P00, P07	Dedicated input port pins
	P01 to P06	Input/output port pins. Input/output specifiable bit-wise. When used as input/output port pins, on-chip pull-up resistor can be used by software.
Port 1	P10 to P17	Input/output port pins. Input/output specifiable bit-wise. When used as input port pins, on-chip pull-up resistor can be used by software.
Port 2	P20 to P27	Input/output port pins. Input/output specifiable bit-wise. When used as input port pins, on-chip pull-up resistor can be used by software.
Port 3	P30 to P37	Input/output port pins. Input/output specifiable bit-wise. When used as input port pins, on-chip pull-up resistor can be used by software.
Port 4	P40 to P47	Input/output port pins. Input/output specifiable in 8-bit units. When used as input port pins, on-chip pull-up resistor can be used by software. Test input flag (KRIF) is set to 1 by falling edge detection.
Port 5	P50 to P57	Input/output port pins. Input/output specifiable bit-wise. When used as input port pins, on-chip pull-up resistor can be used by software. LED direct drive capability.
Port 6	P60 to P63	N-channel open-drain input/output port pins. Input/output specifiable bit-wise. On-chip pull-up resistor can be used by mask option. LED direct drive capability.
	P64 to P67	Input/output port pins. Input/output specifiable bit-wise. When used as input/output port pins, on-chip pull-up resistor can be used by software.
Port 7	P70 to P72	Input/output port pins. Input/output specifiable bit-wise. When used as input/output port pins, on-chip pull-up resistor can be used by software.
Port 12	P120 to P127	Input/output port pins. Input/output specifiable bit-wise. When used as input/output port pins, on-chip pull-up resistor can be used by software.
Port 13	P130, P131	Input/output port pins. Input/output specifiable bit-wise. When used as input/output port pins, on-chip pull-up resistor can be used by software.

5.2 Clock Generator

Two types of generators, a main system clock generator and a subsystem clock generator, are available. The minimum instruction execution time can also be changed.

- 0.4 μs/0.8 μs/1.6 μs/3.2 μs/6.4 μs/12.8 μs (main system clock: at 5.0-MHz operation)
- 122 μs (subsystem clock: at 32.768-kHz operation)

Figure 5-1. Clock Generator Block Diagram

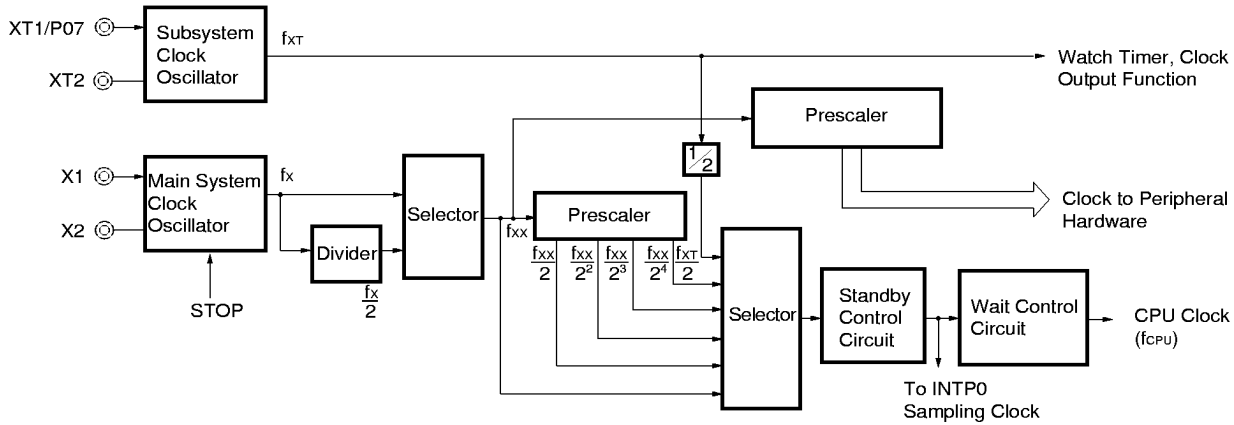

5.3 Timer/Event Counter

5 timer/event counter channels are incorporated.

- 16-bit timer/event counter : 1 channel
- 8-bit timer/event counter : 2 channels
- Watch timer : 1 channel
- Watchdog timer : 1 channel

Table 5-2. Operation of Timer/Event Counter

	16-Bit Timer/Event Counter	8-Bit Timer/Event Counter	Watch Timer	Watchdog Timer
Operation mode				
Interval timer	1 channel	2 channels	1 channel	1 channel
External event counter	1 channel	2 channels	—	—
Function				
Timer output	1 output	2 outputs	—	—
PWM output	1 output	—	—	—
Pulse width measurement	2 input	—	—	—
Square wave output	1 output	2 outputs	—	—
One-shot pulse output	1 output	—	—	—
Interrupt request	2	2	1	1
Test input	—	—	1 input	—

Figure 5-2. 16-Bit Timer/Event Counter Block Diagram

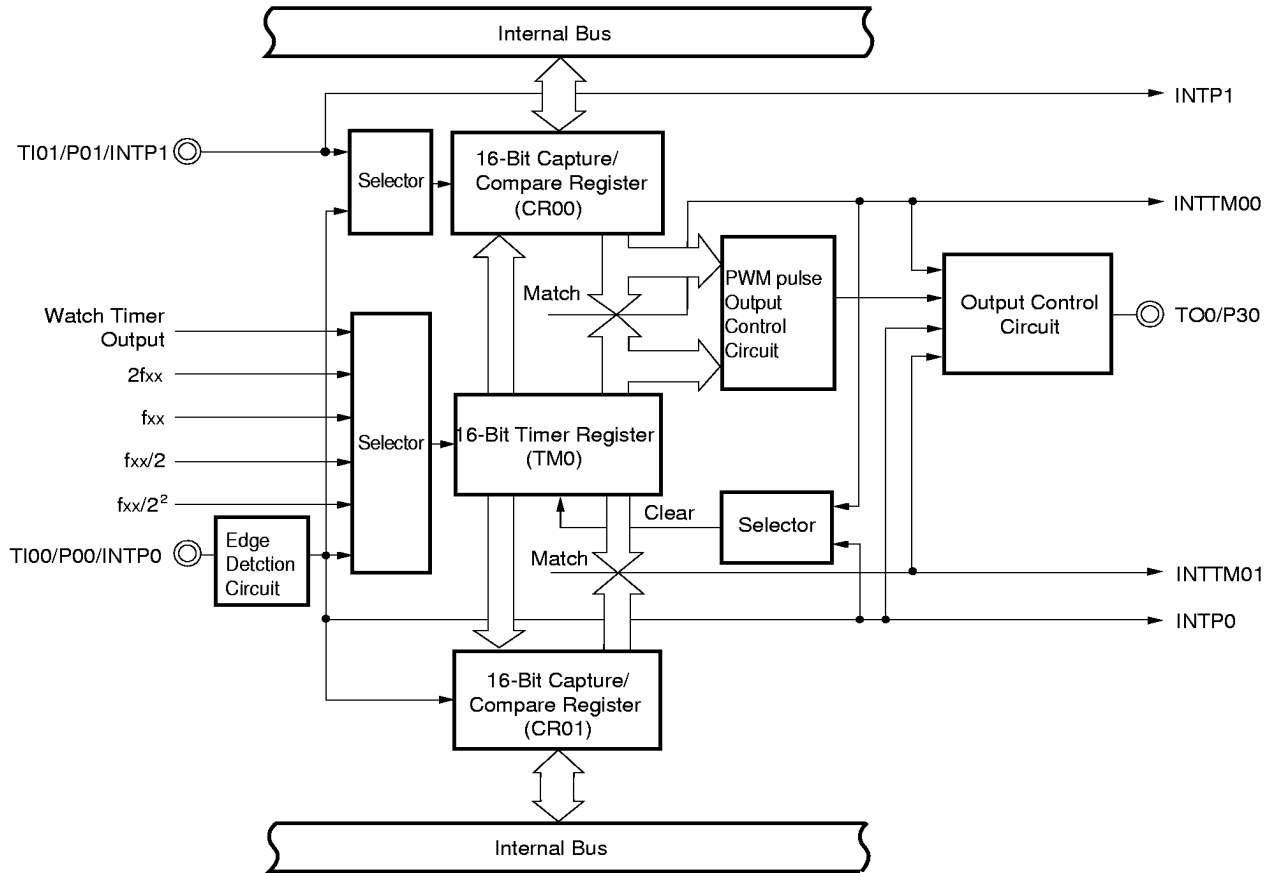

Figure 5-3. 8-Bit Timer/Event Counter Block Diagram

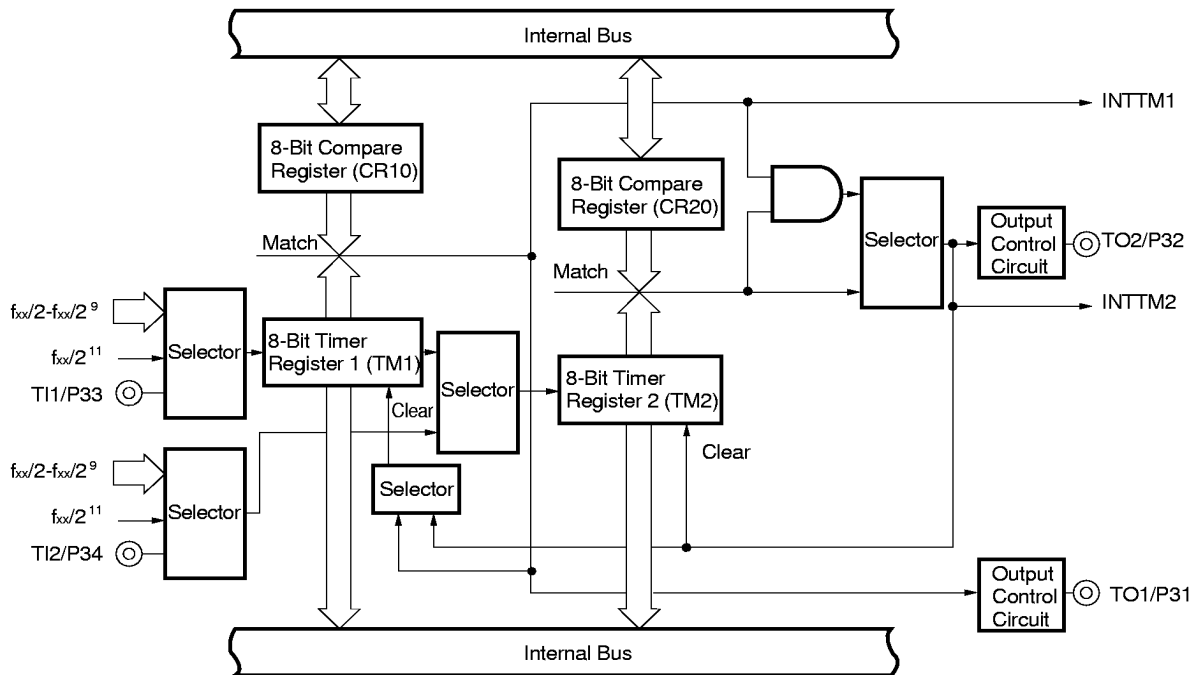

Figure 5-4. Watch Timer Block Diagram

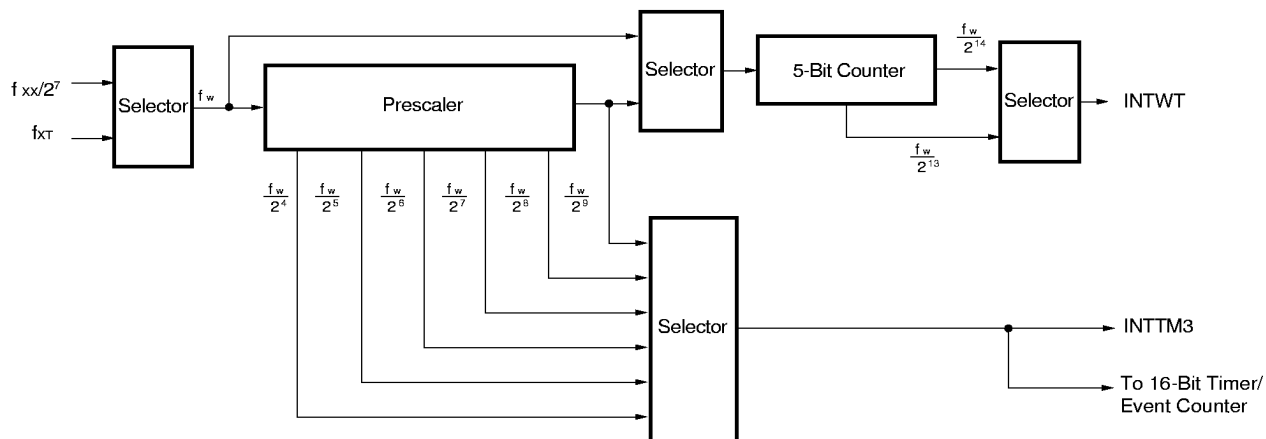
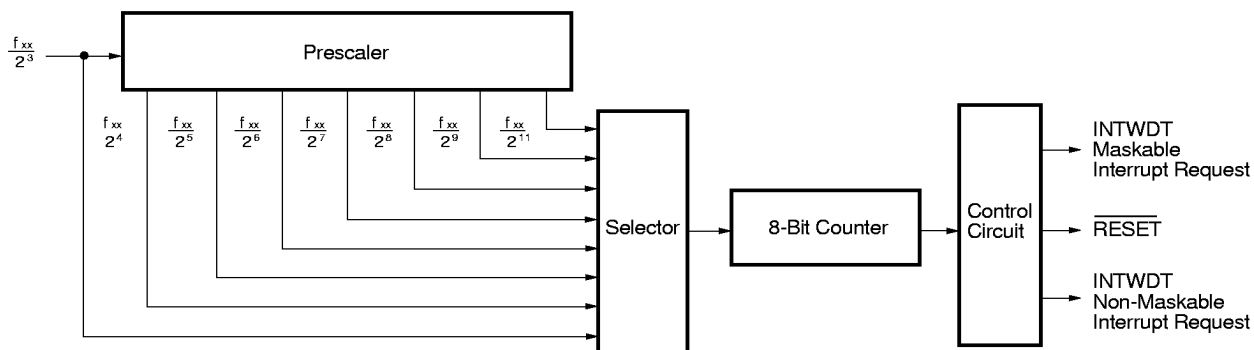

Figure 5-5. Watchdog Timer Block Diagram



5.4 Clock Output Control Circuit

Clock with the following frequencies can be output as clock output.

- 19.5 kHz/39.1 kHz/78.1 kHz/156 kHz/313 kHz/625 kHz/1.25 MHz/2.5 MHz/5.0 MHz (main system clock: at 5.0-MHz operation)
- 32.768 kHz (subsystem clock: at 32.768-kHz operation)

Figure 5-6. Clock Output Control Block Diagram

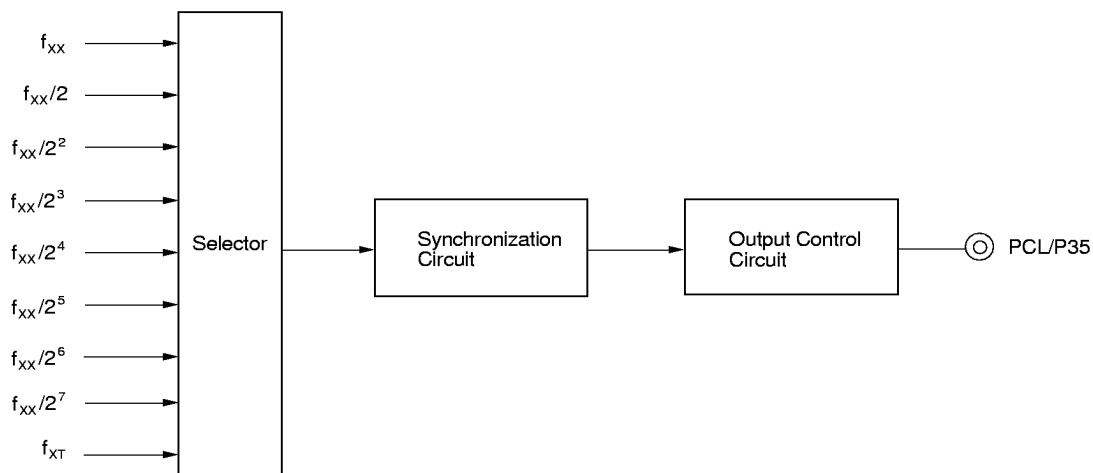

5.5 Buzzer Output Control Circuit

Clock with the following frequencies can be output as buzzer output.

- 1.2 kHz/2.4 kHz/4.9 kHz/9.8 kHz (main system clock: at 5.0-MHz operation)

Figure 5-7. Buzzer Output Control Circuit Block Diagram

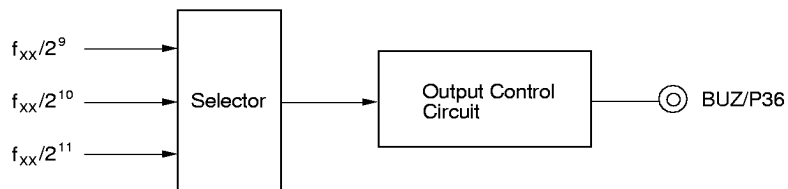

5.6 A/D Converter

An A/D converter of 8-bit resolution × 8 channels is incorporated.

The following two types of A/D conversion operation start-up methods are available.

- Hardware start
- Software start

Figure 5-8. A/D Converter Block Diagram

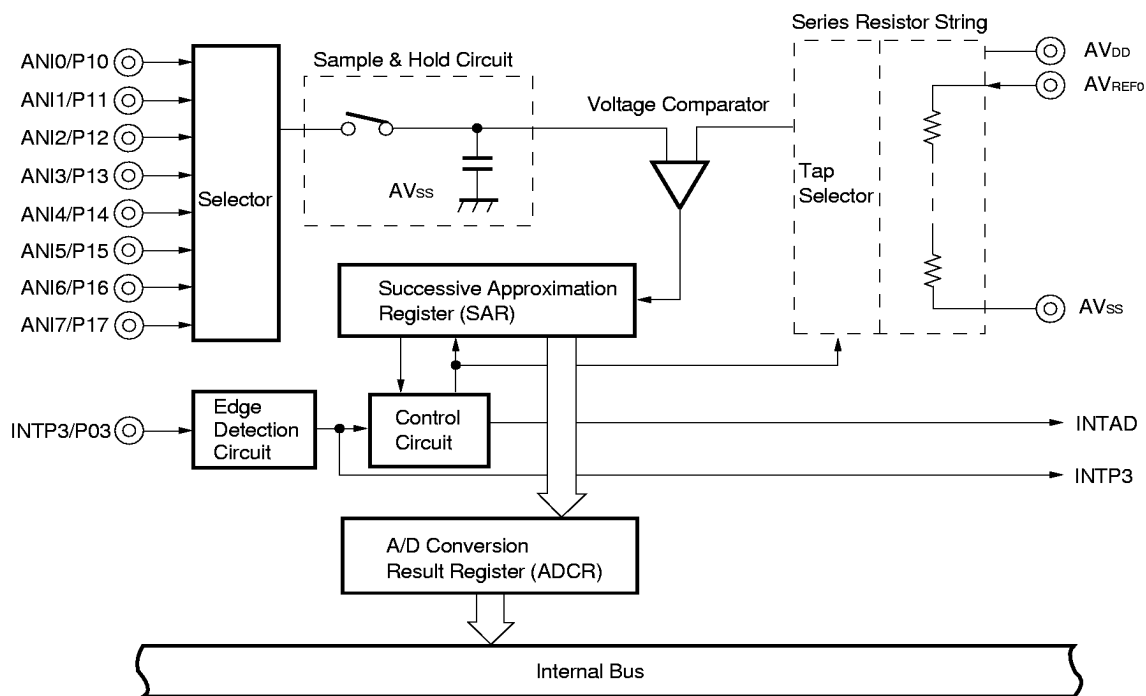

5.7 D/A Converter

A D/A converter of 8-bit resolution × 2 channels is available.
The conversion method is the R-2R resistor ladder method.

Figure 5-9. D/A Converter Block Diagram

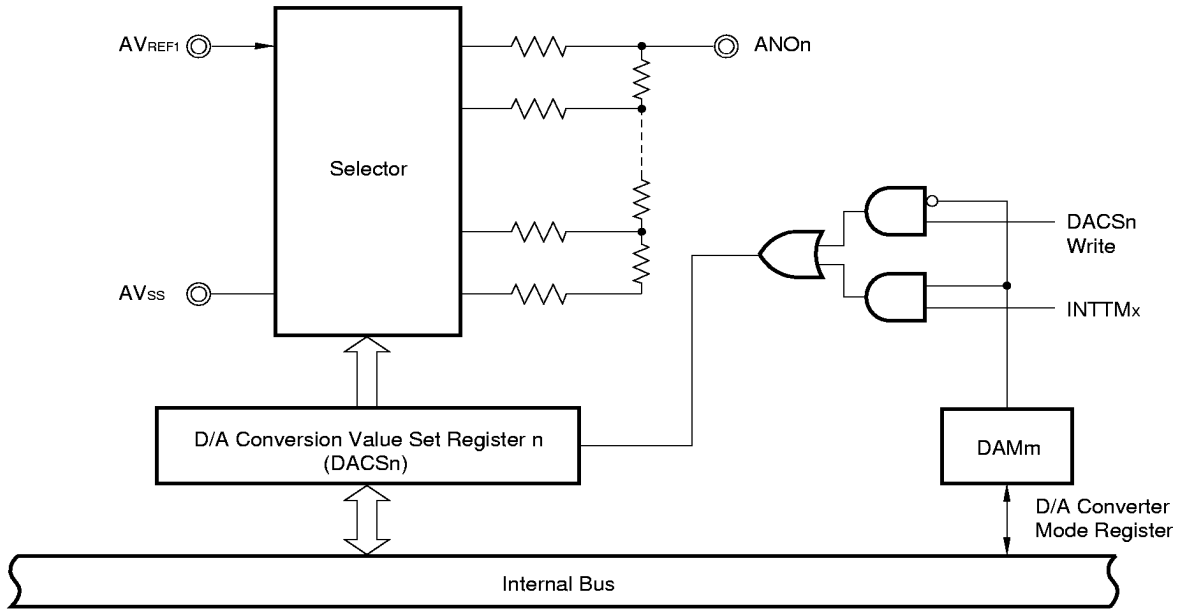

n = 0, 1
m = 4, 5
x = 1, 2

5.8 Serial Interfaces

3 channels of the clocked serial interface are incorporated.

- Serial interface channel 0
- Serial interface channel 1
- Serial interface channel 2

Table 5-3. Types and Functions of Serial Interface

Function	Serial Interface Channel 0	Serial Interface Channel 1	Serial Interface Channel 2
3-wire serial I/O mode	○ (MSB/LSB first switchable)	○ (MSB/LSB first switchable)	○ (MSB/LSB first switchable)
3-wire serial I/O mode with auto-matic transmission/reception function	—	○ (MSB/LSB first switchable)	—
SBI (serial bus interface) mode	○ (MSB first)	—	—
2-wire serial I/O mode	○ (MSB first)	—	—
Asynchronous serial interface (UART) mode	—	—	○ (Dedicated baud rate generator incorporated)

Figure 5-10. Serial Interface Channel 0 Block Diagram

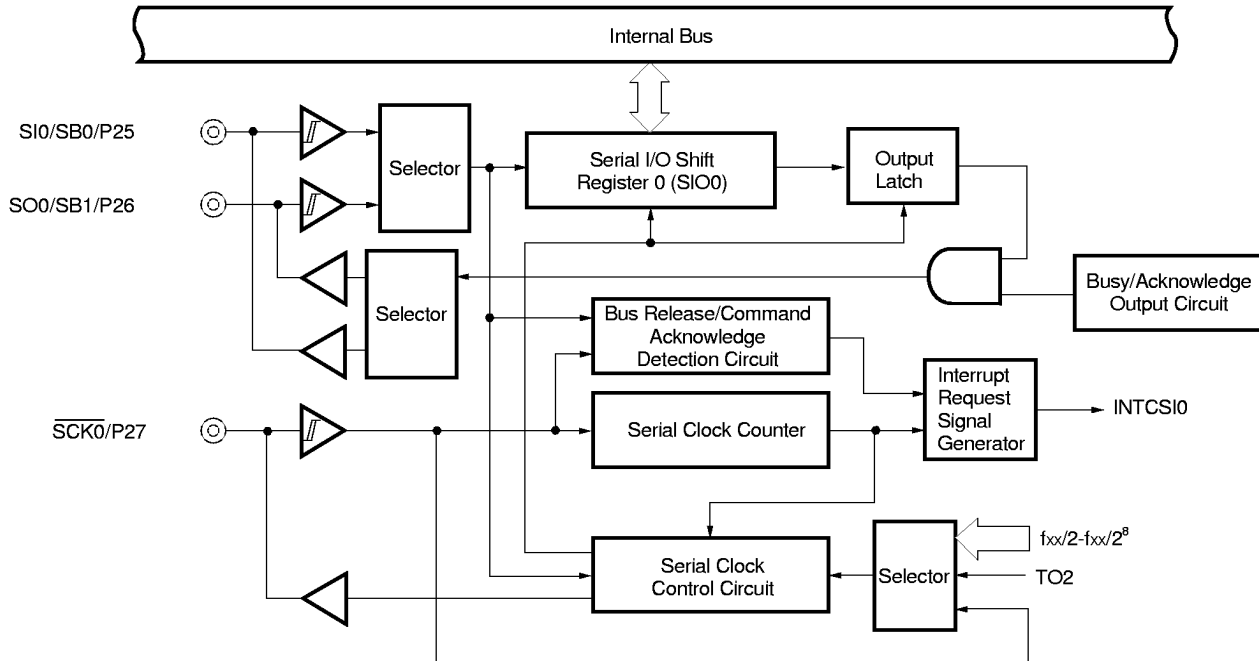

Figure 5-11. Serial Interface Channel 1 Block Diagram

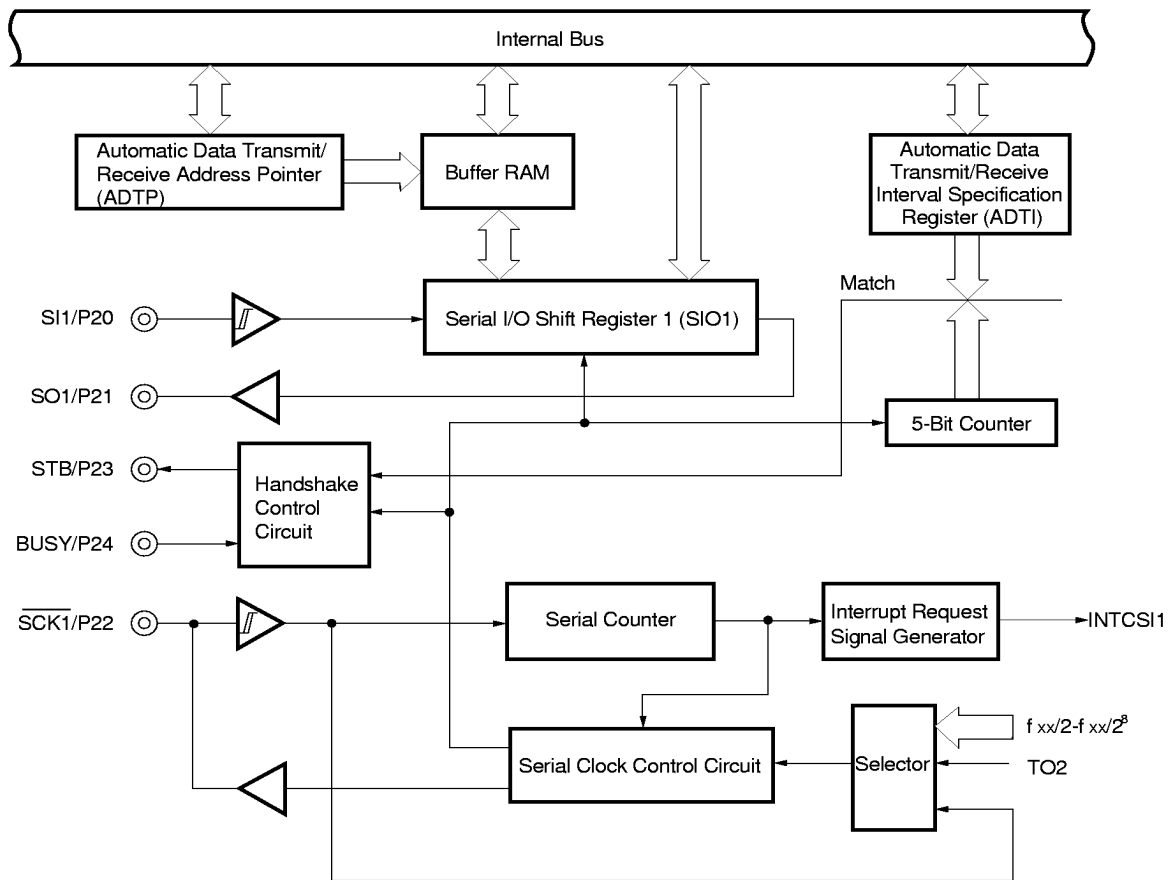
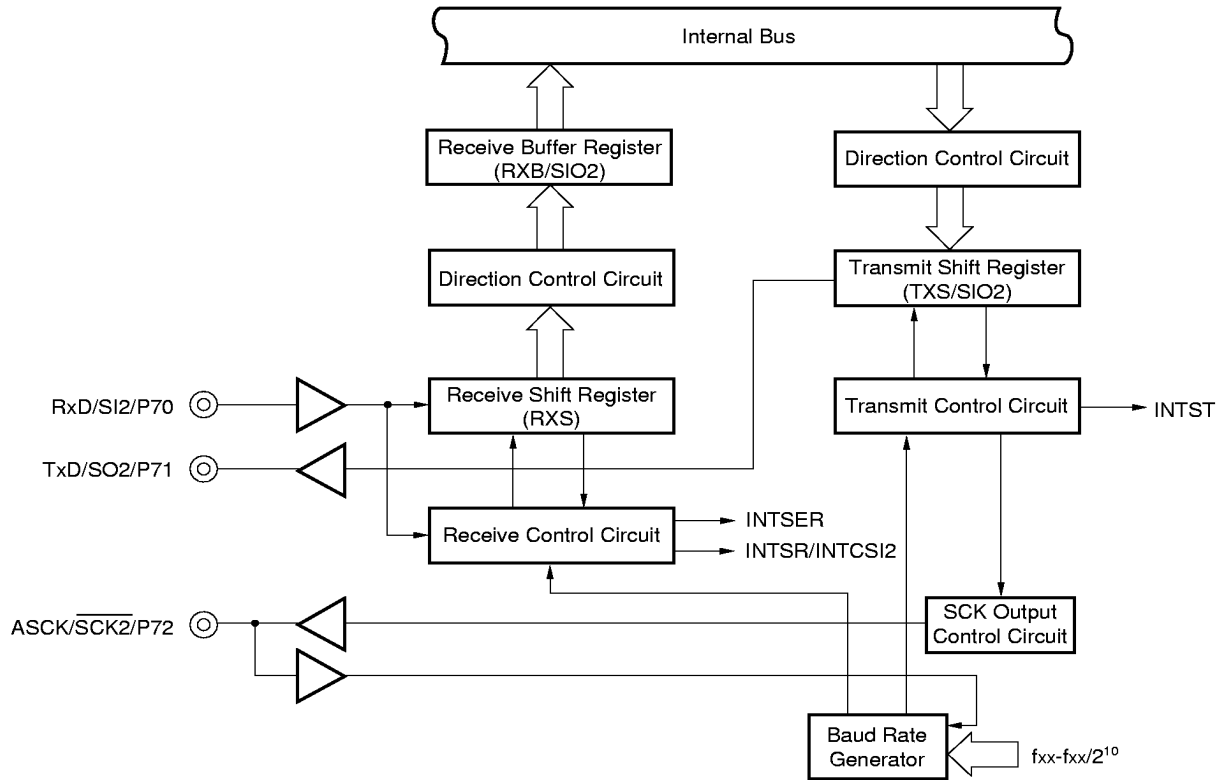

Figure 5-12. Serial Interface Channel 2 Block Diagram



5.9 Real-Time Output Port Functions

Data set previously in the real-time output buffer register is transferred to the output latch by hardware concurrently with timer interrupt request and external interrupt request generation in order to output to off-chip. This is a real-time output function. Pins to output to off-chip are called real-time output ports.

By using a real-time output port, a signal which has no jitter can be output. This is most applicable to control of stepping motors, etc.

Figure 5-13. Real-Time Output Port Block Diagram

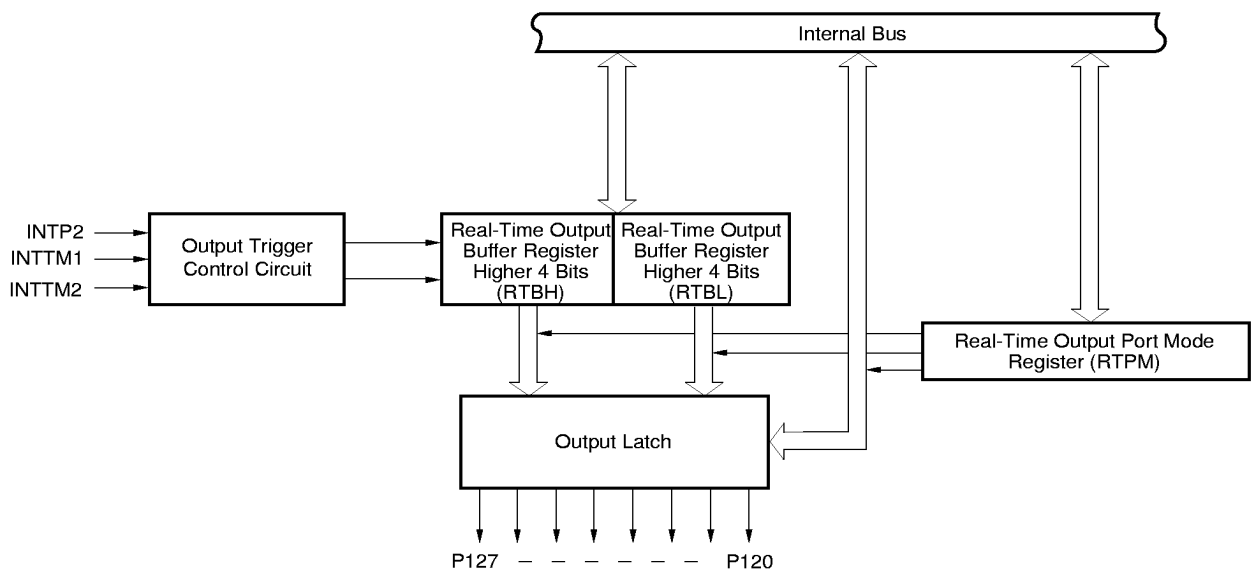

6. INTERRUPT FUNCTIONS AND TEST FUNCTIONS

6.1 Interrupt Functions

There are 22 interrupt functions of 3 different kinds, as shown below.

- Non-maskable : 1
- Maskable : 20
- Software : 1

Table 6-1. Interrupt Source List (1/2)

Interrupt Type	Note 1 Default Priority	Interrupt Source		Internal/ External	Vector Table Address	Basic Configuration Type Note 2		
		Name	Trigger					
Non-maskable	—	INTWDT	Watchdog timer overflow (watchdog timer mode 1 selected)	Internal	0004H	(A)		
Maskable	0	INTWDT	Watchdog timer overflow (interval timer mode selected)			External	0006H	(B)
	1	INTP0	Pin input edge detection	0006H	(C)			
	2	INTP1						
	3	INTP2						
	4	INTP3						
	5	INTP4						
	6	INTP5						
	7	INTP6						
	8	INTCSI0						End of serial interface channel 0 transfer
	9	INTCSI1	End of serial interface channel 1 transfer	0016H				
	10	INTSER	Generation of serial interface channel 2 UART receive error	0018H				
	11	INTSR	End of serial interface channel 2 UART reception	001AH				
		INTCSI2	End of serial interface channel 2 3-wire transfer					
	12	INTST	End of serial interface channel 2 UART transmission	001CH				

Notes 1. The default priority is a priority order when two or more maskable interrupt requests are generated simultaneously. 0 is the highest order and 18, the lowest.

2. Basic configuration types (A) to (E) correspond to (A) to (E) in Figure 6-1, respectively.

Table 6-1. Interrupt Source List (2/2)

Interrupt Type	Note 1 Default Priority	Interrupt Source		Internal/ External	Vector Table Address	Basic Configuration Type Note 2
		Name	Trigger			
Maskable	13	INTTM3	Reference time interval signal from watch timer	Internal	001EH	(B)
	14	INTTM00	Generation of match signal of 16-bit timer register and capture/compare register (CR00)		0020H	
	15	INTTM01	Generation of match signal of 16-bit timer register and capture/compare register (CR01)		0022H	
	16	INTTM1	Generation of match signal of 8-bit timer/event counter 1		0024H	
	17	INTTM2	Generation of match signal of 8-bit timer/event counter 2		0026H	
	18	INTAD	End of conversion by A/D converter		0028H	
Software	—	BRK	BRK instruction execution	—	003EH	(E)

- Notes**
1. The default priority is a priority order when two or more maskable interrupt requests are generated simultaneously. 0 is the highest order and 18, the lowest.
 2. Basic configuration types (A) to (E) correspond to (A) to (E) in Figure 6-1, respectively.

Figure 6-1. Interrupt Function Basic Configuration (1/2)

(A) Internal non-maskable interrupt

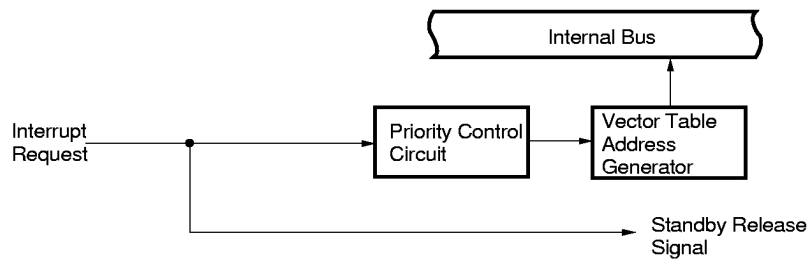

(B) Internal maskable interrupt

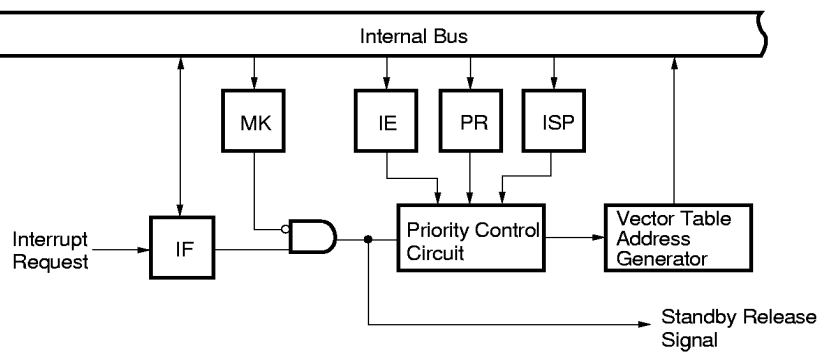

(C) External maskable interrupt (INTP0)

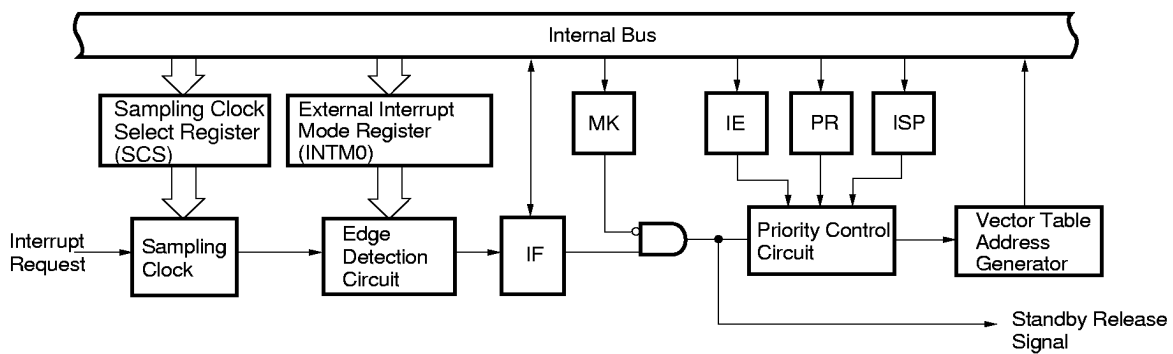
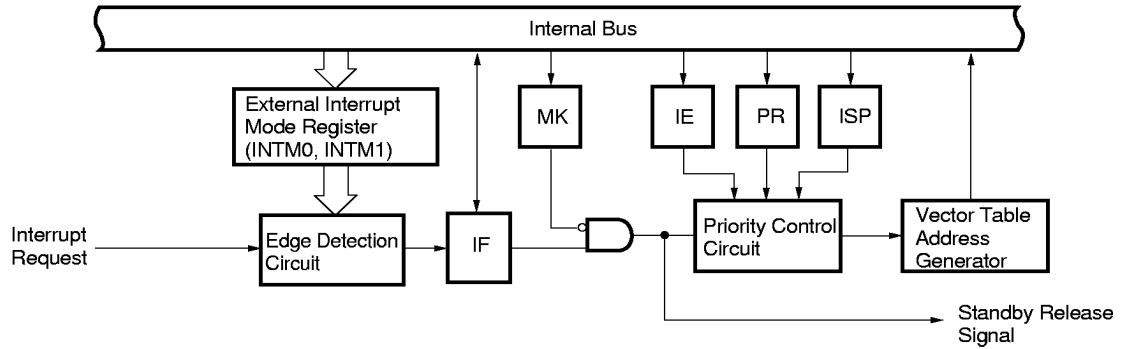
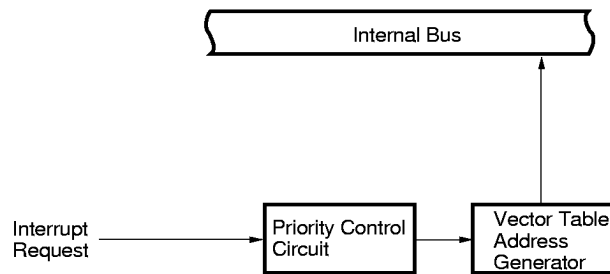

Figure 6-1. Interrupt Function Basic Configuration (2/2)

(D) External maskable interrupt (except INTP0)



(E) Software Interrupt



- IF** : Interrupt request flag
- IE** : Interrupt enable flag
- ISP** : In-service priority flag
- MK** : Interrupt mask flag
- PR** : Priority specification flag

6.2 Test Functions

There are two test functions as shown in Table 6-2.

Table 6-2. Test Input Source List

Test Input Source		Internal/External
Name	Trigger	
INTWT	Watch timer overflow	Internal
INTPT4	Port 4 falling edge detection	External

Figure 6-2. Test Function Basic Configuration

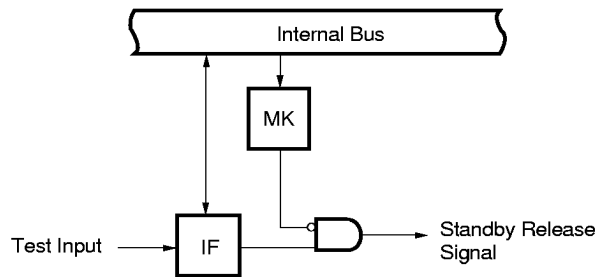

IF : Test input flag
 MK : Test mask flag

7. EXTERNAL DEVICE EXPANSION FUNCTIONS

The external device expansion functions connect external devices to areas other than the internal ROM, RAM and SFR. Ports 4 to 6 are used for external device connection.

8. STANDBY FUNCTION

There are the following two standby functions to reduce the system power consumption.

- HALT mode : The CPU operating clock is stopped.
The average consumption current can be reduced by intermittent operation in combination with the normal operating mode.
- STOP mode : The main system clock oscillation is stopped. The whole operation by the main system clock is stopped, so that the system operates with ultra-low power consumption using only the subsystem clock.

Figure 8-1. Stand-by Function

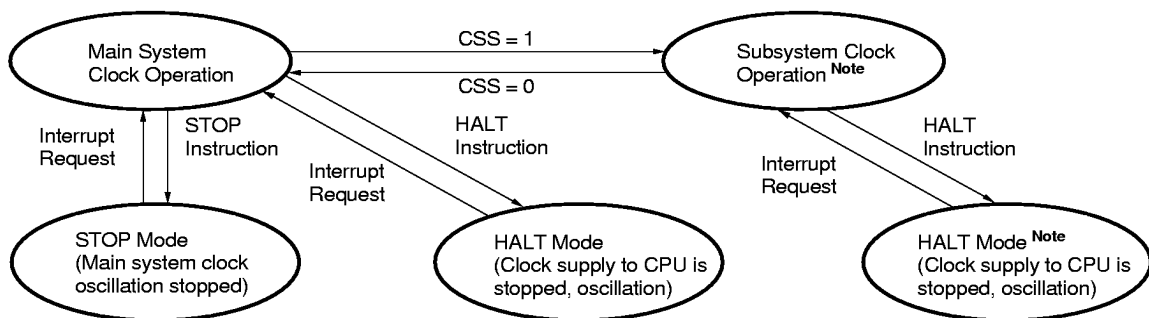

Note The power consumption can be reduced by stopping the main system clock. When the CPU is operating on the subsystem clock, set bit 7 (MCC) in the processor clock control register (PCC) to stop the main system clock. The STOP instruction cannot be used.

Caution When the main system clock is stopped and the system is operated by the subsystem clock, the subsystem clock should be switched again to the main system clock after the oscillation stabilization time is secured by the program.

Remark CSS : bit 4 in the PCC

9. RESET FUNCTION

There are the following two reset methods.

- External reset input by $\overline{\text{RESET}}$ pin
- Internal reset by watchdog time runaway time detection

10. INSTRUCTION SET

(1) 8-bit instructions

MOV, XCH, ADD, ADDC, SUB, SUBC, AND, OR, XOR, CMP, MULU, DIVUW, INC, DEC, ROR, ROL, RORC, ROLC, ROR4, ROL4, PUSH, POP, DBNZ

Second Operand First Operand	#byte	A	r Note	sfr	saddr	laddr16	PSW	[DE]	[HL]	[HL + Byte] [HL + B] [HL + C]	\$addr16	1	None
A	ADD ADDC SUB SUBC AND OR XOR CMP		MOV XCH ADD ADDC SUB SUBC AND OR XOR CMP	MOV XCH	MOV XCH ADD ADDC SUB SUBC AND OR XOR CMP	MOV XCH ADD ADDC SUB SUBC AND OR XOR CMP	MOV	MOV XCH	MOV XCH ADD ADDC SUB SUBC AND OR XOR CMP	MOV XCH ADD ADDC SUB SUBC AND OR XOR CMP		ROR ROL RORC ROLC	
r	MOV	MOV ADD ADDC SUB SUBC AND OR XOR CMP											INC DEC
B, C											DBNZ		
sfr	MOV	MOV											
saddr	MOV ADD ADDC SUB SUBC AND OR XOR CMP	MOV									DBNZ		INC DEC
laddr16		MOV											
PSW	MOV	MOV											PUSH POP
[DE]		MOV											
[HL]		MOV											ROR4 ROL4
[HL + Byte] [HL + B] [HL + C]		MOV											
X													MULU
C													DIVUW

Note Except r = A

(2) 16-bit Instructions

MOVW, XCHW, ADDW, SUBW, CMPW, PUSH, POP, INCW, DECW

Second Operand First Operand	#word	AX	rp ^{Note}	sfrp	saddrp	!addr16	SP	None
AX	ADDW SUBW CMPW		MOVW XCHW	MOVW	MOVW	MOVW	MOVW	
rp	MOVW	MOVW ^{Note}						INCW, DECW PUSH, POP
sfrp	MOVW	MOVW						
saddrp	MOVW	MOVW						
!addr16		MOVW						
SP	MOVW	MOVW						

Note Only when rp = BC, DE or HL

(3) Bit manipulation instructions

MOV1, AND1, OR1, XOR1, SET1, CLR1, NOT1, BT, BF, BTCLR

Second Operand First Operand	A.bit	sfr.bit	saddr.bit	PSW.bit	[HL].bit	CY	\$addr16	None
A.bit						MOV1	BT BF BTCLR	SET1 CLR1
sfr.bit						MOV1	BT BF BTCLR	SET1 CLR1
saddr.bit						MOV1	BT BF BTCLR	SET1 CLR1
PSW.bit						MOV1	BT BF BTCLR	SET1 CLR1
[HL].bit						MOV1	BT BF BTCLR	SET1 CLR1
CY	MOV1 AND1 OR1 XOR1	MOV1 AND1 OR1 XOR1	MOV1 AND1 OR1 XOR1	MOV1 AND1 OR1 XOR1	MOV1 AND1 OR1 XOR1			SET1 CLR1 NOT1

(4) Call instruction/branch instructions

CALL, CALLF, CALLT, BR, BC, BNC, BZ, BNZ, BT, BF, BTCLR, DBNZ

Second Operand First Operand	AX	!addr16	!addr11	[addr5]	\$addr16
Basic instruction	BR	CALL BR	CALLF	CALLT	BR, BC, BNC BZ, BNZ
Compound instruction					BT, BF BTCLR DBNZ

(5) Other Instructions

ADJBA, ADJBS, BRK, RET, RETI, RETB, SEL, NOP, EI, DI, HALT, STOP

11. ELECTRICAL SPECIFICATIONS

Absolute Maximum Ratings (T_A = 25°C)

Parameter	Symbol	Test Conditions		Rating	Unit	
Supply voltage	V _{DD}			-0.3 to + 7.0	V	
	AV _{DD}			-0.3 to V _{DD} + 0.3	V	
	AV _{REF0}			-0.3 to V _{DD} + 0.3	V	
	AV _{REF1}			-0.3 to V _{DD} + 0.3	V	
	AV _{SS}			-0.3 to + 0.3	V	
Input voltage	V _{I1}	P00 to P07, P10 to P17, P20 to P27, P30 to P37, P40 to P47, P50 to P57, P64 to P67, P70 to P72, P120 to P127, P130, P131, X1, X2, XT2 $\overline{\text{RESET}}$		-0.3 to V _{DD} + 0.3	V	
	V _{I2}	P60 to P63	N-ch Open-drain	-0.3 to +16	V	
Output voltage	V _O			-0.3 to V _{DD} + 0.3	V	
Analog input voltage	V _{AN}	P10 to P17	Analog input pin	AV _{SS} -0.3 to AV _{REF0} + 0.3	V	
High level output current	I _{OH}	1 pin		-10	mA	
		P01 to P06, P30-P37, P56, P57, P60 to P67, P120 to P127 total		-15	mA	
		P10 to P17, P20 to P27, P40 to P47, P50 to P55, P70 to P72, P130, P131 total		-15	mA	
Low level output current	I _{OL} <small>Note</small>	1 pin		Peak value	30	mA
				Effective value	15	mA
		P50 to P55 total		Peak value	100	mA
				Effective value	70	mA
		P56, P57, P60 to P63 total		Peak value	100	mA
				Effective value	70	mA
		P10 to P17, P20 to P27, P40 to P47, P70 to P72, P130, P131 total		Peak value	50	mA
				Effective value	20	mA
		P01 to P06, P30 to P37, P64 to P67, P120 to P127 total		Peak value	50	mA
				Effective value	20	mA
Operating ambient temperature	T _A			-40 to +85	°C	
Storage temperature	T _{stg}			-65 to +150	°C	

Note The effective value should be calculated as follows: [Effective value] = [Peak value] × $\sqrt{\text{duty}}$

Caution Product quality may suffer if the absolute maximum rating is exceeded even momentarily for any parameter. That is, the absolute maximum ratings are rated values at which the product is on the verge of suffering physical damage, and therefore the product must be used under conditions that ensure that the absolute maximum ratings are not exceeded.

Remark Unless specified otherwise, alternate-function pin characteristics are the same as port pin characteristics.

Main System Clock Oscillation Circuit Characteristics (T_A = -40 to 85°C, V_{DD} = 2.7 to 6.0 V)

Resonator	Recommended Circuit	Parameter	Test Conditions	MIN.	TYP.	MAX.	Unit
Ceramic resonator		Oscillator frequency (f _x) Note 1	V _{DD} = Oscillator voltage range	1.0		5.0	MHz
		Oscillation stabilization time Note 2	After V _{DD} reaches oscillator voltage range MIN.			4	ms
Crystal resonator		Oscillator frequency (f _x) Note 1		1.0		5.0	MHz
		Oscillation stabilization time Note 2	V _{DD} = 4.5 to 6.0 V			10 30	ms
External clock		X1 input frequency (f _x) Note 1		1.0		5.0	MHz
		X1 input high/low level width (t _{xH} , t _{xL})		85		500	ns

Notes 1. Indicates only oscillation circuit characteristics. Refer to "AC Characteristics" for instruction execution time.

2. Time required to stabilize oscillation after reset or STOP mode release.

Cautions 1. When using the main system clock oscillator, wiring in the area enclosed with the broken line in the above figures should be carried out as follows to avoid an adverse effect from wiring capacitance.

- Wiring should be as short as possible.
- Wiring should not cross other signal lines.
- Wiring should not be placed close to a varying high current.
- The potential of the oscillator capacitor ground should be the same as V_{SS}.
- Do not ground wiring to a ground pattern in which a high current flows.
- Do not fetch a signal from the oscillator.

2. When the main system clock is stopped and the system is operated by the subsystem clock, the subsystem clock should be switched again to the main system clock after the oscillation stabilization time is secured by the program.

Subsystem Clock Oscillation Circuit Characteristics ($T_A = -40$ to $+85^\circ\text{C}$, $V_{DD} = 2.7$ to 6.0 V)

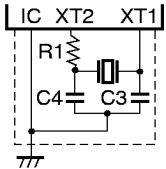
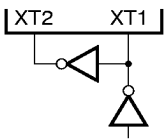
Resonator	Recommended Circuit	Parameter	Test Conditions	MIN.	TYP.	MAX.	Unit
Crystal resonator		Oscillator frequency (f_{XT}) Note 1		32	32.768	35	kHz
		Oscillation stabilization time Note 2	$V_{DD} = 4.5$ to 6.0 V		1.2	2	s
External clock		XT1 input frequency (f_{XT}) Note 1		32		100	
		XT1 input high-/low-level width (t_{xTH} , t_{xTL})			5		15

- Notes**
1. Indicates only oscillation circuit characteristics. Refer to “AC Characteristics” for instruction execution time.
 2. Time required to stabilize oscillation after V_{DD} reaches oscillator voltage MIN.

Cautions

1. When using the subsystem clock oscillator, wiring in the area enclosed with the broken line in the above figures should be carried out as follows to avoid an adverse effect from wiring capacitance.

- Wiring should be as short as possible.
- Wiring should not cross other signal lines.
- Wiring should not be placed close to a varying high current.
- The potential of the oscillator capacitor ground should be the same as V_{SS} .
- Do not ground wiring to a ground pattern in which a high current flows.
- Do not fetch a signal from the oscillator.

2. The subsystem clock oscillator is a low-amplitude circuit in order to achieve a low consumption current, and is more prone to malfunction due to noise than the main system clock oscillator. Particular care is therefore required with the wiring method when the subsystem clock is used.

Capacitance (T_A = 25°C, V_{DD} = V_{SS} = 0 V)

Parameter	Symbol	Test Conditions		MIN.	TYP.	MAX.	Unit
Input capacitance	C _{IN}	f = 1 MHz Measured pins returned to 0 V.				15	pF
I/O capacitance	C _{IO}	f = 1 MHz Measured pins returned to 0 V.	P01 to P06, P10 to P17, P20 to P27, P30 to P37, P40 to P47, P50 to P57, P64 to P67, P70 to P72, P120 to P127, P130, P131			15	pF
			P60 to P63			20	pF

Remark The characteristics of the alternate-function pins are the same as those of the port pins unless otherwise specified.

DC Characteristics (T_A = -40 to +85°C, V_{DD} = 2.7 to 6.0 V)

Parameter	Symbol	Test Conditions	MIN.	TYP.	MAX.	Unit	
Input voltage, high	V _{IH1}	P10 to P17, P21, P23, P30 to P32, P35 to P37, P40 to P47, P50 to P57, P64 to P67, P71, P120 to P127, P130, P131	0.7 V _{DD}		V _{DD}	V	
	V _{IH2}	P00 to P06, P20, P22, P24 to P27, P33, P34, P70, P72, $\overline{\text{RESET}}$	0.8 V _{DD}		V _{DD}	V	
	V _{IH3}	P60 to P63 (N-ch Open-drain)	0.7 V _{DD}		15	V	
	V _{IH4}	X1, X2	V _{DD} -0.5		V _{DD}	V	
	V _{IH5}	XT1/P07, XT2	V _{DD} = 4.5 to 6.0 V	0.8 V _{DD}		V _{DD}	V
			0.9 V _{DD}		V _{DD}	V	
Input voltage, low	V _{IL1}	P10 to P17, P21, P23, P30 to P32, P35 to P37, P40 to P47, P50 to P57, P64 to P67, P71, P120 to P127, P130, P131	0		0.3 V _{DD}	V	
	V _{IL2}	P00 to P06, P20, P22, P24 to P27, P33, P34, P70, P72, $\overline{\text{RESET}}$	0		0.2 V _{DD}	V	
	V _{IL3}	P60 to P63	V _{DD} = 4.5 to 6.0 V	0		0.3 V _{DD}	V
				0		0.2 V _{DD}	V
	V _{IL4}	X1, X2		0		0.4	V
V _{IL5}	XT1/P07, XT2	V _{DD} = 4.5 to 6.0 V	0		0.2 V _{DD}	V	
			0		0.1 V _{DD}	V	
Output voltage, high	V _{OH}	V _{DD} = 4.5 to 6.0 V, I _{OH} = -1mA	V _{DD} -1.0			V	
		I _{OH} = -100 μA	V _{DD} -0.5			V	
Output voltage, low	V _{OL1}	P50 to P57, P60 to P63	V _{DD} = 4.5 to 6.0 V, I _{OL} = 15 mA	0.4	2.0	V	
		P01 to P06, P10 to P17, P20 to P27, P30 to P37, P40 to P47, P64 to P67, P70 to P72, P120 to P127, P130, P131	V _{DD} = 4.5 to 6.0 V, I _{OL} = 1.6 mA		0.4	V	
	V _{OL2}	SB0, SB1, $\overline{\text{SCK0}}$	V _{DD} = 4.5 to 6.0 V, N-ch open-drain at pull-up time(R = 1 kΩ)		0.2 V _{DD}	V	
	V _{OL3}	I _{OL} = 400 μA			0.5	V	
Input leakage current, high	I _{LIH1}	V _{IN} = V _{DD}	P00 to P06, P10 to P17, P20 to P27, P30 to P37, P40 to P47, P50 to P57, P60 to P67, P70 to P72, P120 to P127, P130, P131 $\overline{\text{RESET}}$		3	μA	
			X1, X2, XT1/P07, XT2		20	μA	
	I _{LIH3}	V _{IN} = 15 V	P60 to P63		80	μA	

Remark The characteristics of alternate-function pins and a port pin are the same unless specified otherwise.

DC Characteristics (T_A = -40 to +85°C, V_{DD} = 2.7 to 6.0 V)

Parameter	Symbol	Test Conditions		MIN.	TYP.	MAX.	Unit
Input leakage current, low	I _{LIL1}	V _{IN} = 0 V	P00 to P06, P10 to P17, P20 to P27, P30 to P37, P40 to P47, P50 to P57, P64 to P67, P70 to P72, P120 to P127, P130, P131, $\overline{\text{RESET}}$			-3	μA
	I _{LIL2}		X1, X2, XT1/P07, XT2			-20	μA
	I _{LIL3}		P60 to P63			-3 Note	μA
Output leakage current, high	I _{LOH}	V _{OUT} = V _{DD}				3	μA
Output leakage current, low	I _{LOL}	V _{OUT} = 0 V				-3	μA
Mask option pull-up resistor	R ₁	V _{IN} = 0 V, P60 to P63		20	40	90	kΩ
Software pull-up resistor	R ₂	V _{IN} = 0 V, P01 to P06, P10 to P17, P20 to P27, P30 to P37, P40 to P47, P50 to P57, P64 to P67, P70 to P72, P120 to P127, P130, P131	V _{DD} = 4.5 V to 6.0 V	15	40	90	kΩ
				20		500	kΩ

Note When the pull-up resistor is not included in P60 to P63 (specified by a mask option), a -200 μA (MAX.) low-level input leakage current flows only at the 1.5 clock interval (no wait) when the read instruction to port 6 (PM6) and port mode register (PM6) is executed. At times other than this 1.5 interval, a -3 μA (MAX.) current flows.

Remark The characteristics of alternate-function pins and port pins are the same unless specified otherwise.

DC Characteristics (T_A = -40 to +85°C, V_{DD} = 2.7 to 6.0 V)

Parameter	Symbol	Test Conditions	MIN.	TYP.	MAX.	Unit	
Power supply current Note 1	I _{DD1}	5.0-MHz crystal oscillation operating mode (f _{xx} = 2.5 MHz) Note 2	V _{DD} = 5.0 V ± 10% Note 5		4	12	mA
			V _{DD} = 3.0 V ± 10% Note 6		0.6	1.8	mA
		5.0-MHz crystal oscillation operating mode (f _{xx} = 5.0 MHz) Note 3	V _{DD} = 5.0 V ± 10% Note 5		6.5	19.5	mA
			V _{DD} = 3.0 V ± 10% Note 6		0.8	2.4	mA
	I _{DD2}	5.0-MHz crystal oscillation HALT mode (f _{xx} = 2.5 MHz) Note 2	V _{DD} = 5.0 V ± 10%		1.4	4.2	mA
			V _{DD} = 3.0 V ± 10%		0.5	1.5	mA
		5.0-MHz crystal oscillation HALT mode (f _{xx} = 5.0 MHz) Note 3	V _{DD} = 5.0 V ± 10%		1.6	4.8	mA
			V _{DD} = 3.0 V ± 10%		0.65	1.95	mA
	I _{DD3}	32.768-kHz crystal oscillation operating mode Note 4	V _{DD} = 5.0 V ± 10%		60	120	μA
			V _{DD} = 3.0 V ± 10%		32	64	μA
	I _{DD4}	32.768-kHz crystal oscillation HALT mode Note 4	V _{DD} = 5.0 V ± 10%		25	55	μA
			V _{DD} = 3.0 V ± 10%		5	15	μA
I _{DD5}	XT1 = V _{DD} STOP mode When feedback resistor is used	V _{DD} = 5.0 V ± 10%		1	30	μA	
		V _{DD} = 3.0 V ± 10%		0.5	10	μA	
I _{DD6}	XT1 = V _{DD} STOP mode When feedback resistor is not used	V _{DD} = 5.0 V ± 10%		0.1	30	μA	
		V _{DD} = 3.0 V ± 10%		0.05	10	μA	

Notes 1. Flows through the V_{DD} and AV_{DD} pins. Does not include the current which flows through the A/D converter, D/A converter, and on-chip pull-up resistor.

- 2. f_{xx} = f_x/2 operation (when oscillation mode selection register (OSMS) is set to 00H)
- 3. f_{xx} = f_x operation (when the OSMS is set to 01H)
- 4. When the main system clock is stopped
- 5. High-speed mode operation (when a processor clock control register (PCC) is set to 00H)
- 6. Low-speed mode operation (when the PCC is set to 04H)

Remarks 1. f_{xx}: Main system clock frequency (f_x or f_x/2)
2. f_x: Main system clock oscillator frequency

AC CHARACTERISTICS

(1) Basic Operation (T_A = -40 to +85°C, V_{DD} = 2.7 to 6.0 V)

Parameter	Symbol	Test Conditions		MIN.	TYP.	MAX.	Unit	
Cycle time (Min. instruction execution time)	T _{CY}	Operating on main system clock	f _{xx} = f _x /2 Note 1	0.8		64	μs	
			f _{xx} = f _x Note 2	V _{DD} = 4.5 to 6.0 V	0.4		32	μs
					0.8		32	μs
		Operating on subsystem clock			40	122	125	μs
TI00 input high-/ low-level width	t _{TIH00} , t _{TIL00}	V _{DD} = 4.5 to 6.0 V		2/f _{sam} +0.1 Note 3			μs	
				2/f _{sam} +0.2 Note 3			μs	
TI01 input high-/ low-level width	t _{TIH01} , t _{TIL01}			10			μs	
TI1, TI2 input frequency	f _{TI1}	V _{DD} = 4.5 to 6.0 V		0		4	MHz	
				0		275	kHz	
TI1, TI2 input high-/low-level width	t _{TIH1} , t _{TIL1}	V _{DD} = 4.5 to 6.0 V		100			ns	
				1.8			μs	
Interrupt request input high-/low -level width	t _{INTH} , t _{INTL}	INTP0	V _{DD} = 4.5 to 6.0 V	2/f _{sam} +0.1 Note 3			μs	
				2/f _{sam} +0.2 Note 3			μs	
		INTP1 to INTP6, KR0 to KR7			10			μs
RESET low-level width	t _{RSL}			10			μs	

- Notes**
1. When oscillation mode selection register is set to 00H
 2. When oscillation mode selection register is set to 01H
 3. In combination with bits 0 (SCS0) and 1 (SCS1) of sampling clock select register (SCS), selection of f_{sam} is possible between f_{xx}/2^N, f_{xx}/32, f_{xx}/64 and f_{xx}/128 (when N= 0 to 4).

- Remarks**
1. f_{xx}: Main system clock frequency (f_x or f_x/2)
 2. f_x: Main system clock oscillation frequency

T_{CY} vs V_{DD} (at f_{xx} = f_x/2 main system clock operation)

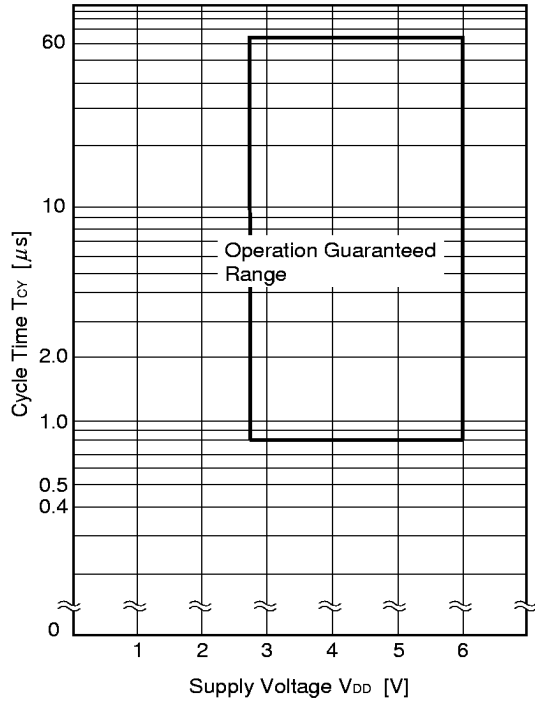

T_{CY} vs V_{DD} (at f_{xx} = f_x main system clock operation)

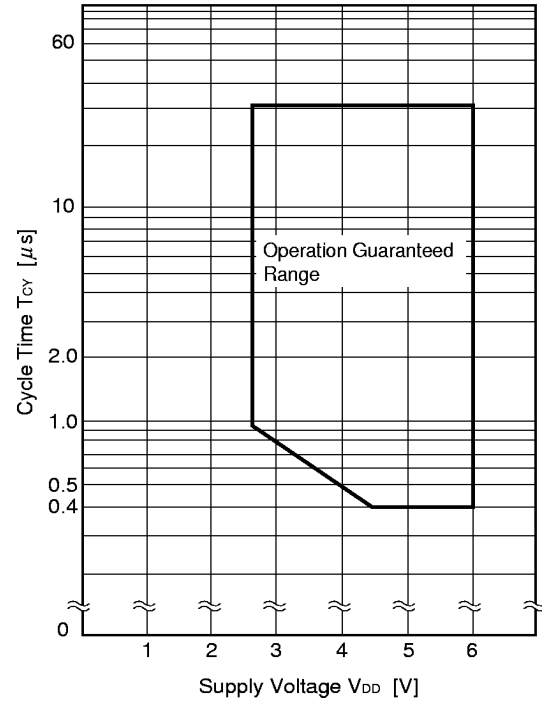

(2) Read/Write Operation

(a) When MCS = 1, PCC2 to PCC0 = 000B (T_A = -40 to + 85°C, V_{DD} = 4.5 to 6.0 V)

Parameter	Symbol	Test Conditions	MIN.	MAX.	Unit
ASTB high-level width	t _{ASTH}		0.85t _{cy} - 50		ns
Address setup time	t _{ADS}		0.85t _{cy} - 50		ns
Address hold time	t _{ADH}		50		ns
Data input time from address	t _{ADD1}			(2.85+2n)t _{cy} -80	ns
	t _{ADD2}			(4+2n)t _{cy} -100	ns
Data input time from $\overline{RD}\downarrow$	t _{RDD1}			(2+2n)t _{cy} -100	ns
	t _{RDD2}			(2.85+2n)t _{cy} -100	ns
Read data hold time	t _{RDH}		0		ns
\overline{RD} low-level width	t _{RDL1}		(2+2n)t _{cy} -60		ns
	t _{RDL2}		(2.85+2n)t _{cy} -60		ns
$\overline{WAIT}\downarrow$ input time from $\overline{RD}\downarrow$	t _{RDWT1}			0.85t _{cy} -50	ns
	t _{RDWT2}			2t _{cy} -60	ns
$\overline{WAIT}\downarrow$ input time from $\overline{WR}\downarrow$	t _{WRWT}			2t _{cy} -60	ns
\overline{WAIT} low-level width	t _{WTL}		(1.15+2n)t _{cy}	(2+2n)t _{cy}	ns
Write data setup time	t _{WDS}		(2.85+2n)t _{cy} -100		ns
Write data hold time	t _{WDH}		20		ns
\overline{WR} low-level width	t _{WRL}		(2.85+2n)t _{cy} -60		ns
$\overline{RD}\downarrow$ delay time from ASTB \downarrow	t _{ASTRD}		25		ns
$\overline{WR}\downarrow$ delay time from ASTB \downarrow	t _{ASTWR}		0.85t _{cy} + 20		ns
ASTB \uparrow delay time from $\overline{RD}\uparrow$ in external fetch	t _{RDAST}		0.85t _{cy} - 10	1.15t _{cy} + 20	ns
Address hold time from $\overline{RD}\uparrow$ in external fetch	t _{RDADH}		0.85t _{cy} - 50	1.15t _{cy} + 50	ns
Write data output time from $\overline{RD}\uparrow$	t _{RDWD}		40		ns
Write data output time from $\overline{WR}\downarrow$	t _{RDWD}		0	50	ns
Address hold time from $\overline{WR}\uparrow$	t _{WRADH}		0.85t _{cy}	1.15t _{cy} + 40	ns
$\overline{RD}\uparrow$ delay time from $\overline{WAIT}\uparrow$	t _{WTRD}		1.15t _{cy} + 40	3.15t _{cy} + 40	ns
$\overline{WR}\uparrow$ delay time from $\overline{WAIT}\uparrow$	t _{WTWR}		1.15t _{cy} + 30	3.15t _{cy} + 30	ns

- Remarks**
1. MCS: Oscillation mode selection register (OSMS) bit 0
 2. PCC2 to PCC0: Processor clock control register (PCC) bit 2 to bit 0
 3. t_{cy} = T_{cy}/4
 4. n indicates the number of waits.

(b) Except when MCS = 1, PCC2 to PCC0 = 000B (T_A = -40 to + 85°C, V_{DD} = 2.7 to 6.0 V)

Parameter	Symbol	Test Conditions	MIN.	MAX.	Unit
ASTB high-level width	t _{ASTH}		t _{cy} - 80		ns
Address setup time	t _{ADS}		t _{cy} - 80		ns
Address hold time	t _{ADH}		0.4t _{cy} - 10		ns
Data input time from address	t _{ADD1}			(3+2n)t _{cy} -160	ns
	t _{ADD2}			(4+2n)t _{cy} -200	ns
Data input time from $\overline{RD}\downarrow$	t _{RDD1}			(1.4+2n)t _{cy} -70	ns
	t _{RDD2}			(2.4+2n)t _{cy} -70	ns
Read data hold time	t _{RDH}		0		ns
\overline{RD} low-level width	t _{RDL1}		(1.4+2n)t _{cy} -20		ns
	t _{RDL2}		(2.4+2n)t _{cy} -20		ns
$\overline{WAIT}\downarrow$ input time from $\overline{RD}\downarrow$	t _{RDWT1}			t _{cy} -100	ns
	t _{RDWT2}			2t _{cy} -100	ns
$\overline{WAIT}\downarrow$ input time from $\overline{WR}\downarrow$	t _{WRWT}			2t _{cy} -100	ns
\overline{WAIT} low-level width	t _{WTL}		(1+2n)t _{cy}	(2+2n)t _{cy}	ns
Write data setup time	t _{WDS}		(2.4+2n)t _{cy} -60		ns
Write data hold time	t _{WDH}		20		ns
\overline{WR} low-level width	t _{WRL}		(2.4+2n)t _{cy} -20		ns
$\overline{RD}\downarrow$ delay time from $\overline{ASTB}\downarrow$	t _{ASTRD}		0.4t _{cy} -30		ns
$\overline{WR}\downarrow$ delay time from $\overline{ASTB}\downarrow$	t _{ASTWR}		1.4t _{cy} -30		ns
ASTB \uparrow delay time from $\overline{RD}\uparrow$ in external fetch	t _{RDAST}		t _{cy} -10	t _{cy} + 20	ns
Address hold time from $\overline{RD}\uparrow$ in external fetch	t _{RDADH}		t _{cy} - 50	t _{cy} + 50	ns
Write data output time from $\overline{RD}\uparrow$	t _{RDWD}		0.4t _{cy} - 20		ns
Write data output time from $\overline{WR}\downarrow$	t _{WRWD}		0	60	ns
Address hold time from $\overline{WR}\uparrow$	t _{WRADH}		t _{cy}	t _{cy} + 60	ns
$\overline{RD}\uparrow$ delay time from $\overline{WAIT}\uparrow$	t _{WTRD}		0.6t _{cy} + 180	2.6t _{cy} + 180	ns
$\overline{WR}\uparrow$ delay time from $\overline{WAIT}\uparrow$	t _{WTWR}		0.6t _{cy} + 120	2.6t _{cy} + 120	ns

- Remarks**
1. MCS: Oscillation mode selection register (OSMS) bit 0
 2. PCC2 to PCC0: Processor clock control register (PCC) bit 2 to bit 0
 3. t_{cy} = T_{cy}/4
 4. n indicates the number of waits.

(3) Serial Interface (T_A = -40 to +85°C, V_{DD} = 2.7 to 6.0 V)

(a) Serial interface channel 0

(i) 3-wire serial I/O mode ($\overline{\text{SCK0}}$... Internal clock output)

Parameter	Symbol	Test Conditions	MIN.	TYP.	MAX.	Unit
$\overline{\text{SCK0}}$ cycle time	t _{KCY1}	V _{DD} = 4.5 to 6.0 V	800			ns
			1600			ns
$\overline{\text{SCK0}}$ high-/low-level width	t _{KH1} , t _{KL1}	V _{DD} = 4.5 to 6.0 V	t _{KCY1} /2-50			ns
			t _{KCY1} /2-100			ns
SIO setup time (to $\overline{\text{SCK0}}$ ↑)	t _{SIK1}	V _{DD} = 4.5 to 6.0 V	100			ns
			150			ns
SIO hold time (from $\overline{\text{SCK0}}$ ↑)	t _{KS11}		400			ns
SO0 output delay time from $\overline{\text{SCK0}}$ ↓	t _{KSO1}	C = 100 pF Note			300	ns

Note C is the load capacitance of the $\overline{\text{SCK0}}$ and SO0 output lines.

(ii) 3-wire serial I/O mode ($\overline{\text{SCK0}}$... External clock input)

Parameter	Symbol	Test Conditions	MIN.	TYP.	MAX.	Unit
$\overline{\text{SCK0}}$ cycle time	t _{KCY2}	V _{DD} = 4.5 to 6.0 V	800			ns
			1600			ns
$\overline{\text{SCK0}}$ high-/low-level width	t _{KH2} , t _{KL2}	V _{DD} = 4.5 to 6.0 V	400			ns
			800			ns
SIO setup time (to $\overline{\text{SCK0}}$ ↑)	t _{SIK2}		100			ns
SIO hold time (from $\overline{\text{SCK0}}$ ↑)	t _{KS12}		400			ns
SO0 output delay time from $\overline{\text{SCK0}}$ ↓	t _{KSO2}	C = 100 pF Note			300	ns
$\overline{\text{SCK0}}$ rise, fall time	t _{R2} , t _{F2}	When using external device expansion function			160	ns
		When not using external device expansion function			1000	ns

Note C is the load capacitance of the SO0 output line.

(iii) SBI mode ($\overline{\text{SCK0}}$... Internal clock output)

Parameter	Symbol	Test Conditions		MIN.	TYP.	MAX.	Unit
$\overline{\text{SCK0}}$ cycle time	t_{KCY3}	$V_{\text{DD}} = 4.5 \text{ to } 6.0 \text{ V}$		800			ns
				3200			ns
$\overline{\text{SCK0}}$ high-/low-level width	t_{KH3}	$V_{\text{DD}} = 4.5 \text{ to } 6.0 \text{ V}$		$t_{\text{KCY3}}/2-50$			ns
	t_{KL3}			$t_{\text{KCY3}}/2-150$			ns
SB0, SB1 setup time (to $\overline{\text{SCK0}}\uparrow$)	t_{SIK3}	$V_{\text{DD}} = 4.5 \text{ to } 6.0 \text{ V}$		100			ns
				300			ns
SB0, SB1 hold time (from $\overline{\text{SCK0}}\uparrow$)	t_{KSI3}			$t_{\text{KCY3}}/2$			ns
SB0, SB1 output delay time from $\overline{\text{SCK0}}\downarrow$	t_{KSO3}	$R = 1 \text{ k}\Omega$, $C = 100 \text{ pF}$ Note	$V_{\text{DD}} = 4.5 \text{ to } 6.0 \text{ V}$	0		250	ns
				0		1000	ns
SB0, SB1 \downarrow from $\overline{\text{SCK0}}\uparrow$	t_{KSB}			t_{KCY3}			ns
$\overline{\text{SCK0}}\downarrow$ from SB0, SB1 \downarrow	t_{SBK}			t_{KCY3}			ns
SB0, SB1 high-level width	t_{SBH}			t_{KCY3}			ns
SB0, SB1 low-level width	t_{SBL}			t_{KCY3}			ns

Note R and C are the load resistance and load capacitance of the $\overline{\text{SCK0}}$, SB0, and SB1 output lines.

(iv) SBI mode ($\overline{\text{SCK0}}$... External clock input)

Parameter	Symbol	Test Conditions		MIN.	TYP.	MAX.	Unit
$\overline{\text{SCK0}}$ cycle time	t_{KCY4}	$V_{\text{DD}} = 4.5 \text{ to } 6.0 \text{ V}$		800			ns
				3200			ns
$\overline{\text{SCK0}}$ high-/low-level width	t_{KH4}	$V_{\text{DD}} = 4.5 \text{ to } 6.0 \text{ V}$		400			ns
	t_{KL4}			1600			ns
SB0, SB1 setup time (to $\overline{\text{SCK0}}\uparrow$)	t_{SIK4}	$V_{\text{DD}} = 4.5 \text{ to } 6.0 \text{ V}$		100			ns
				300			ns
SB0, SB1 hold time (from $\overline{\text{SCK0}}\uparrow$)	t_{KSI4}			$t_{\text{KCY4}}/2$			ns
SB0, SB1 output delay time from $\overline{\text{SCK0}}\downarrow$	t_{KSO4}	$R = 1 \text{ k}\Omega$,	$V_{\text{DD}} = 4.5 \text{ to } 6.0 \text{ V}$	0		300	ns
		$C = 100 \text{ pF}$ <small>Note</small>		0		1000	ns
SB0, SB1 \downarrow from $\overline{\text{SCK0}}\uparrow$	t_{KSB}			t_{KCY4}			ns
$\overline{\text{SCK0}}\downarrow$ from SB0, SB1 \downarrow	t_{SBK}			t_{KCY4}			ns
SB0, SB1 high-level width	t_{SBH}			t_{KCY4}			ns
SB0, SB1 low-level width	t_{SBL}			t_{KCY4}			ns
$\overline{\text{SCK0}}$ rise, fall time	$t_{\text{R4}}, t_{\text{F4}}$	When using external device expansion function				160	ns
		When not using external device expansion function				1000	ns

Note R and C are the load resistance and load capacitance of the SB0 and SB1 output lines.

(v) 2-wire serial I/O mode ($\overline{\text{SCK0}}$... Internal clock output)

Parameter	Symbol	Test Conditions		MIN.	TYP.	MAX.	Unit
$\overline{\text{SCK0}}$ cycle time	t_{KCY5}	R = 1 kΩ, C = 100 pF Note		1600			ns
$\overline{\text{SCK0}}$ high-level width	t_{KH5}			$t_{\text{KCY5}}/2-160$			ns
$\overline{\text{SCK0}}$ low-level width	t_{KL5}		$V_{\text{DD}} = 4.5 \text{ to } 6.0 \text{ V}$	$t_{\text{KCY5}}/2-50$			ns
				$t_{\text{KCY5}}/2-100$			ns
SB0, SB1 setup time (to $\overline{\text{SCK0}}\uparrow$)	t_{SIK5}		$V_{\text{DD}} = 4.5 \text{ to } 6.0 \text{ V}$		300		ns
					350		ns
SB0, SB1 hold time (from $\overline{\text{SCK0}}\uparrow$)	t_{KSI5}				600		ns
SB0, SB1 output delay time from $\overline{\text{SCK0}}\downarrow$	t_{KSO5}			0		300	ns

Note R and C are the load resistance and load capacitance of the $\overline{\text{SCK0}}$, SB0, and SB1 output lines.

(vi) 2-wire serial I/O mode ($\overline{\text{SCK0}}$... External clock input)

Parameter	Symbol	Test Conditions		MIN.	TYP.	MAX.	Unit
$\overline{\text{SCK0}}$ cycle time	t_{KCY6}			1600			ns
$\overline{\text{SCK0}}$ high-level width	t_{KH6}			650			ns
$\overline{\text{SCK0}}$ low-level width	t_{KL6}			800			ns
SB0, SB1 setup time (to $\overline{\text{SCK0}}\uparrow$)	t_{SIK6}			100			ns
SB0, SB1 hold time (from $\overline{\text{SCK0}}\uparrow$)	t_{KSI6}			$t_{\text{KCY6}}/2$			ns
SB0, SB1 output delay time from $\overline{\text{SCK0}}\downarrow$	t_{KSO6}	R = 1 kΩ, C = 100 pF Note	$V_{\text{DD}} = 4.5 \text{ to } 6.0 \text{ V}$	0		300	ns
				0		500	ns
$\overline{\text{SCK0}}$ rise, fall time	$t_{\text{r6}},$ t_{f6}	When using external device expansion function				160	ns
		When not using external device expansion function				1000	ns

Note R and C are the load resistance and load capacitance of the SB0 and SB1 output lines.

(b) Serial interface channel 1

(i) 3-wire serial I/O mode ($\overline{\text{SCK1}}$...Internal clock output)

Parameter	Symbol	Test Conditions	MIN.	TYP.	MAX.	Unit
$\overline{\text{SCK1}}$ cycle time	t_{KCY7}	$V_{\text{DD}} = 4.5 \text{ to } 6.0 \text{ V}$	800			ns
			1600			ns
$\overline{\text{SCK1}}$ high-/low-level width	t_{KH7}	$V_{\text{DD}} = 4.5 \text{ to } 6.0 \text{ V}$	$t_{\text{KCY7}}/2-50$			ns
	t_{KL7}		$t_{\text{KCY7}}/2-100$			ns
SI1 setup time (to $\overline{\text{SCK1}}\uparrow$)	t_{SIK7}	$V_{\text{DD}} = 4.5 \text{ to } 6.0 \text{ V}$	100			ns
			150			ns
SI1 hold time (from $\overline{\text{SCK1}}\uparrow$)	t_{KSI7}		400			ns
SO1 output delay time from $\overline{\text{SCK1}}\downarrow$	t_{KS07}	$C = 100 \text{ pF}$ Note			300	ns

Note C is the load capacitance of the $\overline{\text{SCK1}}$ and SO1 output lines.

(ii) 3-wire serial I/O mode ($\overline{\text{SCK1}}$...External clock input)

Parameter	Symbol	Test Conditions	MIN.	TYP.	MAX.	Unit
$\overline{\text{SCK1}}$ cycle time	t_{KCY8}	$V_{\text{DD}} = 4.5 \text{ to } 6.0 \text{ V}$	800			ns
			1600			ns
$\overline{\text{SCK1}}$ high-/low-level width	t_{KH8}	$V_{\text{DD}} = 4.5 \text{ to } 6.0 \text{ V}$	400			ns
	t_{KL8}		800			ns
SI1 setup time (to $\overline{\text{SCK1}}\uparrow$)	t_{SIK8}		100			ns
SI1 hold time (from $\overline{\text{SCK1}}\uparrow$)	t_{KSI8}		400			ns
SO1 output delay time from $\overline{\text{SCK1}}\downarrow$	t_{KS08}	$C = 100 \text{ pF}$ Note			300	ns
$\overline{\text{SCK1}}$ rise, fall time	t_{r8} , t_{f8}	When using external device expansion function			160	ns
		When not using external device expansion function			1000	ns

Note C is the load capacitance of the SO1 output line.

(iii) 3-wire serial I/O mode with automatic transmit/receive function ($\overline{\text{SCK1}}$... Internal clock output)

Parameter	Symbol	Test Conditions	MIN.	TYP.	MAX.	Unit
$\overline{\text{SCK1}}$ cycle time	t_{KCY9}	$V_{\text{DD}} = 4.5 \text{ to } 6.0 \text{ V}$	800			ns
			1600			ns
$\overline{\text{SCK1}}$ high-/low-level width	t_{KH9} t_{KL9}	$V_{\text{DD}} = 4.5 \text{ to } 6.0 \text{ V}$	$t_{\text{KCY9}}/2-50$			ns
			$t_{\text{KCY9}}/2-100$			ns
SI1 setup time (to $\overline{\text{SCK1}}\uparrow$)	t_{SIK9}	$V_{\text{DD}} = 4.5 \text{ to } 6.0 \text{ V}$	100			ns
			150			ns
SI1 hold time (from $\overline{\text{SCK1}}\uparrow$)	t_{KSI9}		400			ns
SO1 output delay time from $\overline{\text{SCK1}}\downarrow$	t_{KSO9}	$C = 100 \text{ pF}$ Note			300	ns
STB \uparrow from $\overline{\text{SCK1}}\uparrow$	t_{SBD}		$t_{\text{KCY9}}/2-100$		$t_{\text{KCY9}}/2+100$	ns
Strobe signal high-level width	t_{SBW}		$t_{\text{KCY9}}-30$		$t_{\text{KCY9}}+30$	ns
Busy signal setup time (to busy signal detection timing)	t_{BYS}		100			ns
Busy signal hold time (to busy signal detection timing)	t_{BYH}	$V_{\text{DD}} = 4.5 \text{ to } 6.0 \text{ V}$	100			ns
			150			ns
$\overline{\text{SCK1}}\downarrow$ from busy inactive	t_{SPS}				$2t_{\text{KCY9}}$	ns

Note C is the load capacitance of the $\overline{\text{SCK1}}$ and SO1 output lines.

(iv) 3-wire serial I/O mode with automatic transmit/receive function ($\overline{\text{SCK1}}$... External clock input)

Parameter	Symbol	Test Conditions	MIN.	TYP.	MAX.	Unit
$\overline{\text{SCK1}}$ cycle time	t_{KCY10}	$V_{\text{DD}} = 4.5 \text{ to } 6.0 \text{ V}$	800			ns
			1600			ns
$\overline{\text{SCK1}}$ high-/low-level width	t_{KH10} t_{KL10}	$V_{\text{DD}} = 4.5 \text{ to } 6.0 \text{ V}$	400			ns
			800			ns
SI1 setup time (to $\overline{\text{SCK1}}\uparrow$)	t_{SIK10}		100			ns
SI1 hold time (from $\overline{\text{SCK1}}\uparrow$)	t_{KSI10}		400			ns
SO1 output delay time from $\overline{\text{SCK1}}\downarrow$	t_{KSO10}	$C = 100 \text{ pF}$ Note			300	ns
$\overline{\text{SCK1}}$ rise, fall time	t_{R10} t_{F10}	When using external device expansion function			160	ns
		When not using external device expansion function			1000	ns

Note C is the load capacitance of the SO1 output line.

(c) Serial interface channel 2

(i) 3-wire serial I/O mode (SCK2...Internal clock output)

Parameter	Symbol	Test Conditions	MIN.	TYP.	MAX.	Unit
SCK2 cycle time	t _{KCY11}	V _{DD} = 4.5 to 6.0 V	800			ns
			1600			ns
SCK2 high-/low-level width	t _{KH11} , t _{KL11}	V _{DD} = 4.5 to 6.0 V	t _{KCY11} /2-50			ns
			t _{KCY11} /2-100			ns
SI2 setup time (to SCK2↑)	t _{SIK11}	V _{DD} = 4.5 to 6.0 V	100			ns
			150			ns
SI2 hold time (to SCK2↑)	t _{KSI11}		400			ns
SO2 output delay time from SCK2↓	t _{KSO11}	C = 100 pF Note			300	ns

Note C is the load capacitance of the SCK2 and SO2 output lines.

(ii) UART mode (Dedicated baud rate generator output)

Parameter	Symbol	Test Conditions	MIN.	TYP.	MAX.	Unit
Transfer rate		V _{DD} = 4.5 to 6.0 V			78125	bps
					39063	bps

(iii) UART mode (External clock input)

Parameter	Symbol	Test Conditions	MIN.	TYP.	MAX.	Unit
ASCK cycle time	t _{KCY12}	V _{DD} = 4.5 to 6.0 V	800			ns
			1600			ns
ASCK high-/low-level width	t _{KH12} , t _{KL12}	V _{DD} = 4.5 to 6.0 V	400			ns
			800			ns
Transfer rate		V _{DD} = 4.5 to 6.0 V			39063	bps
					19531	bps
ASCK rise, fall time	t _{RI2} , t _{FI2}	V _{DD} = 4.5 to 6.0 V, when not using external device expansion function			1000	ns
					160	ns

AC Timing Test Point (Excluding X1, XT1 Input)



Clock Timing

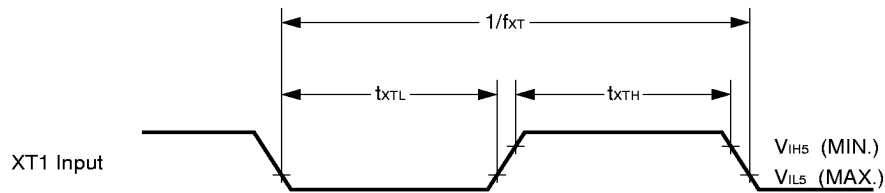
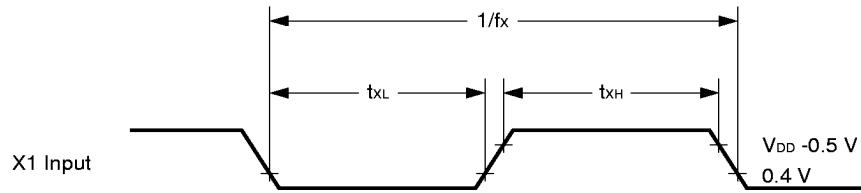

T1 Timing

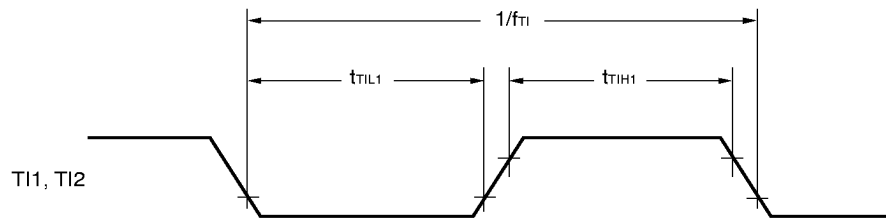
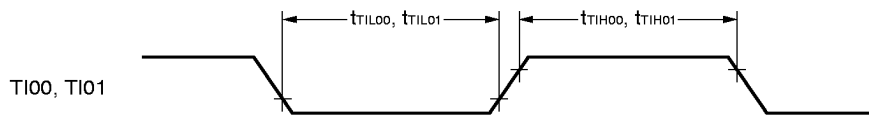

Read/Write Operation

External Fetch (No Wait) :

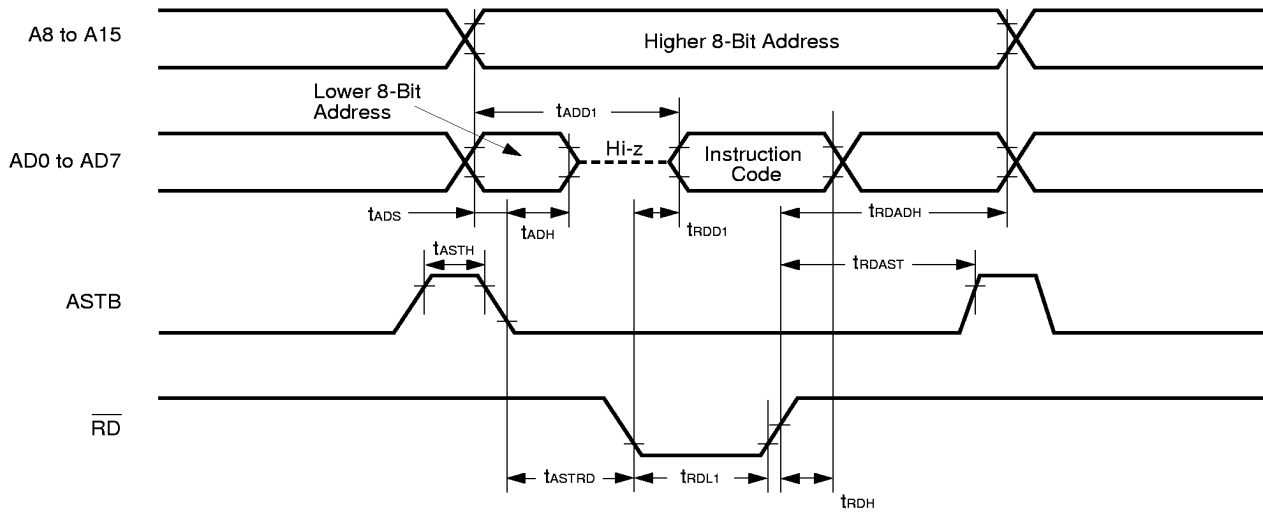

External Fetch (Wait Insertion) :

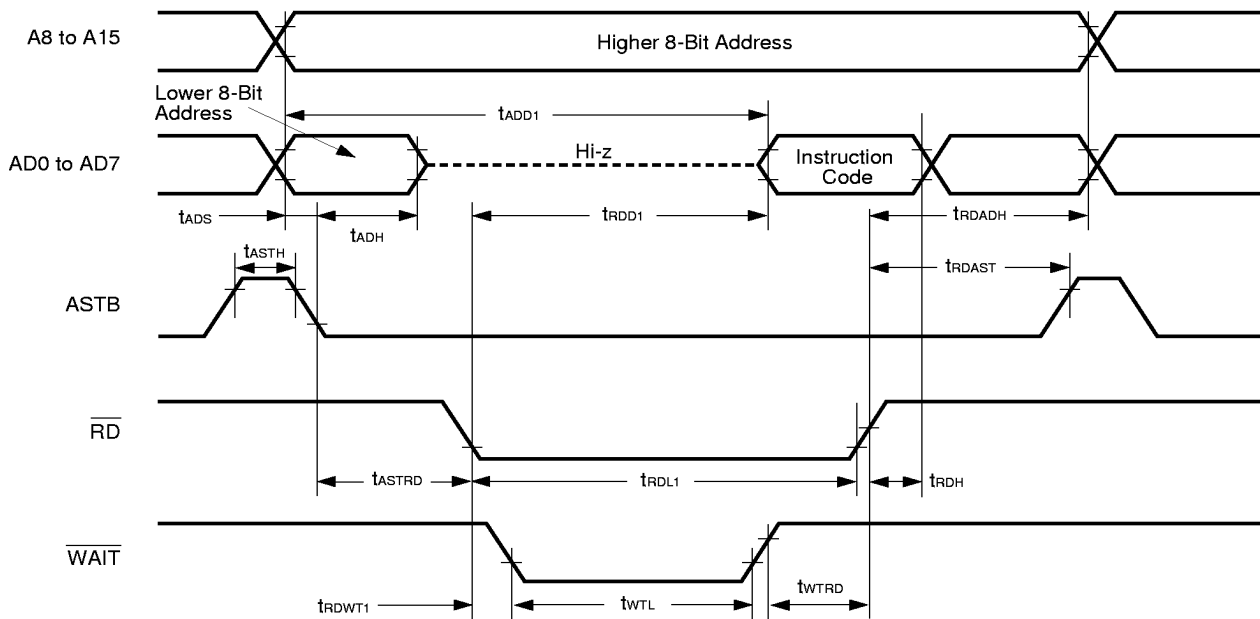

External Data Access (No Wait) :

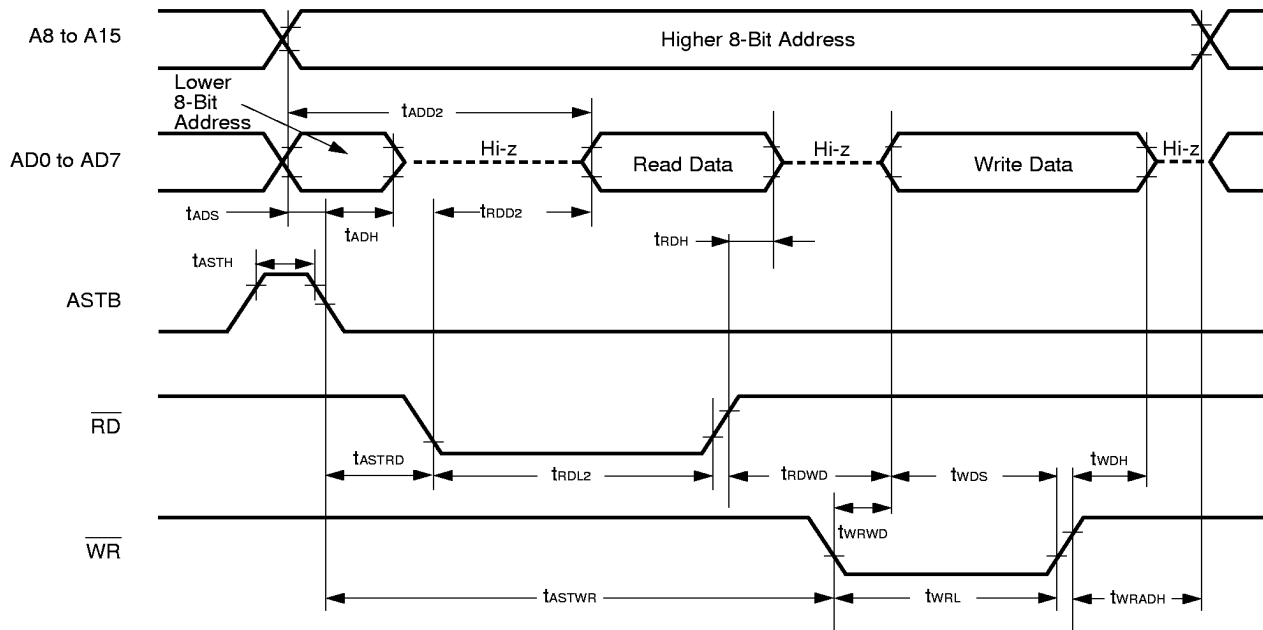

External Data Access (Wait Insertion) :

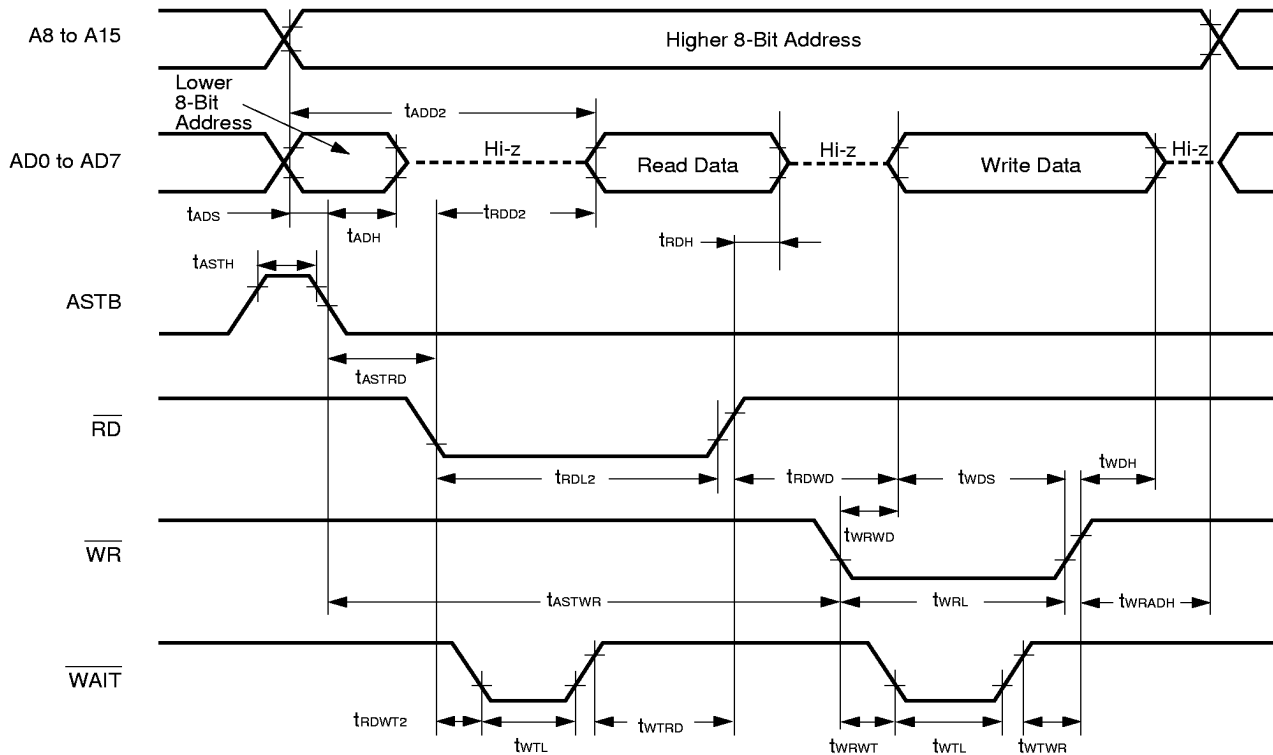

Serial Transfer Timing

3-wire Serial I/O Mode :

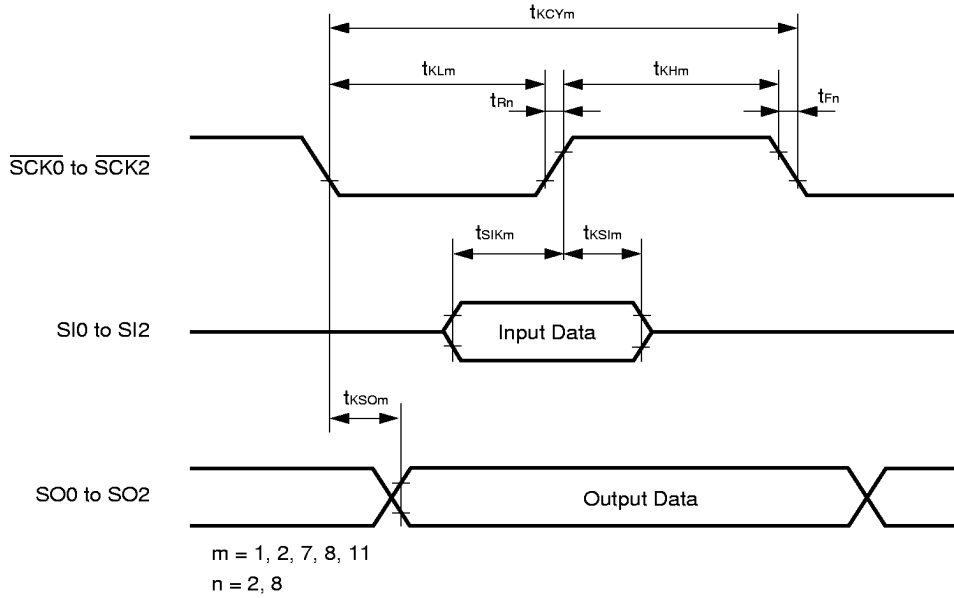

SBI Mode (Bus Release Signal Transfer) :

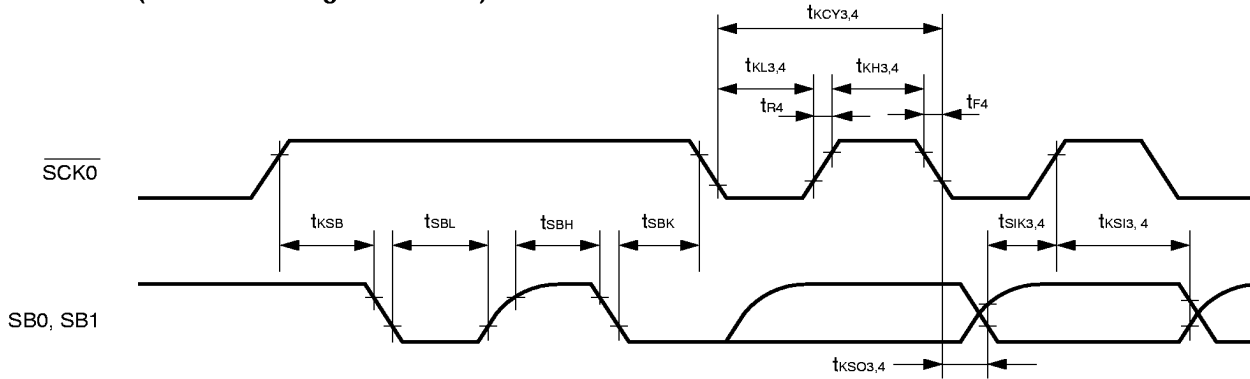

SBI Mode (Command Signal Transfer) :

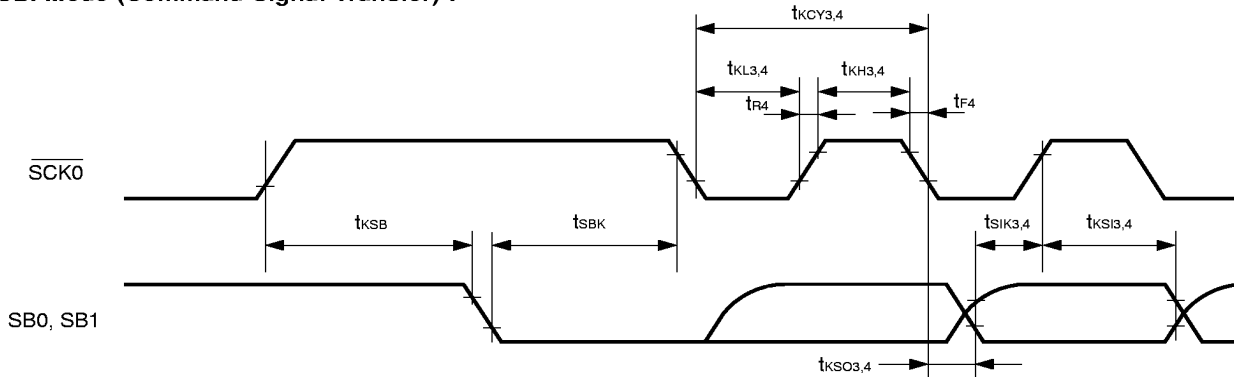

2-wire Serial I/O Mode :

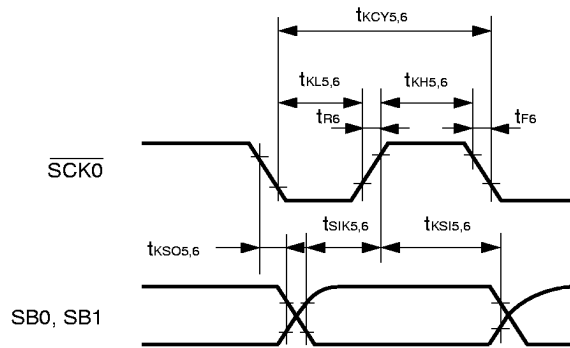

3-wire Serial I/O Mode with Automatic Transmit/Receive Function :

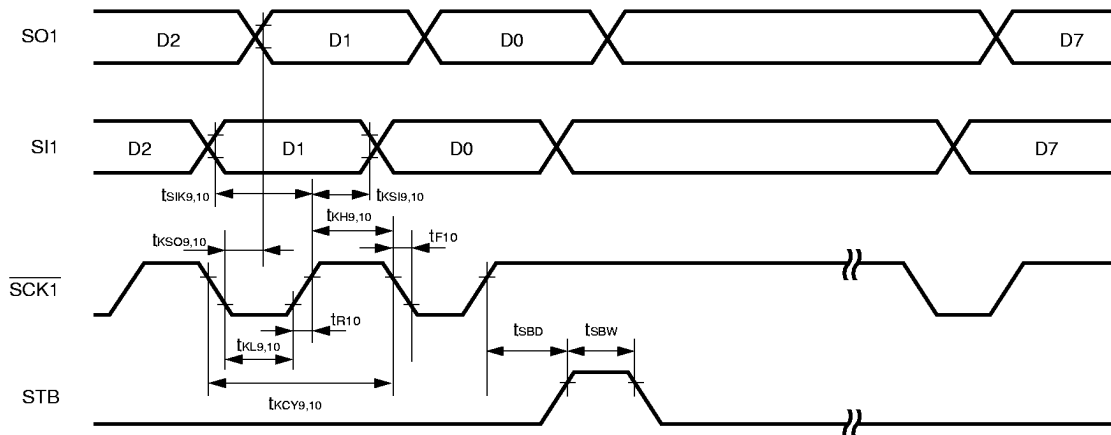

3-wire Serial I/O Mode with Automatic Transmit/Receive Function (Busy Processing) :

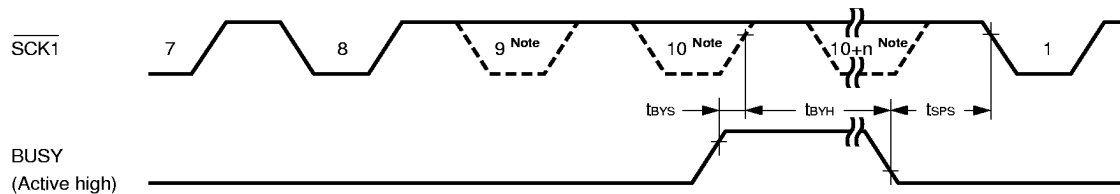

Note The signal is not actually driven low here; it is shown as such to indicate the timing.

UART Mode (External Clock Input) :

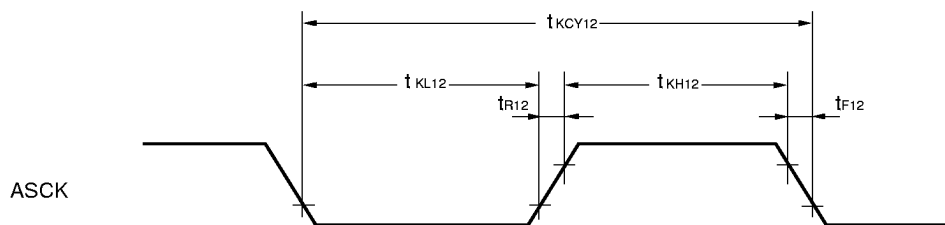

A/D CONVERTER CHARACTERISTICS (T_A = -40 to +85°C, AV_{DD} = V_{DD} = 2.7 to 6.0 V, AV_{SS} = V_{SS} = 0 V)

Parameter	Symbol	Test Conditions	MIN.	TYP.	MAX.	Unit
Resolution			8	8	8	bit
Overall error Note		2.7 V ≤ AV _{REF0} ≤ AV _{DD}			0.6	%
Conversion time	t _{CONV}		19.1		200	μs
Sampling time	t _{SAMP}		12/f _{xx}			μs
Analog input voltage	V _{IAN}		AV _{SS}		AV _{REF0}	V
Reference voltage	AV _{REF0}		2.7		AV _{DD}	V
Resistance between AV _{REF0} and AV _{SS}	R _{AIREF0}		4	14		kΩ

Note Overall error excluding quantization error (±1/2 LSB). It is indicated as a ratio to the full-scale value.

Caution For pins which also function as port pins (see 3.1 Port Pins), do not perform the following operations during A/D conversion. If these operations are performed, the total error ratings cannot be kept (except for LCD segment output alternate-function pin).

- (1) Rewrite the output latch while the pin is used as a port pin.
- (2) Change the output level of the pin used as an output pin, even if it is not used as a port pin.

Remarks

- 1. f_{xx}: Main system clock frequency (f_x or f_x/2)
- 2. f_x: Main system clock oscillation frequency

D/A CONVERTER CHARACTERISTICS (T_A = -40 to +85°C, V_{DD} = 2.7 to 6.0 V, AV_{SS} = V_{SS} = 0 V)

Parameter	Symbol	Test Conditions	MIN.	TYP.	MAX.	Unit
Resolution					8	bit
Overall error		R = 2MΩ Note 1			1.2	%
		R = 4MΩ Note 1			0.8	%
		R = 10MΩ Note 1			0.6	%
Settling time		Note 1 C=30pF	4.5 V ≤ AV _{REF1} ≤ 6.0 V		10	μs
			2.7 V ≤ AV _{REF1} < 4.5 V		15	μs
Output resistance	R _O	Note 2		10		kΩ
Analog reference voltage	AV _{REF1}		2.0		V _{DD}	V
Resistance between AV _{REF1} and AV _{SS}	R _{AIREF1}	DACS0, DACS1 = 55H Note 2	4	8		kΩ

Notes

- 1. R and C are the load resistance and load capacitance of the D/A converter output pins.
- 2. Value for D/A converter 1 channel

Remark DACS0, DACS1: D/A conversion value setting register 0, 1

Data Memory STOP Mode Low Supply Voltage Data Retention Characteristics (T_A = -40 to + 85°C)

Parameter	Symbol	Test Conditions	MIN.	TYP.	MAX.	Unit
Data retention power supply voltage	V _{DDDR}		1.8		6.0	V
Data retention power supply current	I _{DDDR}	V _{DDDR} = 1.8 V Subsystem clock stop and feed-back resistor disconnected		0.1	10	μA
Release signal set time	t _{SREL}		0			μs
Oscillation stabilization wait time	t _{WAIT}	Release by $\overline{\text{RESET}}$		2 ¹⁷ /f _x		ms
		Release by interrupt request		Note		ms

Note In combination with bits 0 to 2 (OSTS0 to OSTS2) of the oscillation stabilization time select register, selection of 2¹²/f_{xx} and 2¹⁴/f_{xx} to 2¹⁷/f_{xx} is possible.

Remark f_{xx}: Main system clock frequency (f_x or f_x/2)
f_x: Main system clock oscillation frequency

Data Retention Timing (STOP Mode Release by $\overline{\text{RESET}}$)

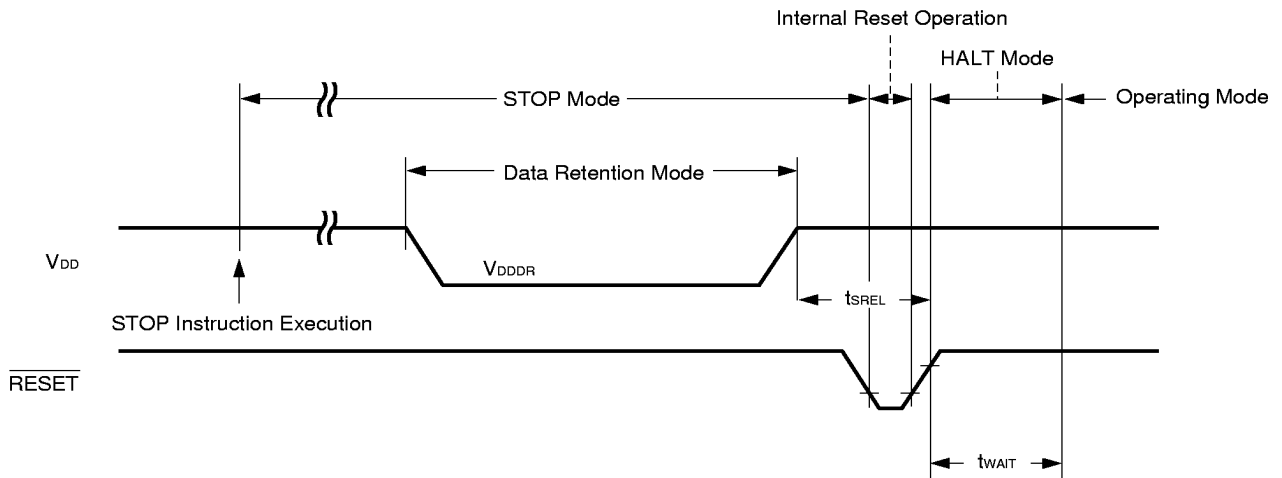

Data Retention Timing (Standby Release Signal: STOP Mode Release by Interrupt Request Signal)

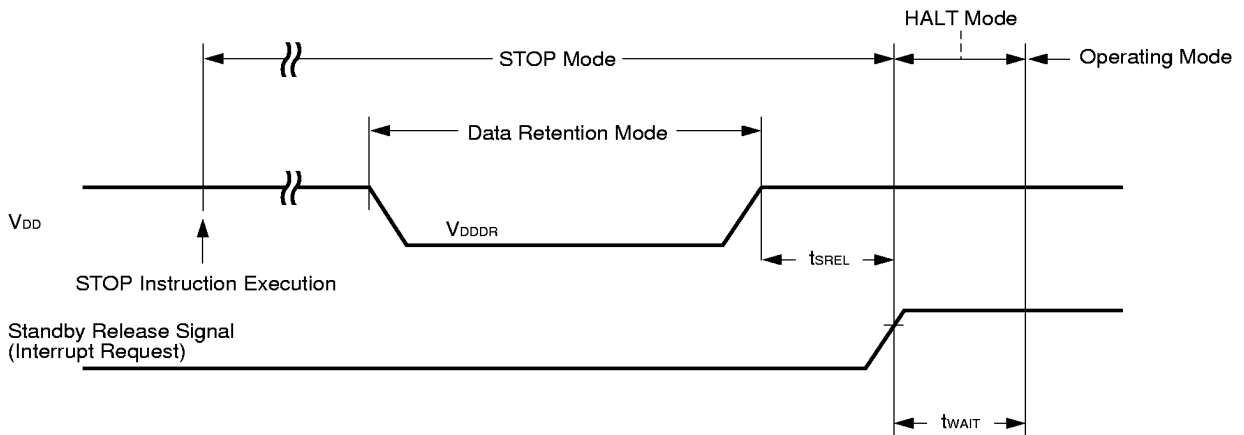

Interrupt Request Input Timing

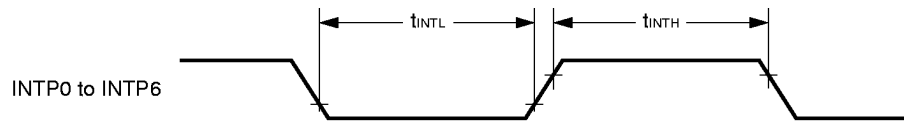

$\overline{\text{RESET}}$ Input Timing

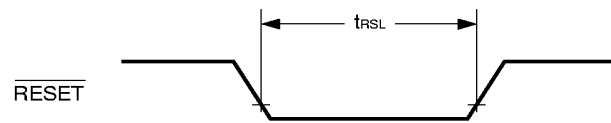

12. PACKAGE DRAWINGS

μPD78056FGC-xxx-3B9, 78058FGC-xxx-3B9

80 PIN PLASTIC QFP (14×14)

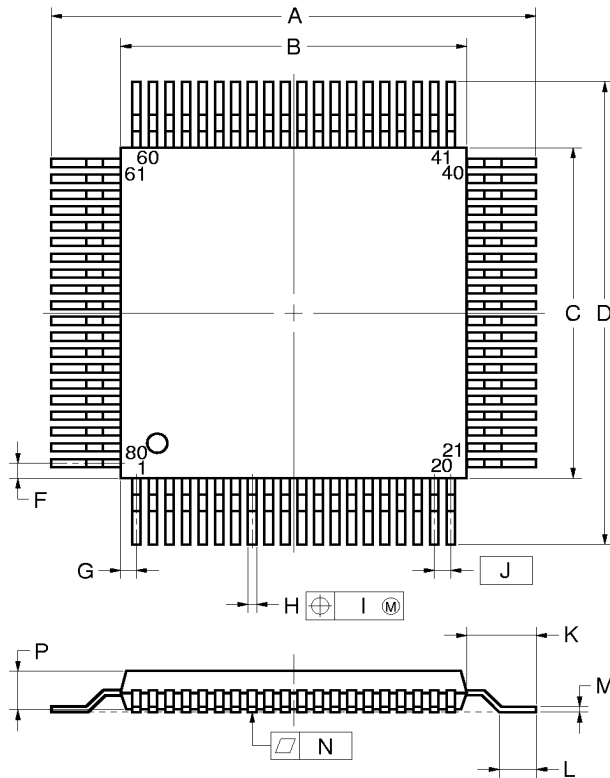

detail of lead end

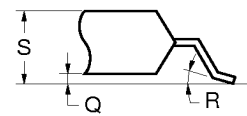

NOTE

Each lead centerline is located within 0.13 mm (0.005 inch) of its true position (T.P.) at maximum material condition.

ITEM	MILLIMETERS	INCHES
A	17.2±0.4	0.677±0.016
B	14.0±0.2	0.551 ^{+0.009} _{-0.008}
C	14.0±0.2	0.551 ^{+0.009} _{-0.008}
D	17.2±0.4	0.677±0.016
F	0.825	0.032
G	0.825	0.032
H	0.30±0.10	0.012 ^{+0.004} _{-0.005}
I	0.13	0.005
J	0.65 (T.P.)	0.026 (T.P.)
K	1.6±0.2	0.063±0.008
L	0.8±0.2	0.031 ^{+0.009} _{-0.008}
M	0.15 ^{+0.10} _{-0.05}	0.006 ^{+0.004} _{-0.003}
N	0.10	0.004
P	2.7	0.106
Q	0.1±0.1	0.004±0.004
R	5°±5°	5°±5°
S	3.0 MAX.	0.119 MAX.

S80GC-65-3B9-4

Remark Dimensions and materials of ES product are the same as those of mass-production products.

μPD78056FGC-xxx-8BT, 78058FGC-xxx-8BT

80 PIN PLASTIC QFP (14×14)

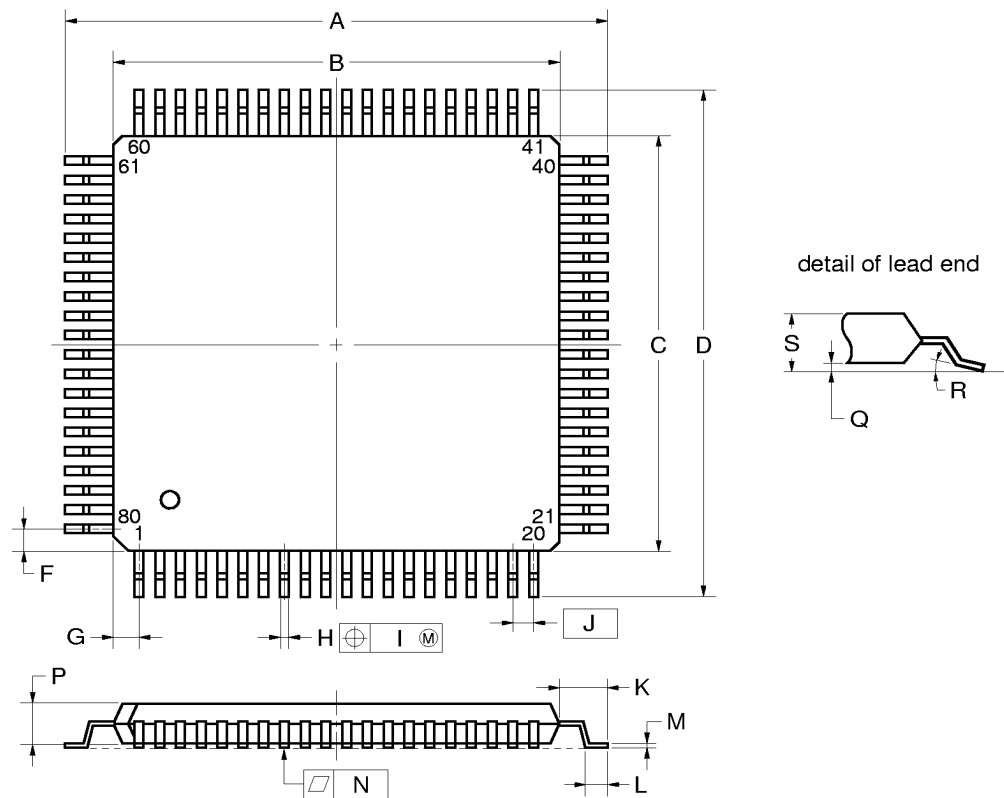

NOTE

Each lead centerline is located within 0.13 mm (0.005 inch) of its true position (T.P.) at maximum material condition.

ITEM	MILLIMETERS	INCHES
A	17.20±0.20	0.677±0.008
B	14.00±0.20	0.551 ^{+0.009} _{-0.008}
C	14.00±0.20	0.551 ^{+0.009} _{-0.008}
D	17.20±0.20	0.677±0.008
F	0.825	0.032
G	0.825	0.032
H	0.32±0.06	0.013 ^{+0.002} _{-0.003}
I	0.13	0.005
J	0.65 (T.P.)	0.026 (T.P.)
K	1.60±0.20	0.063±0.008
L	0.80±0.20	0.031 ^{+0.009} _{-0.008}
M	0.17 ^{+0.03} _{-0.07}	0.007 ^{+0.001} _{-0.003}
N	0.10	0.004
P	1.40±0.10	0.055±0.004
Q	0.125±0.075	0.005±0.003
R	3° ^{+7°} _{-3°}	3° ^{+7°} _{-3°}
S	1.70 MAX.	0.067 MAX.

P80GC-65-8BT

80 PIN PLASTIC TQFP (FINE PITCH) (12 × 12)

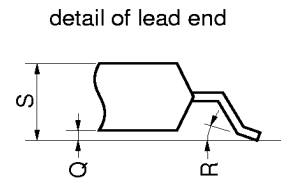
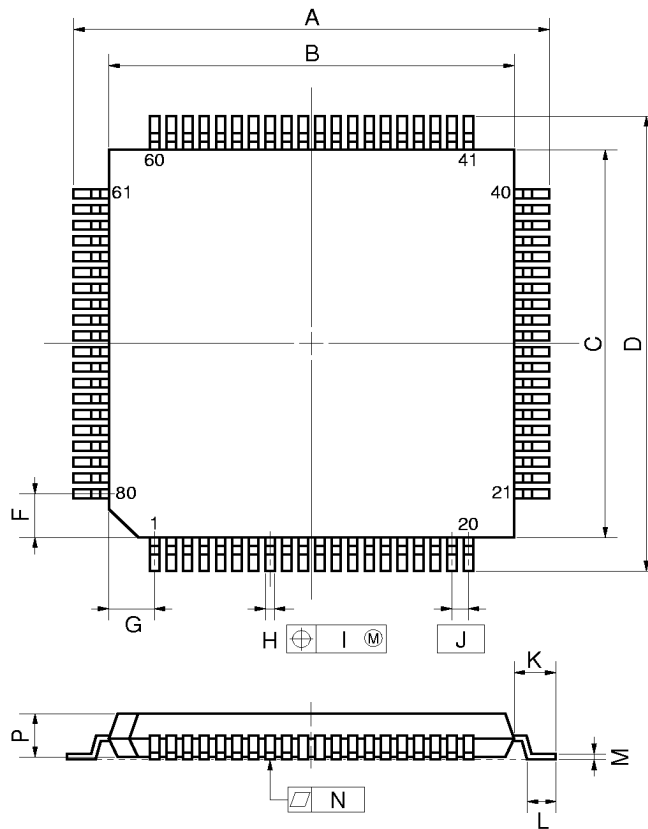

NOTE

Each lead centerline is located within 0.10 mm (0.004 inch) of its true position (T.P.) at maximum material condition.

ITEM	MILLIMETERS	INCHES
A	14.0±0.2	0.551 ^{+0.009} _{-0.008}
B	12.0±0.2	0.472 ^{+0.009} _{-0.008}
C	12.0±0.2	0.472 ^{+0.009} _{-0.008}
D	14.0±0.2	0.551 ^{+0.009} _{-0.008}
F	1.25	0.049
G	1.25	0.049
H	0.22 ^{+0.05} _{-0.04}	0.009±0.002
I	0.10	0.004
J	0.5 (T.P.)	0.020 (T.P.)
K	1.0±0.2	0.039 ^{+0.009} _{-0.008}
L	0.5±0.2	0.020 ^{+0.008} _{-0.009}
M	0.145 ^{+0.055} _{-0.045}	0.006±0.002
N	0.10	0.004
P	1.05	0.041
Q	0.05±0.05	0.002±0.002
R	5°±5°	5°±5°
S	1.27 MAX.	0.050 MAX.

P80GK-50-BE9-4

Remark Dimensions and materials of ES product are the same as those of mass-production products.

13. RECOMMENDED SOLDERING CONDITIONS

This product should be soldered and mounted under the conditions recommended in the table below.

For detail of recommended soldering conditions, refer to the information document **Semiconductor Device Mounting Technology Manual (C10535E)**.

For soldering methods and conditions other than those recommended below, contact an NEC sales representative.

Table 13-1. Surface Mounting Type Soldering Conditions (1/2)

- (1) μPD78056FGC-xxx-3B9 : 80-pin plastic QFP (14 × 14 mm, resin thickness 2.7 mm)
- μPD78058FGC-xxx-3B9 : 80-pin plastic QFP (14 × 14 mm, resin thickness 2.7 mm)

Soldering Method	Soldering Conditions	Recommended Condition Symbol
Infrared reflow	Package peak temperature: 235°C, Duration: 30 sec. max. (at 210°C or above), Number of times: Three times max.	IR35-00-3
VPS	Package peak temperature: 215°C, Duration: 40 sec. max. (at 200°C or above), Number of times: Three times max.	VP15-00-3
Wave soldering	Solder bath temperature : 260°C max., Duration : 10 sec. max., Number of times: once, Preheating temperature : 120°C max. (package surface temperature)	WS60-00-1
Partial heating	Pin temperature: 300°C max. Duration: 3 sec. max. (per pin row)	—

Caution Use of more than one soldering method should be avoided (except in the case of partial heating).

- ★ (2) μPD78056FGC-xxx-8BT : 80-pin plastic QFP (14 × 14 mm, resin thickness 1.4 mm)
- μPD78058FGC-xxx-8BT : 80-pin plastic QFP (14 × 14 mm, resin thickness 1.4 mm)

Soldering Method	Soldering Conditions	Recommended Condition Symbol
Infrared reflow	Package peak temperature: 235°C, Duration: 30 sec. max. (at 210°C or above), Number of times: Twice max.	IR35-00-2
VPS	Package peak temperature: 215°C, Duration: 40 sec. max. (at 200°C or above), Number of times: Twice max.	VP15-00-2
Wave soldering	Solder bath temperature : 260°C max., Duration : 10 sec. max., Number of times: once, Preheating temperature : 120°C max. (package surface temperature)	WS60-00-1
Partial heating	Pin temperature: 300°C max. Duration: 3 sec. max. (per pin row)	—

Caution Use of more than one soldering method should be avoided (except in the case of partial heating).

Table 13-1. Surface Mounting Type Soldering Conditions (2/2)

★ (3) μPD78058FGK-xxx-BE9: 80-pin plastic TQFP (fine pitch) (12 × 12 mm)

Soldering Method	Soldering Conditions	Recommended Condition Symbol
Infrared reflow	Package peak temperature: 235°C, Duration: 30 sec. max. (at 210°C or above), Number of times: Three times max., Time limit: 7 days Note (thereafter 10 hours 125°C prebaking required)	IR35-107-3
VPS	Package peak temperature: 215°C, Duration: 40 sec. max. (at 200°C or above), Number of times: Three times max., Time limit: 7 days Note (thereafter 10 hours 125°C prebaking required)	VP15-107-3
Partial heating	Pin temperature: 300°C max. Duration: 3 sec. max. (per pin row)	—

Note For the storage period after dry-pack decompression storage conditions are max. 25°C, 65 % RH.

Caution Use of more than one soldering method should be avoided (except in the case of partial heating).

APPENDIX A. DEVELOPMENT TOOLS

The following development tools are available for system development using the μPD78058F Subseries.

Language Processing Software

RA78K/0 Notes 1, 2, 3, 4	Assembler package common to 78K/0 Series
CC78K/0 Notes 1, 2, 3, 4	C compiler package common to 78K/0 Series
DF78054 Notes 1, 2, 3, 4	Device file common to μPD78054 Subseries
CC78K/0-L Notes 1, 2, 3, 4	C compiler library source file common to 78K/0 Series

PROM Writing Tools

PG-1500	PROM programmer
PA-78P054GC	Programmer adapters connected to PG-1500
PG-1500 controller Notes 1, 2	PG-1500 control program

Debugging Tools

	IE-78000-R	In-circuit emulator common to 78K/0 Series
	IE-78000-R-A	78K/0 Series common to in-circuit emulator (for integrated debugger)
	IE-78000-R-BK	Break board common to 78K/0 Series
	IE-78064-R-EM Note 8	Emulation board common to μPD78064 Subseries
★	IE-780308-R-EM	Emulation board common to μPD780308 Subseries
★	IE-78000-R-SV3	Interface adapter and cable when EWS is used as host machine (for IE-78000-R-A)
★	IE-70000-98-IF-B	Interface adapter when PC-9800 series (except notebook type) is used as host machine.
★	IE-70000-98N-IF	Interface adapter and cable when notebook type PC-9800 series is used as host machine.
★	IE-70000-PC-IF-B	Interface adapter when IBM PC/AT™ and compatibles are used as host machine.
	EP-78230GC-R	Emulation probe common to μPD78234 Subseries
	EP-78054GK-R	Emulation probe common to μPD78054 Subseries
	EV-9200GC-80	Socket to be mounted on the target system board manufactured for 80-pin plastic QFP (GC-3B9, GC-8BT type)
★	TGK-080SDW	Adapter to be mounted in the target system board manufactured for 80-pin plastic TQFP (GK-BE9 type) Product made by TOKYO ELETECH Corporation ((03) 5295-1661). Contact an NEC dealer regarding the purchase of this product.
	SM78K0 Notes 5, 6, 7	System simulator common to 78K/0 Series
	ID78K0 Notes 4, 5, 6, 7	Integrated debugger for IE-78000-R-A
	SD78K/0 Notes 1, 2	IE-78000-R screen debugger
	DF78054 Notes 1, 2, 4, 5, 6, 7	μPD78054 Subseries device file

Real-Time OS

RX78K/0 Notes 1, 2, 3, 4	Real-time OS for 78K/0 Series
MX78K0 Notes 1, 2, 3, 4	Real-time OS for 78K/0 Series

Fuzzy Inference Development Support System

FE9000 Note 1 / FE9200 Note 6	Fuzzy knowledge data creation tool
FT9080 Note 1 / FT9085 Note 2	Translator
FI78K0 Notes 1, 2	Fuzzy inference module
FD78K0 Notes 1, 2	Fussy inference debugger

- Notes**
1. PC-9800 series (MS-DOS™) based
 2. IBM PC/AT and compatibles (PC DOS™/IBM DOS™/MS-DOS) based
 3. HP9000 series 300™ (HP-UX™) based
 4. HP9000 series 700™ (HP-UX) based, SPARCstation™ (SunOS™) based, EWS4800 series (EWS-UX/V) based
 5. PC-9800 series (MS-DOS + Windows™) based
 6. IBM PC/AT and compatibles (PC DOS/IBM DOS/MS-DOS + Windows) based
 7. NEWS™ (NEWS-OS™) based
 8. Maintenance product

- Remarks**
1. For third party development tools, see **78K/0 Series Selection Guide (U11126E)**.
 2. The RA78K/0, CC78K/0, SM78K0, ID78K0, SD78K/0, RX78K/0 are used in combination with the DF78054.

APPENDIX B. RELATED DOCUMENTS**Device Related Documents**

Document Name	Document No. (English)	Document No. (Japanese)
μ PD78058F, 78058FY Subseries User's Manual	U12068E	U12068J
μ PD78056F, 78058F Data Sheet	This document	U11795J
μ PD78P058F Data Sheet	U11796E	U11796J
78K/0 Series User's Manual-Instruction	U12326E	U12326J
78K/0 Series Instruction Set	–	U10904J
78K/0 Series Instruction Table	–	U10903J

Caution The above related documents are subject to change without notice. Be sure to read the latest documents before designing.

Development Tool Related Documents (User's Manual)

Document Name		Document No. (English)	Document No. (Japanese)
RA78K Series Assembler Package	Operation	EEU-1399	EEU-809
	Language	EEU-1404	EEU-815
RA78K Series Structured Assembler Preprocessor		EEU-1402	U12323J
★ RA78K0 Assembler Package	Operation	U11802E	U11802J
	Assembly Language	U11801E	U11801J
	Structured Assembly Language	U11789E	U11789J
CC78K Series C Compiler	Operation	EEU-1280	EEU-656
	Language	EEU-1284	EEU-655
CC78K0 C Compiler	Operation	U11517E	U11517J
	Language	U11518E	U11518J
CC78K/0 C Compiler Application Note	Programming know-how	EEA-1208	EEA-618
CC78K Series Library Source File		–	U12322J
PG-1500 PROM Programmer		EEU-1335	U11940J
PG-1500 Controller PC-9800 Series (MS-DOS) based		EEU-1291	EEU-704
PG-1500 Controller IBM PC Series (PC DOS) based		U10540E	EEU-5008
IE-78000-R		U11376E	U11376J
IE-78000-R-A		U10057E	U10057J
IE-78000-R-BK		EEU-1427	EEU-867
IE-78064-R-EM		EEU-1443	EEU-905
★ IE-780308-R-EM		U11362E	U11362J
EP-78230		EEU-1515	EEU-985
EP-78054GK-R		EEU-1468	EEU-932
SM78K0 System Simulator, Windows based	Reference	U10181E	U10181J
SM78K Series System Simulator	External parts user open interface specification	U10092E	U10092J
ID78K0 Integrated Debugger, EWS based	Reference	–	U11151J
ID78K0 Integrated Debugger, PC based	Reference	U11539E	U11539J
ID78K0 Integrated Debugger, Windows based	Guide	U11649E	U11649J
SD78K/0 Screen Debugger PC-9800 Series (MS-DOS) based	Introduction	–	EEU-852
	Reference	–	U10952J
SD78K/0 Screen Debugger IBM PC/AT (PC DOS) based	Introduction	U10539E	EEU-5024
	Reference	U11279E	U11279J

Caution The above related documents are subject to change without notice. Be sure to read the latest documents before designing.

Embedded Software Documents (User's Manual)

Document Name		Document No. (English)	Document No. (Japanese)
78K/0 Series Real-time OS	Fundamental	U11537E	U11537J
	Installation	U11536E	U11536J
78K/0 Series OS MX78K0	Fundamental	U12257E	U12257J
Fuzzy Knowledge Data Creation Tool		EEU-1438	EEU-829
78K/0, 78K/II, 87AD Series Fuzzy Inference Development Support System Translator		EEU-1444	EEU-862
78K/0 Series Fuzzy Inference Development Support System Fuzzy Inference Module		EEU-1441	EEU-858
78K/0 Series Fuzzy Inference Development Support System Fuzzy Inference Debugger		EEU-1458	EEU-921

Other Documents

Document Name	Document No. (English)	Document No. (Japanese)
IC Package Manual	C10943X	
Semiconductor Device Mounting Technology Manual	C10535E	C10535J
Quality Grades on NEC Semiconductor Devices	C11531E	C11531J
NEC Semiconductor Device Reliability/Quality Control System	C10983E	C10983J
Electrostatic Discharge (ESD) Test	–	MEM-539
Guide to Quality Assurance for Semiconductor Devices	MEI-1202	C11893J
Microcomputer Product Series Guide	–	U11416J

Caution The above related documents are subject to change without notice. Be sure to read the latest documents before designing.