



DUAL UNIVERSAL ADVANCED TDMA/SCDMA PHY-LAYER BURST RECEIVER

FEATURES

- The BCM3140 is a universal headend advanced TDMA and SCDMA physical layer QPSK/QAM burst receiver
- DOCSIS™ 2.0 based, IEEE 802.14, DAVIC and DVB compliant
- Programmable demodulation including BPSK, QPSK, 8, 16, 32, 64, 128 and 256 QAM formats
- Variable symbol rates from 160 Kilobaud to 5.12 Megabaud providing 320 Kbps to 40 Mbps operation
- Powerful Reed-Solomon FEC decoder with byte deinterleave options for impulse/burst noise mitigation
- Burst acquisition as fast as 16 preamble symbols
- On-board 12-bit analog-to-digital converters for each channel
- Direct sampling option for DOCSIS via 12-bit digital input operating at 160 MHz with LVDS or TTL level interface options
- Powerful on-board equalizer provides ingress and adjacent channel overlap protection
- Integrated fast Fourier transform (FFT) processor with variable FFT sizes and programmable window options
- I²C or SPI-compatible microcontroller interface
- JTAG test interface
- 208-pin PQFP package
- Operates over industrial temperature range (-40 to +85C)

SUMMARY OF BENEFITS

- Presents a high-performance, integrated solution for upstream demodulation in cable over data, video, and telephony applications.
- Two independent burst receivers per package enable high-density equipment designs, reducing equipment board space requirements.
- Based on DOCSIS 2.0 standards for use in CMTS.
- Seamless integration: BCM3214 advanced CMTS DOCSIS 2.0 MAC.
- Applies to digital CATV reverse-channel receiver.
- High bps/Hz modulation enables advanced digital services over narrow RF channels.
- Includes flexible analog front end options.
- Use of on-board ADCs minimizes external components.
- Direct sampling option via external 12-bit ADC minimizes RF components.
- On-board equalizer enables operation of digital services under challenging plant conditions.
- On-chip FFT enables spectrum analysis and management of the entire upstream channel.
- Small footprint enables high-density equipment.
- Deploys advanced functions in harsh environments.
- Distributed CMTS in hybrid fiber coaxial fiber node.

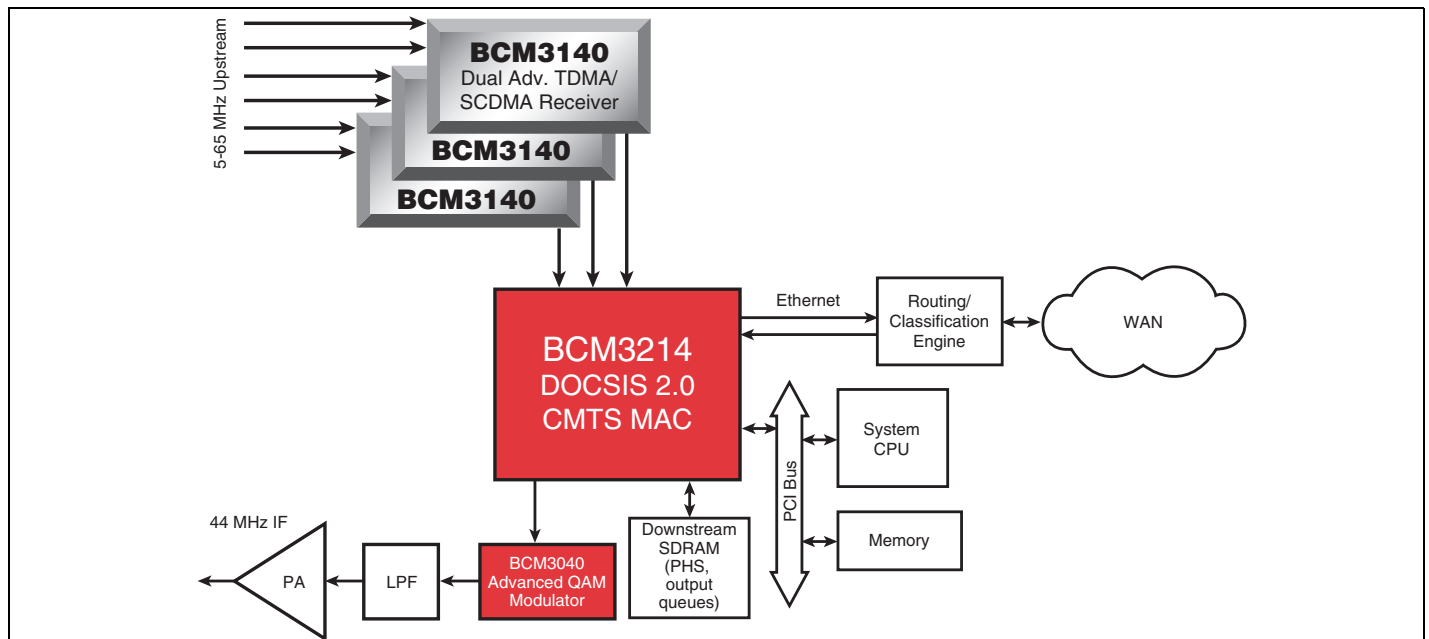

Cable Modem Termination System (CMTS) Block Diagram

OVERVIEW

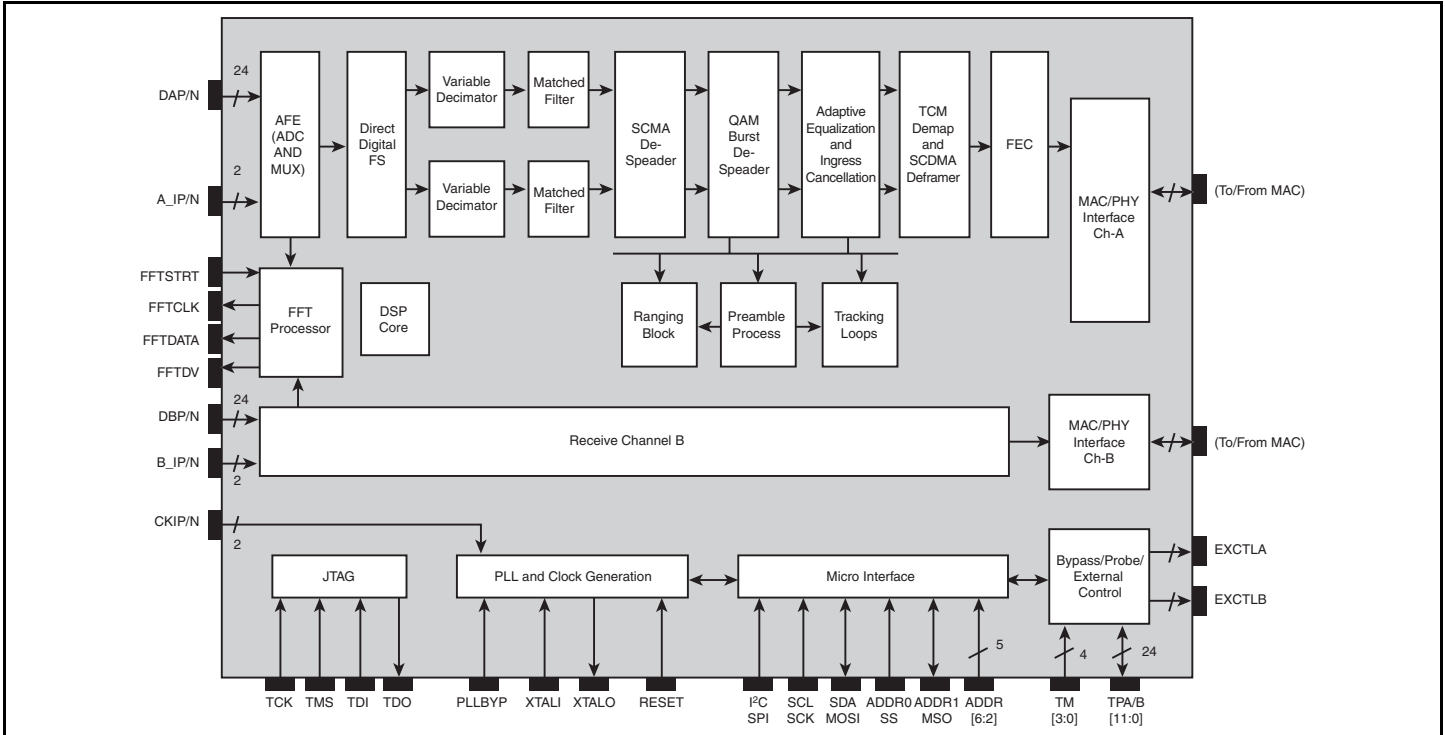

The BCM3140 QAMLink® Universal QPSK/QAM burst receiver is a highly integrated solution that significantly decreases the board space and cost of demodulators in digital cable modem headend applications. The BCM3140 provides two independent cable network receivers that accept QPSK and m-QAM burst data in TDMA or SCDMA schemes. Advanced features in the BCM3140 include an analog front end (AFE), a QAM demodulator, a generalized equalizer and an enhanced Reed Solomon (RS) FEC decoder with dynamic deinterleaving.

The AFE provides coarse gain setting and A-to-D conversion (ADC) on either an IF input or baseband I/Q inputs. When the internal ADC is bypassed, the on-chip digital mixer translates the desired signal at RF to true DC where the I and Q samples pass through variable decimators and matched raised-cosine filters. The BCM3140 incorporates unique word detections of programmable length and pattern in the burst preamble for signal acquisition as fast as 16 symbols. An adaptive equalizer and ingress canceller characterizes the RF channel response, cancels ingress noise and removes intersymbol interference (ISI) caused by microreflections in the channel. The FEC decoder consists of a

programmable derandomizer, a programmable RS decoder with T values programmable up to 16 and a byte deinterleaver with burst-by-burst reconfiguration capability.

The BCM3140 delivers the recovered data stream and accepts receiver control inputs through a receive interface linked to a DOCSIS MAC chip such as the BCM3214. The BCM3140 prepends ranging and data information to each received code word and packet for processing by the BCM3214. The BCM3140 can be configured through either an SPI or I2C-compatible serial interface.

The BCM3140 is a highly integrated, mixed-signal and cost-effective device providing a worldwide solution for burst receiver applications. The dual receiver design of the BCM3140 is packaged in a 208-pin PQFP, enabling a significant increase upstream channel density for headend based CMTS equipment. The BCM3140, combined with the BCM3040 QAMLink® Universal Modulator and the BCM3214 Advanced QAMLink® CMTS MAC, provides a complete solution for advanced cable headend equipment.

Broadcom®, the pulse logo, and Connecting everything® are trademarks of Broadcom Corporation and/or its subsidiaries in the United States and certain other countries. All other trademarks mentioned are the property of their respective owners.

Connecting
everything®



BROADCOM CORPORATION
16215 Alton Parkway, P.O. Box 57013
Irvine, California 92619-7013

© 2004 by BROADCOM CORPORATION. All rights reserved.

3140-PB02-R 07/01/04

Phone: 949-450-8700
Fax: 949-450-8710
E-mail: info@broadcom.com
Web: www.broadcom.com