

Agilent HSDL-D100-001/002, HSDL-D110-002 IrDA Smart Dongle

Data Sheet

Introduction

Agilent Smart Dongle is a comprehensive hardware plus software platform designed to quickly enable wireless Infrared communication. Smart Dongle support wide range of customizable IrDA applications such as IrFM Financial Payment services, picture and music file transfers between mobile devices, kiosk and interactive posters data distribution. It complies with the IrDA SIR specification and support data rate from 9600bps to 115.2kbps.

Smart Dongle position itself as the comprehensive solution to rapidly enable IrDA wireless communication in devices. Smart Dongle can be customized into an IrFM Smart Dongle for financial payment applications, OBEX Smart Dongle for music, picture files or any generic data file transfer application.

Agilent IrDA Smart Dongle Family offers various hardware plus software platforms to meet different application requirement and complexity.

HSDL-D100-001 Smart Dongle is an entry-level solution designed for simple object transfers. It can be integrated into devices, such as musical instruments to provide wireless connectivity for music sharing with mobile phones. The more sophisticated HSDL-D100-002 and HSDL-D110-002 have greater computing-power and memory resources for more complex and versatile applications, like IrFM financial payment services.

Agilent IrDA Smart Dongles are bundled with user-friendly “Smart Dongle Flash Utility” that facilitates On-the-fly firmware updating in 6 easy steps from a PC. Easy firmware updating allows Smart Dongles to be readily upgraded even after product market release.

The HSDL-D100-001 and HSDL-D100-002 comes with in sub-assembly Printed Circuit Board (PCB) module, while the HSDL-D110-002 comes complete in stylish mechanical casing.

System Overview

Agilent IrDA Smart Dongles are microcontroller-based standalone system, complete with standard embedded IrDA protocol stack with IrOBEX and support optional application programs such as the IrFM Profile, OBEX Server and OBEX Client. Smart Dongles handle IrDA communication between interfacing terminals transparently, without the need for constant host supervision.

Smart Dongles are connected to host terminals using 3-wire Null-Modem serial interface. The Serial Interface connection is used for transferring data as well as command and control. The serial interface is also used for firmware updating from a connected PC with the Smart Dongle Flash Utility.



HSDL-D100-001 Smart Dongle

The HSDL-D100-001 Smart Dongle uses a small form-factor, single chip MCU solution for basic standard application such as data object transfer using the IrOBEX Profile. It comes with two memory options: 2KB RAM + 32KB Flash (standard), and 4KB RAM + 64KB Flash (optional). Figures 1 and 3 show the HSDL-D100-001 Smart Dongle System Block Diagram and Software Structure, respectively.

The HSDL-D100-001 software supports core IrDA protocol stack, IrOBEX, and basic host serial interface software module. Core IrDA protocol stack handles low-level baud rate negotiation, exchange of connection configuration parameters, data integrity check, link management etc, relieving host terminal from such low-level IrDA transaction.

This platform is equipped with a 3-wire Serial Interface Port (UART) for interfacing to a host device. Table 1 and Figure 2 show the pin definitions for HSDL-D100-001. TXD and RXD pins are designed for direct connection to UART port of host system. Pin signals do not go through a Level Shifter nor provide RS-232 compliant voltage.

The power is supply from the host system through the +3.3V connector pin.

HSDL-D100-001 Smart Dongle support a range of host interface communication speed (baud rate) from 9600bps to 115.2kbps.

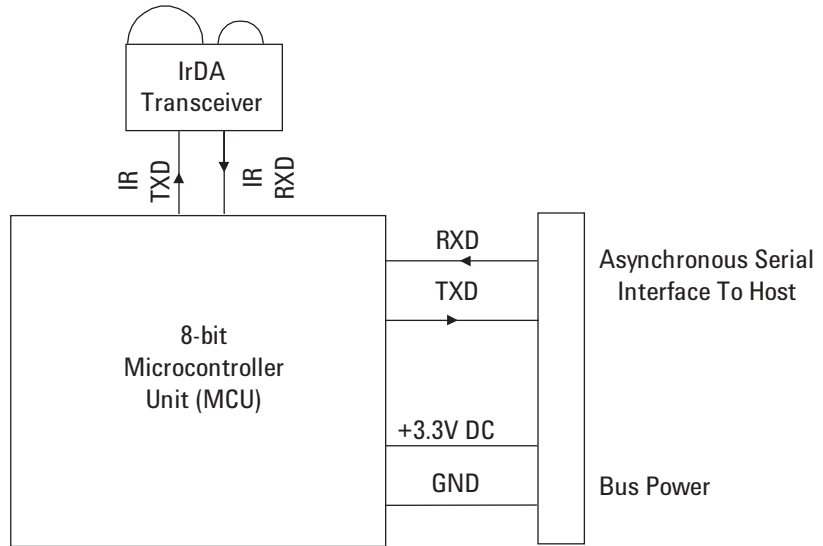

Figure 1. HSDL-D100-001 Smart Dongle Hardware Block Diagram

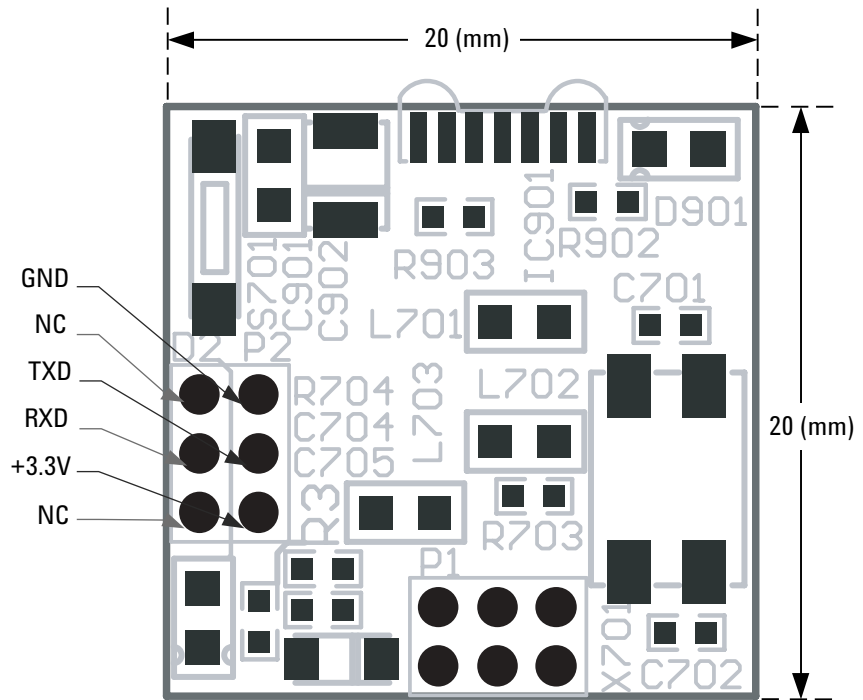

Figure 2. HSDL-D100-001 Smart Dongle PCB Layout and Interface Connection

Table 1. HSDL-D100-001 Smart Dongle interface signal with host system

Signal Connection	Description
TXD	Transmit Pin (with respect to Smart Dongle) for serial interface to host
RXD	Receive Pin (with respect to Smart Dongle) for serial interface to host
+3.3V	Bus Power Supply DC +3.3V
GND	Common System Ground with host
NC	No Connection

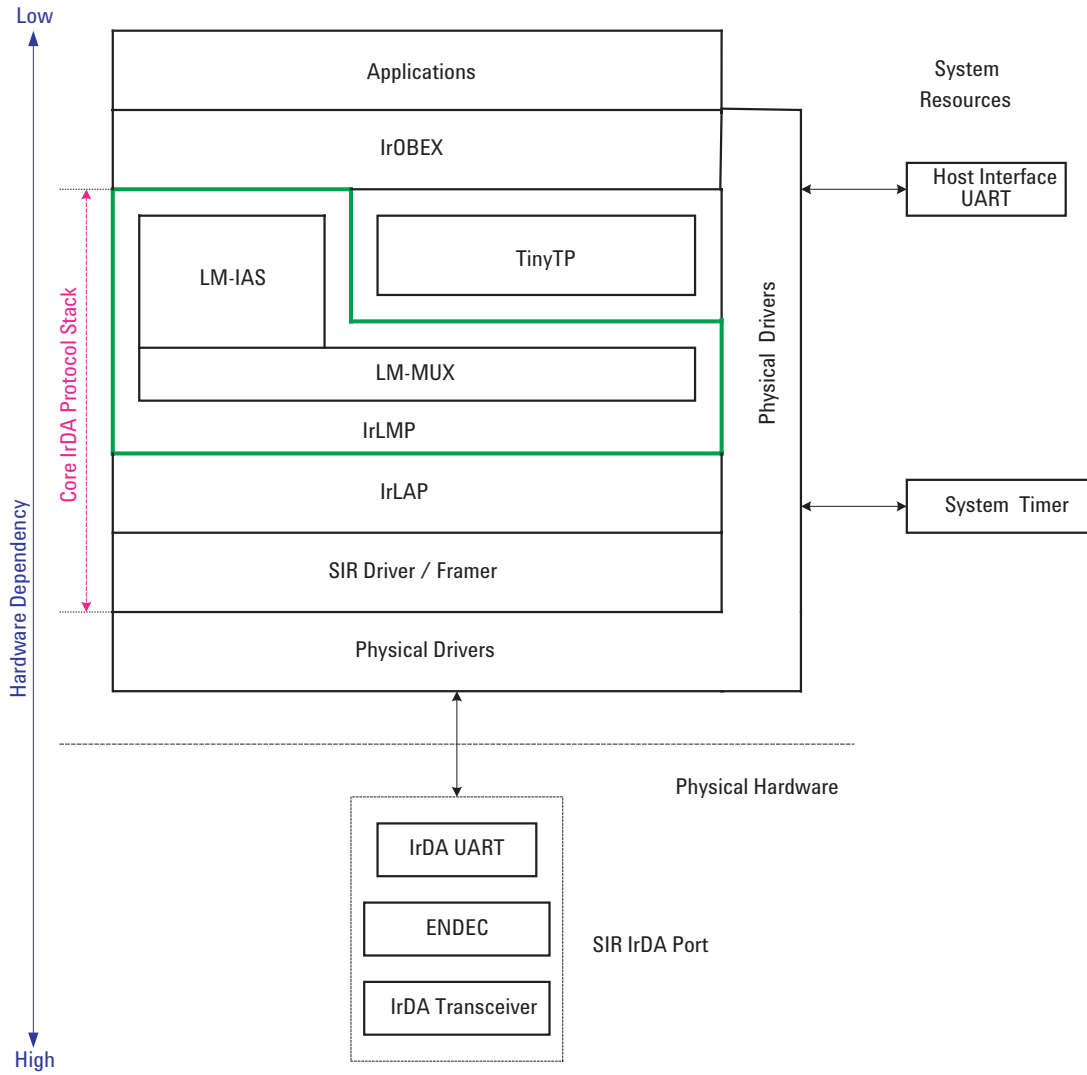

Figure 3. HSDL-D100-001 Smart Dongle Software Structure

HSDL-D100-002 / HSDL-D110-002 Smart Dongle

The mid-end HSDL-D100-002/HSDL-D110-002 Smart Dongle uses ARM7TDMI MCU solution with a default 256KB flash memory and 32KB program memory on chip. 512KB flash memory is optional and a further RAM expansion option allows 128KB or 512KB to be added. Figure 4 and 5 illustrate the System Block Diagram and Software Structure respectively for the mid-end HSDL-D100-002/HSDL-D110-002 Smart Dongle.

The platform supports core IrDA protocol stack, IrSock, IrOBEX, IrFM, host serial interface software module and a wide range of user applications. Core IrDA protocol stack relieve host system of baud rates negotiation, connection configuration exchange, data integrity check, link management and other low-level IrDA transaction.

Note that the standard applications embedded in HSDL-D100-002 and HSDL-D110-002 include the Core IrDA Protocol Stack and IrOBEX for simple file transfer operation.

The HSDL-D100-002/HSDL-D110-002 Smart Dongle comes with a RS-232 compliant serial port, using the 3-wire interface through a RS-232 Level Shifter. This serial port can be connected to a typical Male DB9 connector (shown in Figure 6), or to a 2.54mm pitch, 90° Bend Header as illustrated in Figure 6. Table 3 illustrates the interface signal for HSDL-D100-002 and HSDL-D110-002.

A range of host interface baud rates from 9600bps to 115.2kbps is supported. Host interface baud rate is specified by configuring Jumper Setting located on the bottom side of the PCB as illustrated in Figure 7. Table 2 illustrates the Jumper setting for the supported baud rate. The serial port is also used for firmware update. Description on the firmware update will be presented in the Smart Dongle Flash Utility Section.

Bus Power can be supplied from the host system to the “Bus Power” pin through the DB9 connector or the 2.54mm pitch, 90° Bend Header. Alternatively, power can also be supplied through the DC Jack connector.

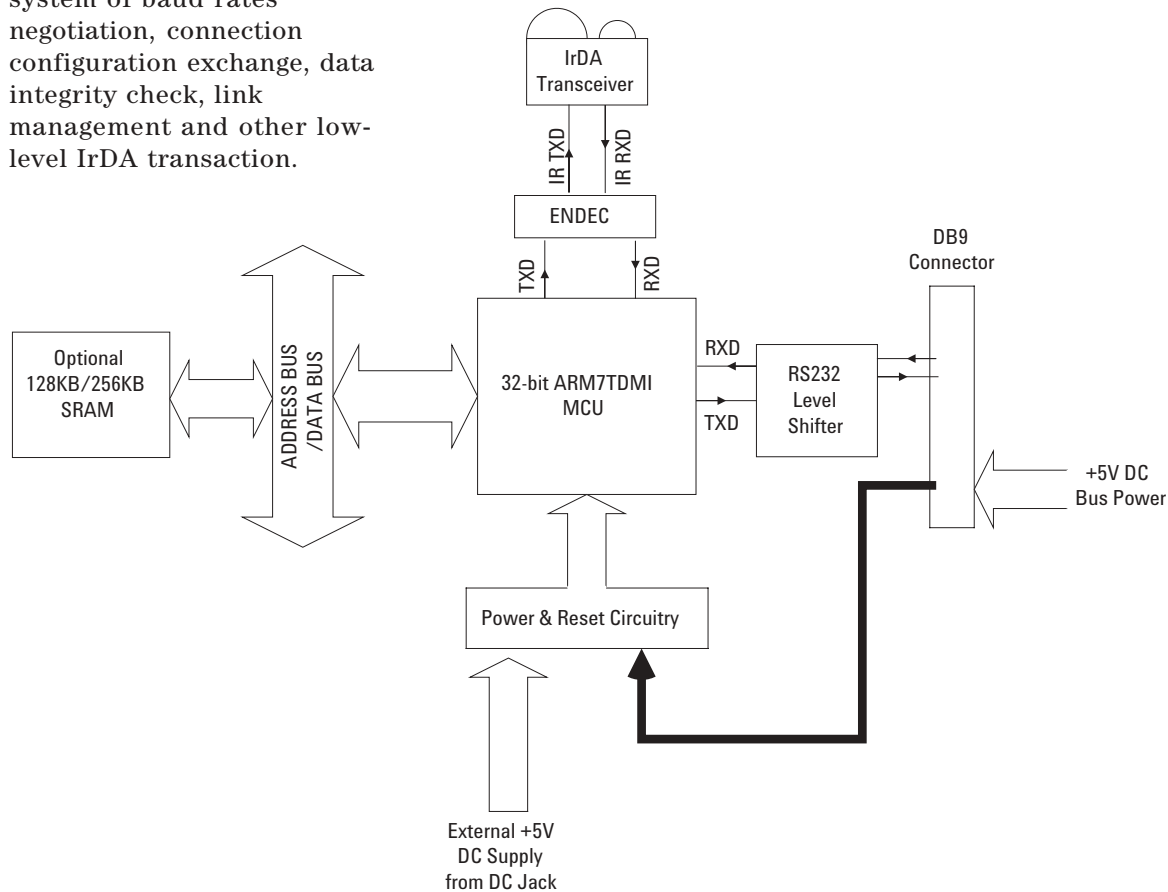

Figure 4. HSDL-D100-002/ HSDL-D110-002 Smart Dongle Hardware Block Diagram

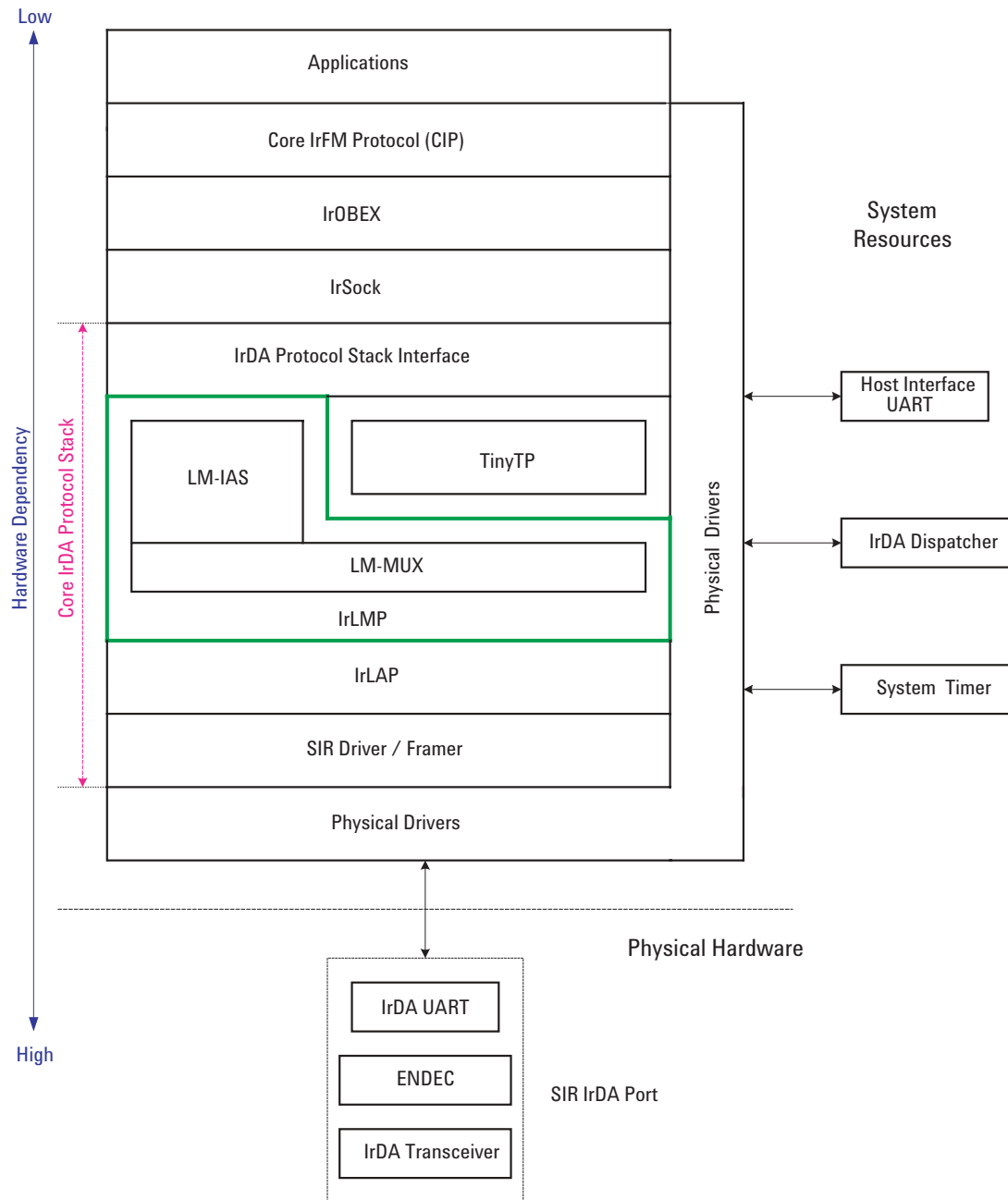

Figure 5. HSDL-D100-002/ HSDL-D110-002 Smart Dongle Software Structure for IrFM Application

Table 2. Jumper setting for setting Host Interface baud rate

Baud Rate (bps)	R803	R805	R807
9600 (Default Setting)	Open	Open	Open
19200	Open	Open	Close
38400	Open	Close	Open
57600	Open	Close	Close
115200	Close	Open	Open

Notes:

1. Open – Leave the Jumper pad as open circuit
2. Close – Short the Jumper pad with a 0Ω (0603 Case Size) resistor
3. Setting other than those defined in Table 2 put the communication link into an indeterminate state.
4. The baud rate jumper setting have no effect during firmware update.

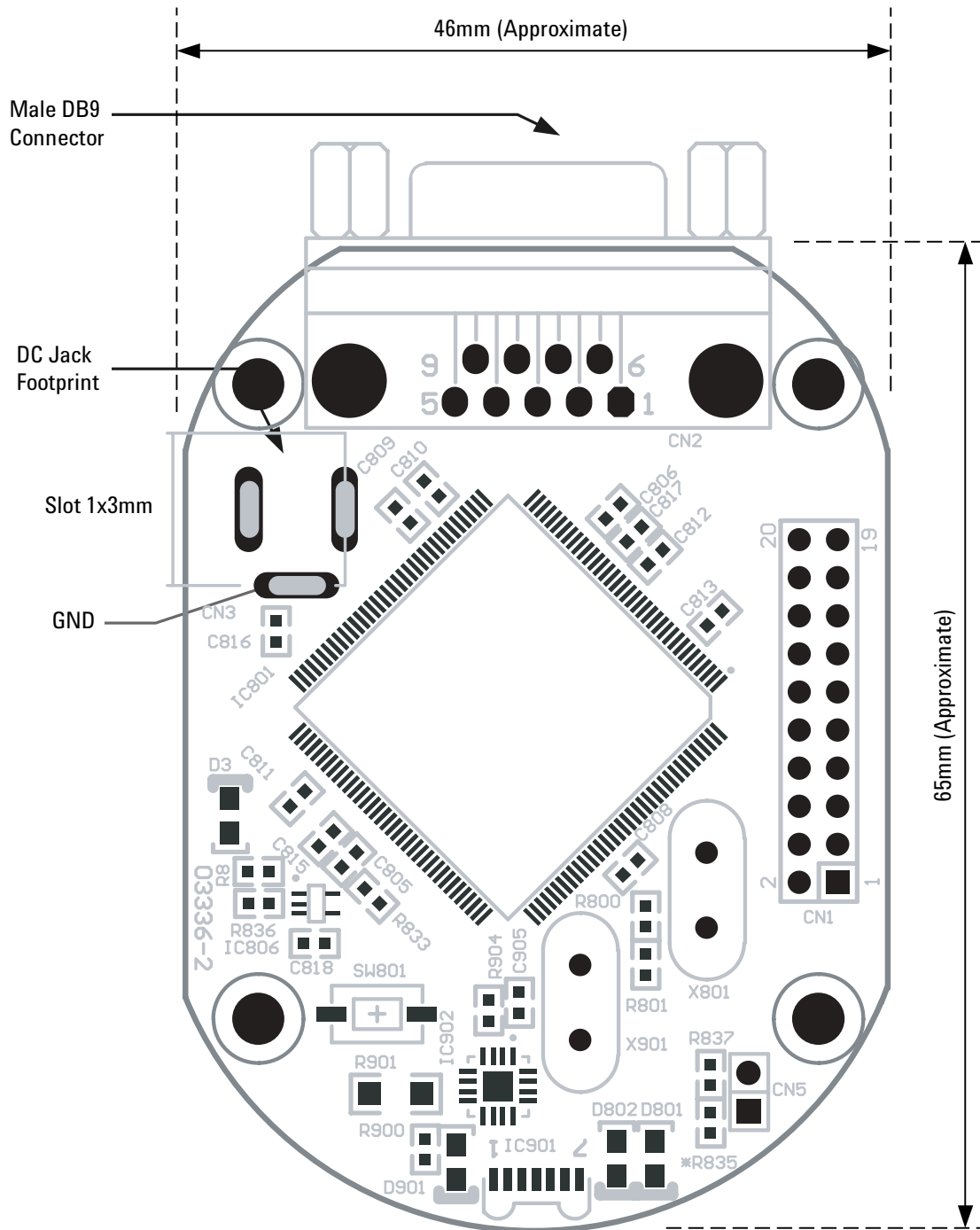

Figure 6. HSDL-D100-002/ HSDL-D110-002 Smart Dongle Top Layer PCB Layout and Interface Connection

Table 3. HSDL-D100-002/ HSDL-D110-002 Smart Dongle DB9 interface signal with host system

DB9 Connector	Signal Connection	Description
1	NC	No Connection
2	RXD	Receive Pin (with respect to Smart Dongle) for serial interface to host
3	TXD	Transmit Pin (with respect to Smart Dongle) for serial interface to host
4	NC	No Connection
5	GND	System Ground from host system
6	NC	No Connection
7	NC	No Connection
8	Programming	This pin is used for updating the firmware and should be left open. Do Not Connect any signal to this pin during normal operation. Operation is not guaranteed when this pin is connected to this signal.
9	Bus Power	Power supply from Host system DC+5V ~ DC+8V

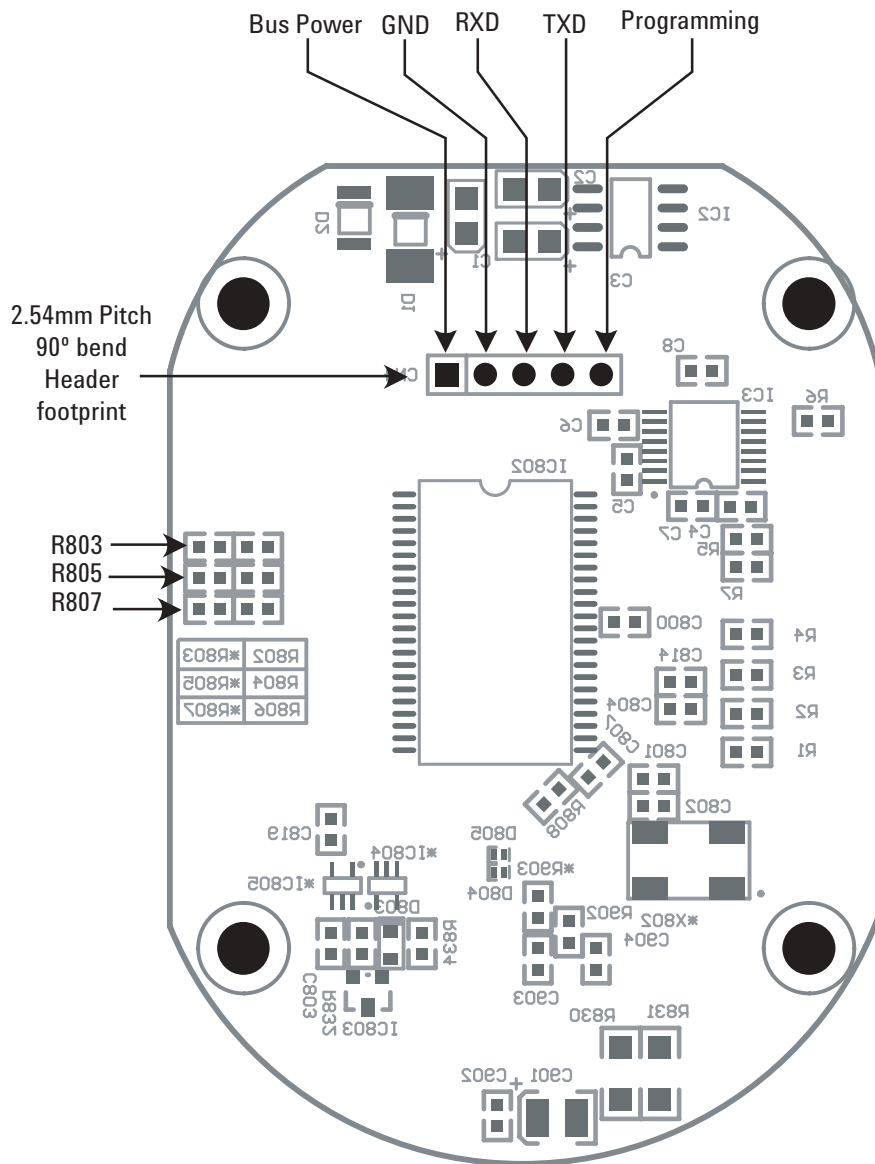

Figure 7. HSDL-D100-002/ HSDL-D110-002 Smart Dongle Bottom Layer PCB Layout and Interface Connection

Smart Dongle Flash Utility

Agilent IrDA Smart Dongles feature On-the-fly Firmware Updating through a Host Interface UART with the external DC Jack power supply.

The Smart Dongle Flash Utility works on Windows 2000/NT/XP PC. It updates Smart Dongle firmware through the PC RS-232 serial port. There are two versions of the flash utility – one for HSDL D100-002 & HSDL D110-002 (see figure 8), another for HSDL D100-001 (see figure 9).

Smart Dongle Flash Utility is designed for ease of use. A six-steps updating procedure can easily be performed by end-user. Smart Dongle has a firmware corruption protection feature. In the event of a power failure during firmware updating, Smart Dongle can reliably restart and set to programming state, when updating can be tried again.

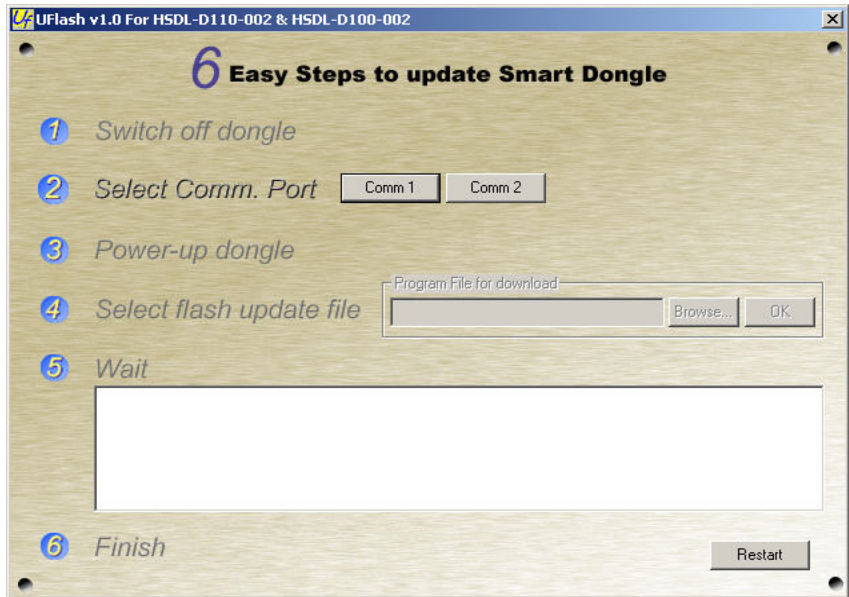

Figure 8. Screen shot of the HSDL-D100-002/HSDL-D110-002 Smart Dongle Flashing Utility

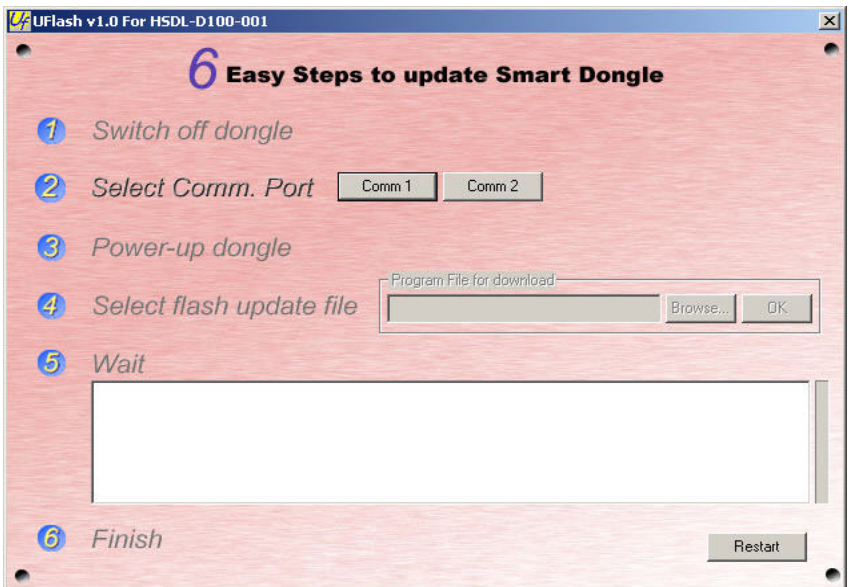

Figure 9. Screen shot of the HSDL-D100-001 Smart Dongle Flashing Utility

Table 4. Comparison between HSDL-D100-002/HSDL-D110-002 and HSDL-D100-001 Smart Dongle

Specification	Mid-End Smart Dongle HSDL-D100-002/ HSDL-D110-002	Low-End Smart Dongle HSDL-D100-001	Remarks
Hardware Platform	32-bit ARM7TDMI MCU	8-bit CISC MCU	
Internal Flash Memory	256KB / 512KB(Max)	32KB / 64KB(Max)	64KB Flash is optional
Internal RAM Size	32KB	2KB / 4KB(Max)	4KB RAM is optional
CPU Operating Speed	29.4912MHz	18.432MHz	
RAM Expansion Option	128KB / 512KB(Max)	None	Note 1
Typical Operating Voltage	DC +7.5V (DC Jack or Bus Power)	DC +3.3V (Bus Power)	
Max Operating Voltage	+8V	Fixed +3.3V	
Min Operating Voltage	+5V	Fixed +3.3V	
Operating Current	100mA (Max)	50mA (Max)	
IrDA Range	30cm	30cm	Note 7
PCB Board Size	46mm x 65mm (Approximate)	20mm x 20mm	Note 2
Mechanical Casing Included	For HSDL-D110-002 only	No	
Host Interface	3-wire RS-232 compliance with DB9 Male Connector or Standard 2.54mm pitch, 90' Bend Header	3-wire Asynchronous Serial Interface Standard 2x3 1.27mm pitch, 90' Bend Header	Note 3
On-the-fly firmware upgrade	Yes. Bundled with Smart Dongle Flash Utility	Yes. Bundled with Smart Dongle Flash Utility	Flash from PC with RS-232. Note 8
IrDA Software Characteristics			
IrDA Speed (SIR)	9.6/19.2/38.4/57.6/115.2 (kbps)	9.6/19.2/38.4/57.6/115.2 (kbps)	
Windows Size	Variable: 1,2,3,4,5,6 or 7	Fix: 1	Note 4
Data Size	Variable: 64, 128, 256, 512 or 1024 bytes	Variable: 64, 128 or 256 bytes	Note 5
IrSock	Supported	Not Available	Note 6
IrOBEX	Supported	Supported	
IrFM	Supported (Optional)	Not Available	

Notes:

- External RAM is optional. Not included in standard package.
- Applicable only to sub-assembly module.
- For Asynchronous Serial Interface, RS-232 Level Shifter IC and DB9 connector are excluded.
- Max Windows Size varies between applications and available memory.
- Max Data Size varies between applications and available memory.
- For HSDL-D100-001 Smart Dongle, application has no access to the IrSock APIs, as this layer will not be available in the dongle protocol stack. Application needs to be highly customized to provide IrOBEX compatibility. Moreover, due to limited memory, the dongle is suitable for basic application such as OBEX file transfer with limited room for future upgrading/enhancement.
- The link distance indicated does not take into account influence of windows design.
- Hardware optional accessories, which is not included in the standard package, might be needed.

Product Features**HSDL-D100-001**

Supply Voltage: Regulated +3.3V

Operating Current: 50mA(Max)

System Clock: 18.432 MHz

SIR IrDA Data Compliant 115.2kbps

Controller	8-bit Microcontroller
Memory	32KB On-chip Flash ROM (Standard) 2KB On-chip SRAM OR 64KB On-chip Flash ROM (Optional) 4KB On-chip SRAM
Peripherals	Microcontroller with dual UARTs and IrDA Interface IrDA transceiver compliant to Physical Layer Specifications version 1.4 Low Power
Operating Temperature	0°C To 70°C Celsius
Host Interface	3-wire Null Modem RS232 port Baud Rate – Standard 9600bps, Maximum 115.2kbps Data Size - 8-bit data Parity - No parity bit Stop Bit - 1 stop bit
Standard Software	Core IrDA Protocol Stack with basic IrOBEX file transfer application.

HSDL-D100-002/HSDL-D110-002

Supply Voltage: DC +5V to +8V

Operating Current: 100mA(Max)

System Clock: 29.4912MHz

SIR IrDA Data Compliant 115.2kbps

Controller	32-bit ARM Microcontroller Unit
Memory	256KB On-chip Flash ROM (Standard) 32KB On-chip SRAM OR 512KB On-chip Flash ROM (Optional) 32KB On-chip SRAM
Peripherals	Microcontroller with dual UARTs IrDA transceiver compliant to Physical Layer Specifications version 1.4 Low Power
Operating Temperature	0°C To 70°C Celsius
POS/CAT Host Interface	3-wire Null Modem RS232 port Baud Rate – Standard 9600bps, Maximum 115.2kbps Data Size - 8-bit data Parity - No parity bit Stop Bit - 1 stop bit
Standard Software	Core IrDA Protocol Stack with basic IrOBEX file transfer application.



Application Notes: Implementing HSDL-D100-002/ HSDL-D110-002 Smart Dongle for IrFM

HSDL-D100-002/ HSDL-D110-002 Smart Dongle can be customized to a wide range of devices including IrFM application. In IrFM application, Agilent Smart Dongle replaces the physical card reader that connects to a POS. Figure 10 shows Smart Dongle being used in an IrFM setup.

electronic credit card information from mobile devices like from mobile phones and Personal Digital Assistants (PDA). Digital receipt is then issued and consumer can manage them with Personal Financial Management Tools.

IrFM version of Agilent IrDA Smart Dongle can be customized for such financial payment. Smart Dongle can handle IrFM services internally, requiring no modification of POS host terminal to enable existing Point of Sale (POS) terminals.

The IrFM (Infrared Financial Messaging) profile is a quick and seamless digital payment system for infrared enabled devices and Point of Sales (POS) Terminals. Financial payment begins by beaming

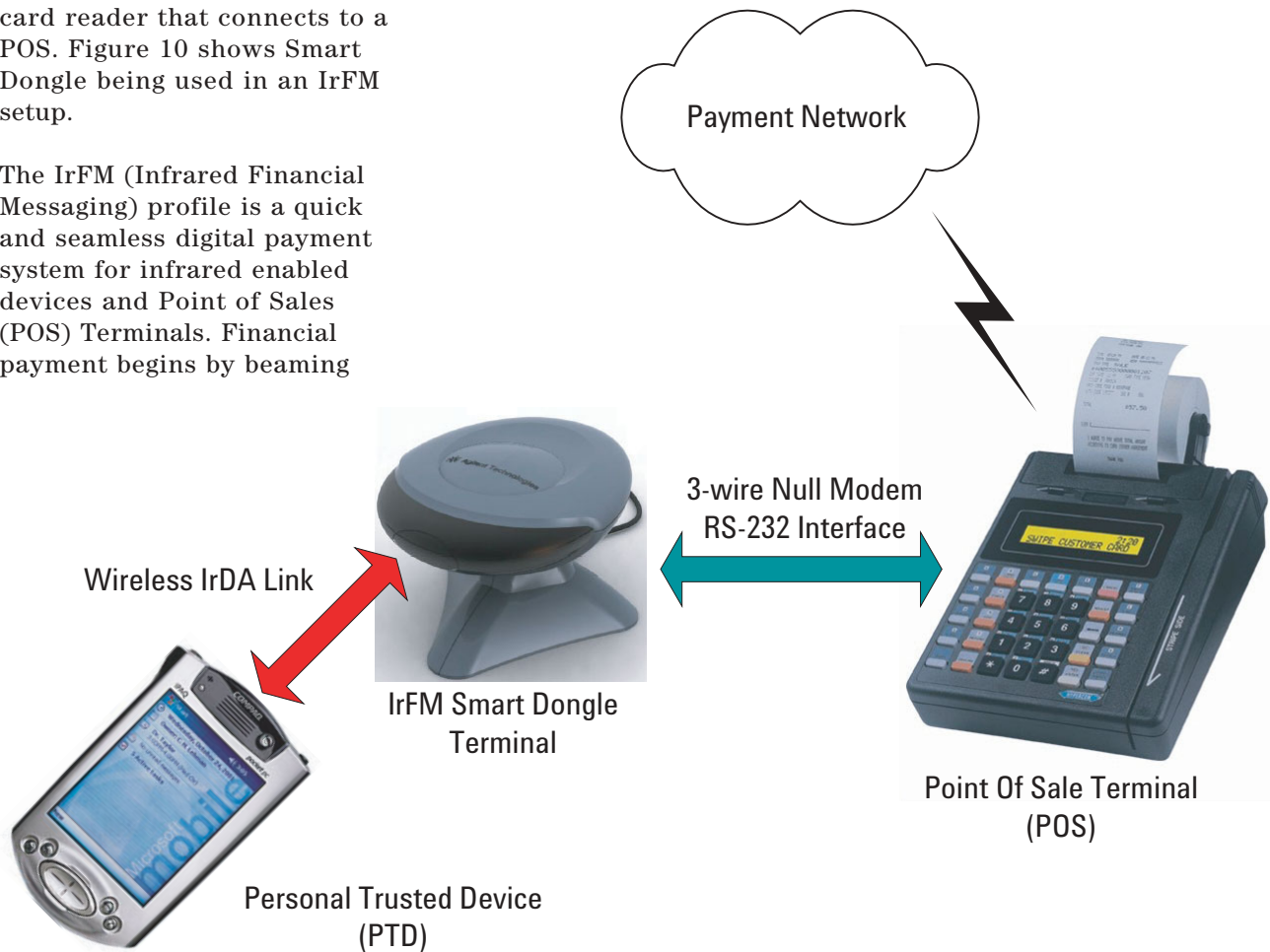

Figure 10. A typical application setup of the IrFM Smart Dongle in proximity payment

Software Architecture for IrFM Application

The IrDA protocol stack is developed in layers, with API service for each layer of the infrared communication protocols. Figure 7 shows an overview of IrFM customized Smart Dongle software architecture. The IrFM software system consists of the following:

- **IrDA Port**

The physical IrDA port provides a continuous, bidirectional communication up to 30 cm with 30degree half angle cone. Communication speed varies between 9600bps to 115.2kbps with the data packet validation by software CRC-16.

- **Physical Driver**

A set of low-level functions are provided to control and configure the hardware such as the HSDL-3208 IrDA Transceiver, 16550 Compatible UART with ENDEC etc.

- **IrDA Base Protocol Layers**

IrDA Base Protocol Layers consists of the following layers:

- **IrLAP**

Provides a reliable device-to-device connection for reliable ordered transfer of data between two IrDA devices. This protocol is a variant derived from the multi-drop HDLC protocol that manage information exchange, connection/disconnection, resolve address conflict, discovery to identify other devices and sniffing for devices to connect to.

- **LM-IAS**

Maintains an information database for the IrDA device to identify itself to other IrDA devices on the services it offers and looks for another compliant IrDA device as well.

- **LM-MUX**

Provides multiple links over a single IrLAP.

- **TinyTP**

TinyTP provides a flow control mechanism, segmentation and reassembly of data packets for each transport connection created.

- **IrSock**

This layer serves as an interface for higher layer application to access the underlying IrDA protocol stack..

- **OBEX**

Provides generic Object Exchange services to the application to support IrOBEX operations such as CONNECT, PUT, GET, SETPATH, ABORT and DISCONNECT. This layer is required for implementing the IrFM Point and Pay Profile.

- **Core IrFM Protocol (CIP)**

Provides the IrFM Services with a set of primitives and corresponding data object that conforms to the CIP specifications, for data to be exchanged between the POS and PTD devices.

- **Applications (IrFM Service)**

This layer provides IrFM services to user application.

IrFM Transaction Flow

Figure 11 illustrates a typical the transaction flow for an IrFM Transaction among the Personal Trusted Device, Smart Dongle and the POS/CAT Terminal.

Sale transaction starts with the POS initiates an IrFM transaction with a customer's PTD through the Smart Dongle by sending the purchasing amount to the Smart Dongle.

The Smart Dongle establish a reliable IR connection, that is capable of resuming a session without the lost of data when the underlying transport layer (i.e. IrLAP Link) is temporary broken. This is accomplished by employing the OBEX Session Protocol.

After a successful OBEX Session has been setup, the Smart Dongle and customer's PTD complete the IrFM

transaction by using a set of Core IrFM Service.

A soft copy of the digital receipt is beamed to the customer's PTD for verification and tracking at the end of IrFM transaction.

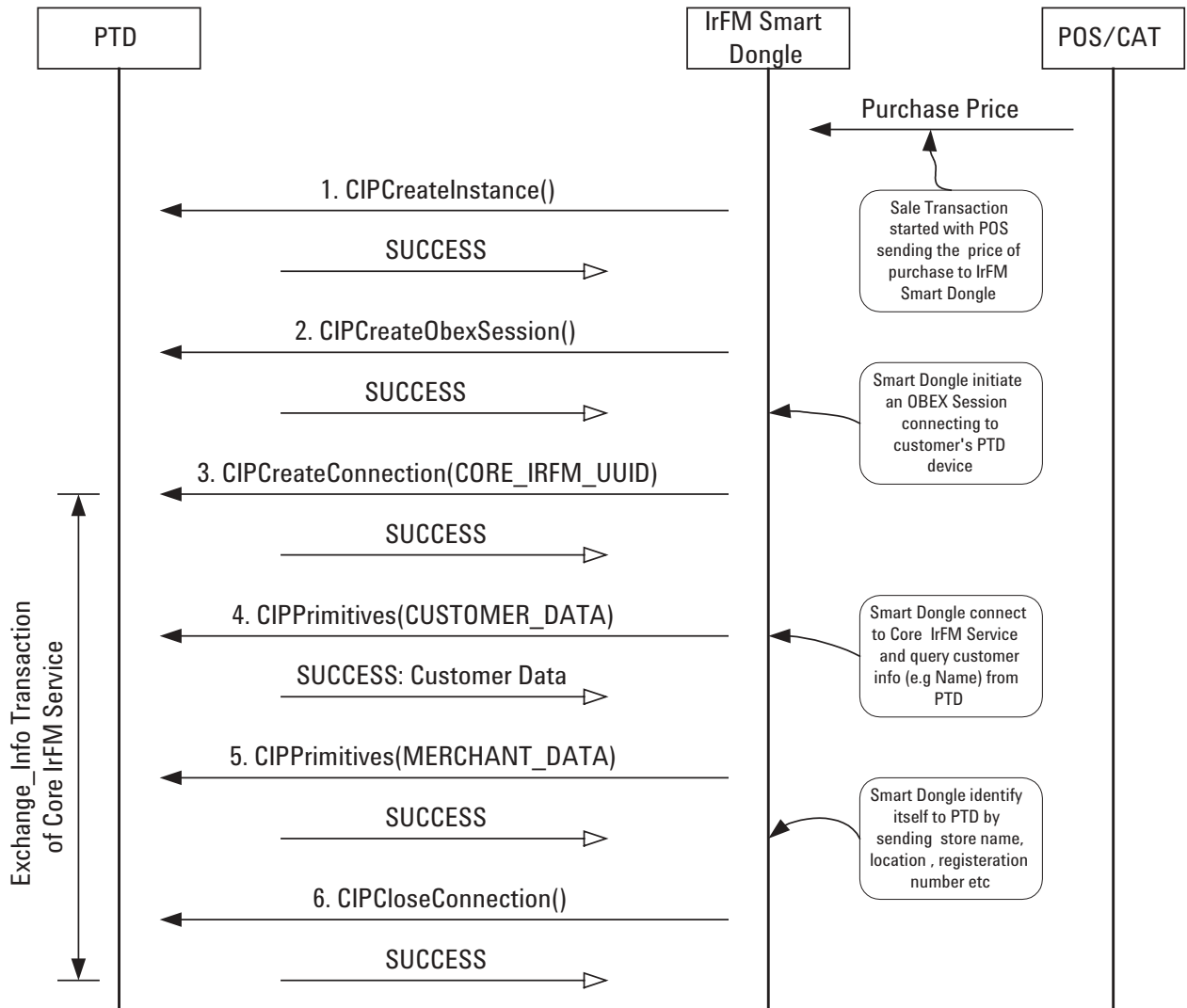

Figure 11. A Typical IrFM Transaction Flow (part 1)

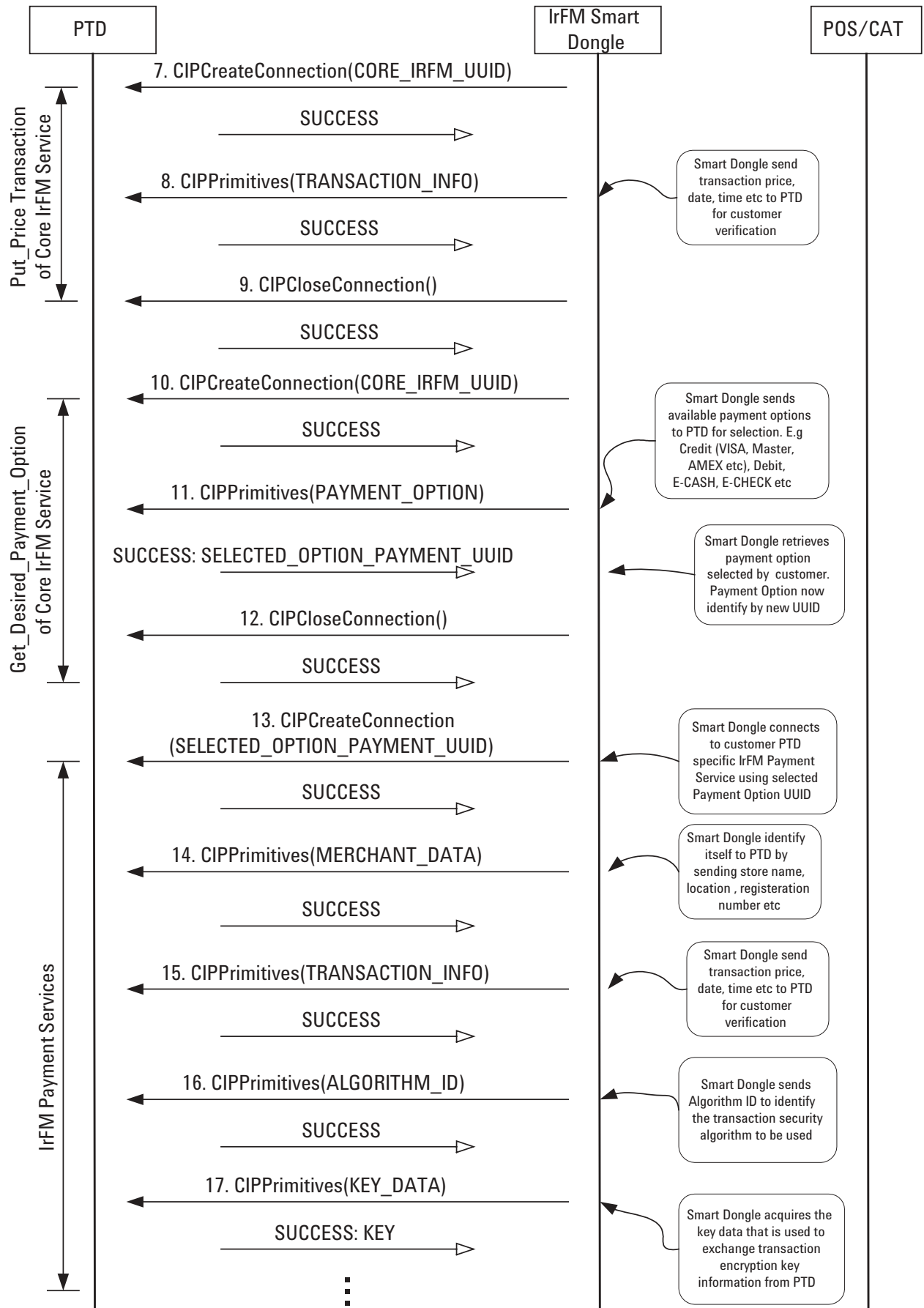
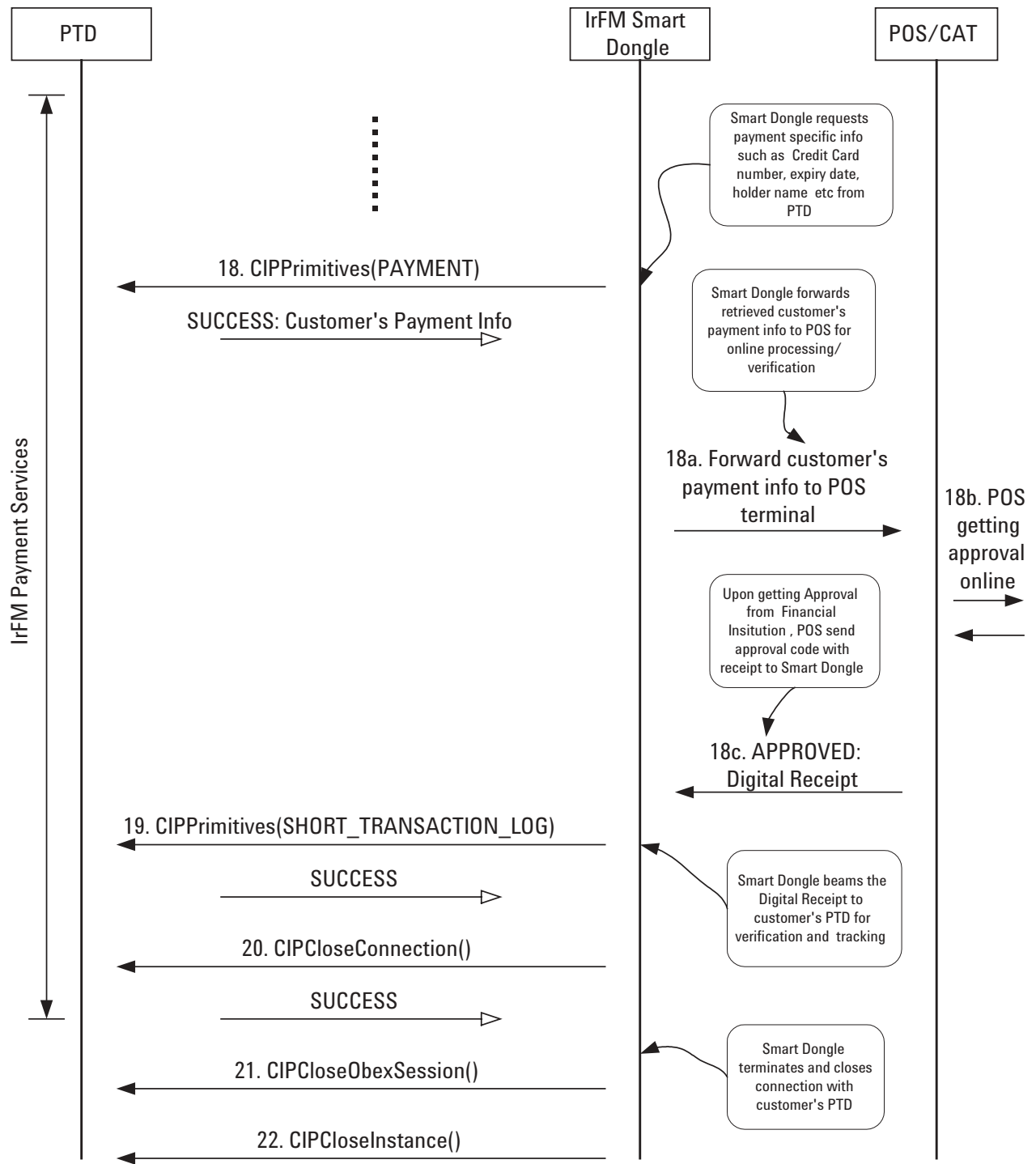

Figure 11. A Typical IrFM Transaction Flow (part 2)



-- Sale Transaction Completed --

Figure 11. A Typical IrFM Transaction Flow (part 3)

**www.agilent.com/
semiconductors**

For product information and a complete list of distributors, please go to our web site.

For technical assistance call:

Americas/Canada: +1 (800) 235-0312
or (408) 654-8675

Europe: +49 (0) 6441 92460

China: 10800 650 0017

Hong Kong: (+65) 6756 2394

India, Australia, New Zealand: (+65) 6755 1939

Japan: (+81 3) 3335-8152(Domestic/International), or 0120-61-1280(Domestic Only)

Korea: (+65) 6755 1989

Singapore, Malaysia, Vietnam, Thailand, Philippines, Indonesia: (+65) 6755 2044

Taiwan: (+65) 6755 1843

Data subject to change.

Copyright © 2004 Agilent Technologies, Inc.

April 6, 2004

5989-0865EN



Agilent Technologies