

SPS-93120FW-CXX0G / SPS-93120BFW-CXX0G (RoHS Compliant)

3.3V / CWDM / 2.125 Gbps Digital Diagnostic SFP LC SINGLE-MODE TRANSCEIVER

FEATURES

- | Hot-Pluggable SFP Footprint LC Optical Transceiver
- | Small Form-Factor Pluggable (SFP) MSA compatible
- | **8 Wavelength (λ): 1470 nm to 1610 nm CWDM DFB LD Transmitter**
- | Compliant with IEEE 802.3z 1000BASE
- | Compliant with Fibre Channel 1X/2X SM-LC-L FC-PI
- | **SFF-8472 Digital Diagnostic Function**
- | APD High Sensitivity Receiver
- | 30 dB Power Budget at Least
- | AC/AC Coupling according to MSA
- | Single +3.3 V Power Supply
- | RoHS Compliant
- | 0 to 70°C Operation: SPS-93120FW-CXX0G
- | -5 to 85°C Operation: SPS-93120BFW-CXX0G
- | Class 1 Laser International Safety Standard IEC 60825 Compliant

DESCRIPTION

The SPS-93120FW-CXX0G series single mode transceivers is small form factor pluggable module for bi-directional serial optical data communications such as Gigabit Ethernet 1000BASE-ZX and Fibre Channel 1Xx/2X SM-LC-L FC-PI. It is with the SFP 20-pin connector to allow hot plug capability. Digital diagnostic functions are available via an I²C. This module is designed for single mode fiber and operates at a nominal wavelength of CWDM wavelength. There are eight center wavelengths available from 1470 nm to 1610 nm, with each step 20 nm. A guaranteed minimum optical link budget of 30 dB is offered. The transmitter section uses a multiple quantum well CWDM DFB laser and is a class 1 laser compliant according to International Safety Standard IEC-60825. The receiver section uses an integrated InGaAs detector preamplifier (IDP) mounted in an optical header and a limiting post-amplifier IC.

APPLICATIONS

- | ATM Switches and Routers
- | SONET / SDH Switch Infrastructure
- | XDSL Applications
- | Metro Edge Switching

LASER SAFETY

This single mode transceiver is a Class 1 laser product. It complies with IEC-60825 and FDA 21 CFR 1040.10 and 1040.11. The transceiver must be operated within the specified temperature and voltage limits. The optical ports of the module shall be terminated with an optical connector or with a dust plug.

ORDER INFORMATION

P/No.	Bit Rate (Gb/s)	FC-PI	Power Budget (dB)	Wavelength (nm)	Package	Temp. (°C)	TX Power (dBm)	RX Sens. (dBm)	RoHS Compliant
SPS-93120FW-CXX0G	2.125/1.063	200/100	> 30	CWDM*	LC SFP with DMI	0 to 70	5 to 0	-30	Yes
SPS-93120BFW-CXX0G	2.125/1.063	200/100	> 30	CWDM*	LC SFP with DMI	-5 to 85	5 to 0	-30	Yes

CWDM* Wavelength (0 to 70°C)

Central Wavelength	Min. (nm)	Typ. (nm)	Max. (nm)	Central Wavelength	Min. (nm)	Typ. (nm)	Max. (nm)
-C470	1464.5	1470	1477.5	-C550	1544.5	1550	1557.5
-C490	1484.5	1490	1497.5	-C570	1564.5	1570	1577.5
-C510	1504.5	1510	1517.5	-C590	1584.5	1590	1597.5
-C530	1524.5	1530	1537.5	-C610	1604.5	1610	1617.5

CWDM*: 8 Wavelengths from 1470 nm to 1610 nm, each step 20 nm.

Absolute Maximum Ratings						
Parameter	Symbol	Min	Max	Units	Notes	
Storage Temperature	T _{stg}	-40	85	°C		
Operating Case Temperature	T _{opr}	0	70	°C	SPS-93120FW-CXX0G	
		-5	85		SPS-93120BFW-CXX0G	
Power Supply Voltage	V _{cc}	-0.5	3.6	V		

Recommended Operating Conditions						
Parameter	Symbol	Min	Typ	Max	Units / Notes	
Power Supply Voltage	V _{cc}	3.13	3.3	3.47	V	
Operating Case Temperature	T _{opr}	0		70	°C / SPS-93120FW-CXX0G	
		-5		85	°C / SPS-93120BFW-CXX0G	
Power Supply Current	I _{CC(TX+RX)}		200	300	mA	
Data Rate		1000	2125		Mb/s	

Transmitter Specifications (0°C < T _{opr} < 70°C, 3.13V < V _{cc} < 3.47V)						
Parameter	Symbol	Min	Typ	Max	Units	Notes
Optical						
Optical Transmit Power	P _o	0	---	5	dBm	1
Output Center Wavelength	λ	λ _c -5.5	λ _c	λ _c +7.5	nm	2
Output Spectrum Width	Δλ	---	---	1	nm	-20 dB Width
Side Mode Suppression Ratio	SMSR	30			dB	
Extinction Ratio	E _R		9	---	dB	
Optical Modulation Amplitude (Peak-to-Peak)	OMA	174			μW	FC-PI Standard
Optical Rise Time	t _r			160	ps	20 % to 80% Values
Optical Fall Time	t _f			160	ps	20 % to 80% Values
Relative Intensity Noise	RIN			-120	dB/Hz	
Dispersion Penalty				2.5	dB	
Electrical						
Data Input Current – Low	I _{IL}	-350			μA	
Data Input Current – High	I _{IH}			350	μA	
Differential Input Voltage	V _{IH} - V _{IL}	0.5		2.4	V	Peak-to-Peak
TX Disable Input Voltage – Low	T _{DIS,L}	0		0.5	V	3
TX Disable Input Voltage – High	T _{DIS,H}	2.0		V _{cc}	V	3
TX Disable Assert Time	T _{ASSERT}			10	μs	
TX Disable Deassert Time	T _{DEASSERT}			1	ms	
TX Fault Output Voltage -- Low	T _{FAULTL}	0		0.5	V	4
TX Fault Output Voltage -- High	T _{FAULTH}	2.0		V _{cc} +0.3	V	4

1. Output power is power coupled into a 9/125 μm single mode fiber.
2. ITU-T G.694.2 CWDM wavelength from 1470 nm to 1610 nm, each step 20 nm.
3. There is an internal 4.7K to 10K ohm pull-up resistor to V_{cc}TX.
4. Open collector compatible, 4.7K to 10K ohm pull-up to V_{cc} (Host Supply Voltage).

Receiver Specifications (0°C < T _{opr} < 70°C, 3.13V < V _{cc} < 3.47V)						
Parameter	Symbol	Min	Typ	Max	Units	Notes
Optical						
Sensitivity @2.125Gb/s @ BER=10 ⁻¹²	SENS (2X)	---	---	-30	dBm	4
Maximum Input Power	P _{in}	-9			dBm	4
Signal Detect -- Asserted	P _a	---		-30	dBm	Transition: low to high
Signal Detect -- Deasserted	P _d	-40	---	---	dBm	Transition: high to low

Signal detect -- Hysteresis		1.0	---		dB	
Wavelength of Operation		1260	---	1620	nm	
Electrical						
Differential Output Voltage	$V_{OH} - V_{OL}$	0.6		2.0	V	
Output LOS Voltage -- Low	V_{OL}	0		0.5	V	5
Output LOS Voltage -- High	V_{OH}	2.0		$V_{cc}+0.3$	V	5

4. Measured at 2^7-1 PRBS at BER $1E-12$.

5. Open collector compatible, 4.7K to 10K ohm pull-up to Vcc (Host Supply Voltage).

CONNECTION DIAGRAM

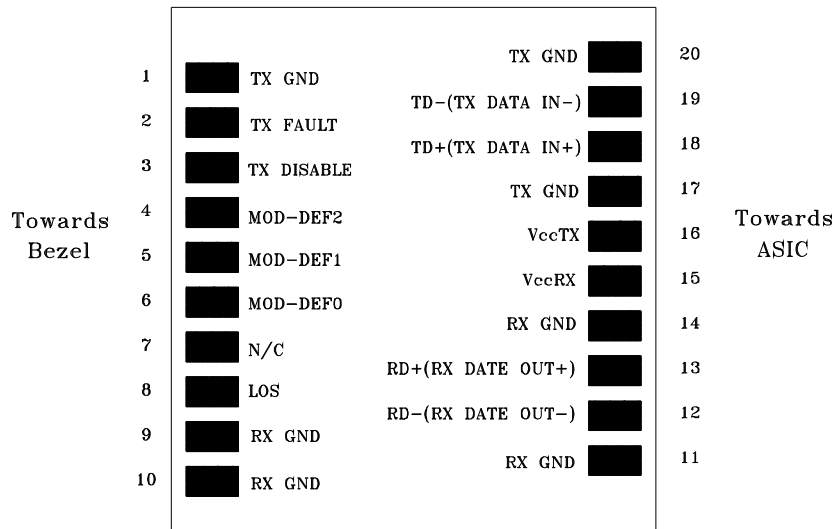

PIN	Signal Name	Description	PIN	Signal Name	Description
1	TX GND	Transmitter Ground	11	RX GND	Receiver Ground
2	TX Fault	Transmitter Fault Indication	12	RX DATA OUT-	Inverse Receiver Data Out
3	TX Disable	Transmitter Disable (Module disables on high or open)	13	RX DATA OUT+	Receiver Data Out
4	MOD-DFE2	Modulation Definition 2 – Two wires serial ID Interface	14	RX GND	Receiver Ground
5	MOD-DEF1	Modulation Definition 1 – Two wires serial ID Interface	15	Vcc RX	Receiver Power – 3.3V±5%
6	MOD-DEF0	Modulation Definition 0 – Ground in Module	16	Vcc TX	Transmitter Power – 3.3V±5%
7	N/C	Not Connected	17	TX GND	Transmitter Ground
8	LOS	Loss of Signal	18	TX DATA IN+	Transmitter Data In
9	RX GND	Receiver Ground	19	TX DATA IN-	Inverse Transmitter Data In
10	RX GND	Receiver Ground	20	TX GND	Transmitter Ground

Module Definition

Module Definition	MOD-DEF2 PIN 4	MOD-DEF1 PIN 5	MOD-DEF0 PIN 6	Interpretation by Host
4	SDA	SCL	LV-TTL Low	Serial module definition protocol

Module Definition 4 specifies a serial definition protocol. For this definition, upon power up, MOD-DEF(1:2) appear as no connector (NC) and MOD-DEF(0) is TTL LOW. When the host system detects this condition, it activates the serial protocol. The protocol uses the 2-wire serial CMOS E²PROM protocol of the ATMEL AT24C01A/02/04 family of components.

RECOMMENDED CIRCUIT SCHEMATIC

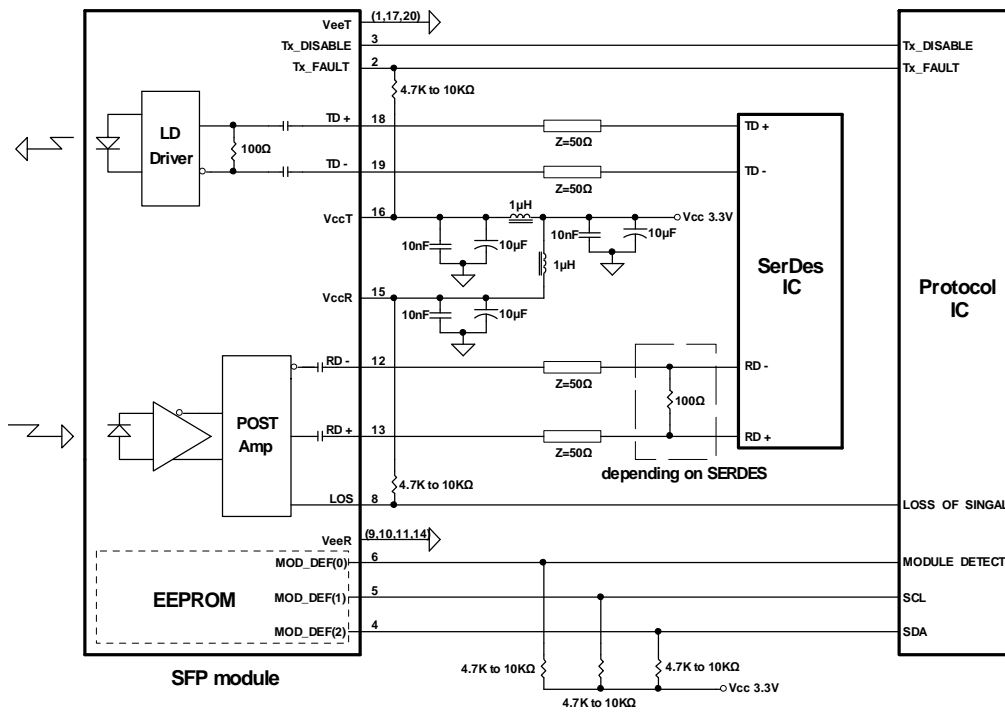

PACKAGE DIAGRAM

Units in mm

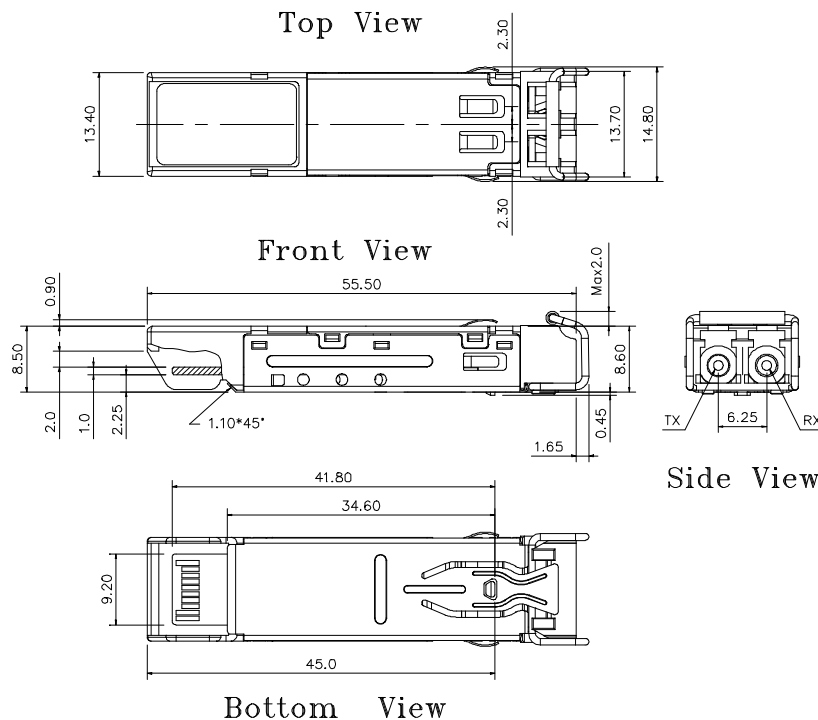

Note: Specifications subject to change without notice.