

To all our customers

Regarding the change of names mentioned in the document, such as Mitsubishi Electric and Mitsubishi XX, to Renesas Technology Corp.

The semiconductor operations of Hitachi and Mitsubishi Electric were transferred to Renesas Technology Corporation on April 1st 2003. These operations include microcomputer, logic, analog and discrete devices, and memory chips other than DRAMs (flash memory, SRAMs etc.) Accordingly, although Mitsubishi Electric, Mitsubishi Electric Corporation, Mitsubishi Semiconductors, and other Mitsubishi brand names are mentioned in the document, these names have in fact all been changed to Renesas Technology Corp. Thank you for your understanding. Except for our corporate trademark, logo and corporate statement, no changes whatsoever have been made to the contents of the document, and these changes do not constitute any alteration to the contents of the document itself.

Note : Mitsubishi Electric will continue the business operations of high frequency & optical devices and power devices.

Renesas Technology Corp.
Customer Support Dept.
April 1, 2003

PRELIMINARY

Notice ; This is not a final specification.
some parametric limits are subject to change.

MITSUBISHI SOUND PROCESSORS

M62465FP

Dolby Pro Logic Surround

DESCRIPTION

The M62465FP is a single chip LSI supporting the Dolby Prologic surround. This LSI contains all functions necessary for Dolby Pro Logic surround. In addition, it has Digital Space Surround functions (Disco, Hall, Live mode etc.) and echo function for karaoke.
Note: Use of this LSI requires the license of Dolby Laboratories Licensing Corporation

Dolby and the double-D symbol are trademarks of Dolby Laboratories Licensing Corporation, San Francisco, CA94103-4813, USA.
This device available only to licensees of Dolby Lab.
Licensing and application information may be obtained from Dolby Lab.

Features (Mode)

- Upper compatible for M62460FP and less external parts than M62460FP.
- Includes all functions requires for Dolby Pro Logic Surround.
 - Adaptive Matrix.
 - Noise Sequencer by digital noise source and switched capacitor filter.
 - Center Mode Control (Wide/Normal/PHANTOM/OFF).
 - Modified Dolby B Type Noise Reduction.
 - 4ch/3ch Stereo Selectable.
 - Digital Delay: 15.4, 20, 28.6ms for Dolby Pro Logic Surround.
- C/Sch Trimmer: 0 to -31dB/1dB Step.
- Digital Space Surround Mode: Disco/Hall/Live mode and 5 delay time positions.
- Digital Echo function for KARAOKE: (Short echo) Delay time=147.5ms, (Long echo) Delay time=196.6ms.
- BY-PASS Mode: Input signal through output.

Outline



Outline 80P6N
0.8mm pitch QFP
(20.0mm×14.0mm×2.8mm)

System Configuration

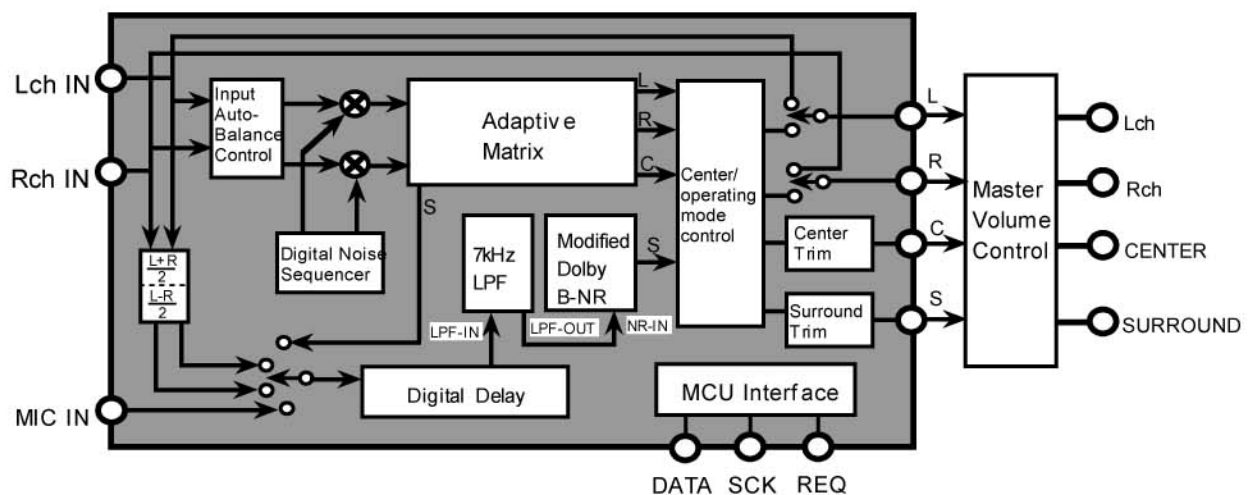

PRELIMINARY

Notice ; This is not a final specification.
some parametric limits are subject to change.

MITSUBISHI SOUND PROCESSORS

M62465FP

Dolby Pro Logic Surround

PIN CONFIGURATION

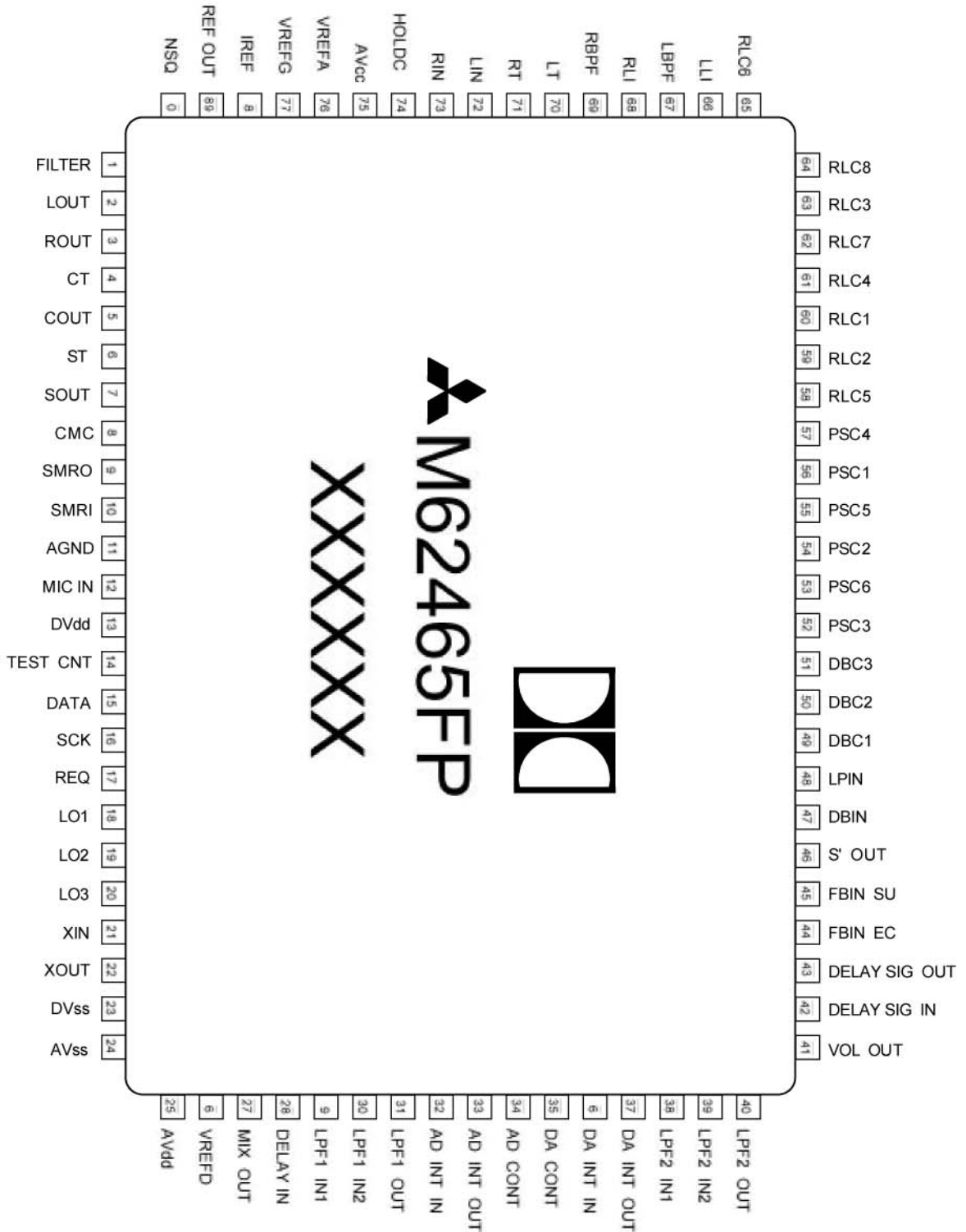

(Note) The function of pin No. 1,79,80 is different from that of M62460FP.

PRELIMINARY

Notice ; This is not a final specification.
some parametric limits are subject to change.

MITSUBISHI SOUND PROCESSORS

M62465FP

Dolby Pro Logic Surround

BLOCK DIAGRAM

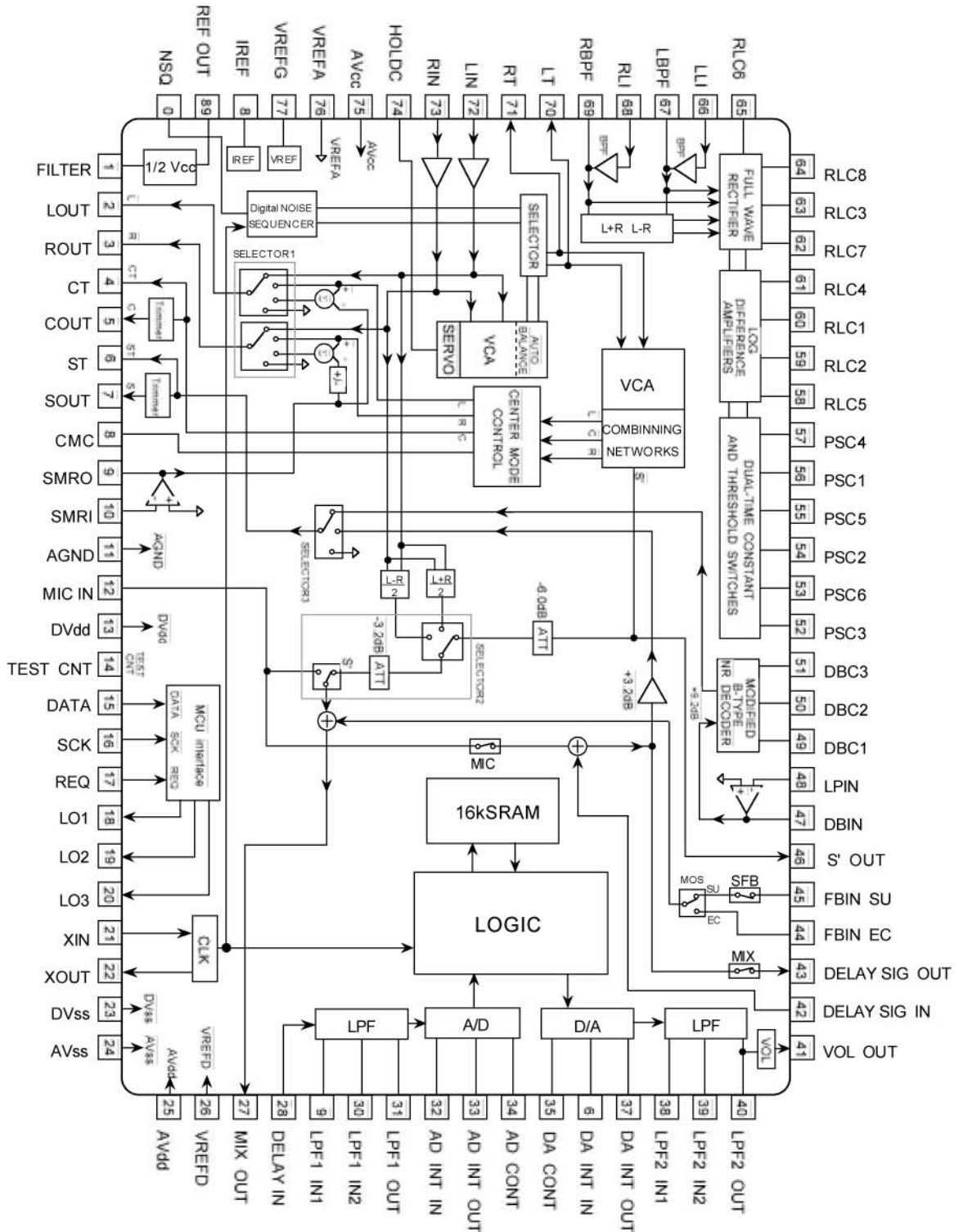

(Note) The function of pin No. 1,79,80 is different from that of M62460FP.

PRELIMINARY

Notice ; This is not a final specification.
some parametric limits are subject to change.

MITSUBISHI SOUND PROCESSORS

M62465FP

Dolby Pro Logic Surround

Discription of pin

No.	Symbol	Funtion	Voltage	Discription of pin	Equivalent circuit
②	LOUT	Lch output	4V	Direct output R-/ L-channel when the operation mode is BY-PASS. When the mode is 4channel, they output Dolby prologic R-/ L-channel signals.	
③	ROUT	Rch output			
④	CT	Cch output	4V	No output any signals when the operation mode is center mode is OFF or set to PHANTOM. COUT is output from C.Trimmer.	
⑤	COUT	Cch output			
⑥	ST	Sch output	4V	This pin output surrund signals.Output is selected from BNRout,Dout No output signal when the operation mode is 3STEREO/MUTE. SOUT is output from S.Trimmer.	
⑦	SOUT	Sch output			
⑨	SMRO	amplifier output	4V	This is a amplifier to control mixed level of surrund output with external resistance.	
⑩	SMRI	amplifier input			

PRELIMINARY

Notice ; This is not a final specification.
some parametric limits are subject to change.

MITSUBISHI SOUND PROCESSORS

M62465FP

Dolby Pro Logic Surround

No.	Symbol	Funtion	Voltage	Discription of pin	Equivalent circuit
⑫	MIC IN	MIC input	4V	Microphone input with ECHO MODE	
⑭	TEST CNT	TEST control	0	Fixed to GND	
⑮	DATA	serial data "DATA" input	—	input via serial data from MCU.	
⑯	SCK	serial data "SCK" input	0		
⑰	REQ	serial data "REQ" input			
⑱	LO1	port output	—	Open collector output pin (NPN Tr)	
⑲	LO2				
⑳	LO3				
㉑	XIN	Osillator input	—	connect 4 - MHz ceramic resonator	
㉒	XOUT	Osillator output			
㉔	VREFD	reference output	2.5V	1/2 Vcc output. Connect a filter capacitor.	

PRELIMINARY

Notice ; This is not a final specification.
some parametric limits are subject to change.

MITSUBISHI SOUND PROCESSORS

M62465FP

Dolby Pro Logic Surround

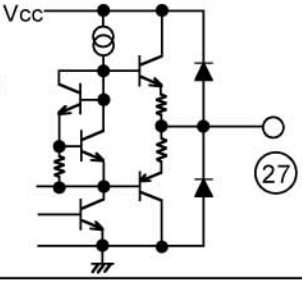
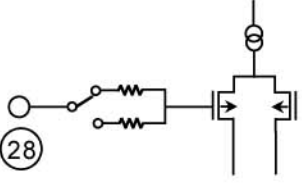
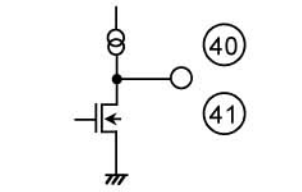
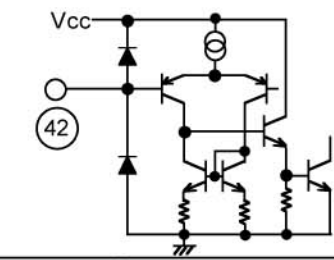
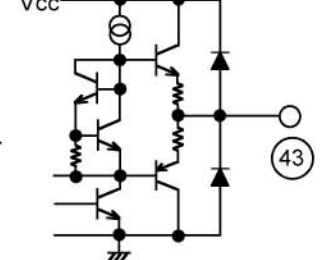
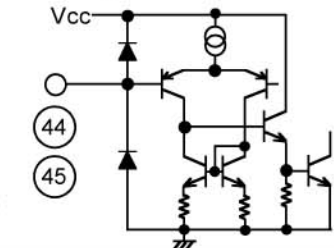
No.	Symbol	Funtion	Voltage	Discription of pin	Equivalent circuit
②⑦	MIX OUT	S',L+R,L-R and MIC output	4V	Signal output precedent to delay generator. that is S',L+R,L-R and MIC output.	
②⑧	DELAY IN	delay input	2.5V	This is s delay input. Please input by AC cupping.	
④①	LPF2 OUT	delay signal output	2.5V	delay signal output	
④①	VOL OUT	output of a delay volum		This is output of a delay volum that possible to control +3dB to -∞.	
④②	DELAYSIG IN		4V	Delay signal input to a mixing amplifier	
④③	DELAYSIG OUT	input from mixing amplifier	4V	Delay signal output from a mixing amplifier	
④④	FBIN EC	Feedback signal input	4V	Feedback signal input with ECHO MODE	
④⑤	FBIN SU			Feedback signal input with SURROUND MODE	

PRELIMINARY

Notice ; This is not a final specification.
some parametric limits are subject to change.

MITSUBISHI SOUND PROCESSORS

M62465FP

Dolby Pro Logic Surround

No.	Symbol	Funtion	Voltage	Discription of pin	Equivalent circuit
(46)	S'OUT	Sch output	4V	Sorrund channel output precedent to delay generator. Always outputs signals,irrespective of the operation mode (2-/3-/4-channel)	
(47)	DBIN	LPF output	4V	This amplifier compornent 7KHz-LPF with external resistances and capacitors. LPF output is conected to input of Modifide BNR.	
(48)	LPIN	Negative input of LPF			
(72)	LIN	Lch input	4V	Input of Lch and Rch that is non-inverted input type. Please pul-up to VREF by external resistances for DC bias.	
(73)	RIN	Rch input			
(70)	LT	Autobalance Lch output	4V	Autobalance output.	
(71)	RT	Autobalance Rch output			

PRELIMINARY

Notice ; This is not a final specification.
some parametric limits are subject to change.

MITSUBISHI SOUND PROCESSORS

M62465FP

Dolby Pro Logic Surround

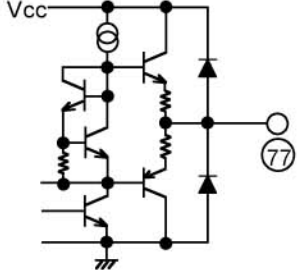
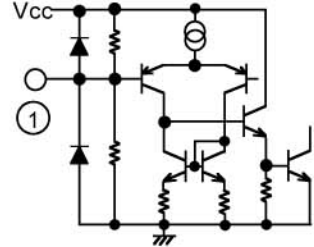
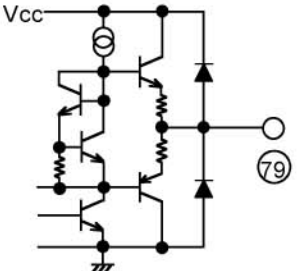
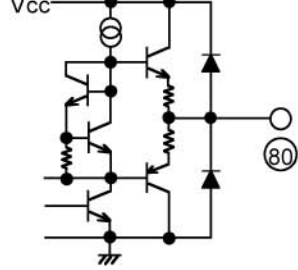
No.	Symbol	Funtion	Voltage	Discription of pin	Equivalent circuit
76	VREFA	reference voltage input	—	It is a reference voltage input terminal to each circuit inside the IC.	
77	VREFG	reference voltage output	4V	Reference voltage output. Voltage is the fixed at 4V.	
1	FILTER New future of M62465FP	1/2Vcc Auxiliary 1/2Vcc reference generator.	1/2 Vcc	The terminal which make a 1/2Vcc voltage by the resistance. When it is used, a filter capacitor is connected.	
79	REF OUT New future of M62465FP	1/2Vcc output	1/2 Vcc	1/2Vcc voltage output. It is used to change reference voltage except 4V.	
80	NSQ New future of M62465FP	Noise sequencer monitor	4V	Noise sequencer monitor output. It is only for test.	

PRELIMINARY

Notice ; This is not a final specification.
some parametric limits are subject to change.

MITSUBISHI SOUND PROCESSORS

M62465FP

Dolby Pro Logic Surround

ABSOLUTE MAXIMUM RATINGS

Symbol	Parameter	Test conditions	Limits	Unit
V _{CC}	Supply voltage		10.5	V
V _{DD}			6.5	V
P _d	Power dissipation	standard board	1.37	W
K _θ	Thermal derating	T _a ≥ 25°C	13.7	mW/°C
T _{opr}	Operating temperature		-20 to +75	°C
T _{stg}	Storage temperature		-40 to +125	°C

TERMAL DERATING

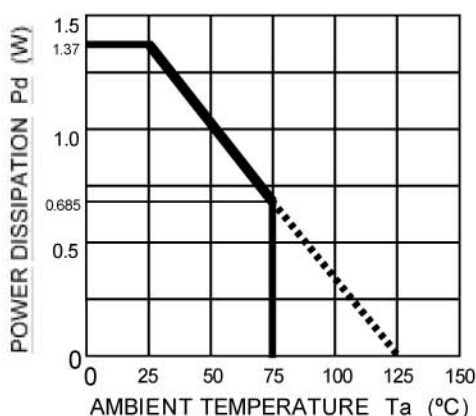

* Standard board

- board size 70mm×70mm
- board thickness 1.6mm
- board material glass epoxy
- copper pattern 18□m
- copper thickness 0.25mm(width)
- copper size 30mm(length / lead)

RECOMMENDED OPERATING CONDITION

Symbol	Parameter	Conditions	Ratings			Unit
			Min	Typ	Max	
V _{CC}	Analog supply voltage		8.0	9.0	10.0	V
V _{DD}	Digital supply voltage		4.5	5.0	5.5	V
f _{ck}	OSC clock			4		MHz

PRELIMINARY

Notice ; This is not a final specification.
some parametric limits are subject to change.

MITSUBISHI SOUND PROCESSORS

M62465FP

Dolby Pro Logic Surround

ELECTRICAL CHARACTERISTICS (DECODER)

V_{CC}=9V, V_{DD}=5V 0dB Reference=300mVrms/1KHz at C-OUT unless otherwise noted.(Cch Trimmer=0dB)

Symbol	Parameter	Conditions	Limits			Unit
			Min	Typ	Max	
Overall						
I _{CC}	Circuit Current	Quiescent	—	25	50	mA
I _{DD}	Circuit Current	Quiescent	—	25	50	mA
V _{ref}	Reference Voltage	Quiescent	3.5	4.0	4.5	V
Input Auto Balance						
CPR	Capture Range		—	±5	—	dB
CER	Error Correction		—	±4	—	dB
Adaptive Matrix						
ΔV _{OL}	Output Level Accuracy relative to C ch	L, R, S'ch out	-0.5	0	0.5	dB
MR	Matrix Rejection relative	L, R, C, S'ch out	25	40	—	dB
HRAM	Headroom	L, R, C, S' out	15	17	—	dB
THDAM	Total Harmonic Distortion	L, R, C, S'ch out 4ch mode	—	0.05	0.2	%
		L, Rch out 2ch mode	—	0.002	0.05	
SNAM	Signal to Noise Ratio	R _g =0Ω, weighted CCIR/AMR 4ch mode	75	80	—	dB
		L, Rch out 2ch mode	95	100	—	
NopAM	Peak Noise	measurement time 4ch mode	—	—	±0.3	mV _{0-p}
		=40msec 2ch mode	—	—	±0.3	
Noise Sequencer (0dB Reference is input at NR-IN when adjust to 0dB (300mVrms/100Hz) at S out.						
V _{no}	Output Noise Level		-15	-12.5	-10	dB
ΔV _{no}	Output Level Accuracy relative to C ch	L, R, S'ch out	-0.5	0	0.5	dB
V _{nop}	Output Noise peak	measurement time=6sec	—	—	±550	mV _{0-p}
Modified B type Noise Reduction						
VGNR	Voltage Gain	V _{in} =0dBd, f=100Hz	—	9.2	—	dB
DEC1	Decode Responce 1	V _{in} =0dBd, f=1.0kHz	-1.6	-0.1	1.4	dB
DEC2	Decode Responce 2	V _{in} =-15dBd, f=1.4kHz	-3.0	-1.5	0	
DEC3	Decode Responce 3	V _{in} =-20dBd, f=1.4kHz	-4.9	-3.4	-1.9	
DEC4	Decode Responce 4	V _{in} =-40dBd, f=5.0kHz	-6.8	-5.3	-3.8	
THDNR	Total Harmonic Distortion	V _{in} =0dBd, f=1kHz	—	0.0	0.3	%
HRNR	Headroom	THD=1%	15	717	—	dB
SNNR	Signal to Noise Ratio	R _g =0Ω, weighted CCIR/AMR	73	78	—	dB
NoPNR	Peak Noise	measurement time=40msec	—	—	±0.3	mV _{0-p}
C,S ch Trimmer						
ATT-12dB	attenuation level:-12dB	Digital Input=-12	-14	-12	-10	dB
ATT _{max}	Maximum attenuation	Digital Input=-31	-37	-31	-25	dB
TS	Trimmer step		0.6	1.0	1.4	dB
Surround (L+R,L-R) <MIXOUT>						
THDSU	Total Harmonic Distortion	V _{in} =0dBd, f=1kHz	—	0.05	0.2	%
SNSU	Signal to Noise Ratio	R _g =0Ω, weighted CCIR/AMR	85	90	—	dB

PRELIMINARY

Notice ; This is not a final specification.
some parametric limits are subject to change.

MITSUBISHI SOUND PROCESSORS

M62465FP

Dolby Pro Logic Surround

ELECTRICAL CHARACTERISTICS (DIGITAL DELAY)

($T_a=25^{\circ}\text{C}$, $V_{cc}=9\text{V}$, $V_{DD}=5\text{V}$, $V_{in}=200\text{mV}_{rms}$, $f_{ck}=4\text{MHz}$ unless otherwise noted)

Symbol	Parameter	Conditions	Limits			Unit	
			Min	Typ	Max		
Digital Delay							
Td	Delay time	See Delay time control (15/24) for delay time setting.	12.4	15.4	18.4	ms	
			17.0	20.0	23.0		
			25.6	28.6	31.6		
			38.0	41.0	44.0		
			46.2	49.2	52.2		
			137.5	147.5	157.5		
			186.6	196.6	206.6		
Gv	Input-output gain		-3.0	0	3.0	dB	
THD	Output distortion	30kHz LPF	Td=15.4ms	—	0.3	0.6	%
			Td=20.0ms	—	0.3	0.6	
			Td=28.6ms	—	0.5	1.0	
			Td=41.0ms	—	0.6	1.2	
			Td=49.2ms	—	0.7	1.4	
			Td=147.5ms	—	1.5	3.0	
			Td=196.6ms	—	2.0	4.0	
Vomax	Maximum output voltage	30kHz LPF, THD=10%	0.7	1.0	—	Vrms	
No	Output noise voltage	Rg=620Ω, Vi=0mVrms, IHF-A	Td=15.4ms	—	-92	-80	dBv
			Td=20.0ms	—	-92	-80	
			Td=28.6ms	—	-92	-80	
			Td=41.0ms	—	-90	-75	
			Td=49.2ms	—	-90	-75	
			Td=147.5ms	—	-82	-67	
			Td=196.6ms	—	-77	-62	
Delay Volume (VOL OUT)							
Gv	Input-output gain	Volume max	0	3	6	dB	
ATTmax	Maximum attenuation	Delay off mode, Volume min, IHF-A	—	-70	-60	dB	

PRELIMINARY

Notice ; This is not a final specification.
some parametric limits are subject to change.

MITSUBISHI SOUND PROCESSORS

M62465FP

Dolby Pro Logic Surround

TEST CIRCUIT

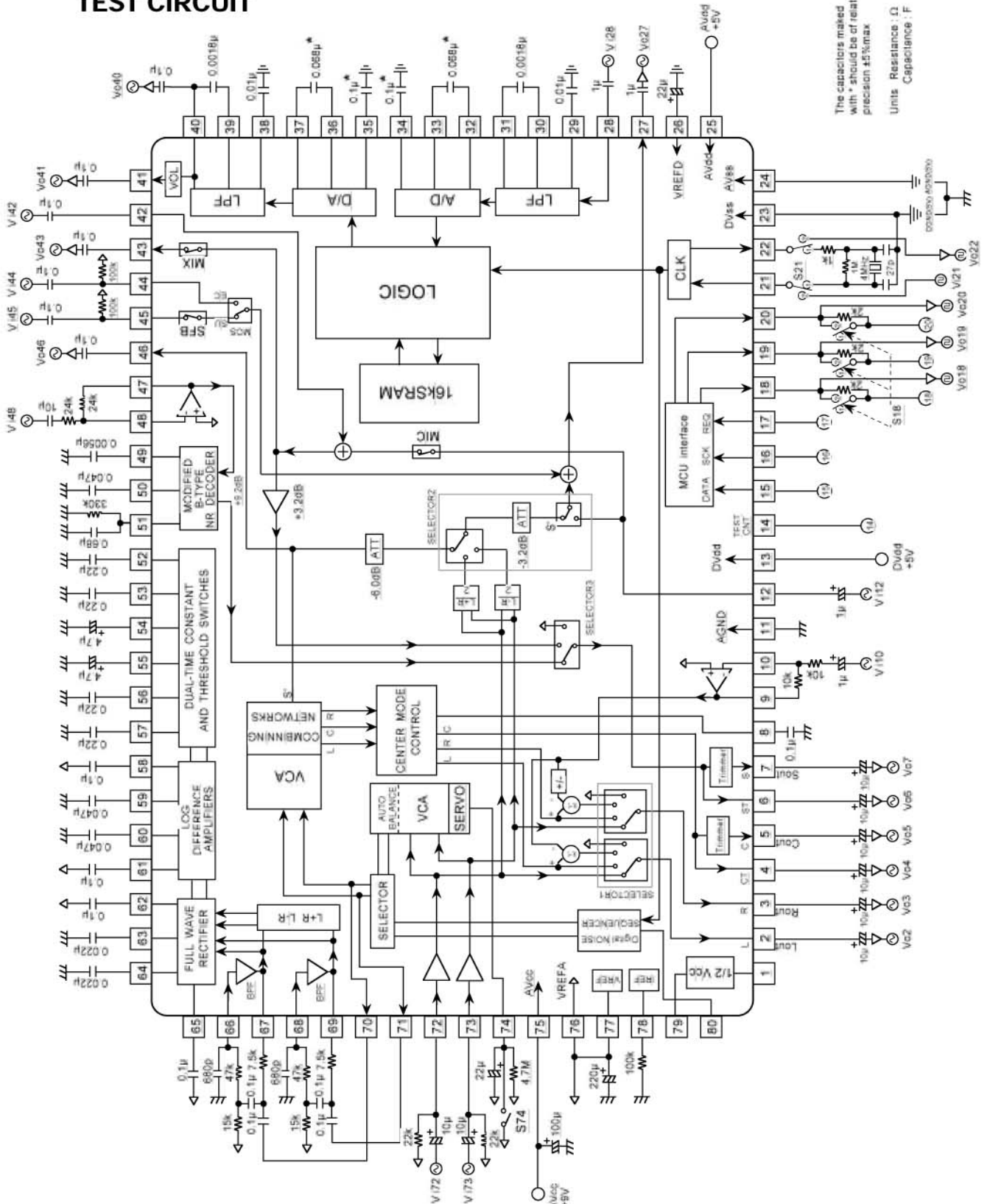

PRELIMINARY

Notice ; This is not a final specification.
some parametric limits are subject to change.

MITSUBISHI SOUND PROCESSORS

M62465FP

Dolby Pro Logic Surround

DIGITAL CONTROL SPECIFICATIONS

(1)DATA TIMING

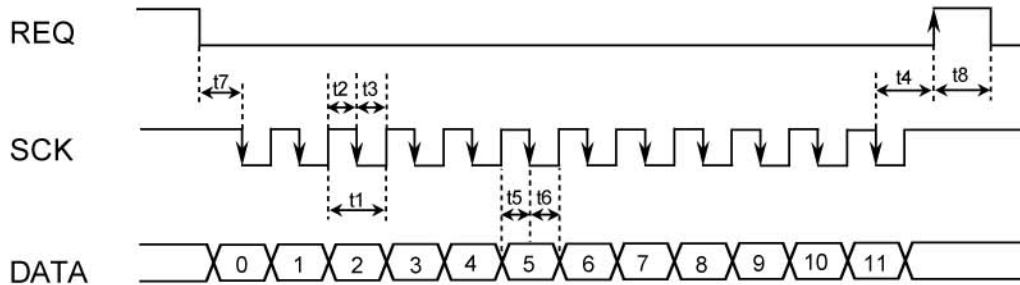

(note1) SCK is disable when REQ is high
(Note2)REQ must turn to high after SCK pulse turn to high.

Symbol	Name	Min	Typ	Max	Unit
t1	SCK clock duration	2	—	—	□s
t2	SCK "H" pulse width	0.8	—	—	□s
t3	SCK "L" pulse width	0.8	—	—	□s
t4	REQ hold time	1.6	—	—	□s
t5	DATA setup time	0.8	—	—	□s
t6	DATA hold time	0.8	—	—	□s
t7	SCK setup time	0.8	—	—	□s
t8	REQ "H" pulse width	1.6	—	—	□s

(2)DATA FORMAT

Serial Data Format											
DATA										ADDRESS	
BIT 0	BIT 1	BIT 2	BIT 3	BIT 4	BIT 5	BIT 6	BIT 7	BIT 8	BIT 9	BIT 10	BIT 11
ADD/SUB	NOISE SEQ			SELECTOR1		CENTER MODE			No use	0	0
SELECTOR2		SELECTOR3		MIX	LO1	LO2	LO3	No use		0	1
Cch. TRIMMER					Sch. TRIMMER					1	0
S1	S2	S3	V1	V2	V3	V4	SFB	MOS	MIC	1	1

PRELIMINARY

Notice ; This is not a final specification.
some parametric limits are subject to change.

MITSUBISHI SOUND PROCESSORS

M62465FP

Dolby Pro Logic Surround

(3) DECODER

◆ ADDRESS(BIT10,11)=0,0

ADD/SUB		NOISE SEQ					SELECTOR1			CENTER MODE		
mode	BIT0	mode	BIT1	mode	BIT2	BIT3	mode	BIT4	BIT5	mode	BIT6	BIT7
ADD	0	OFF	0	L	0	0	PRO LOGIC	0	0	WIDE	0	0
SUB	1	ON	1	C	0	1	BY-PASS	0	1	NORMAL	0	1
				R	1	0	OTHER SUR	1	0	PHANTOM	1	0
				S	1	1	L/R MUTE	1	1	OFF	1	1

◆ ADDRESS(BIT10,11)=0,1

SELECTOR2			SELECTOR3			DELAY MIX SWITCH		
mode	BIT0	BIT1	mode	BIT2	BIT3	BIT4(MIX)	DMIXSW	Remarks
S'	0	0	BNR OUT	0	0	0	OFF	Mixing OFF
L+R	0	1	D OUT	0	1	1	ON	Mixing ON
L-R	1	0	3STEREO/MUTE	1	0			
MIC	1	1		1	1			

LO(LOGIC DATA OUT) Open Collector			
mode	BIT5 (LO1)	BIT6 (LO2)	BIT7 (LO3)
OUTPUT DATA "L"	0	0	0
OUTPUT DATA "H"	1	1	1

• ADDRESS(BIT10,11)=1,0

Cch. TRIMMER						Sch. TRIMMER					
DATA	BIT0	BIT1	BIT2	BIT3	BIT4	DATA	BIT5	BIT6	BIT7	BIT8	BIT9
0	±0dB	±0dB	±0dB	±0dB	±0dB	0	±0dB	±0dB	±0dB	±0dB	±0dB
1	-1dB	-2dB	-4dB	-8dB	-16dB	1	-1dB	-2dB	-4dB	-8dB	-16dB

Volume code

C(S)ch. TRIMMER											
ATT(dB)	BIT0(5)	BIT1(6)	BIT2(7)	BIT3(8)	BIT4(9)	ATT(dB)	BIT0(5)	BIT1(6)	BIT2(7)	BIT3(8)	BIT4(9)
±0	0	0	0	0	0	-16	0	0	0	0	1
-1	1	0	0	0	0	-17	1	0	0	0	1
-2	0	1	0	0	0	-18	0	1	0	0	1
-3	1	1	0	0	0	-19	1	1	0	0	1
-4	0	0	1	0	0	-20	0	0	1	0	1
-5	1	0	1	0	0	-21	1	0	1	0	1
-6	0	1	1	0	0	-22	0	1	1	0	1
-7	1	1	1	0	0	-23	1	1	1	0	1
-8	0	0	0	1	0	-24	0	0	0	1	1
-9	1	0	0	1	0	-25	1	0	0	1	1
-10	0	1	0	1	0	-26	0	1	0	1	1
-11	1	1	0	1	0	-27	1	1	0	1	1
-12	0	0	1	1	0	-28	0	0	1	1	1
-13	1	0	1	1	0	-29	1	0	1	1	1
-14	0	1	1	1	0	-30	0	1	1	1	1
-15	1	1	1	1	0	-31	1	1	1	1	1

PRELIMINARY

Notice ; This is not a final specification.
some parametric limits are subject to change.

MITSUBISHI SOUND PROCESSORS

M62465FP

Dolby Pro Logic Surround

(4)DELAY

ADDRESS(BIT10,11)=1,1

DELAY TIME CONTROL				
BIT0 (S1)	BIT1 (S2)	BIT2 (S3)	DELAY TIME (Sampling frequency)	Delay LPF (Cut-off frequency)
0	0	0	15.4 ms (1MHz)	7.0kHz
0	0	1	20.0 ms (667kHz)	
0	1	0	28.6 ms (500kHz)	
0	1	1	41.0 ms (400kHz)	
1	0	0	49.2 ms (333kHz)	
1	0	1	147.5ms (111.1kHz)	3.0kHz
1	1	0	196.6ms (83.3kHz)	
1	1	1	Delay off mode (clock off)	

VOLUME CONTROL				
BIT3 (V1)	BIT4 (V2)	BIT5 (V3)	BIT6 (V4)	VOL attenuation
1	1	1	1	+3dB
1	1	1	0	0dB
1	1	0	1	-2dB
1	1	0	0	-3dB
1	0	1	1	-4dB
1	0	1	0	-6dB
1	0	0	1	-8dB
1	0	0	0	-9dB
0	1	1	1	-10dB
0	1	1	0	-12dB
0	1	0	1	-15dB
0	1	0	0	-∞
0	0	1	1	-∞
0	0	1	0	-∞
0	0	0	1	-∞
0	0	0	0	-∞

FEEDBACK SWITCH		
BIT7(SFB)	SFB SW	Remarks
0	OFF	Feedback OFF
1	ON	Feedback ON

(In surround mode only)

MODE SELECTOR	
BIT8(MOS)	MODESEL
0	SU line
1	EC line

MICROPHONE MIXING SWITCH		
BIT9(MIC)	MICMIXSW	Remarks
0	OFF	Mic mixing OFF
1	ON	Mic mixing ON

(Note1)Settings in power up

When power is turned on, data is setting in under table by power on reset circuit.

DECODER		DELAY	
Mode	Settings	Mode	Settings
ADD/SUB	ADD	DELAY TIME CONTROL	20.0ms
NOISE SEQ	OFF	VOLUME CONTROL	-∞
SELECTOR1	PRO LOGIC	FEEDBACK SWITCH	OFF
CENTER MODE	WIDE	MODE SELECTOR	SU line
SELECTOR2	S'	DELAY MIX SWITCH	OFF
SELECTOR3	BNR OUT	MICROPHONE MIXING SWITCH	OFF
LQ(LOGIC OUT)	"L"		
Cch.TRIMMER	0dB, ATT(-)		
Sch.TRIMMER	0dB, ATT(-)		

(Note2)

The digital the noise sequencer stop when the clock is off.

PRELIMINARY

Notice ; This is not a final specification.
some parametric limits are subject to change.

MITSUBISHI SOUND PROCESSORS

M62465FP

Dolby Pro Logic Surround

FUNCTION MODE (EXAMPLE)

MODE	SUB-MODE	DIGITAL DELAY	VOLUME LEVEL			SWITCH CONDITION						DIGITAL DELAY INPUT	NOTE		
			Cch Trimmer	Sch Trimmer	Delay VOL	SELECTOR	CENTER MODE	ADD/SUB MIX SW	MODE	FEEDBACK	MIC MIX				
DOLBY PRO LOGIC	WIDE	$t_d=15.4ms,$ $20.0ms,$ $28.6ms$	0 to -31dB	0 to -31dB	VOL OFF (0dB)	1	2	3	WIDE	OFF	SU	OFF	OFF	S'	Feedback level can be changed by output port control(see block diagram)
	NORMAL		1dB/step	1dB/step					NORMAL	OFF					
	PHANTOM								PHANTOM						
DIGITAL SPACE SURROUND	DISCO	$t_d=20ms$	*Pro Logic decoder function is alive. For example C/S trimmer can be available.	VOL.ATT +3dB 0dB -2dB -3dB -4dB -6dB -8dB -9dB -10dB -12dB -15dB -∞	OTHER SUR L-R L+R S' L+R L-R	SUB ADD ADD / SUB SUB	OFF OFF ON / OFF	SU SU	ON OFF ON / OFF	OFF OFF ON / OFF	(L-R) 2 (L+R) 2	(L-R) 2 (L+R) 2	Feedback level can be changed by output port control(see block diagram)		
	Hall	$t_d=49.2ms$													
	LIVE	$t_d=28.6ms$													
KARAOKE/ECHO	Option	5step delay time (BW=7kHz, fck=4MHz)	*Delay time can be set to 5position(15.4, 20.0,28.6,41.0 49.2mSec).	VOL.ATT +3dB 0dB -2dB -3dB -4dB -6dB -8dB -9dB -10dB -12dB -15dB -∞	BY PASS MIC 3STEREO DOUT	ADD ADD / SUB SUB	ON OFF ON / OFF	EC EC	OFF OFF ON / OFF	ON OFF ON / OFF	MIC MIC	MIC MIC	Feedback level can be changed by output port control(see block diagram)		
	SHORT ECHO	$t_d=147.5ms$													
	LONG ECHO	$t_d=196.6ms$													
BY-PASS	BY-PASS	$t_d=20.0ms$	-31dB	-∞	BY PASS	ADD	OFF	SU	OFF	OFF	S'	S'	Feedback level can be changed by output port control(see block diagram)		

PRELIMINARY

Notice ; This is not a final specification.
some parametric limits are subject to change.

MITSUBISHI SOUND PROCESSORS

M62465FP

Dolby Pro Logic Surround

FUNCTION

Block Diagram

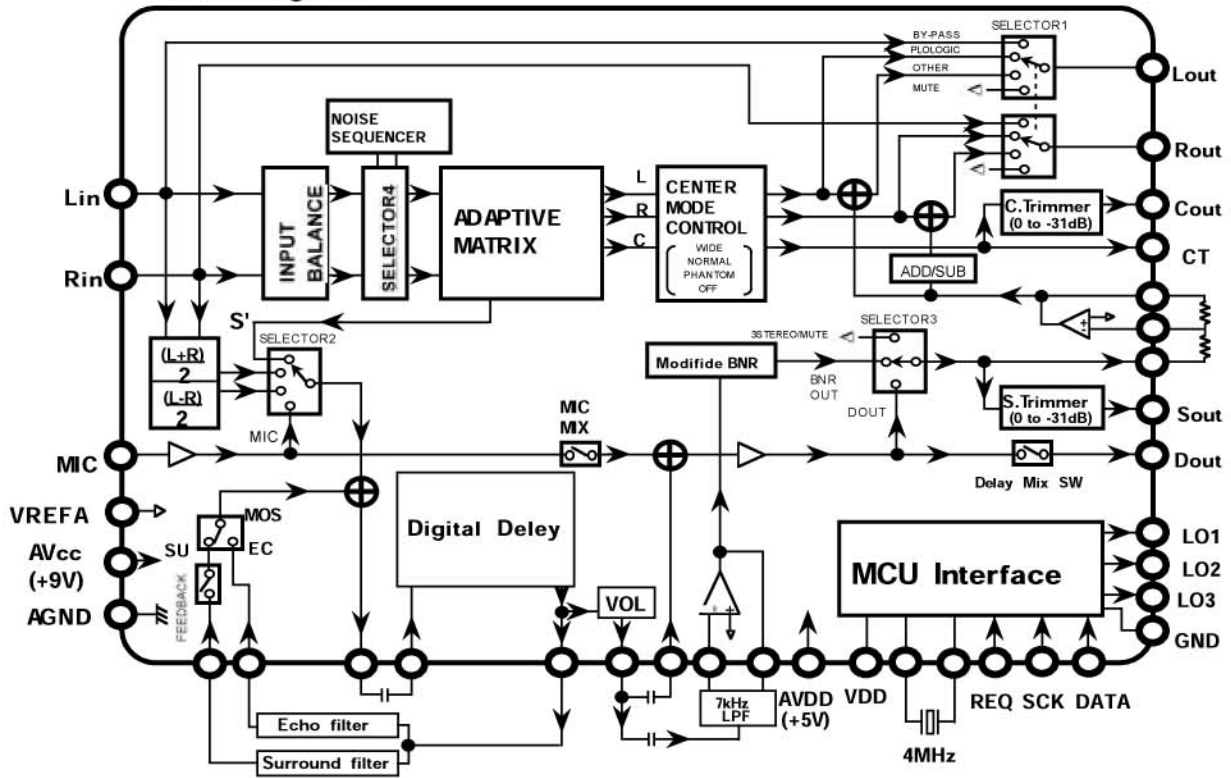

Block name	Function
INPUT BALANCE	Revises a level error between the input Lch and Rch for optimum decoder performance.
NOISE SEQUENCER	A simple noise sequencer circuit for aadjustment of output level.
ADAPTIVE MATRIX	Contineuously analyze the two-channel matrixed audio input to determine the direction and relative magnitude of encoded soundfield.
CENTER MODE CONTROL	Possible to select 4 - center mode position. (WIDE,NORMAL,PHANTOM,OFF)
C.Trimmer S.Trimmer	This is the level aadjustment volum of Cch and Sch. (0 to -30 dB : 1dB/step)

PRELIMINARY

Notice ; This is not a final specification.
some parametric limits are subject to change.

MITSUBISHI SOUND PROCESSORS

M62465FP

Dolby Pro Logic Surround

Block name	Function
Modifide BNR	This block restores the signal to its original spectrum while reducing noise and certain crosstalk signals in a final stage of the surround chain.
ADD/SUB	Select a positive phase signal or a negative phase signal with DIGITAL SPACE SURROUND MODE.
SELECTOR1	This is a selective switch to select the output signal of Lout and Rout from BY-PASS,PRO LOGIC,OTHER SUR and MUTE .
SELECTOR2	This is a selective switch to select the output signal of Sout from S',L+R,L-R and MIC.
SELECTOR3	This is a selective switch to select the output signal of Sout from BNRout,Dout and 3STEREO/MUTE.
SELECTOR4	This is a switch to connect a simple noise sequencer output to ADAPTIVE MATRIX stage for level ajust-ment.
Digital Deley	Make 7 kinds of delay signal s.(15.4msec to 196.6msec) The delay function and CLK signal stop at the time of DELAY OFF MODE This mode is for suppress bad effect of digital noize.
FEEDBACK	This is a switch to select feedback mode(ON/OFF) for SURROUND MODE .
MODE SEL(MOS)	This is a switch to select a feedback signal from surround signal and echo signal.
VOL	Control the ATT level of delay signal from 3dB to $-\infty$ (12-step)
MIC MIX	This is a switch to mix miclophone signal to a main signal (Lch,Rch).
Delay Mix SW	This is a switch to select output or not a mixed signal to DOUT pin.

PRELIMINARY

Notice ; This is not a final specification.
some parametric limits are subject to change.

MITSUBISHI SOUND PROCESSORS

M62465FP

Dolby Pro Logic Surround

LEVEL DIAGRAM

- Dolby Pro Logic mode

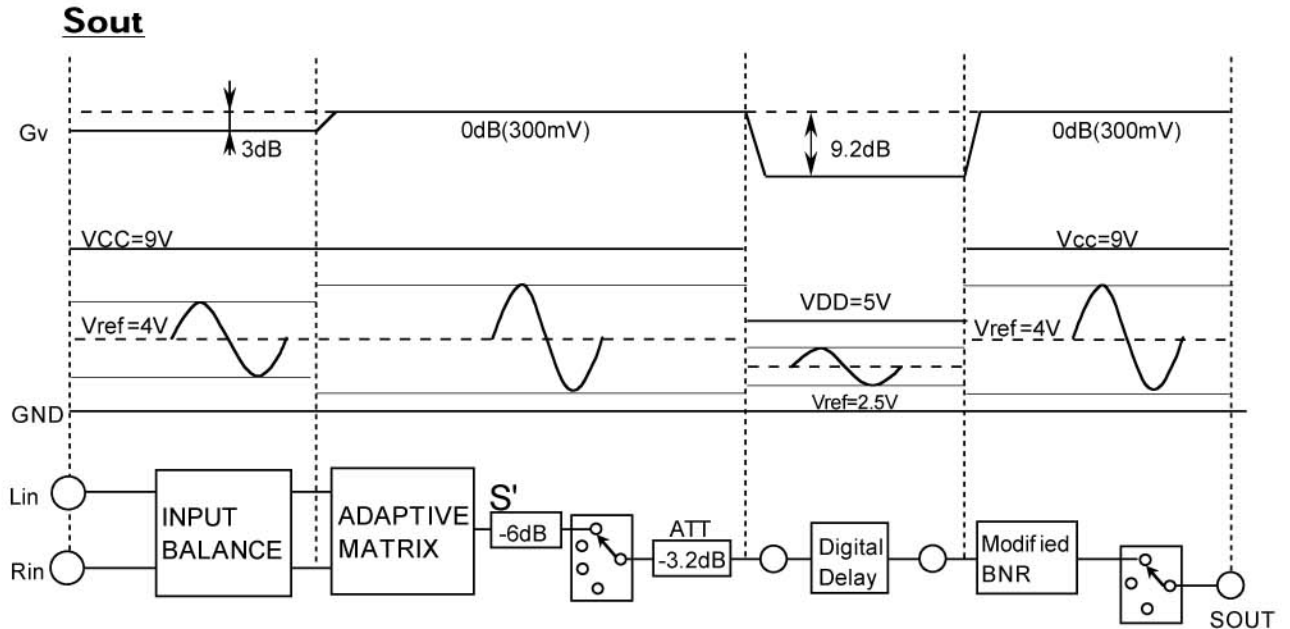

Lout,Rout,Cout

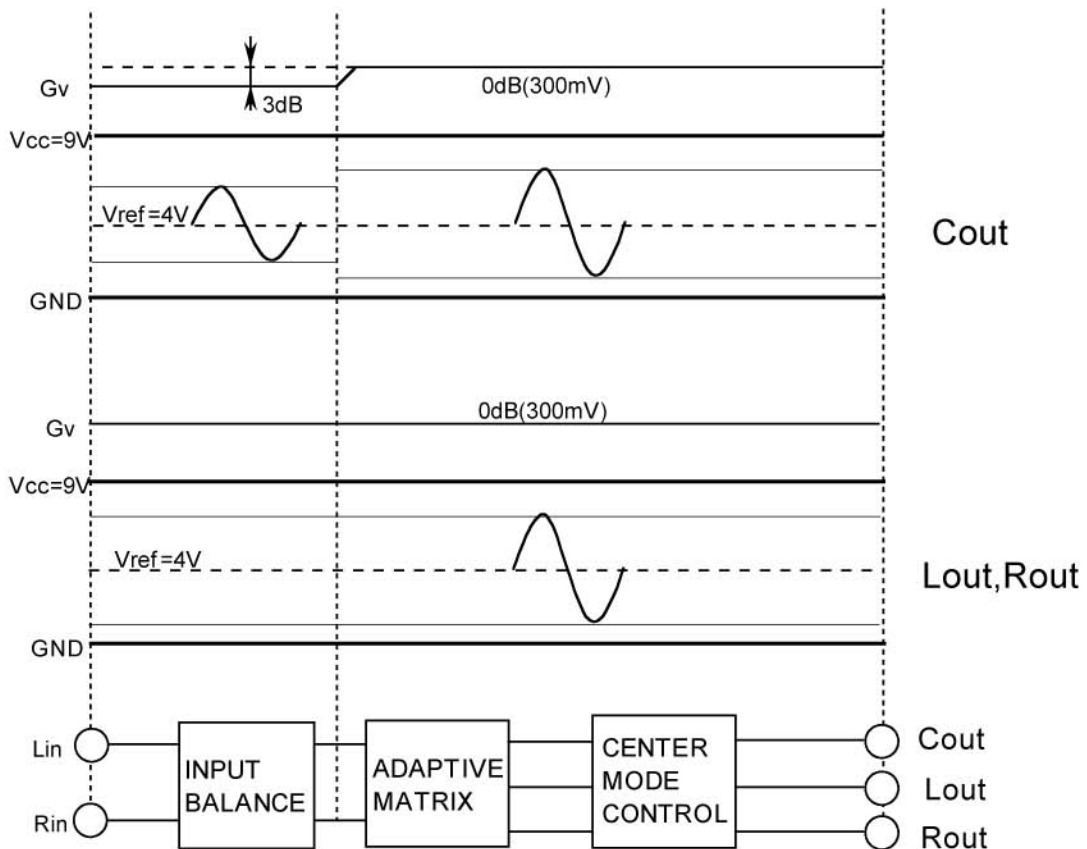

PRELIMINARY

Notice ; This is not a final specification.
some parametric limits are subject to change.

MITSUBISHI SOUND PROCESSORS

M62465FP

Dolby Pro Logic Surround

- Digital Space Surround mode

Sout

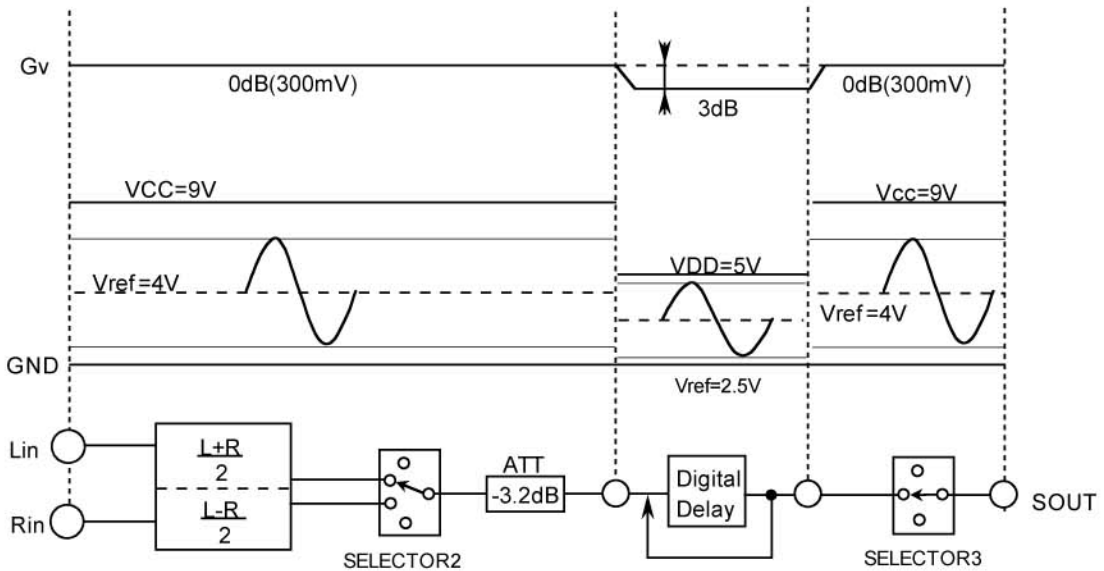

Lout,Rout

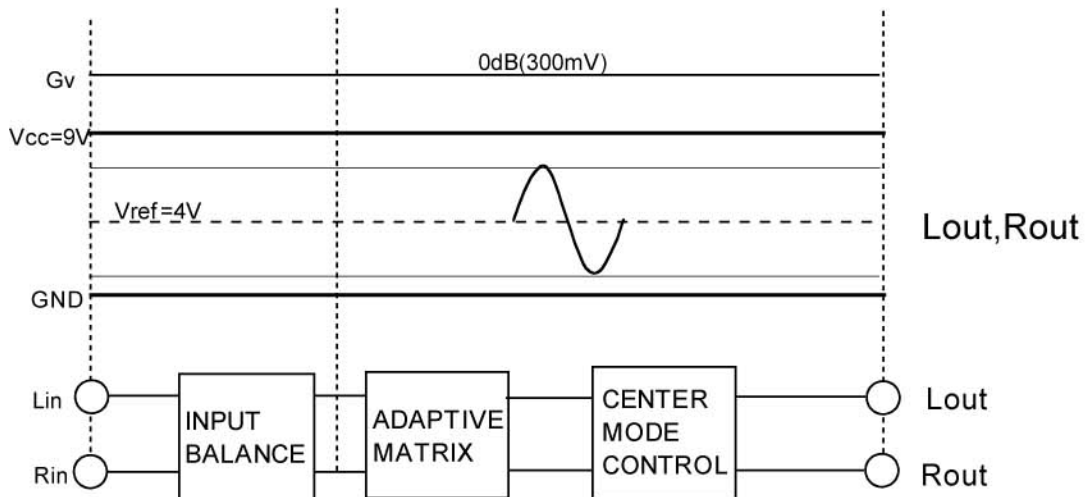

PRELIMINARY

Notice ; This is not a final specification.
some parametric limits are subject to change.

MITSUBISHI SOUND PROCESSORS

M62465FP

Dolby Pro Logic Surround

AUTO MUTE FUNCTION

The IC carries out auto mute function at the time of powering up, delay time setting change, and cancelling delay off mode, in order to suppress shock noise that the digital delay may produce.

- At power up

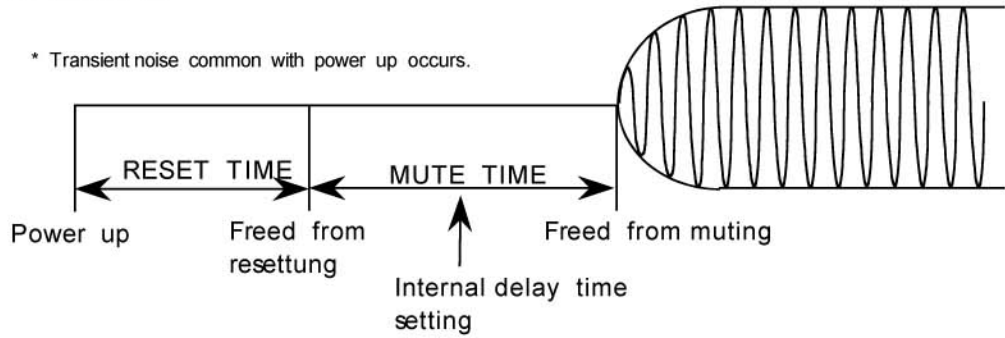

- At delay time setting change

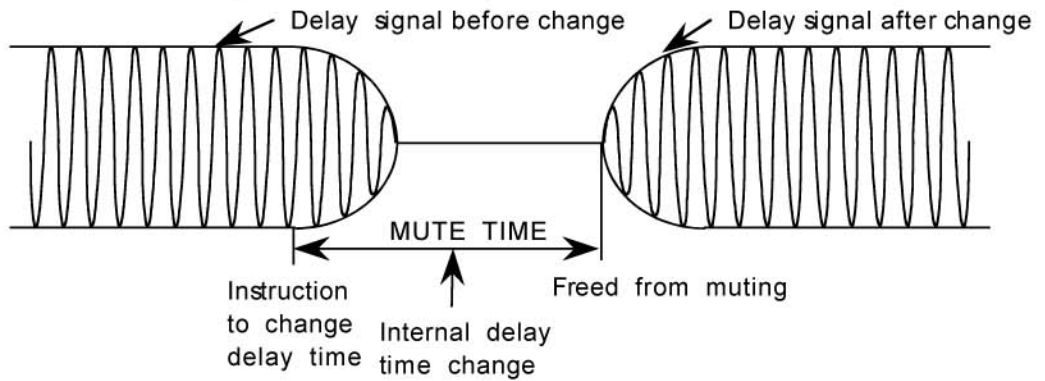

- At canceling delay off mode

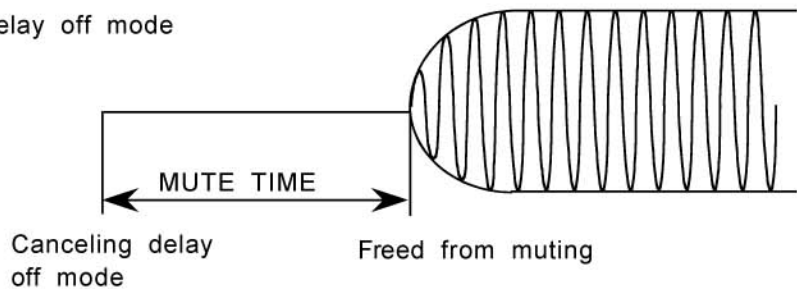

Mute time changes depending on set (or preset) delay time.

DELAY TIME	MUTE TIME
15.4 to 49.2 ms	123 ms
147.5 ,196.6 ms	492 ms

PRELIMINARY

Notice ; This is not a final specification.
some parametric limits are subject to change.

MITSUBISHI SOUND PROCESSORS

M62465FP

Dolby Pro Logic Surround

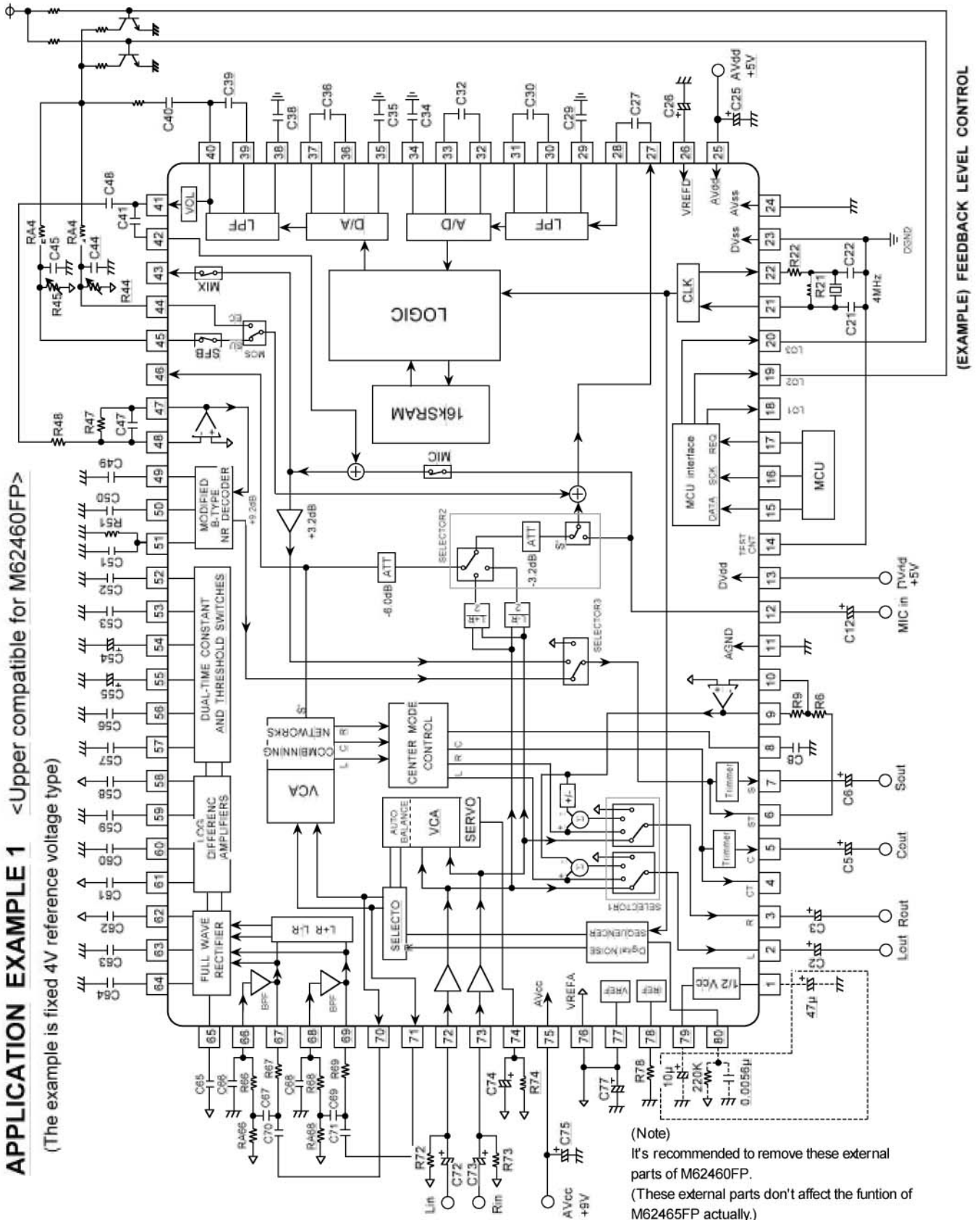

PRELIMINARY

Notice ; This is not a final specification.
some parametric limits are subject to change.

MITSUBISHI SOUND PROCESSORS

M62465FP

Dolby Pro Logic Surround

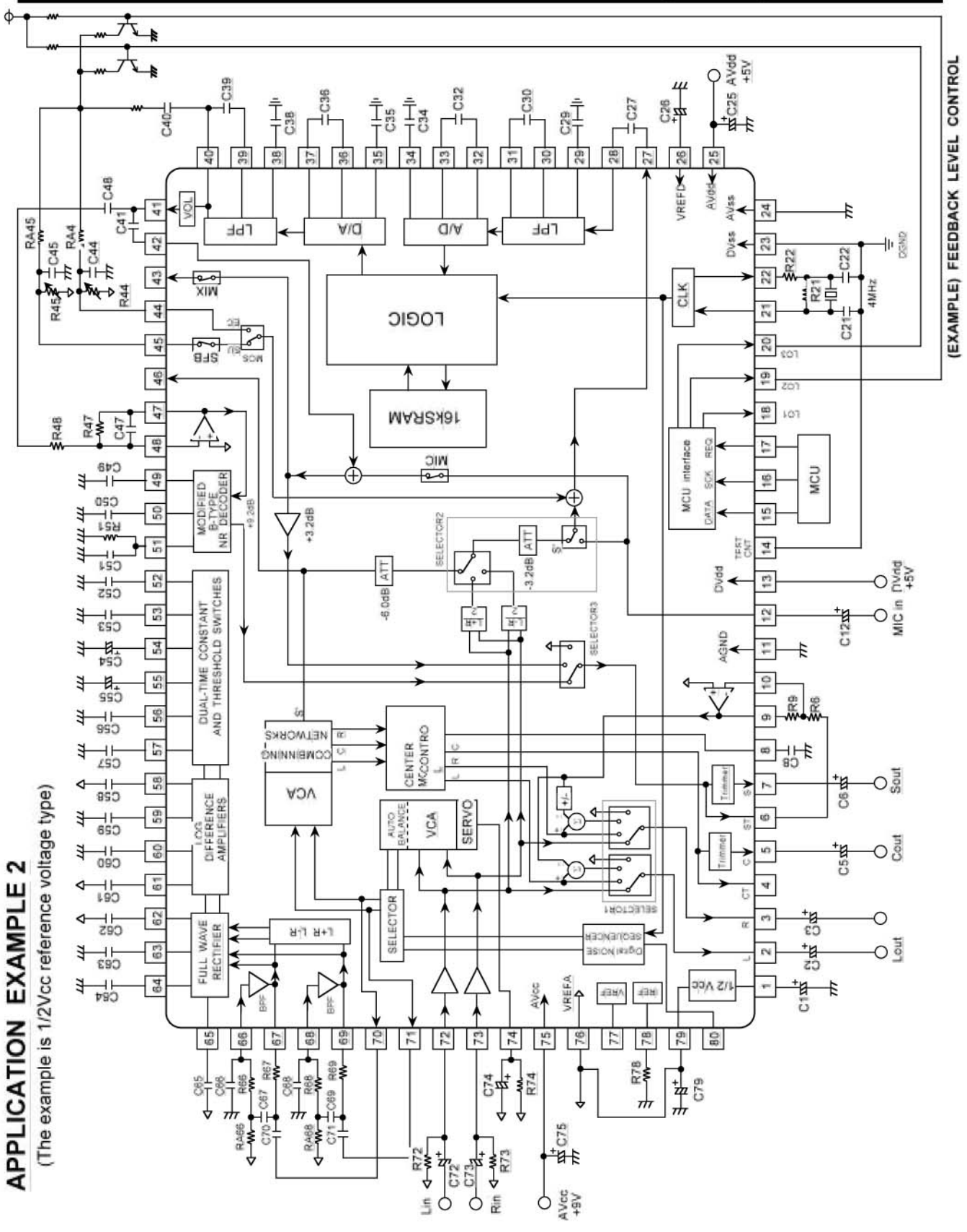

APPLICATION EXAMPLE 2
(The example is 1/2Vcc reference voltage type)

(EXAMPLE) FEEDBACK LEVEL CONTROL

PRELIMINARY

Notice ; This is not a final specification.
some parametric limits are subject to change.

MITSUBISHI SOUND PROCESSORS

M62465FP

Dolby Pro Logic Surround

OPTIONAL PARTS LIST

Parts No.	Values	Unit	Tol.	Parts No.	Values	Unit	Tol.
C1	47	□F		C65	0.1	□F	20%
C2	10	□F		C66	680	pF	5%
C3	10	□F		C67	0.1	□F	5%
C5	10	□F		C68	680	pF	5%
C6	10	□F		C69	0.1	□F	5%
C8	0.1	□F	10%	C70	0.1	□F	5%
C12	1	□F		C71	0.1	□F	5%
C21	27	pF		C72	10	□F	
C22	27	pF		C73	10	□F	
C25	100	□F		C74	22	□F	20%
C26	22	□F		C75	100	□F	
C27	1	□F	5%	C77	220	□F	
C29	0.01	□F	5%	C79	220	□F	
C30	0.0018	□F	5%				
C32	0.068	□F	5%				
C34	0.1	□F	5%				
C35	0.1	□F	5%	R6	10	KΩ	
C36	0.068	□F	5%	R9	20	KΩ	
C38	0.01	□F	5%	R21	1	MΩ	
C39	0.0018	□F	5%	R22	1	KΩ	
C40	0.1	□F		RA44	51	KΩ	
C41	0.1	□F		RA45	51	KΩ	
C44	1200	pF		R44	Vol		
C45	470	pF		R45	Vol		
C47	680	pF	10%	R47	24	KΩ	5%
C48	0.1	□F		R48	24	KΩ	5%
C49	0.0056	□F	5%	R51	330	KΩ	10%
C50	0.047	□F	5%	R66	47	KΩ	5%
C51	0.68	□F	10%	RA66	15	KΩ	5%
C52	0.22	□F	10%	R67	7.5	KΩ	5%
C53	0.22	□F	10%	R68	47	KΩ	5%
C54	4.7	□F	20%	RA68	15	KΩ	5%
C55	4.7	□F	20%	R69	7.5	KΩ	5%
C56	0.22	□F	10%	R72	22	KΩ	
C57	0.22	□F	10%	R73	22	KΩ	
C58	0.1	□F	20%	R74	4.7	MΩ	10%
C59	0.047	□F	5%	R78	100	KΩ	1%
C60	0.047	□F	5%				
C61	0.1	□F	20%				
C62	0.1	□F	20%				
C63	0.022	□F	5%				
C64	0.022	□F	5%				