

TRS-3130G / TRS-3130TG / TRS-3130FG / TRS-3130AG / TRS-3130ATG / TRS-3130AFG
3.3V / 1310 nm / 155 Mbps RoHS Compliant Optical Single-Mode Transceiver

FEATURES

- I Duplex SC Single Mode Transceiver: TRS-3130G
- I Duplex ST Single Mode Transceiver: TRS-3130TG
- I Duplex FC Single Mode Transceiver: TRS-3130FG
- I Intermediate-Reach SONET OC-3 / SDH STM-1 (S-1.1) Compliant
- I Industry Standard 1 x 9 Footprint
- I Single +3.3 V Power Supply
- I **RoHS Compliant**
- I 0 to 70 °C Operating: TRS-3130G
- I -40 to 85 °C Operating: TRS-3130AG
- I PECL Signal Detection Output
- I LED Multisourced 1 x 9 Transceiver Interchangeable
- I Wave Solderable and Aqueous Washable
- I Class 1 Laser International Safety Standard IEC 825 Compliant

DESCRIPTION

The TRS-3130G series single mode transceivers is low power, high performance module for bi-directional serial optical data communications such as SONET OC-3 / SDH STM-1 (S-1.1) and Fast Ethernet. This module is designed for single mode fiber and operates at a nominal wavelength of 1310 nm. The transmitter section uses a multiple quantum well laser and is a class 1 laser compliant according to International Safety Standard IEC 825. The receiver section uses an integrated InGaAs detector preamplifier (IDP) mounted in an optical header and a limiting post-amplifier IC. A PECL logic interface simplifies interface to external circuitry.

LASER SAFETY

This single mode transceiver is a Class 1 laser product. It complies with IEC 825 and FDA 21 CFR 1040.10 and 1040.11. The transceiver must be operated within the specified temperature and voltage limits. The optical ports of the module shall be terminated with an optical connector or with a dust plug.

APPLICATIONS

- I ATM 155 Mbps Links
- I SONET/SDH Equipment Interconnect
- I Fast Ethernet 100 Mb/s Links

ORDER INFORMATION

P/No.	Bit Rate (Mb/s)	SONET /SDH	Distance (km)	Wavelength (nm)	Voltage (V)	Package	Temp. (°C)	TX Power (dBm)	RX Sens. (dBm)	RoHS Compliant
TRS-3130G	155	IR-1/S-1.1	30	1310	3.3	1X9 SC/ST/FC	0 to 70	-8 to -15	-34	Y
TRS-3130AG	155	IR-1/S-1.1	30	1310	3.3	1X9 SC/ST/FC	-40 to 85	-8 to -15	-34	Y

Absolute Maximum Ratings

Parameter	Symbol	Min	Max	Units	Notes
Storage Temperature	Tstg	-40	85	°C	
Operating Temperature	Topr	0 -40	70 85	°C	TRS-3130G TRS-3130AG
Soldering Temperature	---		260	°C	10 seconds on leads only
Power Supply Voltage	Vcc	0	4.5	V	
Input Voltage	---	GND	Vcc	V	
Output Current	Iout	0	30	mA	

Recommended Operating Conditions

Parameter	Symbol	Min	Typ	Max	Units
Power Supply Voltage	Vcc	3.1	3.3	3.5	V
Operating Temperature	Topr	0 -40		70 85	°C / TRS-3130G °C / TRS-3130AG
Data Rate			155		Mb/s
Power Supply Current	Icc			240	mA

Transmitter Specifications (0°C < Topr < 70°C, 3.1V < Vcc < 3.5V)						
Parameter	Symbol	Min	Typ	Max	Units	Notes
Optical						
Optical Transmit Power	Po	-15	---	-8	dBm	1
Output Center Wavelength	λ	1261	1310	1360	nm	
Output Spectrum Width	$\Delta\lambda$	---	---	7.7	nm	RMS (σ)
Extinction Ratio	ER	8.2	---	---	dB	
Output Eye	Compliant with Bellcore TR-NWT-000253 and ITU recommendation G.957					
Optical Rise Time	tr			2	ns	10% to 90% Values
Optical Fall Time	tf			2	ns	10% to 90% Values
Relative Intensity Noise	RIN			-116	dB/Hz	
Total Jitter	TJ			1	ns	2
Electrical						
Data Input Current – Low	IIL	-350			μ A	
Data Input Current – High	IiH			350	μ A	
Differential Input Voltage	V _{IH} - V _{IL}	300			mV	
Data Input Voltage – Low	V _{IL} - V _{CC}	-2.0		-1.58	V	3
Data Input Voltage -- High	V _{IH} - V _{CC}	-1.1		-0.74	V	3

- Notes: 1. Output power is power coupled into a 9/125 μ m single mode fiber.
 2. Measured with a 2²³-1 PRBS with 72 ones and 72 zeros.
 3. These inputs are compatible with 10K, 10KH and 100K ECL and PECL inputs.

Receiver Specifications (0°C < Topr < 70°C, 3.1V < Vcc < 3.5V)						
Parameter	Symbol	Min	Typ	Max	Units	Notes
Optical						
Sensitivity	---	---	---	-34	dBm	1
Maximum Input Power	Pin	-3		---	dBm	
Signal Detect -- Asserted	Pa	---	---	-34	dBm	Transition: low to high
Signal Detect -- Deasserted	Pd	-47	---	---	dBm	Transition: high to low
Signal detect -- Hysteresis		1.0	---	4.0	dB	
Wavelength of Operation		1100	---	1600	nm	
Electrical						
Data Output Voltage – Low	V _{OL} - V _{CC}	-2.0		-1.58	V	2
Data Output Voltage – High	V _{OH} - V _{CC}	-1.1		-0.74	V	2
Signal Detect Output Voltage -- Low	V _{OL} - V _{CC}	-2.0		-1.58	V	
Signal Detect Output Voltage -- High	V _{OH} - V _{CC}	-1.1		-0.74	V	

- Notes: 1. Minimum sensitivity and saturation levels at BER=1E-10 for a 2²³-1 PRBS with 72 ones and 72 zeros.
 2. These outputs are compatible with 10K, 10KH and 100K ECL and PECL outputs.

CONNECTION DIAGRAM

Receiver Signal Ground	1 (Rx GND)	○
Receiver Data Out	2 (RD+)	N/C
Receiver Data Out Bar	3 (RD-)	
Signal Detect	4 (SD)	
Receiver Power Supply	5 (Rx Vcc)	TOP VIEW
Transmitter Power Supply	6 (Tx Vcc)	
Transmitter Data In Bar	7 (TD-)	
Transmitter Data In	8 (TD+)	N/C
Transmitter Signal Ground	9 (Tx GND)	○

PIN	Symbol	Notes
1	Rx GND	Directly connect this pin to the receiver ground plane
2	RD+	See recommended circuit schematic
3	RD-	See recommended circuit schematic
4	SD	Active high on this indicates a received optical signal
5	Rx Vcc	+3.3V dc power for the receiver section
6	Tx Vcc	+3.3V dc power for the transmitter section
7	TD-	See recommended circuit schematic
8	TD+	See recommended circuit schematic
9	Tx GND	Directly connect this plan to the transmitter ground plane

RECOMMENDED CIRCUIT SCHEMATIC

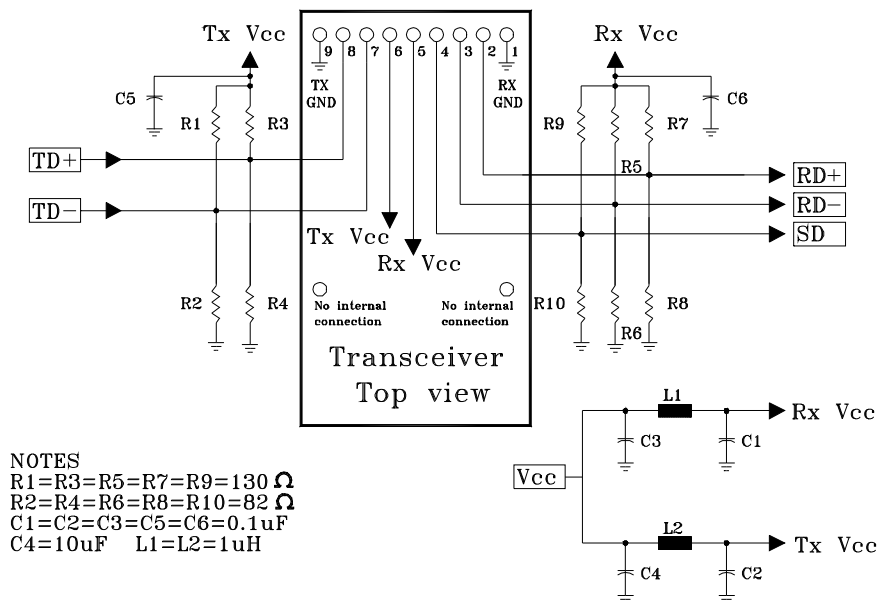

The split-load terminations for ECL signals need to be located at the input of devices receiving those ECL signals. The power supply filtering is required for good EMI performance. Use short tracks from the inductor L1/L2 to the module Rx Vcc and Tx Vcc. A GND plane under the module is required for good EMI and sensitivity performance.

PACKAGE DIAGRAM

Units in mm

1) SC Type

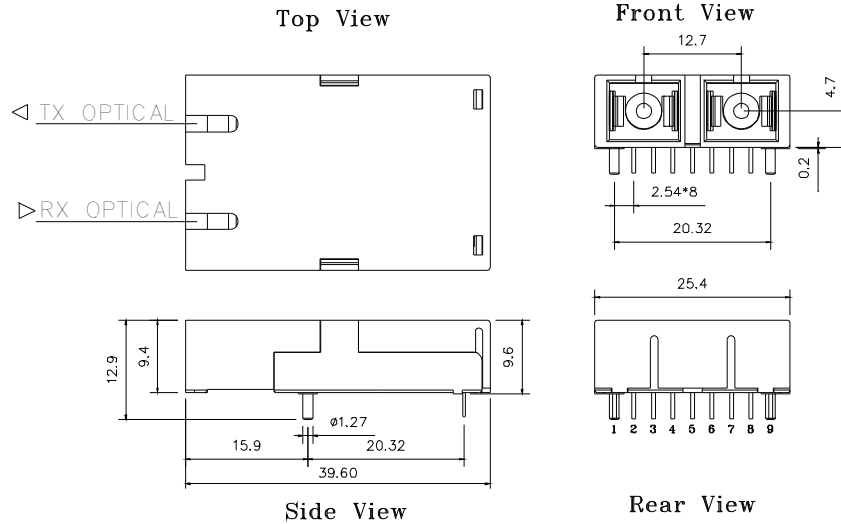

TRS-3130G / TRS-3130AG

2) ST Type

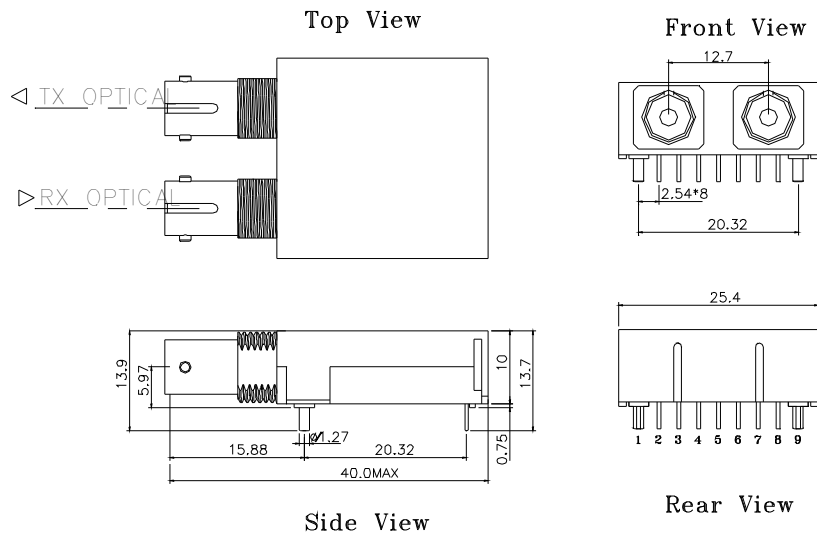

TRS-3130TG / TRS-3130ATG

3) FC Type

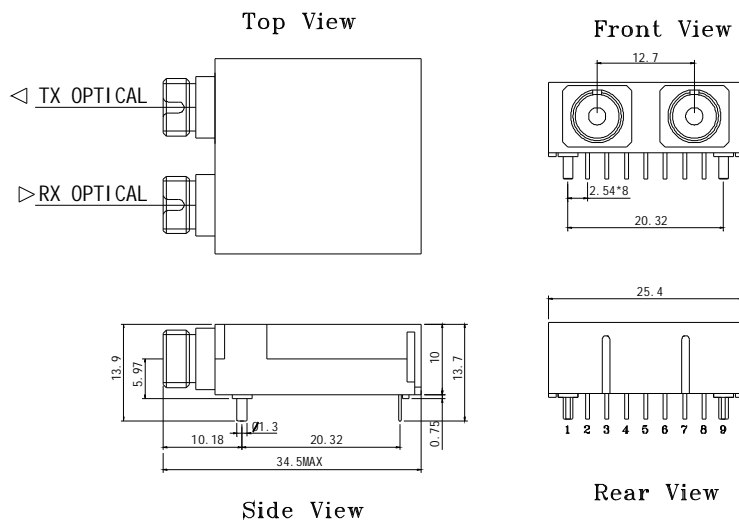

TRS-3130FG / TRS-3130AFG

Note: Specifications subject to change without notice.