

FEATURES

- Compatible with Leading Chip Sets
- 2kVrms Isolation
- Standard Pinout
- Surface Mount Option
- CECC00802 Reflow (280°C)
- UL 94V-0 Package Materials
- Low Profile
- Suitable for Both 75 & 110Ω Circuits
- Lead Free Compatible

DESCRIPTION

The Digital Audio Range of transformers is designed to improve the balance of transmitter and receiver circuitry in hi-fi equipment, video games and other applications requiring high-performance digital audio transmission. Compliant with AES/EBU recommendations for the digital audio interface offering optimised shunt capacitance between primary and secondary windings. Capable of operating over the audio data rate frequency range, providing isolation from 60Hz noise.

SELECTION GUIDE

Order Code	Turns Ratio & Phase	Primary Inductance 10kHz 10mV mH	Leakage Inductance MAX 100kHz, 10mV µH	ET Constant MIN Vµs	Return Loss MIN 100kHz - 3MHz dB	Common Mode Rejection TYP 100kHz, 110Ω dB	Package Style
DA101	1:1	1.00 - 1.59	0.22	15	46.80	52.10	DIP
DA102	1:1	2.00 - 3.00	0.39	20	40.40	49.70	
DA103	1:1	4.00 - 5.96	0.91	28	36.30	46.40	
DA101M/R	1:1	1.00 - 1.59	0.22	15	46.80	52.10	SM
DA102M/R	1:1	2.00 - 3.00	0.39	20	40.40	49.70	
DA103M/R	1:1	4.00 - 5.96	0.91	28	36.30	46.40	

ABSOLUTE MAXIMUM RATINGS

Operating free air temperature range	0°C to 70°C
Storage temperature range	-40°C to 125°C

Specifications typical at T_A = 25°C
For tape and reel packaging details refer to datasheet NDC AN002.

DA100 SERIES

Transformers for Digital Audio Data Transmission

MECHANICAL DIMENSIONS

6 Pin DIP

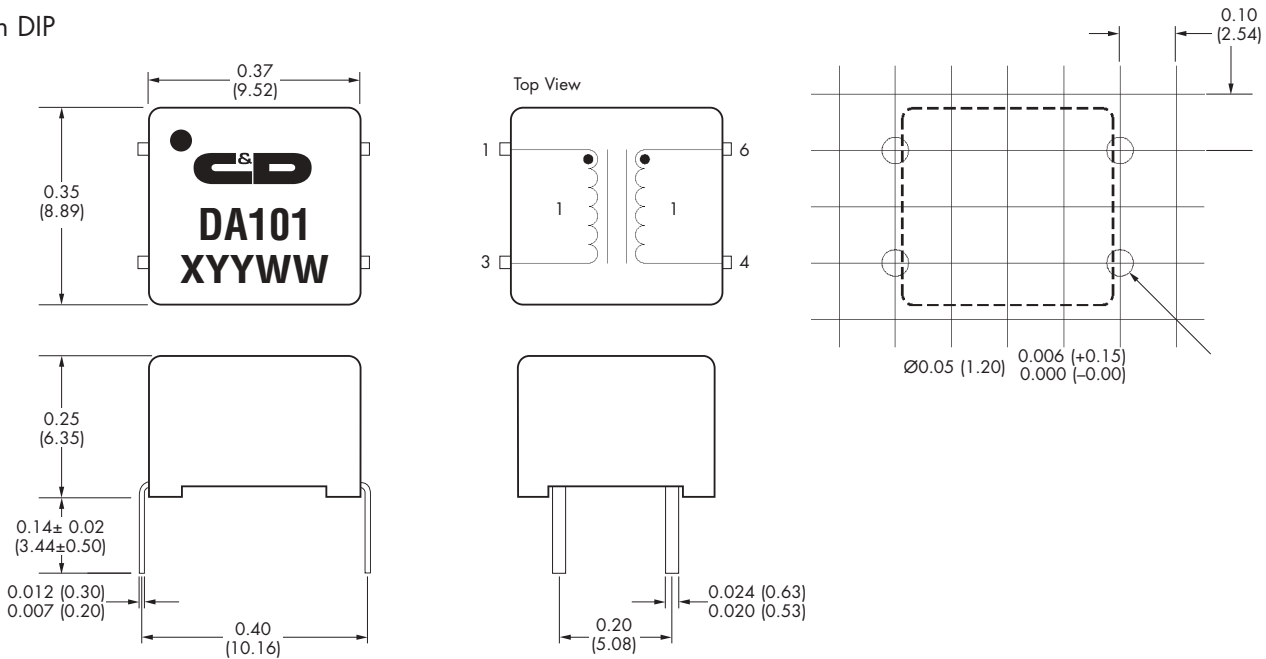

6 Pin SM

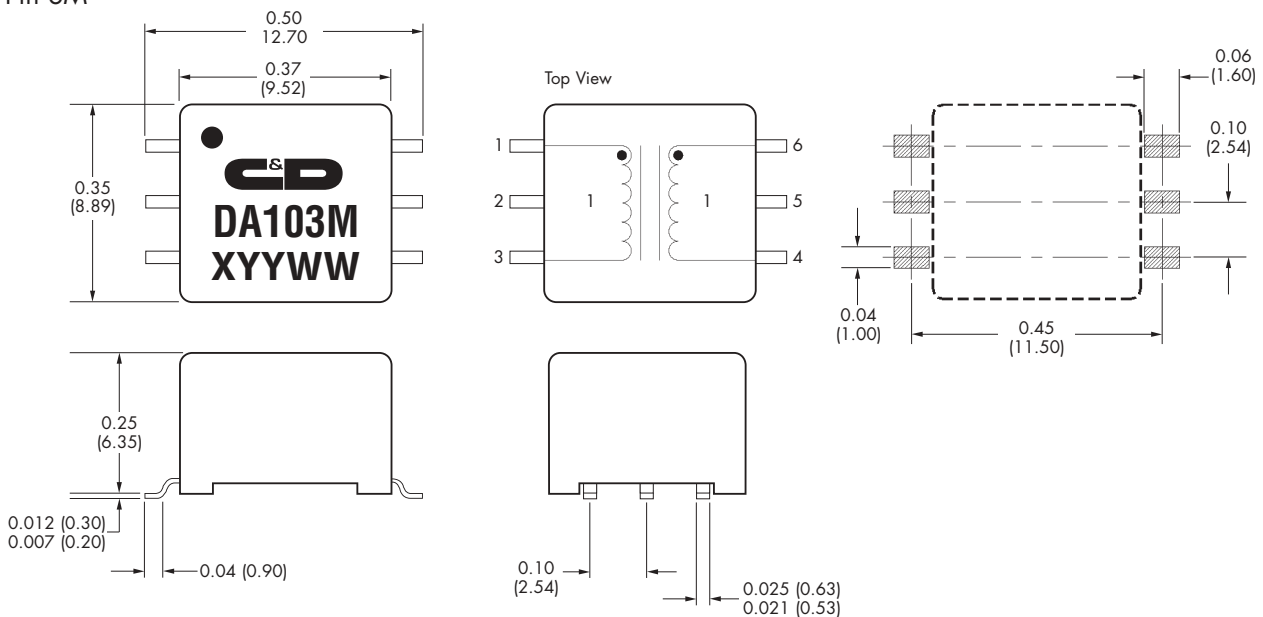

All dimensions in mm XX.XX ±0.25mm. All pins on a 2.54mm pitch and within ±0.25mm of true position.

C&D Technologies (NCL) Limited reserve the right to alter or improve the specification, internal design or manufacturing process at any time, without notice. Please check with your supplier or visit our web site to ensure that you have the current and complete specification for your product before use.

© C&D Technologies (NCL) Limited 2002

NMP DA100.4

No part of this publication may be copied, transmitted or stored in a retrieval system or reproduced in any way including, but not limited to, photography, photocopy, magnetic or other recording means, without prior written permission from C&D Technologies (NCL) Limited.

Instructions for use are available from www.cdpoweronline.com

C&D Technologies (NCL) Ltd
Tanners Drive, Blakelands North
Milton Keynes MK14 5BU, England
Tel: +44 (0)1908 615232
Fax: +44 (0)1908 617545
email: info@cdtechno-ncl.com

www.cdpoweronline.com

C&D Technologies Inc.
3400 E Britannia Drive, Tucson,
Arizona 85706, USA
Tel: +1 (800) 547-2537
Fax: +1 (520) 741-4598
email: sales@cdtechno.com

C&D TECHNOLOGIES
Power Solutions