

|                |   |
|----------------|---|
| Structure      | Silicon Monolithic Integrated Circuit   |
| Product Series | 4ch Sensorless System Motor Driver for MD   |
| Type           | <b>BD6640KVT</b>  |
| Features       | <ul style="list-style-type: none"> <li>• Operates at low power supply voltage (2.1V min)</li> <li>• Power DMOS output with low ON resistance (0.8Ω Typ.)</li> <li>• Incorporates a charge pump circuit for VG boost.</li> <li>• 3-phase full-wave soft-switching sensorless driver for spindle</li> <li>• 3-value control 3-phase driver for sled (built-in comparator for BEMF voltage detection)</li> <li>• 2ch, 3-value control H-bridges for focus/tracking</li> <li>• PWM half-bridge for spindle VM power supply</li> </ul> |

○Absolute maximum ratings(Ta=25°C)

| Parameter                                 | Symbol | Limit    | Unit |
|---|--------|----------|------|
| Power supply voltage for control circuit  | VCC    | 7        | V    |
| Power supply voltage for driver block     | VM     | 7        | V    |
| Power supply voltage for pre-driver block | VG     | 14       | V    |
| Input voltage                             | VIN    | 0~VCC    | V    |
| Output current                            | Iomax  | *500     | mA   |
| Power dissipation                         | Pd     | **1250   | mW   |
| Operating temperature range               | Topr   | -25~+75  | °C   |
| Storage temperature range                 | Tstg   | -55~+150 | °C   |
| Junction temperature                      | Tjmax  | +150     | °C   |

\* Must not exceed Pd or ASO, Tjmax=150°C.

\* \* Reduced by 10mW/°C over Ta=25°C, when mounted on a glass epoxy board (70mm×70 mm×1.6mm).

○Operating conditions (Ta=-25~+75°C)

| Parameter             | Symbol | Min. | Typ. | Max | Unit |
|-----------------------|--------|------|------|-----|------|
| Power supply voltage  | VCC1,2 | 2.1  | 2.2  | 6.5 | V    |
|                       | VM     | -    | -    | 5.0 | V    |
|                       | VG     | 3    | 6.5  | 13  | V    |
| Pulse input frequency | fin    | -    | -    | 500 | kHz  |

This product described in this specification is not judged whether it applies to COCOM regulations.

Please confirm in case of export.

This product is not designed for protection against radioactive rays.

## ○Electrical characteristics

(Unless otherwise specified, Ta=25°C, VCC1, 2=2.2V, VM=1.0V, fin=176kHz)

| Parameter  | Symbol | Limit   |      |       | Unit | Conditions                                    |
|--|--------|---------|------|-------|------|---|
|  |        | Min.    | Typ. | Max.  |      |   |
| Circuit current  | ICC    | -       | 4.4  | 7.0   | mA   | at operation in all blocks                    |
|  | IST    | -       | 1    | 10    | μA   | at standby in all blocks                      |
| Output ON resistance   | RON    | -       | 0.8  | 1.2   | Ω    | upper and lower ON resistance in total VG=10V |
| ~Boost circuit~  |        |         |      |       |      |   |
| Output voltage   | VG1    | 5.5     | 6.5  | 6.7   | V    | each input L                                  |
|  | VG2    | 4.4     | 5.2  | —     | V    | at operation in all blocks                    |
| ~Oscillation circuit~  |        |         |      |       |      |   |
| Self-propelled oscillating frequency   | fOSC   | 50      | 100  | 160   | kHz  |   |
| External clock synchronous range   | fSYNC  | —       | —    | 500   | kHz  | input from EXTCLK pin                         |
| ~Spindle (3-phase full-wave sensorless driver) block~  |        |         |      |       |      |   |
| Position detection comparator  | VCO    | -10     | —    | +10   | mV   |   |
| Detection comparator input range   | VCD    | 0       | —    | VCC-  | V    |   |
| CST charge current   | ICTO   | -3.5    | -2.1 | -0.9  | μA   | CST=1V  |
| CST discharge current  | ICTI   | 1.0     | 3.6  | 7.5   | mA   | CST=1V  |
| CSL charge current   | ICLO   | -3.5    | -7.5 | -13   | μA   | CSL=0.5V                                      |
| CSL discharge current  | ICLI   | 1.2     | 3.0  | 6.5   | μA   | CSL=0.5V                                      |
| CSL clamp H voltage  | VCLH   | 0.7     | 0.8  | 0.9   | V    |   |
| Brake comparator input current   | IBR    | —       | —    | 2.0   | μA   | BRK=VCC                                       |
| Brake comparator input offset  | VBO    | -15     | —    | +15   | mV   |   |
| Brake comparator input range   | VBD    | 0       | —    | VCC-1 | V    |   |
| FG output pull-up resistance   | RBF    | 10      | 20   | 30    | kΩ   |   |
| FG output L voltage  | VOLF   | —       | 0.2  | 0.3   | V    | Io=300μA                                      |
| RIB offset voltage   | VRO    | 10      | 18   | 30    | mV   | VM=0V RIB=500Ω                                |
| Pre-drive loop gain  | VRP    | 500     | 650  | 850   | mV   |   |
| M-phase check  | VMCK   | 400     | 500  | 600   | mV   |   |
| ~Sled, focus, tracking, PWM power supply (stepping, H-bridge, and half-bridge driver) block~ |        |         |      |       |      |   |
| Logic H level input voltage  | VINH   | VCC-0.4 | —    | VCC   | V    |   |
| Logic L level input voltage  | VINL   | 0       | —    | 0.4   | V    |   |
| Logic H level input current  | IINH1  | —       | —    | 1     | μA   | VIN=2.2V                                      |
|  | IINH2  | —       | 350  | 600   | μA   | VIN=2.2V EXTCLK pin                           |
| Logic L level input current  | IINL   | -1      | —    | —     | μA   | VIN=0V  |
| Output propagation delay time  | TRISE  | —       | 0.2  | 1     | μsec |   |
|  | TFALL  | —       | 0.1  | 0.7   | μsec |   |
| Short pulse response   | tmin   | 120     | —    | —     | nsec | input pulse width 200 ns                      |

©This product is not designed for protection against radioactive rays.

OPackage outlines

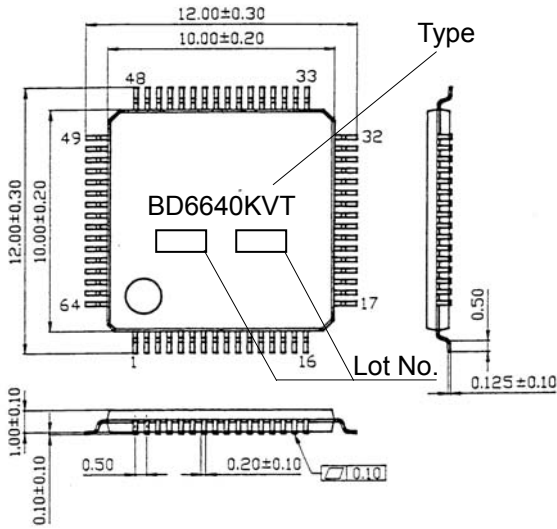

TQFP64V outlines (Unit : mm)

OBlock diagram

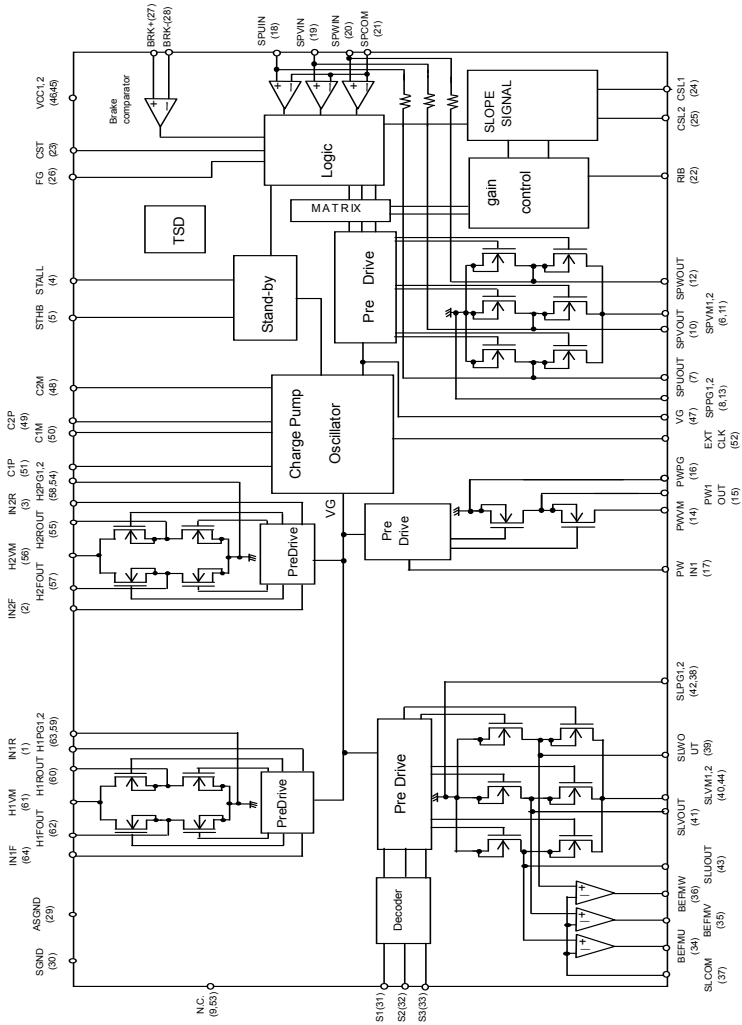

OPin No./Pin name

| NO. | Pin name | NO. | Pin name |
|-----|----------|-----|----------|
| 1   | IN1R     | 33  | S3       |
| 2   | IN2F     | 34  | BEMFU    |
| 3   | IN2R     | 35  | BEMFV    |
| 4   | STALL    | 36  | BEMFW    |
| 5   | STHB     | 37  | SLCOM    |
| 6   | SPVM1    | 38  | SLPG2    |
| 7   | SPUOUT   | 39  | SLWOUT   |
| 8   | SPPG1    | 40  | SLVM2    |
| 9   | N.C      | 41  | SLVOUT   |
| 10  | SPVOUT   | 42  | SLPG1    |
| 11  | SPVM2    | 43  | SLUOUT   |
| 12  | SPWOUT   | 44  | SLVM1    |
| 13  | SPPG2    | 45  | VCC2     |
| 14  | PWVM     | 46  | VCC1     |
| 15  | PWOUT    | 47  | VG       |
| 16  | PWPG     | 48  | C2M      |
| 17  | PWIN1    | 49  | C2P      |
| 18  | SPUIN    | 50  | C1M      |
| 19  | SPVIN    | 51  | C1P      |
| 20  | SPWIN    | 52  | EXTCLK   |
| 21  | SPCOM    | 53  | N.C      |
| 22  | RIB      | 54  | H2PG2    |
| 23  | CST      | 55  | H2ROUT   |
| 24  | CSL1     | 56  | H2VM     |
| 25  | CSL2     | 57  | H2FOUT   |
| 26  | FG       | 58  | H2PG1    |
| 27  | BRK+     | 59  | H1PG2    |
| 28  | BRK-     | 60  | H1ROUT   |
| 29  | ASGND    | 61  | H1VM     |
| 30  | SGND     | 62  | H1FOUT   |
| 31  | S1       | 63  | H1PG1    |
| 32  | S2       | 64  | IN1F     |

ONotes on the use

- (1) Absolute maximum ratings  
If the input voltage or the operating temperature range exceeds absolute maximum ratings, IC may be damaged. No destruction mode (e.g., short-circuiting or open) can be specified in that case. If such special mode as will exceed absolute maximum ratings is assumed, take the physical safety measures, such as a fuse.
- (2) Power supply lines  
The regenerated current by BEMF of the motor will return. Therefore, take measures, such as the insertion of a capacitor between the power supply and GND as the pass of the regenerated current. Determine the capacitance in full consideration of all the characteristics of the electrolytic capacitor, because the electrolytic capacitor may loose some capacitance at low temperatures. If the connected power supply does not have sufficient current absorption capacity, regenerative current will cause the voltage of the power supply line to rise, which the product and its peripheral circuit may exceed the absolute maximum ratings. It is recommended to implement physical safety measures such as the insertion of a voltage clamp diode between the power supply and GND pins.
- (3) Ground potential  
Ensure a minimum GND pin potential in all operating conditions.
- (4) Design for heat  
Use the design for heat that allows for a sufficient margin in light of the power dissipation (Pd) in actual using conditions.
- (5) Operation in strong magnetic field  
Use caution when using the IC in the strong magnetic field as doing so may cause the IC to malfunction.
- (6) ASO  
When using the IC, make settings so that the output transistors for the motor will not be used under conditions in excess of the absolute maximum ratings and ASO.
- (7) Thermal shutdown circuit  
This IC incorporates thermal shutdown circuit(TSD circuit).  
When the chip temperature becomes the one shown in below, TSD circuit operates and makes the coil output to motor open. It is designed to shut the IC off from runaway thermal operation. It is not designed to protect the IC or guarantee its operation. Do not continue to use the IC after operating this circuit or use the IC in an environment where the operation of this circuit is assumed.

| TSD ON temperature[°C] (typ.) | Hysteresis temperature [°C] (typ.) |
|-------------------------------|------------------------------------|
| 175                           | 20                                 |

- (8) Ground wiring pattern  
When having both small signal and large current GND, it is recommended to isolate the two GND patterns, placing a single ground point at the application's reference point so that the pattern wiring resistance and voltage variations caused by large currents do not cause voltage variations of the small signal GND. Be careful not to change the GND wiring pattern of any external parts, either.

## Notes

No copying or reproduction of this document, in part or in whole, is permitted without the consent of ROHM Co.,Ltd.

The content specified herein is subject to change for improvement without notice.

The content specified herein is for the purpose of introducing ROHM's products (hereinafter "Products"). If you wish to use any such Product, please be sure to refer to the specifications, which can be obtained from ROHM upon request.

Examples of application circuits, circuit constants and any other information contained herein illustrate the standard usage and operations of the Products. The peripheral conditions must be taken into account when designing circuits for mass production.

Great care was taken in ensuring the accuracy of the information specified in this document. However, should you incur any damage arising from any inaccuracy or misprint of such information, ROHM shall bear no responsibility for such damage.

The technical information specified herein is intended only to show the typical functions of and examples of application circuits for the Products. ROHM does not grant you, explicitly or implicitly, any license to use or exercise intellectual property or other rights held by ROHM and other parties. ROHM shall bear no responsibility whatsoever for any dispute arising from the use of such technical information.

The Products specified in this document are intended to be used with general-use electronic equipment or devices (such as audio visual equipment, office-automation equipment, communication devices, electronic appliances and amusement devices).

The Products specified in this document are not designed to be radiation tolerant.

While ROHM always makes efforts to enhance the quality and reliability of its Products, a Product may fail or malfunction for a variety of reasons.

Please be sure to implement in your equipment using the Products safety measures to guard against the possibility of physical injury, fire or any other damage caused in the event of the failure of any Product, such as derating, redundancy, fire control and fail-safe designs. ROHM shall bear no responsibility whatsoever for your use of any Product outside of the prescribed scope or not in accordance with the instruction manual.

The Products are not designed or manufactured to be used with any equipment, device or system which requires an extremely high level of reliability the failure or malfunction of which may result in a direct threat to human life or create a risk of human injury (such as a medical instrument, transportation equipment, aerospace machinery, nuclear-reactor controller, fuel-controller or other safety device). ROHM shall bear no responsibility in any way for use of any of the Products for the above special purposes. If a Product is intended to be used for any such special purpose, please contact a ROHM sales representative before purchasing.

If you intend to export or ship overseas any Product or technology specified herein that may be controlled under the Foreign Exchange and the Foreign Trade Law, you will be required to obtain a license or permit under the Law.



Thank you for your accessing to ROHM product informations.  
More detail product informations and catalogs are available, please contact us.

### ROHM Customer Support System

<http://www.rohm.com/contact/>