

INTRODUCTION

Fast, easy breadboarding of circuits using the SA51 are possible with the EK-SA51 PC board. Mounting holes are provided and the provision for standard banana jacks simplifies connection and testing. Components are labeled on both sides of the board for ease in probing.

TYPICAL COMPONENT FUNCTIONS

- C2, C3, C4 Power supply bypass capacitors
- R4, C1 Snubber network
- R1 Current sensing resistor or jumpered to ground
- R2, R3 Input resistors

PARTS LIST

Part #	Description	Quantity
EVAL06	P.C. Board	1
HS14	Heatsink	1
MS03	Mating Socket	1
TW03	Thermal Washers	1 bag of 10

EQUIVALENT SCHEMATIC

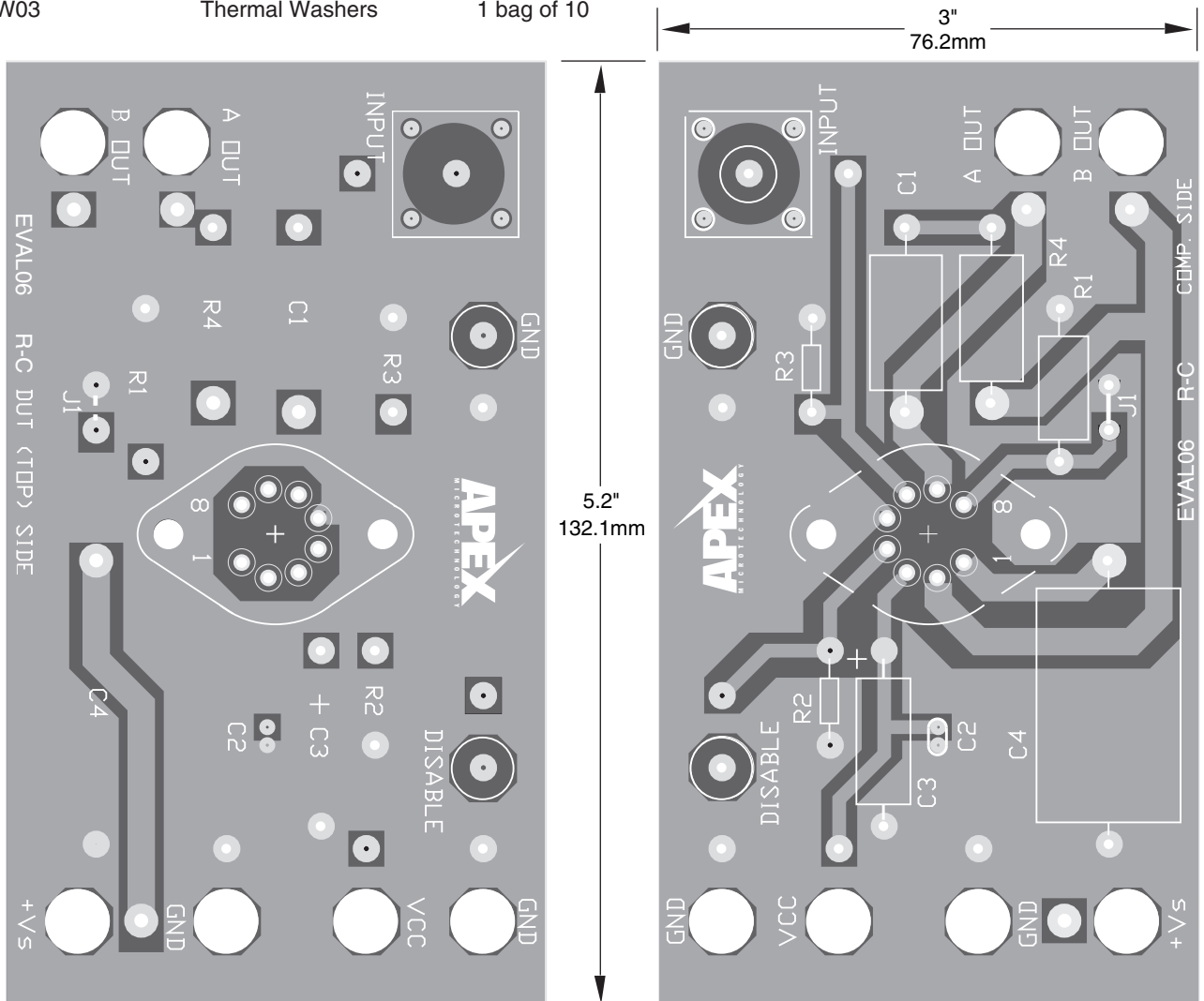
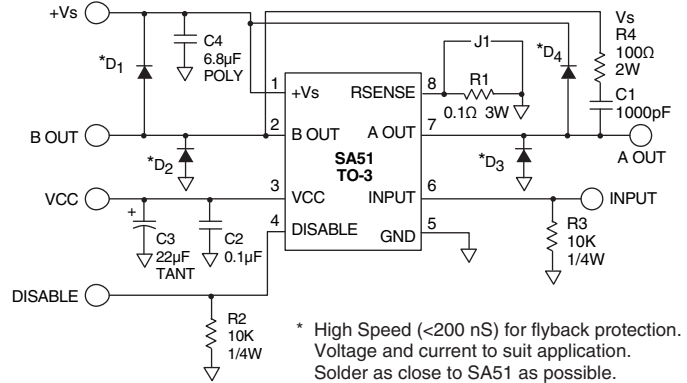

NOTE: Illustration only, not to exact scale.