

**PLEASE CHECK WWW.MOLEX.COM FOR LATEST PART INFORMATION**

**Part Number:** **0002095169**  
**Status:** **Active**  
**Overview:** standard\_093  
**Description:** 2.36mm (.093") Diameter, Standard .093" Pin and Socket Crimp Terminal, Series 4550, Female, with Gold (Au) Plated Phosphor Bronze Contact, 14-20 AWG, Reel

**Documents:**

[Drawing \(PDF\)](#) [RoHS Certificate of Compliance \(PDF\)](#)  
[Product Specification PS-02-09 \(PDF\)](#)

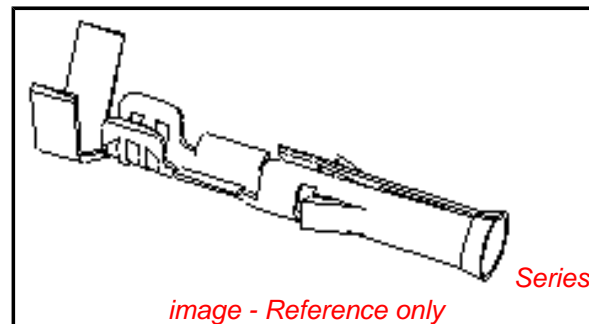

**General**

Product Family	Crimp Terminals
Series	<u>4550</u>
Crimp Quality Equipment	Yes
Overview	<u>standard_093</u>
Product Name	Standard .093"

**Physical**

Gender	Female
Material - Metal	Phosphor Bronze
Material - Plating Mating	Gold
Material - Plating Termination	Nickel
Packaging Type	Reel
Plating min: Mating (µin)	30
Plating min: Mating (µm)	0.75
Plating min: Termination (µin)	50
Plating min: Termination (µm)	1.25
Termination Interface: Style	Crimp or Compression
Wire Insulation Diameter	1.65-4.06mm (.065-.160")
Wire Size AWG	14, 16, 18, 20
Wire Size mm <sup>2</sup>	N/A

**Material Info**

Old Part Number 4550-A(P558)

**Reference - Drawing Numbers**

Product Specification	PS-02-09
Sales Drawing	SD-4550-*

**EU RoHS**

**ELV and RoHS  
Compliant**  
**REACH SVHC  
Not Reviewed**  
**Halogen-Free  
Status**

**China RoHS**



**Not Reviewed**

**Need more information on product  
environmental compliance?**

Email [productcompliance@molex.com](mailto:productcompliance@molex.com)  
 For a multiple part number RoHS Certificate of Compliance, [click here](#)

Please visit the [Contact Us](#) section for any non-product compliance questions.

**Search Parts in this Series**

4550Series

**Application Tooling | [FAQ](#)**

*Tooling specifications and manuals are found by selecting the products below. Crimp Height Specifications are then contained in the Application Tooling Specification document.*

**Global**

Description	Product #
Mini-Mac™ Applicator	<u>0638927100</u>
Mini-Mac™ Applicator	<u>0638927300</u>
Insertion Tool	<u>0011020003</u>
Terminator Die	<u>0011402001</u>

PART NO.	ENG. NO.
02-09-1205	4550-(P901)
02-09-1206	4550-(P901)L
02-09-5169	4550-A(P558)
02-09-5170	4550-A(P558)L

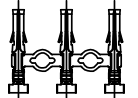
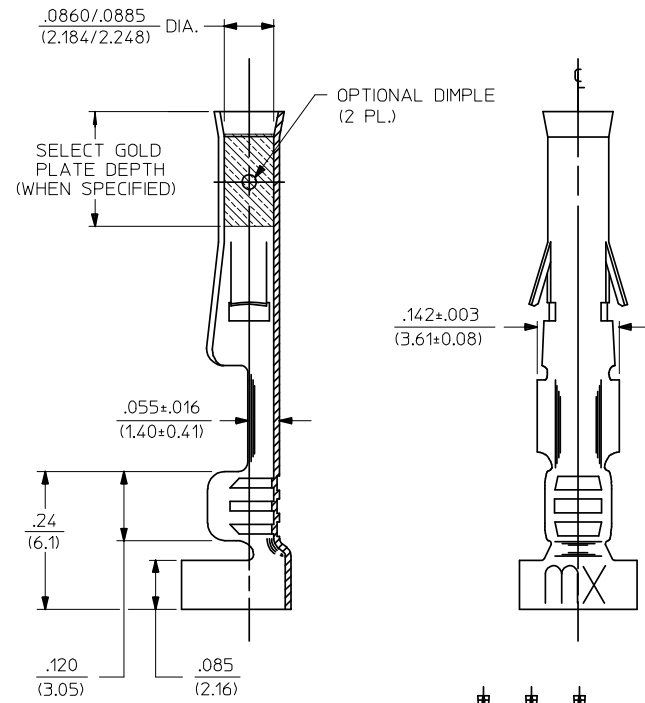
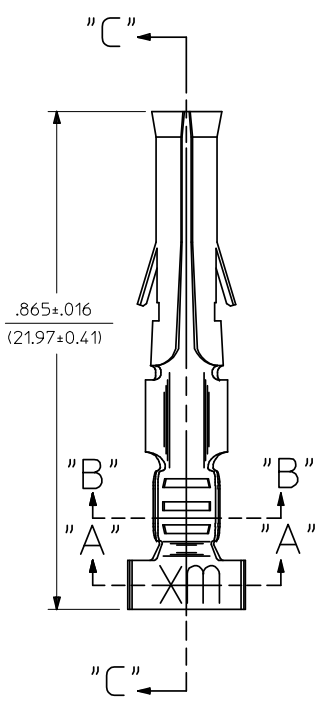
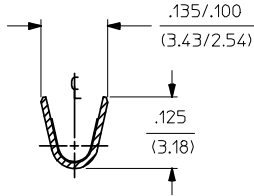
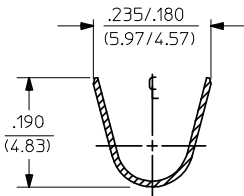
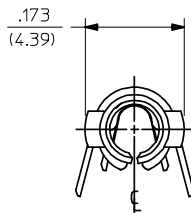

**LEGEND**

4550-\*(\*\*\*)\*  
 OPTIONAL DIMPLE  
 BLANK=WITH DIMPLE  
 A= WITHOUT DIMPLE  
 P=PREPLATE  
 BLANK=POSTPLATE  
 FORM  
 BLANK=CHAIN  
 L=LOOSE  
 FINISH CODE

**NOTES:**

1. MATERIAL: PHOSPHOR BRONZE
2. FINISHES:  
 901 - HOT TIN DIP .000020/(0.00051) MIN.  
 558 - SELECT GOLD PLATE .000030/(0.00076) MIN. IN CONTACT AREA, OVER .000050/(0.00127) MIN. NICKEL OVERALL WITH .000010/(0.00025) MAX. GOLD FLASH.
3. THIS PART CONFORMS TO PROD. SPEC. 02-09.
4. TERMINAL FOR USE WITH .093/(2.36) SERIES HOUSINGS AND WILL ACCEPT 14 THRU 20 AWG WIRE.
5. INSERTION FORCE: 3.5 LBS. MAX. WHEN TERMINAL IS INSERTED INTO AN .093 SERIES HOUSING.
6. RETENTION: 20 LBS. MIN. FROM HOUSING.

CORRECT DIMENSION EC NO: UCP2009-0419 DRAWING: GAVRILL 2008/08/18 CHKD: AELHAG 2008/08/19 APPR: FSM/TH 2008/08/20	QUALITY SYMBOLS ▽=0 ▽=0	GENERAL TOLERANCES (UNLESS SPECIFIED)		DIMENSION STYLE IN/MM		SCALE 6:1	DESIGN UNITS INCH	THIRD ANGLE PROJECTION		
		4 PLACES ± --- ± ---	DRAWN BY GWC	DATE 1991/05/02	TITLE CRIMP TERMINAL, FEMALE					
		3 PLACES ± --- ± .010	CHECKED BY RW	DATE 1991/05/02	MATERIAL NO. SEE CHART					
		2 PLACES ± 0.25 ± .014	APPROVED BY GWF	DATE 1991/05/02	DOCUMENT NO. SD-4550-*					
1 PLACE ± 0.35 ± ---	ANGULAR ± 1/2°		DRAFT WHERE APPLICABLE MUST REMAIN WITHIN DIMENSIONS		SIZE C		SHEET NO. 1 OF 1			
THIS DRAWING CONTAINS INFORMATION THAT IS PROPRIETARY TO MOLEX INCORPORATED AND SHOULD NOT BE USED WITHOUT WRITTEN PERMISSION										