

PLEASE CHECK WWW.MOLEX.COM FOR LATEST PART INFORMATION

Part Number: [0442626311](#)
Status: **Active**
Description: 5.33mm (.210") Pitch Crimp Terminal, Power Blade, Tin (Sn), All Over Nickel (Ni), 10-12 AWG, Blade Length 11.56mm (.455")

Documents:

[Drawing \(PDF\)](#) [RoHS Certificate of Compliance \(PDF\)](#)

General

Product Family	Crimp Terminals
Series	44262
Crimp Quality Equipment	Yes
Product Name	N/A

Physical

Durability (mating cycles max)	500
Gender	Male
Material - Metal	Copper
Material - Plating Mating	Tin
Packaging Type	Reel
Termination Interface: Style	Crimp or Compression
Wire Insulation Diameter	.79mm (.031") max.
Wire Size AWG	10, 12
Wire Size mm ²	N/A

Electrical

Current - Maximum per Contact	20A
Voltage - Maximum	600V AC

Material Info

Reference - Drawing Numbers

Sales Drawing	SD-44262-026
---------------	--------------

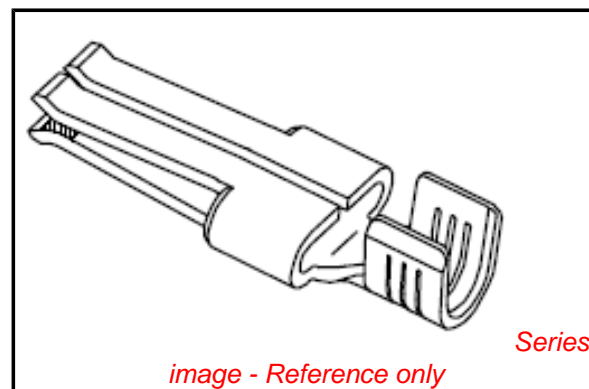

image - Reference only

EU RoHS

**ELV and RoHS
Compliant**

REACH SVHC

Contains SVHC: No

Halogen-Free

Status

Halogen-Free

China RoHS



**Need more information on product
environmental compliance?**

Email productcompliance@molex.com
 For a multiple part number RoHS Certificate of Compliance, [click here](#)

Please visit the [Contact Us](#) section for any non-product compliance questions.

Search Parts in this Series

[44262Series](#)

Use With

638326000 Crimp Applicator

Application Tooling | FAQ

Tooling specifications and manuals are found by selecting the products below. Crimp Height Specifications are then contained in the Application Tooling Specification document.

Global

Description	Product #
Hand Crimp Tool for 10, 12, 14 AWG Power Contact Terminals	0638195400
Mini-Mac™ Applicator	0638326000

PLEASE CHECK WWW.MOLEX.COM FOR LATEST PART INFORMATION

PART NUMBER	PLATING	RECOMMENDED WIRE SIZE	DIM 'A' BLADE LENGTH	DIM 'B' WIDTH	DIM 'C' HEIGHT	RECOMMENDED CRIMP APPLICATOR	PRODUCT STATUS
44262-6510	80-160μ INCHES TIN OVERALL OVER 50μ INCHES NICKEL OVERALL	8 AWG	10.03/.395	N/A	N/A	63832-6300	NOT TOOLED
44262-6511			11.56/.455				
44262-6512			13.08/.515				
44262-6520	30μ INCHES SELECT GOLD STRIPE OVER 50μ INCHES NICKEL OVERALL WITH 80-160μ INCHES SELECT TIN	(2) 12 AWG	10.03/.395	5.33+-.025 .210+-.010	5.97+-.050 .235+-.020	63832-6000	TOOLED
44262-6521			11.56/.455				
44262-6522			13.08/.515				
44262-6310			10.03/.395				
44262-6311	80-160μ INCHES TIN OVERALL OVER 50μ INCHES NICKEL OVERALL	10-12 AWG	11.56/.455	5.33+-.025 .210+-.010	5.97+-.050 .235+-.020	63832-6000	TOOLED
44262-6312			13.08/.515				
44262-6320			10.03/.395				
44262-6321	30μ INCHES SELECT GOLD STRIPE OVER 50μ INCHES NICKEL OVERALL WITH 80-160μ INCHES SELECT TIN	(2) 14 AWG	11.56/.455	5.33+-.025 .210+-.010	5.97+-.050 .235+-.020	63832-6000	TOOLED
44262-6322			13.08/.515				
44262-6410			10.03/.395				
44262-6411	80-160μ INCHES TIN OVERALL OVER 50μ INCHES NICKEL OVERALL	14-16 AWG	11.56/.455	5.33+-.025 .210+-.010	5.21+-.050 .205+-.020	63832-6100	TOOLED
44262-6412			13.08/.515				
44262-6420	30μ INCHES SELECT GOLD STRIPE OVER 50μ INCHES NICKEL OVERALL WITH 80-160μ INCHES SELECT TIN	(2) 16 AWG	10.03/.395	5.33+-.025 .210+-.010	5.21+-.050 .205+-.020	63832-6100	TOOLED
44262-6421			11.56/.455				
44262-6422			13.08/.515				

- NOTES:
- MATERIAL: COPPER ALLOY .032 IN THICK
 - FINISH: PER MOLEX PLATING SPECIFICATION ES-88 - SEE CHART
 - SEE CHART FOR CRIMP APPLICATOR NUMBER
 - FOR CRIMP TOOLING CONTACT MOLEX OR VISIT THE MOLEX WEBSITE AT WWW.MOLEX.COM
 - STD PACKAGE SIZE: 2,500 PARTS/REEL
 - SEE PRODUCT SPECIFICATION: PS-44262-001 FOR MORE INFORMATION.
 - PARTS ARE RgHS COMPLIANT
 - THIS PART MATES WITH RECEPTACLE (FEMALE) POWER CONTACT 44262-43** (SEE SD-44262-100)
 - FOR CRIMP SET UP INFORMATION SEE MOLEX APPLICATION DOCUMENT:
 - 8 AWG - ATS-638326300
 - 10/12 AWG - ATS-638326000
 - 14/16 AWG - ATS-638326100

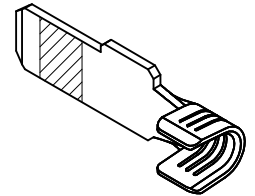

Ⓢ

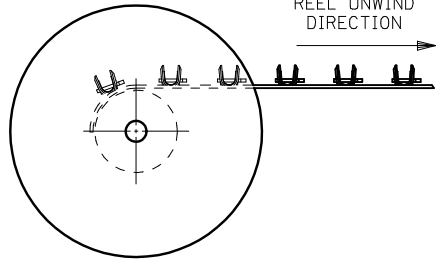
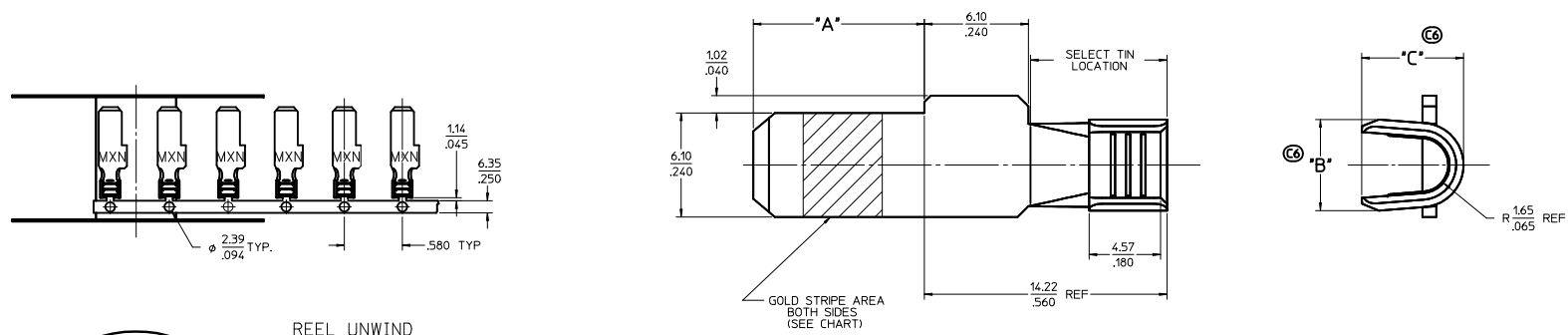

REV DIMS & CHART IEC NO: 2010/01/06 CHYK: APPR:	QUALITY SYMBOLS	GENERAL TOLERANCES (UNLESS SPECIFIED)	DIMENSION STYLE	SCALE	DESIGN UNITS	THIRD ANGLE PROJECTION
	▽=0	4 PLACES ±.010 ±.010	MM/IN	5:1	INCH	Ⓢ
	▽=0	3 PLACES ±.025 ±.010				
	▽=0	2 PLACES ±0.25 ±.010				
		1 PLACE ±0.25 ±.010				
		ANGULAR ±1/2°				
		DRAFT WHERE APPLICABLE MUST REMAIN WITHIN DIMENSIONS				
			MATERIAL NO.	DOCUMENT NO.		
			SEE CHART	SD-44262-026		