

PLEASE CHECK WWW.MOLEX.COM FOR LATEST PART INFORMATION

Part Number: [0442626321](#)
Status: **Active**
Description: 5.33mm (.210") Pitch Crimp Terminal, Power Blade, Select Gold Strips over Tin (Sn) Over Nickel (Ni), 10-12 AWG, Blade Length 11.56mm (.455")

Documents:

[Drawing \(PDF\)](#) [RoHS Certificate of Compliance \(PDF\)](#)

General

| | |
|-------------------------|-----------------------|
| Product Family | Crimp Terminals |
| Series | 44262 |
| Crimp Quality Equipment | Yes |
| Product Name | N/A |

Physical

| | |
|--------------------------------|----------------------|
| Durability (mating cycles max) | 500 |
| Gender | Male |
| Material - Metal | Copper |
| Material - Plating Mating | Gold |
| Packaging Type | Reel |
| Termination Interface: Style | Crimp or Compression |
| Wire Insulation Diameter | .79mm (.031") max. |
| Wire Size AWG | 10, 12 |
| Wire Size mm ² | N/A |

Electrical

| | |
|-------------------------------|---------|
| Current - Maximum per Contact | 20A |
| Voltage - Maximum | 600V AC |

Material Info

Reference - Drawing Numbers

| | |
|---------------|--------------|
| Sales Drawing | SD-44262-026 |
|---------------|--------------|

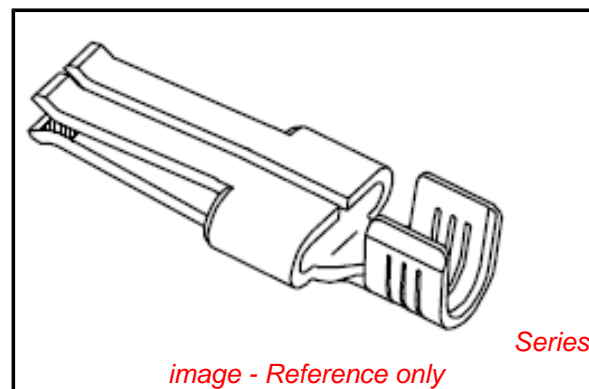

image - Reference only

EU RoHS

**ELV and RoHS
Compliant**

REACH SVHC

Contains SVHC: No

Halogen-Free

Status

Not Reviewed

China RoHS



**Need more information on product
environmental compliance?**

Email productcompliance@molex.com
 For a multiple part number RoHS Certificate of Compliance, [click here](#)

Please visit the [Contact Us](#) section for any non-product compliance questions.

Search Parts in this Series

[44262Series](#)

Use With

638326000 Crimp Applicator

Application Tooling | FAQ

Tooling specifications and manuals are found by selecting the products below. Crimp Height Specifications are then contained in the Application Tooling Specification document.

Global

| Description | Product # |
|--|----------------------------|
| Hand Crimp Tool for 10, 12, 14 AWG Power Contact Terminals | 0638195400 |
| Mini-Mac™ Applicator | 0638326000 |

PLEASE CHECK WWW.MOLEX.COM FOR LATEST PART INFORMATION

| PART NUMBER | PLATING | RECOMMENDED WIRE SIZE | DIM 'A' BLADE LENGTH | DIM 'B' WIDTH | DIM 'C' HEIGHT | RECOMMENDED CRIMP APPLICATOR | PRODUCT STATUS |
|-------------|---|-----------------------|----------------------|--------------------------|--------------------------|------------------------------|----------------|
| 44262-6510 | 80-160μ INCHES TIN OVERALL OVER 50μ INCHES NICKEL OVERALL | 8 AWG | 10.03/.395 | N/A | N/A | 63832-6300 | NOT TOOLED |
| 44262-6511 | | | 11.56/.455 | | | | |
| 44262-6512 | | | 13.08/.515 | | | | |
| 44262-6520 | 30μ INCHES SELECT GOLD STRIPE OVER 50μ INCHES NICKEL OVERALL WITH 80-160μ INCHES SELECT TIN | (2) 12 AWG | 10.03/.395 | N/A | N/A | 63832-6300 | NOT TOOLED |
| 44262-6521 | | | 11.56/.455 | | | | |
| 44262-6522 | | | 13.08/.515 | | | | |
| 44262-6310 | | | 10.03/.395 | | | | |
| 44262-6311 | 80-160μ INCHES TIN OVERALL OVER 50μ INCHES NICKEL OVERALL | 10-12 AWG | 11.56/.455 | N/A | N/A | 63832-6000 | NOT TOOLED |
| 44262-6312 | | | 13.08/.515 | | | | |
| 44262-6320 | | | 10.03/.395 | | | | |
| 44262-6321 | 30μ INCHES SELECT GOLD STRIPE OVER 50μ INCHES NICKEL OVERALL WITH 80-160μ INCHES SELECT TIN | (2) 14 AWG | 11.56/.455 | 5.33+-.025 .210+-.010 | 5.97+-.050 .235+-.020 | 63832-6000 | TOOLED |
| 44262-6322 | | | 13.08/.515 | | | | |
| 44262-6410 | | | 10.03/.395 | | | | |
| 44262-6411 | 80-160μ INCHES TIN OVERALL OVER 50μ INCHES NICKEL OVERALL | 14-16 AWG | 11.56/.455 | N/A | N/A | 63832-6100 | TOOLED |
| 44262-6412 | | | 13.08/.515 | | | | |
| 44262-6420 | 30μ INCHES SELECT GOLD STRIPE OVER 50μ INCHES NICKEL OVERALL WITH 80-160μ INCHES SELECT TIN | (2) 16 AWG | 10.03/.395 | N/A | N/A | 63832-6100 | TOOLED |
| 44262-6421 | | | 11.56/.455 | | | | |
| 44262-6422 | | | 13.08/.515 | | | | |

- NOTES:
- MATERIAL: COPPER ALLOY .032 IN THICK
 - FINISH: PER MOLEX PLATING SPECIFICATION ES-88 - SEE CHART
 - SEE CHART FOR CRIMP APPLICATOR NUMBER
 - FOR CRIMP TOOLING CONTACT MOLEX OR VISIT THE MOLEX WEBSITE AT WWW.MOLEX.COM
 - STD PACKAGE SIZE: 2,500 PARTS/REEL
 - SEE PRODUCT SPECIFICATION: PS-44262-001 FOR MORE INFORMATION.
 - PARTS ARE RgHS COMPLIANT
 - THIS PART MATES WITH RECEPTACLE (FEMALE) POWER CONTACT 44262-43** (SEE SD-44262-100)
 - FOR CRIMP SET UP INFORMATION SEE MOLEX APPLICATION DOCUMENT:
 - 8 AWG - ATS-638326300
 - 10/12 AWG - ATS-638326000
 - 14/16 AWG - ATS-638326100

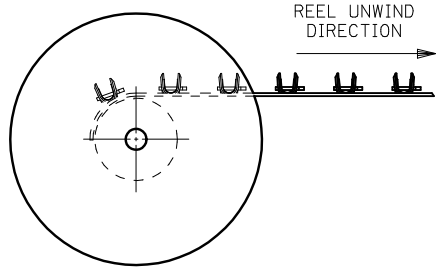
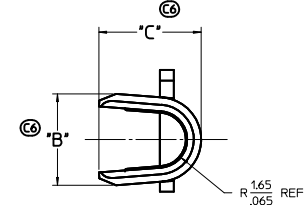
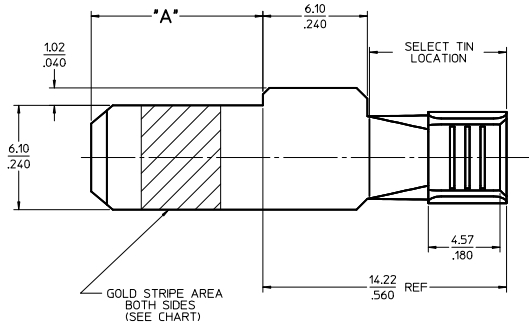
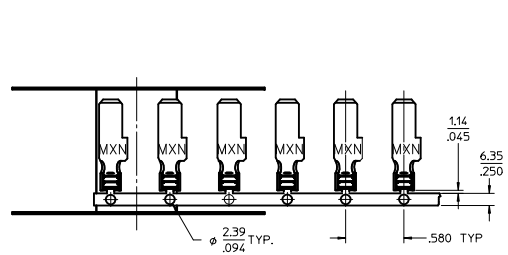
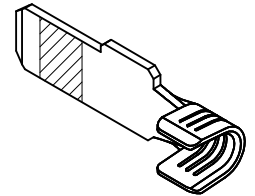

Ⓢ

Ⓢ

Ⓢ

| | | | | | | |
|---|-----------------|--|-----------------|--------------|--------------|------------------------|
| REV DIMS & CHART IEC NO: 2010/01/06 CHYK: APPR: | QUALITY SYMBOLS | GENERAL TOLERANCES (UNLESS SPECIFIED) | DIMENSION STYLE | SCALE | DESIGN UNITS | THIRD ANGLE PROJECTION |
| | ▽=0 | 4 PLACES ± .010 ± .010 | MM/IN | 5:1 | INCH | Ⓢ |
| | ▽=0 | 3 PLACES ± .025 ± .010 | | | | |
| | ▽=0 | 2 PLACES ± 0.25 ± .010 | | | | |
| | | 1 PLACE ± 0.25 ± .010 | | | | |
| | | ANGULAR ±1/2° | | | | |
| | | DRAFT WHERE APPLICABLE MUST REMAIN WITHIN DIMENSIONS | | | | |
| | | | MATERIAL NO. | DOCUMENT NO. | | |
| | | | SEE CHART | SD-44262-026 | | |
| | | | | | | |
| | | | | | | |

TERMINAL - BLADE POWER TERMINAL

MOLEX INCORPORATED

SD-44262-026 1 OF 1