



ADJUSTABLE FRICTION CLUTCHES

Huco Vari-Tork are rotary friction devices with adjustable drag or slip torque. Controlled slip takes place between the hub and housing whenever the load exceeds the set torque.

Hub to shaft connection is greatly simplified by the new clamp fastening styles.

- **2-plate & 6-plate models**
- **5 interface styles**
- **Set screw or clamp connection**
- **Compact proportions**
- **Use as a torque limiter, tensioning, or overrun device**

The construction is simple and robust and comprises a series of steel clutch plates engaging a hub and a series of friction rings engaging a housing. Pressure is brought to bear on the plates and friction rings by an adjuster acting through a spring and pressure plate. The load can be connected to either the steel inner hub or the aluminium alloy housing.

As a torque limiter, Vari-Tork interrupts continuity between power source and load when this reaches a pre-determined level.

As a tensioning device, Vari-Tork typically maintains tension in a filament or tape winding operation by exerting drag on the feed spool.

As an overrun device, Vari-Tork absorbs residual inertia of a motor when the load is braked or reaches a terminal stop.

NEW
CLAMP STYLE

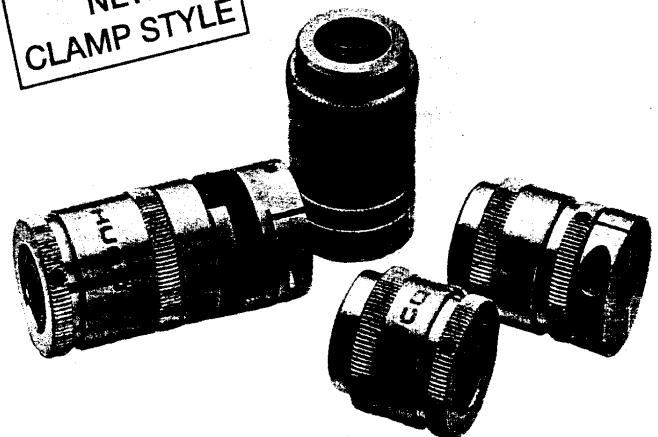

VARI-TORK ADJUSTABLE FRICTION CLUTCHES

Set screw hub at B1

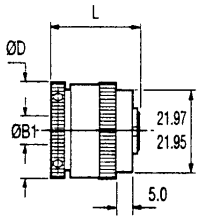

Ref. 271 (2 plate)
279 (6 plate)
Basic clutch
(thro' bore)

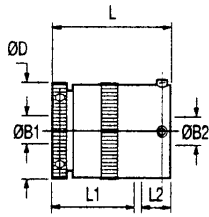

Ref. 273 (2 plate)
281 (6 plate)
Basic clutch
+ sleeve adaptor

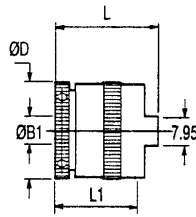

Ref. 275 (2 plate)
283 (6 plate)
Basic clutch
+ Oldham adaptor

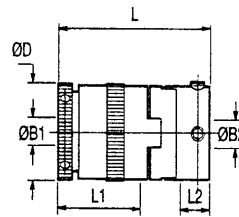

Ref. 277 (2 plate)
285 (6 plate)
Basic clutch
+ Oldham (set screw) coupler

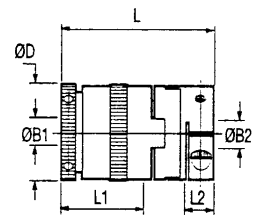

Ref. 267 (2 plate)
269 (6 plate)
Basic clutch
+ Oldham (clamp) coupler

Clamp hub at B1

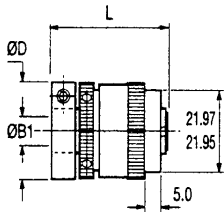

Ref. 401 (2 plate)
409 (6 plate)
Basic clutch
(thro' bore)

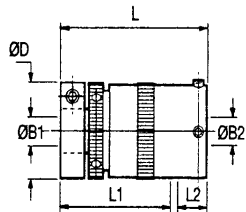

Ref. 403 (2 plate)
411 (6 plate)
Basic clutch
+ sleeve adaptor

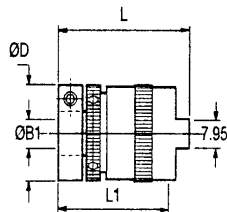

Ref. 405 (2 plate)
413 (6 plate)
Basic clutch
+ Oldham adaptor

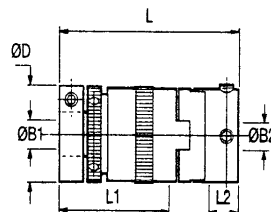

Ref. 407 (2 plate)
415 (6 plate)
Basic clutch
+ Oldham (set screw) coupler

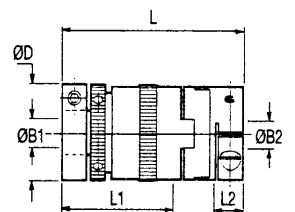

Ref. 397 (2 plate)
399 (6 plate)
Basic clutch
+ Oldham (clamp) coupler

Construction

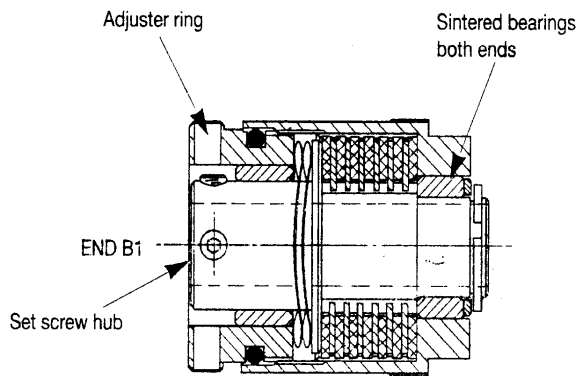

Sectional view of 6-plate Vari-Tork Ref. 279. Shafts are secured by set screws accessed through radial holes in the adjuster ring.

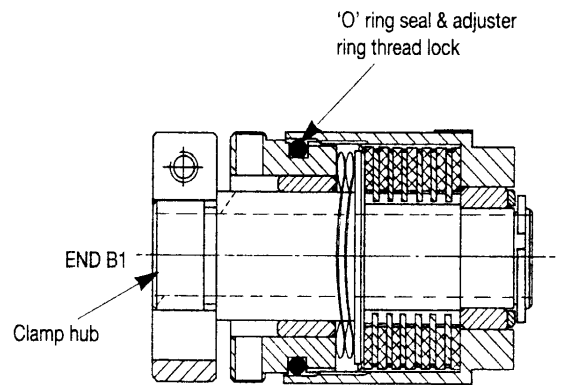

Sectional view of 6-plate Vari-Tork Ref. 409. Shafts are secured by a split hub and ring clamp method which does not score the shafts.

HOW TO ORDER

Combine the CLUTCH REF in Main Table with BORE REFS in Standard Bores Table. Please identify bores in ØB1, ØB2 sequence where 2 bores are shown, e.g.

273.25.2832

Clutch ref. _____

Ø B1 ref. _____

Ø B2 ref. _____

HOW TO INSTALL

Correct installation is important for optimum operation. See page 28 for details.

VARI-TORK ADJUSTABLE FRICTION CLUTCHES

MAIN TABLE - DIMENSIONS & ORDER CODES

Model	Set Screw Hub	Clamp Hub	ØD	L	¹ L1	² L2	ØB1 max	Fasteners at B1 end			ØB2 max	Fasteners at B2 end			Max drag torque Nm	³ Moment of inertia kgm ² x 10 ⁻⁸	³ Mass kg x 10 ⁻³
								Screw	² Torque Nm	Wrench mm		Screw	² Torque Nm	Wrench mm			
	CLUTCH REF																
2-PLATE	267.25	-	25.8	46.5	25.0	8.6	8	M3	0.94	1.5	12	M3	2.43	2.5	0.53	416	58
	271.25	-		26.4	thro'	-					-	-	-	242		37	
	273.25	-		36.0	25.0	9.0					12	M4	2.27	2		382	50
	275.25	-		31.6	25.0	-					-	-	-	288		42	
	277.25	-	46.5	25.0	8.6	12	M4	2.27	2	425	58						
	-	397.25	25.8	54.5	33.0	8.6	8	M3	2.43	2.5	12	M3	2.43	2.5	0.53	508	68
	-	401.25		34.4	thro'	-					-	-	-	317		47	
	-	403.25		44.0	33.0	9.0					12	M4	2.27	2		441	60
-	405.25	39.6		33.0	-	-					-	-	361	52			
-	407.25	54.5	33.0	8.6	12	M4	2.27	2	511	69							
6-PLATE	269.25	-	25.8	53.4	31.0	8.6	8	M3	0.94	1.5	12	M3	2.43	2.5	1.32	529	68
	279.25	-		32.4	thro'	-					-	-	-	312		48	
	281.25	-		42.5	31.0	9.0					12	M4	2.27	2		451	60
	283.25	-		37.2	31.0	-					-	-	-	383		53	
	285.25	-	53.4	31.0	8.6	12	M4	2.27	2	516	69						
	-	399.25	25.8	60.8	39.0	8.6	8	M3	2.43	2.5	12	M3	2.43	2.5	1.32	617	79
	-	409.25		40.7	thro'	-					-	-	-	381		58	
	-	411.25		50.3	39.0	9.0					12	M4	2.27	2		530	71
-	413.25	45.9		39.0	-	-					-	-	433	63			
-	415.25	60.8	39.0	8.6	12	M4	2.27	2	590	80							

1. Max. shaft penetration
2. Recommended tightening torque.
3. Values apply with max bores.

DATA

Power dissipation at 20°C	7 watts (2-plate models)
	8.6 watts (6-plate models)
Backlash	2° max (all models)
Max permissible surface temperature	80°C (all models)
Max sustained slipping speed	1000 rpm

STANDARD BORES

	ØB1, ØB2 +0.03/-0mm						
	6	6.350	7.938	8	9.525	10	12
At B1 end	●	●	●	●			
At B2 end	●	●	●	●	●	●	●
Bore ref.	22	24	27	28	31	32	35
Corresponding bore adaptor		253		255		257	

Diameters for which a bore adaptor is shown can be adapted to smaller shaft sizes. See page 32 for details.

How to install Vari-Tork

BASIC CLUTCH - REFS. 271, 279, 401 & 409

Controlled slip occurs between pulley and shaft.

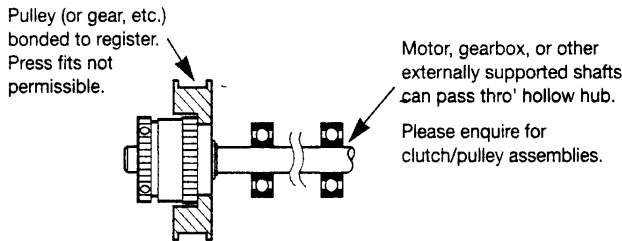

BASIC CLUTCH + SLEEVE ADAPTOR - REFS. 273, 281, 403 & 411

Controlled slip occurs between LH & RH shafts. Clutch orientation not important, supported shaft may be entered either end.

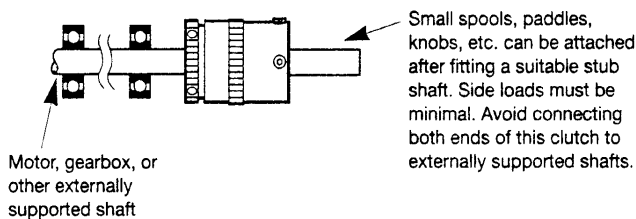

BASIC CLUTCH + FLEXIBLE COUPLER - REFS. 267, 269, 277, 285, 397, 399, 407 & 415

Controlled slip occurs between LH & RH shafts.

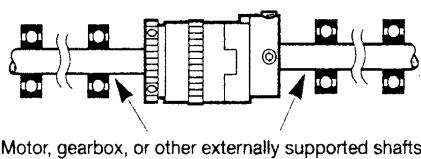

Vari-Tork characteristics

The characteristics of dry plate clutches favour those applications which can tolerate relatively imprecise drag torques. Three tendencies should be noted:

BREAKAWAY TORQUE

After a period during which no slipping has taken place, the breakaway torque can be up to 2 1/2 times the set value.

TORQUE DECAY

There is an inverse relationship between clutch temperature and slipping torque. The slipping torque reduces from the set value as the power being dissipated causes the clutch temperature to rise. When slipping continuously, torque settles at approximately 70% of the value set on a new clutch and at approximately 80% of the value set on a used clutch. This characteristic is not speed-dependent.

SPEED RELATED TORQUE FLUCTUATIONS

Variations in slipping speed cause a momentary increase in the prevailing output torque. The clutches behave more consistently at high speed/low torque than at low speed/high torque. High speed in this instance starts at approximately 500 rpm.

Where applications call for sustained slipping, the housing temperature should be maintained below 80°C. Clutches mounted concentrically within pulleys, gear wheels, etc. will be more effective at dissipating heat generated during slipping.

CALCULATING FOR POWER DISSIPATION

Given the slipping speed in rpm and the drag torque in Nm, the following equation can be used for calculating the power dissipation in watts (W).

$$W = \frac{Nm \cdot rpm}{9.55}$$

Locking ring

In some circumstances it is possible for the adjuster ring to unscrew during operation. The adjuster ring can be secured by fitting locking ring ref. 294.25.

Removing the adjuster ring

- 1) If this should be necessary, be sure to replace the pressure plate first, then the spring washers. Ensure that the topmost friction ring is fully engaged with the splines. **A disengaged friction ring will cause the clutch to malfunction.**
- 2) To remove the adjuster ring, first remove the clamp. With set screw hubs the adjuster ring cannot be removed if the set screws protrude above the hub diameter. Flattening or dimpling of shafts is recommended and may be necessary with shafts larger than Ø6.35 to avoid the screws fouling the adjuster ring.

Waved washers

Two waved washers are fitted to these clutches. In some instances, better torque control may result from removing one of them, particularly when working in the lower torque ranges.

Locking ring

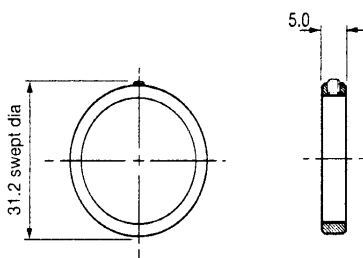

order ref.

294.25

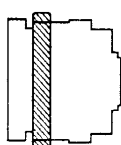

Fit locking ring flush with end of housing as shown. Lightly tension locking screw to secure the adjuster. Wrench size 1.5

mix 'n match

Components in the Vari-Tork 25 series can be specified individually. This facility, together with a small inventory of parts, allows any permutation of bores to be assembled in-house at short notice.

The elements are identified below in exploded form and tabulated under their respective order codes. Huco-Lok bore reducers provide the means for further increasing the bore diameter options.

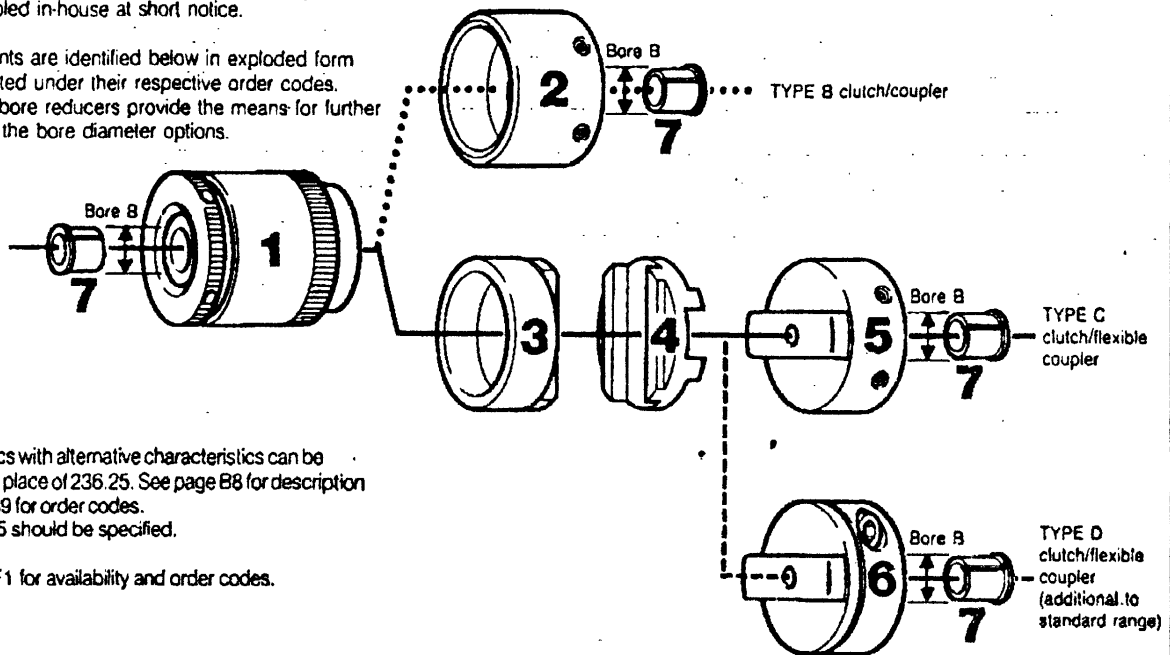

* Torque discs with alternative characteristics can be specified in place of 236.25. See page B8 for description and page B9 for order codes. Only size 25 should be specified.

† See page F1 for availability and order codes.

bores & order codes

Bores B	1		2	3	4	5	6	7
	Type A 2 plate clutch Order Code	Type A 6 plate clutch Order Code	Muff Adaptor Order Code	Coupler Adaptor Order Code	* Torque Disc Order Code	Set Screw Hub Order Code	Clamp Hub Order Code	† Bore reducer outlines corresponding with Bores B
	M3 screws	M3 screws	M4 screws	—	—	M4 screws	M3 screws	
6 00	271.25.22	279.25.22	287.25.22	289.25	236.25	232.25.22	234.25.22	—
6 35	271.25.24	279.25.24	287.25.24	289.25	236.25	232.25.24	234.25.24	253
7 94	271.25.27	279.25.27	287.25.27	289.25	236.25	232.25.27	234.25.27	—
8 00	271.25.28	279.25.28	287.25.28	289.25	236.25	232.25.28	234.25.28	255
9 53	—	—	287.25.31	289.25	236.25	232.25.31	234.25.31	—
10 00	—	—	287.25.32	289.25	236.25	232.25.32	234.25.32	257
	6-32 screws	6-32 screws	8-32 screws	—	—	8-32 screws	6-32 screws	
6 35	272.25.24	280.25.24	288.25.24	289.25	236.25	233.25.24	235.25.24	253
7 94	272.25.27	280.25.27	288.25.27	289.25	236.25	233.25.27	235.25.27	—
9 53	—	—	288.25.31	289.25	236.25	233.25.31	235.25.31	—

assembly

Loctite® 638 is suitable for bonding together elements 1 and 2 or 1 and 3 (observing the maker's recommendations). An arbor, sized to correspond with the bores in elements 1 and 2 is recommended in order to maintain concentricity during the bonding operation. Elements 4, 5 and 6 are identical with components listed under Oldham Misalignment Couplers on Pages B9 and B10

Loctite is a registered trademark.

to order

The components can be supplied factory assembled for a nominal charge. Please indicate clearly those items which are to be assembled and group them in matched quantities, e.g.

5 qty 271.25.24 assembled	15 qty 271.25.24 loose
5 qty 287.25.32 assembled	15 qty 287.25.32 loose
5 qty 271.25.24 assembled	5 qty 289.25 loose
5 qty 289.25 assembled	OR 5 qty 236.25 loose
5 qty 236.25 assembled	5 qty 232.25.32 loose
5 qty 232.25.32 assembled	5 qty 257.20 loose
5 qty 257.20 assembled	
5 qty 271.25.24 loose	
10 qty 287.25.32 loose	