

Features

- Powerful Harvard-architecture processor
 - M8C processor speeds to 12 MHz
 - Low power at high speed
 - 2.4 V to 3.6 V operating voltage
 - Operating voltages down to 1.0 V using on-chip switch mode pump (SMP)
 - Commercial temperature range: 0 °C to +70 °C
- Configurable peripherals
 - 8-bit timers, counters, and PWM
 - Full duplex master or slave SPI
 - 10-bit ADC
 - 8-bit successive approximation ADC
 - Comparator
- Flexible on-chip memory
 - 8K flash program storage 50,000 erase/write cycles
 - 512 bytes SRAM data storage
 - In-System serial programming (ISSP)
 - Partial flash updates
 - Flexible protection modes
 - EEPROM emulation in flash
- Complete development tools
 - Free development software (PSoC Designer™)
 - Full-featured, In-circuit emulator and programmer
 - Complex breakpoint structure
 - 128K trace memory
- Precision, programmable clocking
 - Internal ±2.5% 24 and 48 MHz oscillator
 - Internal oscillator for watchdog and sleep
- Programmable pin configurations
 - 10 mA drive on all general purpose IO (GPIO)
 - Pull-up, pull-down, high-Z, strong, or open drain drive modes on all GPIO
 - Up to 8 analog inputs on GPIO
 - Configurable interrupt on all GPIO
- Versatile analog mux
 - Common internal analog bus
 - Simultaneous connection of IO combinations
- Additional system resources
 - I²C master, slave, and Multimaster to 400 kHz
 - Watchdog and sleep timers
 - User-configurable low-voltage detection
 - Integrated supervisory circuit
 - On-chip precision voltage reference

Applications

- Wireless mice
- Wireless gamepads
- Wireless presenter tools
- Wireless keypads
- PlayStation® 2 wired gamepads
- PlayStation 2 bridges for wireless gamepads
 - Applications requiring a cost effective low voltage 8-bit microcontroller.

Logic Block Diagram

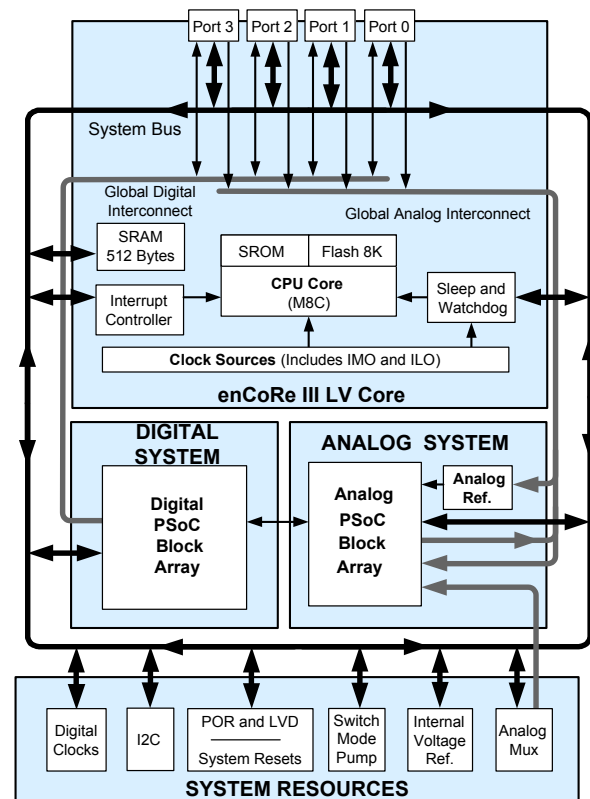

Contents

enCoRe III Low Voltage Functional Overview	3	Electrical Specifications	15
enCoRe III LV Core	3	Absolute Maximum Ratings	16
The Digital System	3	Operating Temperature	16
The Analog System	3	DC Electrical Characteristics	17
Additional System Resources	4	AC Electrical Characteristics	22
enCoRe III LV Device Characteristics	4	Packaging Information	28
Getting Started	4	Packaging Dimensions	28
Development Kits	4	Thermal Impedances	30
Development Tools	5	Solder Reflow Peak Temperature	30
PSoC Designer Software Subsystems	5	Ordering Information	31
In-Circuit Emulator	5	Ordering Code Definitions	31
Designing with PSoC Designer	6	Acronyms	32
Select Components	6	Acronyms Used	32
Configure Components	6	Reference Documents	32
Organize and Connect	6	Document Conventions	33
Generate, Verify, and Debug	6	Units of Measure	33
Pin Information	7	Numeric Conventions	33
28-pin Part Pinout	7	Glossary	33
32-pin Part Pinout	8	Document History Page	38
Register Reference	11	Sales, Solutions, and Legal Information	39
Register Conventions	11	Worldwide Sales and Design Support	39
Register Mapping Tables	11	Products	39
		PSoC® Solutions	39

enCoRe III Low Voltage Functional Overview

The enCoRe III low voltage (enCoRe III LV) CY7C603xx device is based on the flexible PSoC[®] architecture. This supports a simple set of peripherals that can be configured to match the needs of each application. Additionally, a fast CPU, flash program memory, SRAM data memory, and configurable IO are included in a range of convenient pinouts.

This architecture enables the user to create customized peripheral configurations that match the requirements of each individual application. A fast CPU, flash program memory, SRAM data memory, and configurable IO are included in both 28-pin SSOP and 32-pin QFN packages.

The enCoRe III LV architecture, as shown in Figure 1, consists of four main areas: the enCoRe III LV Core, the system resources, digital system, and analog system. Configurable global bus resources allow combining all the device resources into a complete custom system. Each enCoRe III LV device supports a limited set of digital and analog peripherals. Depending on the package, up to 28 general purpose IOs (GPIOs) are also included. The GPIOs provide access to the global digital and analog interconnects.

enCoRe III LV Core

The enCoRe III LV core is a powerful engine that supports a rich feature set. It encompasses SRAM for data storage, an interrupt controller, sleep and watchdog timers, and IMO (internal main oscillator) and ILO (internal low-speed oscillator).

The CPU core, called the M8C, is a powerful processor with speeds up to 12 MHz. The M8C is a four MIPS 8-bit Harvard -architecture microprocessor. The core includes a CPU, memory, clocks, and configurable GPIO (General Purpose IO).

System resources provide additional capability, such as digital clocks to increase flexibility, I²C functionality for implementing an I²C master, slave, multi-master, an internal voltage reference that provides an absolute value of 1.3 V to a number of subsystems, a switch mode pump (SMP) that generates normal operating voltages off a single battery cell, and various system resets supported by the M8C.

The Digital System

The digital system consists of 4 digital enCoRe III LV blocks. Each block is an 8-bit resource. Digital peripheral configurations include the following:

- PWM usable as timer or counter
- SPI master and slave
- I2C slave and multi-master
- CMP
- ADC10
- SARADC

Figure 1. Digital System Block Diagram

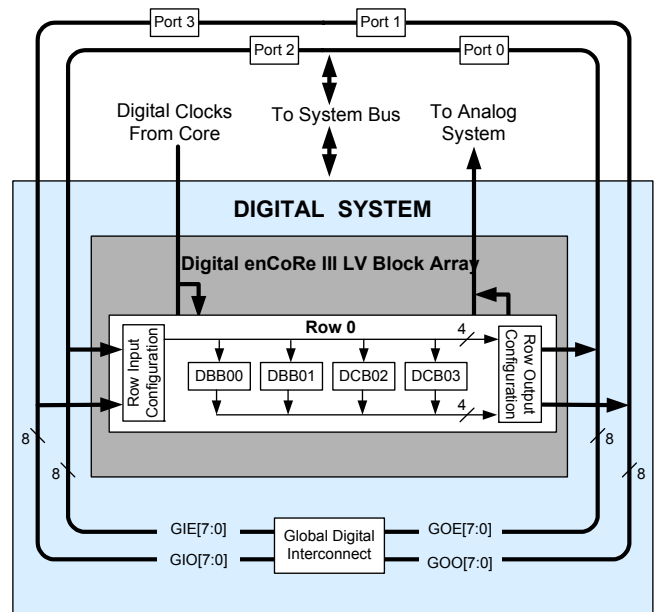

The digital blocks may be connected to any GPIO through a series of global buses that can route any signal to any pin. The buses also allow for signal multiplexing and for performing logic operations. This configurability frees your designs from the constraints of a fixed peripheral controller.

The Analog System

The analog system consists of two configurable blocks. Analog peripherals are very flexible and may be customized to support specific application requirements. Some of the common analog functions for this device (available as user modules) are:

- Analog-to-digital converters (single with 8-bit resolution)
- Pin-to-pin comparators
- Single-ended comparators with absolute (1.3 V) reference
- 1.3 V reference (as a system resource)

Analog blocks are provided in columns of two, which includes one CT (continuous time - ACE00 or ACE01) and one SC (switched capacitor - ASE10 or ASE11) blocks.

Figure 2. Analog System Block Diagram

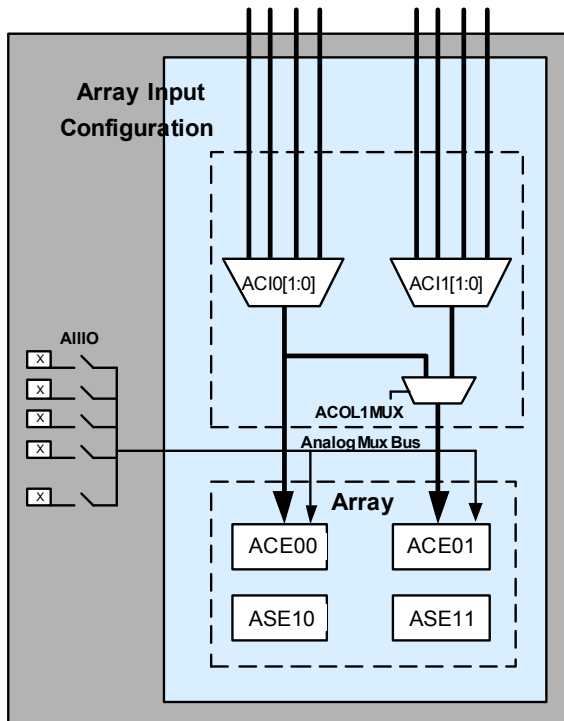

- The I²C module provides 100 kHz and 400 kHz communication over two wires. slave, master, and multi-master modes are all supported.
- Low voltage detection interrupts can signal the application of falling voltage levels, while the advanced POR circuit eliminates the need for a system supervisor.
- An internal 1.3 voltage reference provides an absolute reference for the analog system.
- An integrated switch mode pump generates normal operating voltages from a single 1.2 V battery cell, providing a low-cost boost converter.
- Versatile analog multiplexer system.

enCoRe III LV Device Characteristics

The enCoRe III LV devices have four digital blocks and four analog blocks. Table 1 lists the resources available for specific enCoRe III LV devices.

Table 1. enCoRe III LV Device Characteristics

Part Number	Digital IO	Digital Rows	Digital Blocks	Analog Inputs	Analog Outputs	Analog Columns	Analog Blocks	SRAM Size	Flash Size
CY7C60323-PVXC	24	1	4	24	0	2	4	512 Bytes	8K

Getting Started

The quickest path to understanding the enCoRe III LV silicon is by reading this data sheet and using the PSoC Designer integrated development environment (IDE). This data sheet is an overview of the enCoRe III LV and presents specific pin, register, and electrical specifications. enCoRe III LV is based on the architecture of the CY8C21x34. For in-depth information, along with detailed programming information, refer to the PSoC Programmable System-on-Chip Technical Reference Manual, which is available at <http://www.cypress.com>.

For up-to-date ordering, packaging, and electrical specification information, refer to the latest device data sheets on the web at <http://www.cypress.com>.

Development Kits

Development kits are available from the following distributors: Digi-key, avnet, arrow, and future. The Cypress online store contains development kits, C compilers, and all accessories for enCoRe III LV development. Go to the Cypress online store web site at <http://www.cypress.com>.

The Analog Multiplexer System

The analog mux bus can connect to every GPIO pin. Pins are connected to the bus individually or in any combination. The bus also connects to the analog system for analysis with comparators and analog-to-digital converters. An additional 8:1 analog input multiplexer provides a second path to bring Port 0 pins to the analog array.

Additional System Resources

System resources, some of which are listed in the previous sections, provide additional capability useful to complete systems. Additional resources include a switch mode pump, low voltage detection, and power on reset. Brief statements describing the merits of each system resource follow.

- Digital clock dividers provide three customizable clock frequencies for use in applications. The clocks can be routed to both the digital and analog systems. Additional clocks may be generated using digital blocks as clock dividers.

Development Tools

PSoC Designer is a Microsoft® Windows-based, integrated development environment for the Programmable System-on-Chip (PSoC) devices. The PSoC Designer IDE runs on Windows XP or Windows Vista.

This system provides design database management by project, an integrated debugger with In-circuit emulator, in-system programming support, and built-in support for third-party assemblers and C compilers.

PSoC Designer also supports C language compilers developed specifically for the devices in the PSoC family.

PSoC Designer Software Subsystems

System-Level View

A drag-and-drop visual embedded system design environment based on PSoC Express. In the system-level view you create a model of your system inputs, outputs, and communication interfaces. You define when and how an output device changes state based upon any or all other system devices. Based upon the design, PSoC Designer automatically selects one or more PSoC Mixed-Signal Controllers that match your system requirements.

PSoC Designer generates all embedded code, then compiles and links it into a programming file for a specific PSoC device.

Chip-Level View

The chip-level view is a more traditional integrated development environment (IDE). Choose a base device to work with and then select different onboard analog and digital components called user modules that use the PSoC blocks. Examples of user modules are ADCs, DACs, amplifiers, and filters. Configure the user modules for your chosen application and connect them to each other and to the proper pins. Then generate your project. This prepopulates your project with APIs and libraries that you can use to program your application.

The device editor also supports easy development of multiple configurations and dynamic reconfiguration. Dynamic configuration enables changing configurations at run time.

Hybrid Designs

You can begin in the system-level view, allow it to choose and configure your user modules and routing, and generate code. Then switch to the chip-level view to gain complete control over on-chip resources. All views of the project share a common code editor, builder, and common debug, emulation, and programming tools.

Code Generation Tools

PSoC Designer supports multiple third party C compilers and assemblers. The code generation tools work seamlessly within the PSoC Designer interface and have been tested with a full range of debugging tools. The choice is yours.

Assemblers. The assemblers enable assembly code to merge seamlessly with C code. Link libraries automatically use absolute addressing or are compiled in relative mode, and linked with other software modules to get absolute addressing.

C Language Compilers. C language compilers are available that support the PSoC family of devices. The products enable you to create complete C programs for the PSoC family devices.

The optimizing C compilers provide all the features of C tailored to the PSoC architecture. They come complete with embedded libraries providing port and bus operations, standard keypad and display support, and extended math functionality.

Debugger

The PSoC Designer Debugger subsystem provides hardware in-circuit emulation, allowing you to test the program in a physical system while providing an internal view of the PSoC device. Debugger commands enable the designer to read and program and read and write data memory, read and write I/O registers, read and write CPU registers, set and clear breakpoints, and provide program run, halt, and step control. The debugger also enables the designer to create a trace buffer of registers and memory locations of interest.

Online Help System

The online help system displays online, context-sensitive help for the user. Designed for procedural and quick reference, each functional subsystem has its own context-sensitive help. This system also provides tutorials and links to FAQs and an online support forum to aid the designer in getting started.

In-Circuit Emulator

A low-cost, high functionality In-circuit emulator (ICE) is available for development support. This hardware can program single devices.

The emulator consists of a base unit that connects to the PC by way of a USB port. The base unit is universal and operates with all PSoC devices. Emulation pods for each device family are available separately. The emulation pod takes the place of the PSoC device in the target board and performs full speed (24-MHz) operation.

Designing with PSoC Designer

The development process for the PSoC device differs from that of a traditional fixed function microprocessor. The configurable analog and digital hardware blocks give the PSoC architecture a unique flexibility that pays dividends in managing specification change during development and by lowering inventory costs. These configurable resources, called PSoC blocks, have the ability to implement a wide variety of user-selectable functions.

The PSoC development process can be summarized in the following four steps:

1. Select components
2. Configure components
3. Organize and connect
4. Generate, verify, and debug

Select Components

Both the system-level and chip-level views provide a library of prebuilt, pretested hardware peripheral components. In the system-level view, these components are called drivers and correspond to inputs (a thermistor, for example), outputs (a brushless DC fan, for example), communication interfaces (I²C-bus, for example), and the logic to control how they interact with one another (called valuator).

In the chip-level view, the components are called user modules. User modules make selecting and implementing peripheral devices simple, and come in analog, digital, and mixed signal varieties.

Configure Components

Each of the components you select establishes the basic register settings that implement the selected function. They also provide parameters and properties that enable you to tailor their precise configuration to your particular application. For example, a pulse width modulator (PWM) user module configures one or more digital PSoC blocks, one for each 8 bits of resolution. The user module parameters permit you to establish the pulse width and duty cycle. Configure the parameters and properties to correspond to your chosen application. Enter values directly or by selecting values from drop-down menus.

Both the system-level drivers and chip-level user modules are documented in datasheets that are viewed directly in PSoC Designer. These datasheets explain the internal operation of the component and provide performance specifications. Each datasheet describes the use of each user module parameter or driver property, and other information you may need to successfully implement your design.

Organize and Connect

You can build signal chains at the chip level by interconnecting user modules to each other and the I/O pins, or connect system level inputs, outputs, and communication interfaces to each other with valuator functions.

In the system-level view, selecting a potentiometer driver to control a variable speed fan driver and setting up the valuator to control the fan speed based on input from the pot selects, places, routes, and configures a programmable gain amplifier (PGA) to buffer the input from the potentiometer, an analog-to-digital converter (ADC) to convert the potentiometer's output to a digital signal, and a PWM to control the fan.

In the chip-level view, perform the selection, configuration, and routing so that you have complete control over the use of all on-chip resources.

Generate, Verify, and Debug

When you are ready to test the hardware configuration or move on to developing code for the project, perform the Generate Application step. This causes PSoC Designer to generate source code that automatically configures the device to your specification and provides the software for the system.

Both system-level and chip-level designs generate software based on your design. The chip-level design provides application programming interfaces (APIs) with high-level functions to control and respond to hardware events at run-time and interrupt service routines that you can adapt as needed. The system-level design also generates a C main() program that completely controls the chosen application and contains placeholders for custom code at strategic positions. This allows you to further refine the software without disrupting the generated code.

A complete code development environment allows you to develop and customize your applications in C, assembly language, or both.

The last step in the development process takes place inside PSoC Designer's debugger subsystem. The debugger downloads the HEX image to the ICE where it runs at full speed. Debugger capabilities rival those of systems costing many times more. In addition to traditional single-step, run-to-breakpoint and watch-variable features, the Debugger provides a large trace buffer and allows you define complex breakpoint events. These include monitoring address and data bus values, memory locations and external signals.

Pin Information

The enCoRe III LV device is available in 28-pin SSOP and 32-pin QFN packages. Every port pin (labeled with a “P”) is capable of Digital IO and connection to the common analog bus. However, Vss, Vdd, SMP, and XRES are not capable of Digital IO.

28-pin Part Pinout

Figure 3. CY7C60323-PVXC 28-pin Device

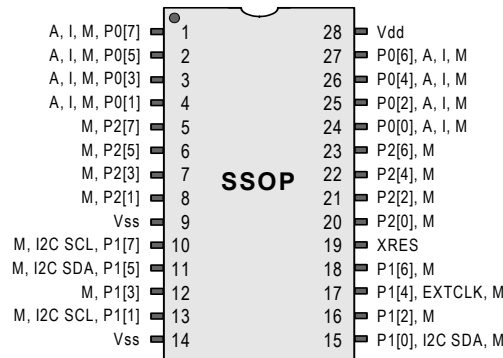

Table 2. Pin Definitions - CY7C60323-PVXC 28-pin Device

Pin No.	Type		Name	Description
	Digital	Analog		
1	IO	I, M	P0[7]	Analog column mux input.
2	IO	I, M	P0[5]	Analog column mux input and column output.
3	IO	I, M	P0[3]	Analog column mux input and column output, integrating input.
4	IO	I, M	P0[1]	Analog column mux input, integrating input.
5	IO	M	P2[7]	
6	IO	M	P2[5]	
7	IO	I, M	P2[3]	Direct switched capacitor block input.
8	IO	I, M	P2[1]	Direct switched capacitor block input.
9	Power		Vss	Ground connection.
10	IO	M	P1[7]	I ² C serial clock (SCL).
11	IO	M	P1[5]	I ² C serial data (SDA).
12	IO	M	P1[3]	
13	IO	M	P1[1]	I ² C serial clock (SCL), ISSP-SCLK.
14	Power		Vss	Ground connection.
15	IO	M	P1[0]	I ² C serial data (SDA), ISSP-SDATA.
16	IO	M	P1[2]	
17	IO	M	P1[4]	Optional external clock input (EXTCLK).
18	IO	M	P1[6]	
19	Input		XRES	Active HIGH external reset with internal pull down.
20	IO	I, M	P2[0]	Direct switched capacitor block input.
21	IO	I, M	P2[2]	Direct switched capacitor block input.
22	IO	M	P2[4]	
23	IO	M	P2[6]	
24	IO	I, M	P0[0]	Analog column mux input
25	IO	I, M	P0[2]	Analog column mux input
26	IO	I, M	P0[4]	Analog column mux input
27	IO	I, M	P0[6]	Analog column mux input
28	Power		Vdd	Supply voltage.

LEGEND A = analog, I = input, O = output, and M = analog mux input.

32-pin Part Pinout

Figure 4. CY7C60323-LFXC 32-pin Device

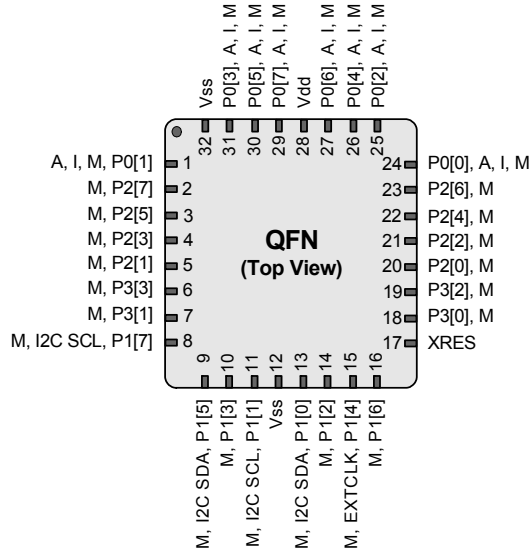

Figure 5. CY7C60333-LFXC 32-pin Device

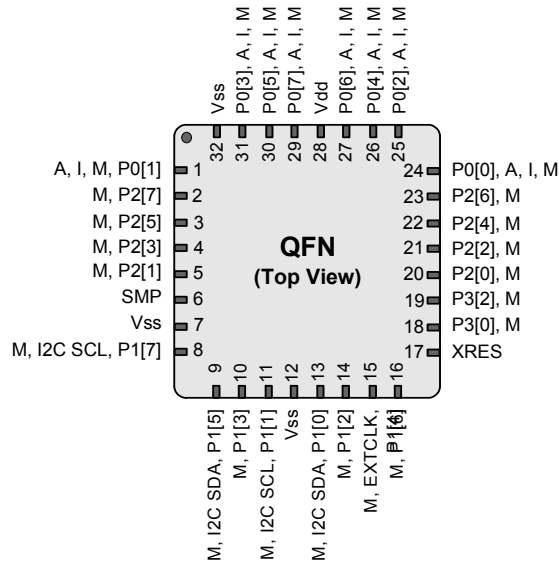

Figure 6. CY7C60323-LTXC 32-pin Device Sawn

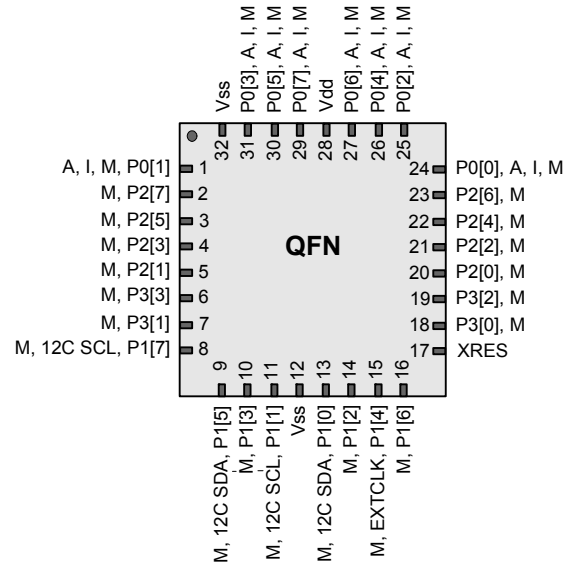

Figure 7. CY7C60333-LTXC 32-pin Device Sawn

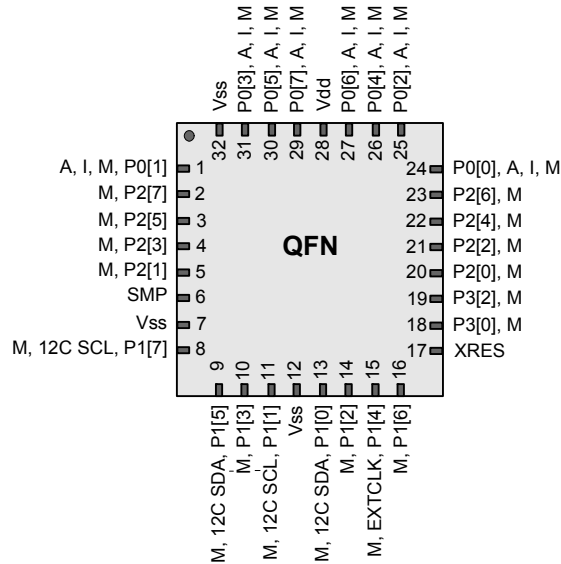

Table 3. 32-pin Part Pinout (QFN⁽¹⁾)

Pin No.	Type		Name	Description
	Digital	Analog		
1	IO	I, M	P0[1]	Analog column mux input, integrating input.
2	IO	M	P2[7]	
3	IO	M	P2[5]	
4	IO	M	P2[3]	
5	IO	M	P2[1]	
6	IO	M	P3[3]	In CY7C60323 part.
6	Power		SMP	Switch mode pump (SMP) connection to required external components in CY7C60333 part.
7	IO	M	P3[1]	In CY7C60323 Part.
7	Power		Vss	Ground connection in CY7C60333 part.
8	IO	M	P1[7]	I ² C serial clock (SCL).
9	IO	M	P1[5]	I ² C serial data (SDA).
10	IO	M	P1[3]	
11	IO	M	P1[1]	I ² C serial clock (SCL), ISSP-SCLK.
12	Power		Vss	Ground connection.
13	IO	M	P1[0]	I ² C serial data (SDA), ISSP-SDATA.
14	IO	M	P1[2]	
15	IO	M	P1[4]	Optional external clock input (EXTCLK).
16	IO	M	P1[6]	
17	Input		XRES	Active HIGH external reset with internal pull-down.
18	IO	M	P3[0]	
19	IO	M	P3[2]	
20	IO	M	P2[0]	
21	IO	M	P2[2]	
22	IO	M	P2[4]	
23	IO	M	P2[6]	
24	IO	I, M	P0[0]	Analog column mux input.
25	IO	I, M	P0[2]	Analog column mux input.
26	IO	I, M	P0[4]	Analog column mux input.
27	IO	I, M	P0[6]	Analog column mux input.
28	Power		Vdd	Supply voltage.
29	IO	I, M	P0[7]	Analog column mux input.
30	IO	I, M	P0[5]	Analog column mux input
31	IO	I, M	P0[3]	Analog column mux input, integrating input.
32	Power		Vss	Ground connection.

LEGEND A = analog, I = input, O = output, and M = analog mux input.

Note

1. The QFN package has a center pad that must be connected to ground (Vss).

Register Reference

This section lists the registers of the enCoRe III LV device. For detailed register information, refer the [PSoC System-on-Chip Technical Reference Manual](#).

Register Conventions

The register conventions specific to this section are listed in [Table 4](#).

Table 4. Register Conventions

Convention	Description
R	Read register or bit(s)
W	Write register or bit(s)
L	Logical register or bit(s)
C	Clearable register or bit(s)
#	Access is bit specific

Register Mapping Tables

The enCoRe III LV device has a total register address space of 512 bytes. The register space is referred to as IO space and is divided into two banks. The XO1 bit in the Flag register (CPU_F) determines which bank the user is currently in. When the XO1 bit is set to 1 the user is in Bank 1.

Note In the following register mapping tables, blank fields are Reserved and must not be accessed.

Table 5. Register Map 0 Table: User Space

Name	Addr (0,Hex)	Access	Name	Addr (0,Hex)	Access	Name	Addr (0,Hex)	Access	Name	Addr (0,Hex)	Access
PRT0DR	00	RW		40		ASE10CR0	80	RW		C0	
PRT0IE	01	RW		41			81			C1	
PRT0GS	02	RW		42			82			C2	
PRT0DM2	03	RW		43			83			C3	
PRT1DR	04	RW		44		ASE11CR0	84	RW		C4	
PRT1IE	05	RW		45			85			C5	
PRT1GS	06	RW		46			86			C6	
PRT1DM2	07	RW		47			87			C7	
PRT2DR	08	RW		48			88			C8	
PRT2IE	09	RW		49			89			C9	
PRT2GS	0A	RW		4A			8A			CA	
PRT2DM2	0B	RW		4B			8B			CB	
PRT3DR	0C	RW		4C			8C			CC	
PRT3IE	0D	RW		4D			8D			CD	
PRT3GS	0E	RW		4E			8E			CE	
PRT3DM2	0F	RW		4F			8F			CF	
	10			50			90		CUR_PP	D0	RW
	11			51			91		STK_PP	D1	RW
	12			52			92			D2	
	13			53			93		IDX_PP	D3	RW
	14			54			94		MVR_PP	D4	RW
	15			55			95		MVW_PP	D5	RW
	16			56			96		I2C_CFG	D6	RW
	17			57			97		I2C_SCR	D7	#
	18			58			98		I2C_DR	D8	RW
	19			59			99		I2C_MSCR	D9	#
	1A			5A			9A		INT_CLR0	DA	RW
	1B			5B			9B		INT_CLR1	DB	RW
	1C			5C			9C			DC	

Blank fields are Reserved and must not be accessed.

Access is bit specific.

Table 5. Register Map 0 Table: User Space (continued)

Name	Addr (0,Hex)	Access	Name	Addr (0,Hex)	Access	Name	Addr (0,Hex)	Access	Name	Addr (0,Hex)	Access
	1D			5D			9D		INT_CLR3	DD	RW
	1E			5E			9E		INT_MSK3	DE	RW
	1F			5F			9F			DF	
DBB00DR0	20	#	AMX_IN	60	RW		A0		INT_MSK0	E0	RW
DBB00DR1	21	W	AMUXCFG	61	RW		A1		INT_MSK1	E1	RW
DBB00DR2	22	RW	PWM_CR	62	RW		A2		INT_VC	E2	RC
DBB00CR0	23	#		63			A3		RES_WDT	E3	W
DBB01DR0	24	#	CMP_CR0	64	#		A4			E4	
DBB01DR1	25	W		65			A5			E5	
DBB01DR2	26	RW	CMP_CR1	66	RW		A6		DEC_CR0	E6	RW
DBB01CR0	27	#		67			A7		DEC_CR1	E7	RW
DCB02DR0	28	#	ADC0_CR	68	#		A8			E8	
DCB02DR1	29	W	ADC1_CR	69	#		A9			E9	
DCB02DR2	2A	RW		6A			AA			EA	
DCB02CR0	2B	#		6B			AB			EB	
DCB03DR0	2C	#	TMP_DR0	6C	RW		AC			EC	
DCB03DR1	2D	W	TMP_DR1	6D	RW		AD			ED	
DCB03DR2	2E	RW	TMP_DR2	6E	RW		AE			EE	
DCB03CR0	2F	#	TMP_DR3	6F	RW		AF			EF	
	30			70		RDIORI	B0	RW		F0	
	31			71		RDIOSYN	B1	RW		F1	
	32		ACE00CR1	72	RW	RDIOIS	B2	RW		F2	
	33		ACE00CR2	73	RW	RDIOILT0	B3	RW		F3	
	34			74		RDIOILT1	B4	RW		F4	
	35			75		RDIORO0	B5	RW		F5	
	36		ACE01CR1	76	RW	RDIORO1	B6	RW		F6	
	37		ACE01CR2	77	RW		B7		CPU_F	F7	RL
	38			78			B8			F8	
	39			79			B9			F9	
	3A			7A			BA			FA	
	3B			7B			BB			FB	
	3C			7C			BC			FC	
	3D			7D			BD		DAC_D	FD	RW
	3E			7E			BE		CPU_SCR1	FE	#
	3F			7F			BF		CPU_SCR0	FF	#

Blank fields are Reserved and must not be accessed.

Access is bit specific.

Table 6. Register Map 1 Table: Configuration Space

Name	Addr (1,Hex)	Access	Name	Addr (1,Hex)	Access	Name	Addr (1,Hex)	Access	Name	Addr (1,Hex)	Access
PRT0DM0	00	RW		40		ASE10CR0	80	RW		C0	
PRT0DM1	01	RW		41			81			C1	
PRT0IC0	02	RW		42			82			C2	
PRT0IC1	03	RW		43			83			C3	
PRT1DM0	04	RW		44		ASE11CR0	84	RW		C4	
PRT1DM1	05	RW		45			85			C5	
PRT1IC0	06	RW		46			86			C6	
PRT1IC1	07	RW		47			87			C7	
PRT2DM0	08	RW		48			88			C8	
PRT2DM1	09	RW		49			89			C9	
PRT2IC0	0A	RW		4A			8A			CA	
PRT2IC1	0B	RW		4B			8B			CB	
PRT3DM0	0C	RW		4C			8C			CC	
PRT3DM1	0D	RW		4D			8D			CD	
PRT3IC0	0E	RW		4E			8E			CE	
PRT3IC1	0F	RW		4F			8F			CF	
	10			50			90		GDI_O_IN	D0	RW
	11			51			91		GDI_E_IN	D1	RW
	12			52			92		GDI_O_OU	D2	RW
	13			53			93		GDI_E_OU	D3	RW
	14			54			94			D4	
	15			55			95			D5	
	16			56			96			D6	
	17			57			97			D7	
	18			58			98		MUX_CR0	D8	RW
	19			59			99		MUX_CR1	D9	RW
	1A			5A			9A		MUX_CR2	DA	RW
	1B			5B			9B		MUX_CR3	DB	RW
	1C			5C			9C			DC	
	1D			5D			9D		OSC_GO_EN	DD	RW
	1E			5E			9E		OSC_CR4	DE	RW
	1F			5F			9F		OSC_CR3	DF	RW
DBB00FN	20	RW	CLK_CR0	60	RW		A0		OSC_CR0	E0	RW
DBB00IN	21	RW	CLK_CR1	61	RW		A1		OSC_CR1	E1	RW
DBB00OU	22	RW	ABF_CR0	62	RW		A2		OSC_CR2	E2	RW
	23		AMD_CR0	63	RW		A3		VLT_CR	E3	RW
DBB01FN	24	RW	CMP_GO_EN	64	RW		A4		VLT_CMP	E4	R
DBB01IN	25	RW		65			A5		ADC0_TR	E5	RW
DBB01OU	26	RW	AMD_CR1	66	RW		A6		ADC1_TR	E6	RW
	27		ALT_CR0	67	RW		A7			E7	
DCB02FN	28	RW		68			A8		IMO_TR	E8	W
DCB02IN	29	RW		69			A9		ILO_TR	E9	W
DCB02OU	2A	RW		6A			AA		BDG_TR	EA	RW
	2B		CLK_CR3	6B	RW		AB		ECO_TR	EB	W

Blank fields are Reserved and must not be accessed.

Access is bit specific.

Table 6. Register Map 1 Table: Configuration Space (continued)

Name	Addr (1,Hex)	Access	Name	Addr (1,Hex)	Access	Name	Addr (1,Hex)	Access	Name	Addr (1,Hex)	Access
DCB03FN	2C	RW	TMP_DR0	6C	RW		AC			EC	
DCB03IN	2D	RW	TMP_DR1	6D	RW		AD			ED	
DCB03OU	2E	RW	TMP_DR2	6E	RW		AE			EE	
	2F		TMP_DR3	6F	RW		AF			EF	
	30			70		RDI0RI	B0	RW		F0	
	31			71		RDI0SYN	B1	RW		F1	
	32		ACE00CR1	72	RW	RDI0IS	B2	RW		F2	
	33		ACE00CR2	73	RW	RDI0LT0	B3	RW		F3	
	34			74		RDI0LT1	B4	RW		F4	
	35			75		RDI0RO0	B5	RW		F5	
	36		ACE01CR1	76	RW	RDI0RO1	B6	RW		F6	
	37		ACE01CR2	77	RW		B7		CPU_F	F7	RL
	38			78			B8			F8	
	39			79			B9			F9	
	3A			7A			BA		FLS_PR1	FA	RW
	3B			7B			BB			FB	
	3C			7C			BC			FC	
	3D			7D			BD		DAC_CR	FD	RW
	3E			7E			BE		CPU_SCR1	FE	#
	3F			7F			BF		CPU_SCR0	FF	#

Blank fields are Reserved and must not be accessed.

Access is bit specific.

Electrical Specifications

This section presents the DC and AC electrical specifications of the enCoRe III LV device. For up-to-date electrical specifications, check the latest data sheet by visiting the web at <http://www.cypress.com>.

Specifications are valid for $0\text{ }^{\circ}\text{C} \leq T_A \leq 70\text{ }^{\circ}\text{C}$ and $T_J \leq 85\text{ }^{\circ}\text{C}$ as specified, except where noted.

Refer to [Table 19 on page 22](#) for the electrical specifications for the internal main oscillator (IMO) using SLIMO mode.

Figure 10. Voltage versus CPU Frequency

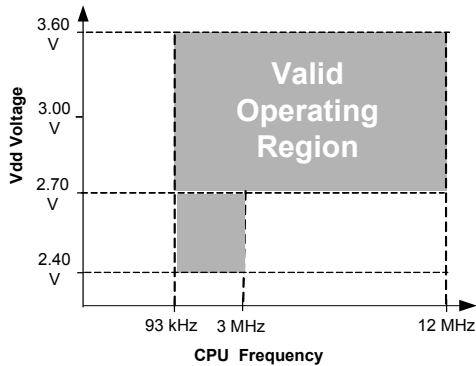
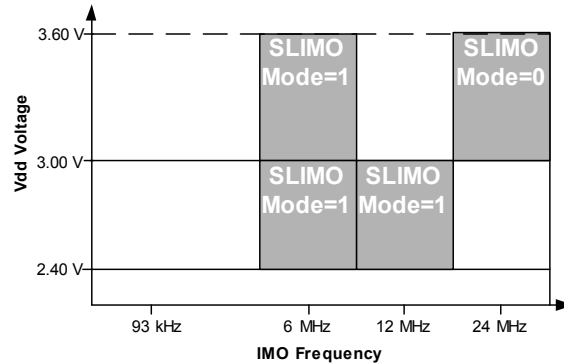

Figure 11. IMO Frequency Trim Options



The allowable CPU operating region for 12 MHz has been extended down to 2.7 V from the original 3.0 V design target. The customer's application is responsible for monitoring voltage and throttling back CPU speed in accordance with [Figure 10](#) when voltage approaches 2.7 V. Refer to [Table 16](#) for LVD specifications. Note that the device does not support a preset trip at 2.7 V. To detect Vdd drop at 2.7 V, an external circuit or device such as the WirelessUSB LP - CYRF6936 must be employed; or if the design permits, the nearest LVD trip value at 2.9 V can be used.

Absolute Maximum Ratings

Table 7. Absolute Maximum Ratings

Parameter	Description	Min	Typ	Max	Unit	Notes
T _{STG}	Storage temperature	-40	-	+90	°C	Higher storage temperatures reduce data retention time.
T _{BAKETEMP}	Bake temperature		125	See package label	°C	
T _{BAKETIME}	Bake time	See package label		72	Hours	
T _A	Ambient temperature with power applied	0	-	+70	°C	
V _{dd}	Supply voltage on V _{dd} relative to V _{ss}	-0.5	-	5	V	
V _{IO}	DC input voltage	V _{ss} - 0.5	-	V _{dd} + 0.5	V	
V _{IOZ}	DC voltage applied to tri-state	V _{ss} - 0.5	-	V _{dd} + 0.5	V	
I _{MIO}	Maximum current into any port pin	-25	-	+25	mA	
ESD	Electro static discharge voltage	2000	-	-	V	Human body model ESD.
LU	Latch up current	-	-	200	mA	

Operating Temperature

Table 8. Operating Temperature

Parameter	Description	Min	Typ	Max	Unit	Notes
T _A	Ambient temperature	0	-	+70	°C	
T _J	Junction temperature	0	-	+85	°C	The temperature rise from ambient to junction is package specific. See Table 31 on page 30 . The user must limit the power consumption to comply with this requirement.

DC Electrical Characteristics

DC Chip-Level Specifications

Table 9 lists guaranteed maximum and minimum specifications for the voltage and temperature ranges: 3.0 V to 3.6 V and $0\text{ }^{\circ}\text{C} \leq T_A \leq 70\text{ }^{\circ}\text{C}$, or 2.4 V to 3.0 V and $0\text{ }^{\circ}\text{C} \leq T_A \leq 70\text{ }^{\circ}\text{C}$, respectively. Typical parameters apply to 3.3 V, or 2.7 V at 25 °C and are for design guidance only.

Table 9. DC Chip-Level Specifications

Parameter	Description	Min	Typ	Max	Unit	Notes
V _{DD}	Supply voltage	2.40	–	3.6	V	See Table 16 on page 20.
I _{DD3}	Supply current, IMO = 6 MHz using SLIMO mode.	–	1.2	2	mA	Conditions are V _{DD} = 3.3 V, T _A = 25 °C, CPU = 3 MHz, clock doubler disabled. VC1 = 375 kHz, VC2 = 23.4 kHz, VC3 = 0.091 kHz.
I _{DD27}	Supply current, IMO = 6 MHz using SLIMO mode.	–	1.1	1.5	mA	Conditions are V _{DD} = 2.55 V, T _A = 25 °C, CPU = 3 MHz, clock doubler disabled. VC1 = 375 kHz, VC2 = 23.4 kHz, VC3 = 0.091 kHz.
I _{SB27}	Sleep (Mode) current with POR, LVD, sleep timer, WDT, and internal slow oscillator active. Mid temperature range.	–	2.6	4.	μA	V _{DD} = 2.55 V, $0\text{ }^{\circ}\text{C} \leq T_A \leq 40\text{ }^{\circ}\text{C}$.
I _{SB}	Sleep (Mode) current with POR, LVD, sleep timer, WDT, and internal slow oscillator active.	–	2.8	5	μA	V _{DD} = 3.3 V, $0\text{ }^{\circ}\text{C} \leq T_A \leq 70\text{ }^{\circ}\text{C}$.
V _{REF}	Reference voltage (Bandgap)	1.28	1.30	1.32	V	Trimmed for appropriate V _{DD} . V _{DD} = 3.0 V to 3.6 V.
V _{REF27}	Reference voltage (Bandgap)	1.16	1.30	1.33	V	Trimmed for appropriate V _{DD} . V _{DD} = 2.4 V to 3.0 V.
AGND	Analog ground	V _{REF} – 0.003	V _{REF}	V _{REF} + 0.003	V	

DC GPIO Specifications

The following tables list guaranteed maximum and minimum specifications for the voltage and temperature ranges: 3.0 V to 3.6 V and $0\text{ }^{\circ}\text{C} \leq T_A \leq 70\text{ }^{\circ}\text{C}$, or 2.4 V to 3.0 V and $0\text{ }^{\circ}\text{C} \leq T_A \leq 70\text{ }^{\circ}\text{C}$, respectively. Typical parameters apply to 3.3 V, and 2.7 V at 25 °C and are for design guidance only.

Table 10. 3.3 V DC GPIO Specifications

Parameter	Description	Min	Typ	Max	Unit	Notes
R _{PU}	Pull-up resistor	4	5.6	8	kΩ	
R _{PD}	Pull-down resistor	4	5.6	8	kΩ	
V _{OH}	High output level	V _{DD} – 1.0	–	–	V	I _{OH} = 3 mA, V _{DD} > 3.0 V
V _{OL}	Low output level	–	–	0.75	V	I _{OL} = 10 mA, V _{DD} > 3.0 V
I _{OH}	High level source current	3	–	–	mA	
I _{OL}	Low level sink current	10	–	–	mA	
V _{IL}	Input low level	–	–	0.8	V	V _{DD} = 3.0 to 3.6.
V _{IH}	Input high level	2.1	–	–	V	V _{DD} = 3.0 to 3.6.
V _H	Input hysteresis	–	60	–	mV	
I _{IL}	Input leakage (absolute value)	–	1	–	nA	Gross tested to 1 μA.
C _{IN}	Capacitive load on pins as input	–	3.5	10	pF	Package and pin dependent. Temp = 25 °C.
C _{OUT}	Capacitive load on pins as output	–	3.5	10	pF	Package and pin dependent. Temp = 25 °C.

Table 11. 2.7V DC GPIO Specifications

Parameter	Description	Min	Typ	Max	Unit	Notes
R _{PU}	Pull-up resistor	4	5.6	8	kΩ	
R _{PD}	Pull-down resistor	4	5.6	8	kΩ	
V _{OH}	High output level	V _{DD} – 0.4	–	–	V	I _{OH} = 2.5 mA (6.25 Typ), V _{DD} = 2.4 to 3.0 V (16 mA maximum, 50 mA Typ combined I _{OH} budget).
V _{OL}	Low output level	–	–	0.75	V	I _{OL} = 10 mA, V _{DD} = 2.4 to 3.0 V (90 mA maximum combined I _{OL} budget).
I _{OH}	High level source current	2.5	–	–	mA	
I _{OL}	Low level sink current	10	–	–	mA	
V _{IL}	Input low level	–	–	0.75	V	V _{DD} = 2.4 to 3.0.
V _{IH}	Input high level	2.0	–	–	V	V _{DD} = 2.4 to 3.0.
V _H	Input hysteresis	–	90	–	mV	
I _{IL}	Input leakage (absolute value)	–	1	–	nA	Gross tested to 1 μA.
C _{IN}	Capacitive load on pins as input	–	3.5	10	pF	Package and pin dependent. Temp = 25 °C.
C _{OUT}	Capacitive load on pins as output	–	3.5	10	pF	Package and pin dependent. Temp = 25 °C.

DC Operational Amplifier Specifications

The following tables list guaranteed maximum and minimum specifications for the voltage and temperature ranges: 3.0 V to 3.6 V and 0 °C ≤ T_A ≤ 70 °C, or 2.4 V to 3.0 V and 0 °C ≤ T_A ≤ 70 °C, respectively. Typical parameters apply to 3.3 V, or 2.7 V at 25 °C and are for design guidance only.

Table 12. 3.3-V DC Operational Amplifier Specifications

Symbol	Description	Min	Typ	Max	Units	Notes
V _O SOA	Input offset voltage (absolute value)	–	2.5	15	mV	
TCV _O SOA	Average input offset voltage drift	–	10	–	μV/°C	
I _E BOA	Input leakage current (Port 0 analog pins)	–	200	–	pA	Gross tested to 1 μA
I _E BOA00	Input leakage current (Port 0, Pin 0 analog pin)	–	50	–	nA	Gross tested to 1 μA
C _I NOA	Input capacitance (Port 0 analog pins)	–	4.5	9.5	pF	Package and pin dependent. Temp = 25 °C
V _C MOA	Common mode voltage range	0	–	V _{DD} – 1	V	
G _O LOA	Open loop gain	–	80	–	dB	
I _S OA	Amplifier supply current	–	10	30	μA	

Table 13. 2.7-V DC Operational Amplifier Specifications

Symbol	Description	Min	Typ	Max	Units	Notes
V _O SOA	Input offset voltage (absolute value)	–	2.5	15	mV	
TCV _O SOA	Average input offset voltage drift	–	10	–	μV/°C	
I _E BOA	Input leakage current (Port 0 analog pins)	–	200	–	pA	Gross tested to 1 μA
I _E BOA00	Input leakage current (Port 0, Pin 0 analog pin)	–	50	–	nA	Gross tested to 1 μA
C _I NOA	Input capacitance (Port 0 analog pins)	–	4.5	9.5	pF	Package and pin dependent. Temp = 25 °C
V _C MOA	Common mode voltage range	0	–	V _{DD} – 1	V	
G _O LOA	Open loop gain	–	80	–	dB	
I _S OA	Amplifier supply current	–	10	30	μA	

DC Switch Mode Pump Specifications

Table 14 lists guaranteed maximum and minimum specifications for the voltage and temperature ranges: 3.0 V to 3.6 V and $0\text{ }^{\circ}\text{C} \leq T_A \leq 70\text{ }^{\circ}\text{C}$, or 2.4 V to 3.0 V and $0\text{ }^{\circ}\text{C} \leq T_A \leq 70\text{ }^{\circ}\text{C}$, respectively. Typical parameters apply to 3.3 V, or 2.7 V at $25\text{ }^{\circ}\text{C}$ and are for design guidance only.

Table 14. DC Switch Mode Pump (SMP) Specifications

Parameter	Description	Min	Typ	Max	Unit	Notes
V _{PUMP3V}	3.3 V output voltage from pump	3.00	3.25	3.60	V	Configuration of footnote. ^[2] Average, neglecting ripple. SMP trip voltage is set to 3.25 V.
V _{PUMP2V}	2.6 V output voltage from pump	2.45	2.55	2.80	V	Configuration of footnote. ^[2] average, neglecting ripple. SMP trip voltage is set to 2.55 V.
I _{PUMP}	Available output current V _{BAT} = 1.5 V, V _{PUMP} = 3.25 V V _{BAT} = 1.3 V, V _{PUMP} = 2.55 V	8 8	– –	– –	mA mA	Configuration of footnote. ^[2] SMP trip voltage is set to 3.25 V. SMP trip voltage is set to 2.55 V.
V _{BAT3V}	Input voltage range from battery	1.0	–	3.3	V	Configuration of footnote. ^[2] SMP trip voltage is set to 3.25 V.
V _{BAT2V}	Input voltage range from vattery	1.0	–	2.8	V	Configuration of footnote. ^[2] SMP trip voltage is set to 2.55 V.
V _{BATSTART}	Minimum input voltage from vattery to start pump	1.2	–	–	V	Configuration of footnote. ^[2] $0\text{ }^{\circ}\text{C} \leq T_A \leq 100\text{ }^{\circ}\text{C}$. 1.25 V at $T_A = -40\text{ }^{\circ}\text{C}$.
$\Delta V_{\text{PUMP_Line}}$	Line regulation (over Vi range)	–	5	–	%V _O	Configuration of footnote. ^[2] V _O is the Vdd value for PUMP trip specified by the VM[2:0] setting in the DC POR and LVD specification, Table 16 on page 20.
$\Delta V_{\text{PUMP_Load}}$	Load regulation	–	5	–	%V _O	Configuration of footnote. ^[2] V _O is the “Vdd Value for PUMP Trip” specified by the VM[2:0] setting in the DC POR and LVD specification, Table 16 on page 20.
$\Delta V_{\text{PUMP_Ripple}}$	Output vovltage ripple (depends on cap/load)	–	100	–	mVpp	Configuration of footnote. ^[2] Load is 5 mA.
E ₃	Efficiency	35	50	–	%	Configuration of footnote. ^[2] Load is 5 mA. SMP trip voltage is set to 3.25 V.
E ₂	Efficiency	35	80	–	%	For I load = 1 mA, V _{PUMP} = 2.55 V, V _{BAT} = 1.3 V, 10 μH inductor, 1 μF capacitor, and Schottky diode.
F _{PUMP}	Switching frequency	–	1.3	–	MHz	
DC _{PUMP}	Switching duty cycle	–	50	–	%	

Note

2. L₁ = 2 μH inductor, C₁ = 10 μF capacitor, D₁ = Schottky diode. See Figure 12 on page 20.

Figure 12. Basic Switch Mode Pump Circuit

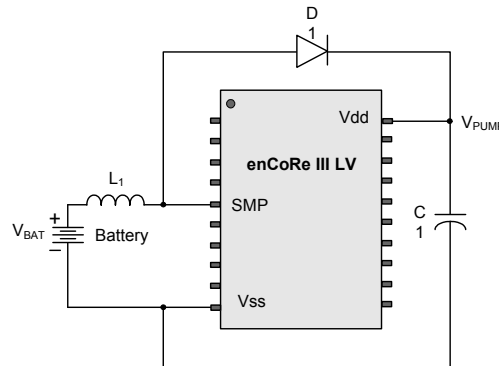

DC Analog Mux Bus Specifications

Table 15 lists guaranteed maximum and minimum specifications for the voltage and temperature ranges: 3.0 V to 3.6 V and $0\text{ }^{\circ}\text{C} \leq T_A \leq 70\text{ }^{\circ}\text{C}$, or 2.4 V to 3.0 V and $0\text{ }^{\circ}\text{C} \leq T_A \leq 70\text{ }^{\circ}\text{C}$, respectively. Typical parameters apply to 3.3 V, or 2.7 V at 25 $^{\circ}\text{C}$ and are for design guidance only.

Table 15. DC Analog Mux Bus Specifications

Parameter	Description	Min	Typ	Max	Unit	Notes
R _{SW}	Switch resistance to common analog bus	–	–	400 800	Ω Ω	V _{dd} ≥ 2.7 V 2.4 V ≤ V _{dd} ≤ 2.7 V
R _{VDD}	Resistance of initialization switch to V _{dd}	–	–	800	Ω	

DC POR and LVD Specifications

Table 16 lists guaranteed maximum and minimum specifications for the voltage and temperature ranges: 3.0 V to 3.6 V and $0\text{ }^{\circ}\text{C} \leq T_A \leq 70\text{ }^{\circ}\text{C}$, or 2.4 V to 3.0 V and $0\text{ }^{\circ}\text{C} \leq T_A \leq 70\text{ }^{\circ}\text{C}$, respectively. Typical parameters apply to 3.3 V, or 2.7 V at 25 $^{\circ}\text{C}$ and are for design guidance only.

Table 16. DC POR and LVD Specifications

Parameter	Description	Min	Typ	Max	Unit	Notes
V _{PPOR0} V _{PPOR1}	V _{dd} value for PPOR Trip PORLEV[1:0] = 00b PORLEV[1:0] = 01b	–	2.36 2.82	2.40 2.95	V V	V _{dd} must be greater than or equal to 2.5 V during startup, reset from the XRES pin, or reset from Watchdog.
V _{LVD0} V _{LVD1} V _{LVD2} V _{LVD37}	V _{dd} value for LVD Trip VM[2:0] = 000b VM[2:0] = 001b VM[2:0] = 010b VM[2:0] = 011b	2.40 2.85 2.95 3.06	2.45 2.92 3.02 3.13	2.51 ^[3] 2.99 ^[4] 3.09 3.20	V V V V	
V _{PUMP0} V _{PUMP1} V _{PUMP2} V _{PUMP3}	V _{dd} value for PUMP Trip VM[2:0] = 000b VM[2:0] = 001b VM[2:0] = 010b VM[2:0] = 011b	2.45 2.96 3.03 3.18	2.55 3.02 3.10 3.25	2.62 ^[5] 3.09 3.16 3.32 ^[6]	V V V V	

Notes

3. Always greater than 50 mV above V_{PPOR} (PORLEV = 00) for falling supply.
4. Always greater than 50 mV above V_{PPOR} (PORLEV = 01) for falling supply.
5. Always greater than 50 mV above V_{LVD0}.
6. Always greater than 50 mV above V_{LVD3}.

DC Programming Specifications

Table 17 lists guaranteed maximum and minimum specifications for the voltage and temperature ranges: 3.0 V to 3.6 V and $0\text{ }^{\circ}\text{C} \leq T_A \leq 70\text{ }^{\circ}\text{C}$, or 2.4 V to 3.0 V and $0\text{ }^{\circ}\text{C} \leq T_A \leq 70\text{ }^{\circ}\text{C}$, respectively. Typical parameters apply to 3.3 V, or 2.7 V at 25 °C and are for design guidance only.

Table 17. DC Programming Specifications

Parameter	Description	Min	Typ	Max	Unit	Notes
V _{DDP}	V _{DD} for programming and erase	4.5	5.0	5.5	V	This specification applies to the functional requirements of external programmer tools.
V _{DDL}	Low V _{DD} for verify	2.4	2.5	2.6	V	This specification applies to the functional requirements of external programmer tools.
V _{DDH}	High V _{DD} for verify	3.5	3.6	3.7	V	This specification applies to the functional requirements of external programmer tools.
V _{DDIWRITE}	Supply voltage for flash write operation	2.7	–	3.6	V	This specification applies to this device when it is executing internal flash writes.
I _{DDP}	Supply current during programming or verify	–	5	25	mA	
V _{ILP}	Input low voltage during programming or verify	–	–	0.8	V	
V _{IHP}	Input high voltage during programming or verify	2.1	–	–	V	
I _{ILP}	Input current when applying V _{ilp} to P1[0] or P1[1] during programming or verify	–	–	0.2	mA	Driving internal pull down resistor.
I _{IHP}	Input current when applying V _{ihp} to P1[0] or P1[1] during programming or verify	–	–	1.5	mA	Driving internal pull down resistor.
V _{OLV}	Output low voltage during programming or verify	–	–	V _{ss} + 0.75	V	
V _{OHV}	Output high voltage during programming or verify	V _{dd} – 1.0	–	V _{dd}	V	
Flash _{ENPB}	Flash endurance (per block)	50,000 ^[7]	–	–	–	Erase/write cycles per block.
Flash _{ENT}	Flash endurance (total) ^[8]	1,800,000	–	–	–	Erase/write cycles.
Flash _{DR}	Flash data retention	10	–	–	Years	

DC I²C Specifications

Table 18 lists guaranteed maximum and minimum specifications for the voltage and temperature ranges: 3.0 V to 3.6 V and $0\text{ }^{\circ}\text{C} \leq T_A \leq 70\text{ }^{\circ}\text{C}$, or 2.4 V to 3.0 V and $0\text{ }^{\circ}\text{C} \leq T_A \leq 70\text{ }^{\circ}\text{C}$, respectively. Typical parameters apply to 3.3 V, or 2.7 V at 25 °C and are for design guidance only.

Table 18. DC I²C Specifications^[9]

Symbol	Description	Min	Typ	Max	Units	Notes
V _{IL2C}	Input low level	–	–	0.3 × V _{DD}	V	2.4 V ≤ V _{DD} ≤ 3.6 V
V _{IH2C}	Input high level	0.7 × V _{DD}	–	–	V	2.4 V ≤ V _{DD} ≤ 3.6 V

Notes

- The 50,000 cycle Flash endurance per block will only be guaranteed if the Flash is operating within one voltage range. Voltage ranges are 2.4 V to 3.0 V and 3.0 V to 3.6 V.
- A maximum of 36 × 50,000 block endurance cycles is allowed. This may be balanced between operations on 36x1 blocks of 50,000 maximum cycles each, 36x2 blocks of 25,000 maximum cycles each, or 36x4 blocks of 12,500 maximum cycles each (to limit the total number of cycles to 36x50,000 and that no single block ever sees more than 50,000 cycles).
- All GPIO meet the DC GPIO V_{IL} and V_{IH} specifications found in the DC GPIO Specifications sections. The I²C GPIO pins also meet the above specs.

AC Electrical Characteristics

AC Chip-Level Specifications

The following tables list guaranteed maximum and minimum specifications for the voltage and temperature ranges: 3.0 V to 3.6 V and $0\text{ }^{\circ}\text{C} \leq T_A \leq 70\text{ }^{\circ}\text{C}$, or 2.4 V to 3.0 V and $0\text{ }^{\circ}\text{C} \leq T_A \leq 70\text{ }^{\circ}\text{C}$, respectively. Typical parameters apply to 3.3 V, or 2.7 V at 25 °C and are for design guidance only.

Table 19. 3.3 V AC Chip-Level Specifications

Parameter	Description	Min	Typ	Max	Unit	Notes
F _{IMO24}	Internal main oscillator frequency for 24 MHz	23.4	24	24.6 ^[10, 11]	MHz	Trimmed for 3.3 V operation using factory trim values. See Figure 11 on page 15 . SLIMO mode = 0.
F _{IMO6}	Internal main oscillator frequency for 6 MHz	5.5	6	6.5 ^[10, 11]	MHz	Trimmed for 3.3 V operation using factory trim values. See Figure 11 on page 15 . SLIMO mode = 1.
F _{CPU2}	CPU frequency (3.3 V nominal)	0.093	12	12.3 ^[10, 11]	MHz	SLIMO mode = 0.
F _{BLK33}	Digital block frequency (3.3 V nominal)	0	24	24.6 ^[10, 12]	MHz	
F _{32K1}	Internal low speed oscillator frequency	15	32	64	kHz	
F _{32K_U}	Internal low speed oscillator untrimmed frequency	5	–	100	kHz	
DC _{ILO}	Internal low speed oscillator duty cycle	20	50	80	%	
T _{XRST}	External reset pulse width	10	–	–	μs	
DC _{24M}	24 MHz duty cycle	40	50	60	%	
Step _{24M}	24 MHz Trim step size	–	50	–	kHz	
F _{out48M}	48 MHz output frequency	46.8	48.0	49.2 ^[11]	MHz	Trimmed. Using factory trim values.
F _{MAX}	Maximum frequency of signal on row input or row output.	–	–	12.3	MHz	
SR _{POWER_UP}	Power supply slew rate	–	–	250	V / ms	
T _{POWERUP}	Time from end of POR to CPU executing code	–	16	100	ms	
t _{jit_IMO}	24-MHz IMO cycle-to-cycle jitter (RMS) ^[13]	–	200	700	ps	
	24-MHz IMO long term N cycle-to-cycle jitter (RMS) ^[13]	–	300	900	ps	N = 32
	24-MHz IMO period jitter (RMS) ^[13]	–	100	400	ps	

Notes

10. Accuracy derived from Internal Main Oscillator with appropriate trim for Vdd range.

11. 3.0 V < Vdd < 3.6 V.

12. See the individual user module data sheets for information on maximum frequencies for user modules.

13. Refer to Cypress Jitter Specifications Application Note [AN5054 "Understanding Datasheet Jitter Specifications for Cypress Timing Products"](#) at www.cypress.com under Application Notes for more information.

Table 20. 2.7 V AC Chip-Level Specifications

Parameter	Description	Min	Typ	Max	Unit	Notes
F _{IMO12}	Internal main oscillator frequency for 12 MHz	11.5	12	12.7 ^[14, 15]	MHz	Trimmed for 2.7 V operation using factory trim values. See Figure 11 on page 15 . SLIMO mode = 1.
F _{IMO6}	Internal main oscillator frequency for 6 MHz	5.5	6	6.5 ^[14, 15]	MHz	Trimmed for 2.7 V operation using factory trim values. See Figure 11 on page 15 . SLIMO mode = 1.
F _{CPU1}	CPU frequency (2.7 V nominal)	0.093	3	3.15 ^[14, 15]	MHz	12 MHz only for SLIMO mode = 0.
F _{BLK27}	Digital block frequency (2.7 V nominal)	0	12	12.5 ^[14, 15]	MHz	Refer to the AC digital block specifications.
F _{32K1}	Internal low speed oscillator frequency	8	32	96	kHz	
F _{32K_U}	Internal low speed oscillator untrimmed frequency	5	–	100	kHz	
DC _{ILO}	Internal low speed oscillator duty cycle	20	50	80	%	
T _{XRST}	External reset pulse width	10	–	–	μs	
F _{MAX}	Maximum frequency of signal on row input or row output.	–	–	12.3	MHz	
SR _{POWER_UP}	Power supply slew rate	–	–	250	V / ms	
T _{POWERUP}	Time from End of POR to CPU executing code	–	16	100	ms	
t _{jit_IMO}	12 MHz IMO cycle-to-cycle jitter (RMS) ^[16]	–	400	1000	ps	
	12 MHz IMO long term N cycle-to-cycle jitter (RMS) ^[16]	–	600	1300	ps	N = 32
	12 MHz IMO period jitter (RMS) ^[16]	–	100	500	ps	

Notes

14. Accuracy derived from Internal Main Oscillator with appropriate trim for Vdd range.

15. 2.4 V < Vdd < 3.0 V.

 16. Refer to Cypress Jitter Specifications Application Note [AN5054](#) "Understanding Datasheet Jitter Specifications for Cypress Timing Products" at www.cypress.com under Application Notes for more information.

AC GPIO Specifications

The following tables list guaranteed maximum and minimum specifications for the voltage and temperature ranges: 3.0 V to 3.6 V and $0\text{ }^{\circ}\text{C} \leq T_A \leq 70\text{ }^{\circ}\text{C}$, or 2.4 V to 3.0 V and $0\text{ }^{\circ}\text{C} \leq T_A \leq 70\text{ }^{\circ}\text{C}$, respectively. Typical parameters apply to 3.3 V, or 2.7 V at 25 °C and are for design guidance only.

Table 21. 3.3 V AC GPIO Specifications

Parameter	Description	Min	Typ	Max	Unit	Notes
F _{GPIO}	GPIO operating frequency	0	–	12	MHz	Normal Strong Mode
TRiseS	Rise time, slow strong mode, load = 50 pF	7	27	–	ns	V _{dd} = 3 to 3.6 V, 10%–90%
TFallS	Fall time, slow strong mode, load = 50 pF	7	22	–	ns	V _{dd} = 3 to 3.6 V, 10%–90%

Table 22. 2.7 V AC GPIO Specifications

Parameter	Description	Min	Typ	Max	Unit	Notes
F _{GPIO}	GPIO operating frequency	0	–	3	MHz	Normal Strong Mode
TRiseF	Rise time, normal strong mode, load = 50 pF	6	–	50	ns	V _{dd} = 2.4 to 3.0 V, 10%–90%
TFallF	Fall time, normal strong mode, load = 50 pF	6	–	50	ns	V _{dd} = 2.4 to 3.0 V, 10%–90%
TRiseS	Rise time, slow strong mode, load = 50 pF	18	40	120	ns	V _{dd} = 2.4 to 3.0 V, 10%–90%
TFallS	Fall time, slow strong mode, load = 50 pF	18	40	120	ns	V _{dd} = 2.4 to 3.0 V, 10%–90%

Figure 13. GPIO Timing Diagram

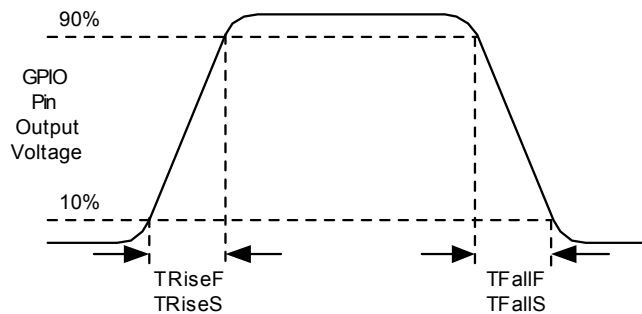

AC Operational Amplifier Specifications

Table 23 lists guaranteed maximum and minimum specifications for the voltage and temperature ranges: 3.0 V to 3.6 V and $0\text{ }^{\circ}\text{C} \leq T_A \leq 70\text{ }^{\circ}\text{C}$, or 2.4 V to 3.0 V and $0\text{ }^{\circ}\text{C} \leq T_A \leq 70\text{ }^{\circ}\text{C}$, respectively. Typical parameters apply to 3.3 V, or 2.7V at 25 °C and are for design guidance only.

Table 23. AC Operational Amplifier Specifications

Parameter	Description	Min	Typ	Max	Unit	Notes
T _{COMP}	Comparator mode response time, 50 mV overdrive			100 200	ns ns	V _{dd} ≥ 3.0 V. 2.4 V < V _{cc} < 3.0 V.

AC Digital Block Specifications

The following tables list guaranteed maximum and minimum specifications for the voltage and temperature ranges: 3.0 V to 3.6 V and $0\text{ }^{\circ}\text{C} \leq T_A \leq 70\text{ }^{\circ}\text{C}$, or 2.4 V to 3.0 V and $0\text{ }^{\circ}\text{C} \leq T_A \leq 70\text{ }^{\circ}\text{C}$, respectively. Typical parameters apply to 3.3 V, or 2.7 V at 25 °C and are for design guidance only.

Table 24. 3.3 V AC Digital Block Specifications

Function	Description	Min	Typ	Max	Unit	Notes
All Functions	Block input clock frequency	–	–	24.6	MHz	3.0 V < Vdd < 3.6 V.
Timer/Counter/PWM	Enable input pulse width	50 ^[17]	–	–	ns	
	Input clock frequency	–	–	24.6	MHz	
Dead Band	Kill pulse width:					
	Asynchronous restart mode	20	–	–	ns	
	Synchronous restart mode	50	–	–	ns	
	Disable mode	50	–	–	ns	
	Input clock frequency	–	–	24.6	MHz	3.0 V ≤ Vdd ≤ 3.6 V.
SPIM	Input clock frequency	–	–	8.2	MHz	The SPI serial clock (SCLK) frequency is equal to the input clock frequency divided by 2.
SPIS	Input clock frequency	–	–	4.1	MHz	Note for SPIS Input Clock Frequency: The input clock is the SPI SCLK in SPIS mode.
	Width of SS_ Negated between transmissions	50	–	–	ns	
Transmitter	Input clock frequency	–	–	24.6	MHz	The baud rate is equal to the input clock frequency divided by 8.
Receiver	Input clock frequency	–	–	24.6	MHz	The baud rate is equal to the input clock frequency divided by 8.

Table 25. 2.7 V AC Digital Block Specifications

Function	Description	Min	Typ	Max	Unit	Notes
All Functions	Block input clock frequency	–	–	12.7	MHz	2.4 V ≤ Vdd ≤ 3.0 V.
Timer/Counter/PWM	Enable input clock width	100	–	–	ns	
	Input clock frequency	–	–	12.7	MHz	
Dead Band	Kill pulse width:					
	Asynchronous restart mode	20	–	–	ns	
	Synchronous restart mode	100	–	–	ns	
	Disable mode	100	–	–	ns	
	Input clock frequency	–	–	12.7	MHz	2.4 V ≤ Vdd < 3.0 V.
SPIM	Input clock frequency	–	–	6.35	MHz	The SPI serial clock (SCLK) frequency is equal to the input clock frequency divided by 2.
SPIS	Input clock frequency	–	–	4.1	MHz	Note for input clock frequency: The input clock is the SPI SCLK in SPIS mode.
	Width of SS_ Negated between transmissions	100	–	–	ns	
Transmitter	Input clock frequency	–	–	12.7	MHz	The baud rate is equal to the input clock frequency divided by 8.
Receiver	Input clock frequency	–	–	12.7	MHz	The baud rate is equal to the input clock frequency divided by 8.

Note

17. 50 ns minimum input pulse width is based on the input synchronizers running at 12 MHz (84 ns nominal period).

AC External Clock Specifications

The following tables list guaranteed maximum and minimum specifications for the voltage and temperature ranges: 3.0 V to 3.6 V and $0\text{ }^{\circ}\text{C} \leq T_A \leq 70\text{ }^{\circ}\text{C}$, respectively. Typical parameters apply to 3.3 V, or 2.7 V at 25 °C and are for design guidance only.

Table 26. 3.3 V AC External Clock Specifications

Parameter	Description	Min	Typ	Max	Unit	Notes
F _{OSCEXT}	Frequency with CPU clock divide by 1	0.093	–	12.3	MHz	Maximum CPU frequency is 12 MHz at 3.3 V. With the CPU clock divider set to 1, the external clock must adhere to the maximum frequency and duty cycle requirements.
F _{OSCEXT}	Frequency with CPU clock divide by 2 or greater	0.186	–	24.6	MHz	If the frequency of the external clock is greater than 12 MHz, the CPU clock divider must be set to 2 or greater. In this case, the CPU clock divider ensures that the fifty percent duty cycle requirement is met.
–	High period with CPU clock divide by 1	41.7	–	5300	ns	
–	Low period with CPU clock divide by 1	41.7	–	–	ns	
–	Power-up IMO to switch	150	–	–	μs	

Table 27. 2.7 V AC External Clock Specifications

Parameter	Description	Min	Typ	Max	Unit	Notes
F _{OSCEXT}	Frequency with CPU clock divide by 1	0.093	–	3.08	MHz	Maximum CPU frequency is 3 MHz at 2.7 V. With the CPU clock divider set to 1, the external clock must adhere to the maximum frequency and duty cycle requirements.
F _{OSCEXT}	Frequency with CPU clock divide by 2 or greater	0.186	–	6.35	MHz	If the frequency of the external clock is greater than 3 MHz, the CPU clock divider must be set to 2 or greater. In this case, the CPU clock divider ensures that the fifty percent duty cycle requirement is met.
–	High period with CPU clock divide by 1	160	–	5300	ns	
–	Low period with CPU clock divide by 1	160	–	–	ns	
–	Power-up IMO to switch	150	–	–	μs	

AC Programming Specifications

Table 28 lists guaranteed maximum and minimum specifications for the voltage and temperature ranges: 3.0 V to 3.6 V and $0\text{ }^{\circ}\text{C} \leq T_A \leq 70\text{ }^{\circ}\text{C}$, respectively. Typical parameters apply to 3.3 V, or 2.7 V at 25 °C and are for design guidance only.

Table 28. AC Programming Specifications

Parameter	Description	Min	Typ	Max	Unit	Notes
T _{RSCLK}	Rise time of SCLK	1	–	20	ns	
T _{FSCLK}	Fall time of SCLK	1	–	20	ns	
T _{SSCLK}	Data set up time to falling edge of SCLK	40	–	–	ns	
T _{HSCLK}	Data hold time from falling edge of SCLK	40	–	–	ns	
F _{SCLK}	Frequency of SCLK	0	–	8	MHz	
T _{ERASEB}	Flash erase time (Block)	–	10	–	ms	
T _{WRITE}	Flash block write time	–	40	–	ms	
T _{DSCLK3}	Data out delay from falling edge of SCLK	–	–	50	ns	3.0 ≤ V _{dd} ≤ 3.6
T _{DSCLK2}	Data out delay from falling edge of SCLK	–	–	70	ns	2.4 ≤ V _{dd} ≤ 3.0
T _{ERASEALL}	Flash erase time (Bulk)	–	20	–	ms	Erase all blocks and protection fields at once.
T _{PROGRAM_HOT}	Flash block erase + flash block write time	–	–	100	ms	0 °C ≤ T _J ≤ 100 °C
T _{PROGRAM_COLD}	Flash block erase + flash block write time	–	–	200	ms	-40 °C ≤ T _J ≤ 0 °C

AC I²C Specifications

The following tables list guaranteed maximum and minimum specifications for the voltage and temperature ranges: 3.0 V to 3.6 V and 0 °C ≤ T_A ≤ 70 °C, or 2.4 V to 3.0 V and 0 °C ≤ T_A ≤ 70 °C, respectively. Typical parameters apply to 3.3 V, or 2.7 V at 25 °C and are for design guidance only.

Table 29. AC Characteristics of the I²C SDA and SCL Pins for V_{dd} ≥ 3.0 V

Parameter	Description	Standard-Mode		Fast-Mode		Unit
		Min	Max	Min	Max	
F _{SCL I2C}	SCL clock frequency	0	100	0	400	kHz
T _{HDSTAI2C}	Hold time (repeated) START condition. After this period, the first clock pulse is generated.	4.0	–	0.6	–	μs
T _{LOW I2C}	LOW period of the SCL clock	4.7	–	1.3	–	μs
T _{HIGH I2C}	HIGH period of the SCL clock	4.0	–	0.6	–	μs
T _{SUSTAI2C}	Set up time for a repeated START condition	4.7	–	0.6	–	μs
T _{HDDATI2C}	Data hold time	0	–	0	–	μs
T _{SUDATI2C}	Data setup time	250	–	100 ^[18]	–	ns
T _{SUSTOI2C}	Set up time for STOP condition	4.0	–	0.6	–	μs
T _{BUF I2C}	Bus free time between a STOP and START condition	4.7	–	1.3	–	μs
T _{SPI2C}	Pulse width of spikes are suppressed by the input filter.	–	–	0	50	ns

Table 30. 2.7 V AC Characteristics of the I²C SDA and SCL Pins (Fast-Mode not Supported)

Parameter	Description	Standard-Mode		Fast-Mode		Unit
		Min	Max	Min	Max	
F _{SCL I2C}	SCL clock frequency	0	100	–	–	kHz
T _{HDSTAI2C}	Hold time (repeated) START condition. After this period, the first clock pulse is generated.	4.0	–	–	–	μs
T _{LOW I2C}	LOW period of the SCL clock	4.7	–	–	–	μs
T _{HIGH I2C}	HIGH period of the SCL clock	4.0	–	–	–	μs
T _{SUSTAI2C}	Setup time for a repeated START condition	4.7	–	–	–	μs
T _{HDDATI2C}	Data hold time	0	–	–	–	μs
T _{SUDATI2C}	Data setup time	250	–	–	–	ns
T _{SUSTOI2C}	Setup Time for STOP Condition	4.0	–	–	–	μs
T _{BUF I2C}	Bus free time between a STOP and START condition	4.7	–	–	–	μs
T _{SPI2C}	Pulse width of spikes are suppressed by the input filter.	–	–	–	–	ns

Note

18. A fast-mode I²C-bus device can be used in a standard-mode I²C-bus system, but the requirement t_{SU, DAT} ≥ 250 ns must then be met. This is automatically the case if the device does not stretch the LOW period of the SCL signal. If such device does stretch the LOW period of the SCL signal, it must output the next data bit to the SDA line t_{rmax} + t_{SU, DAT} = 1000 + 250 = 1250 ns (according to the Standard-Mode I2C-bus specification) before the SCL line is released.

Figure 14. Definition of Timing for Fast-/Standard-Mode on the I²C Bus

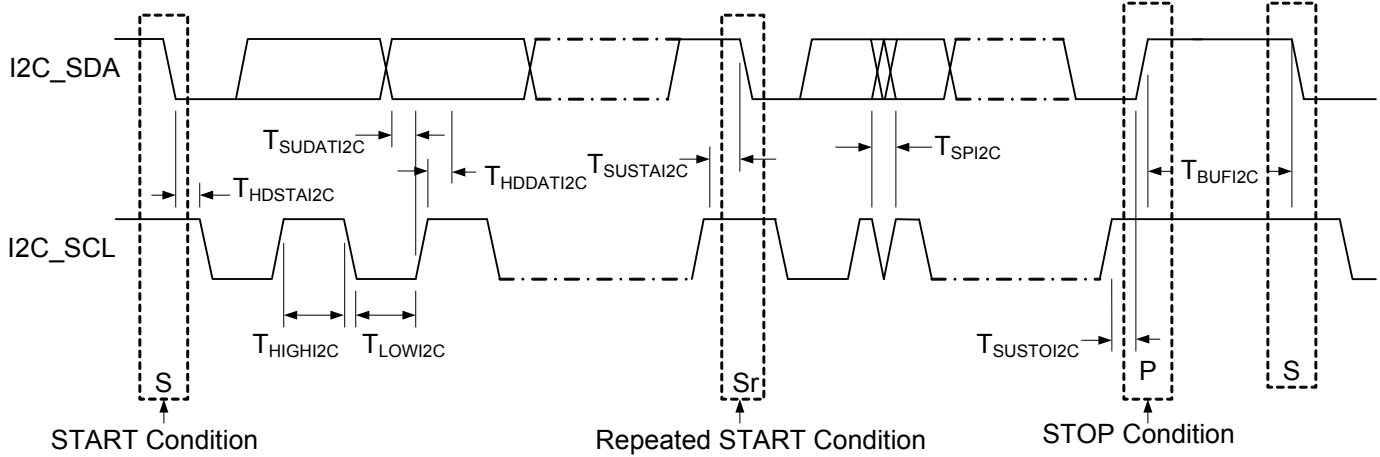

Packaging Information

This section illustrates the packaging specifications for the CY7C603xx device, along with the thermal impedances for each package.

Important Note Emulation tools may require a larger area on the target PCB than the chip's footprint. For a detailed description of the emulation tools' dimensions, refer to the document titled PSoC Emulator Pod Dimensions at <http://www.cypress.com>.

Packaging Dimensions

Figure 15. 28-pin (210-Mil) SSOP

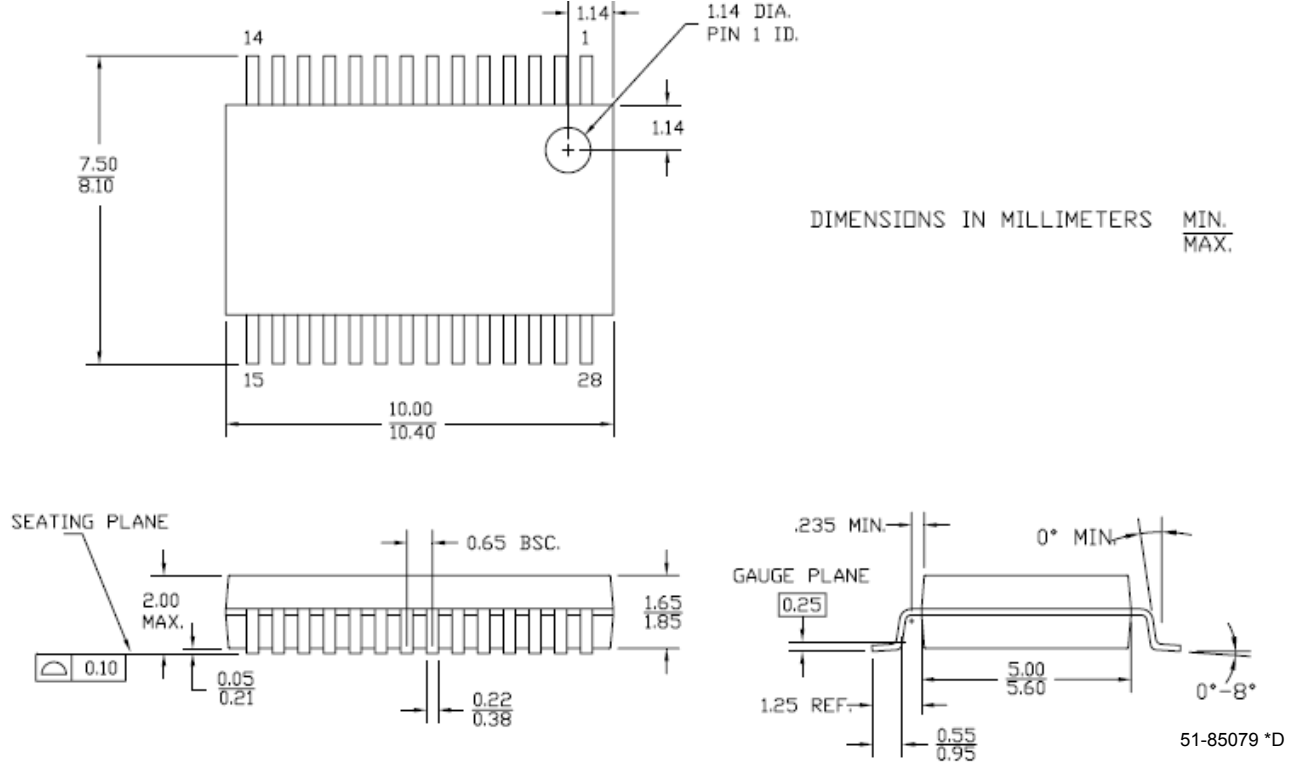
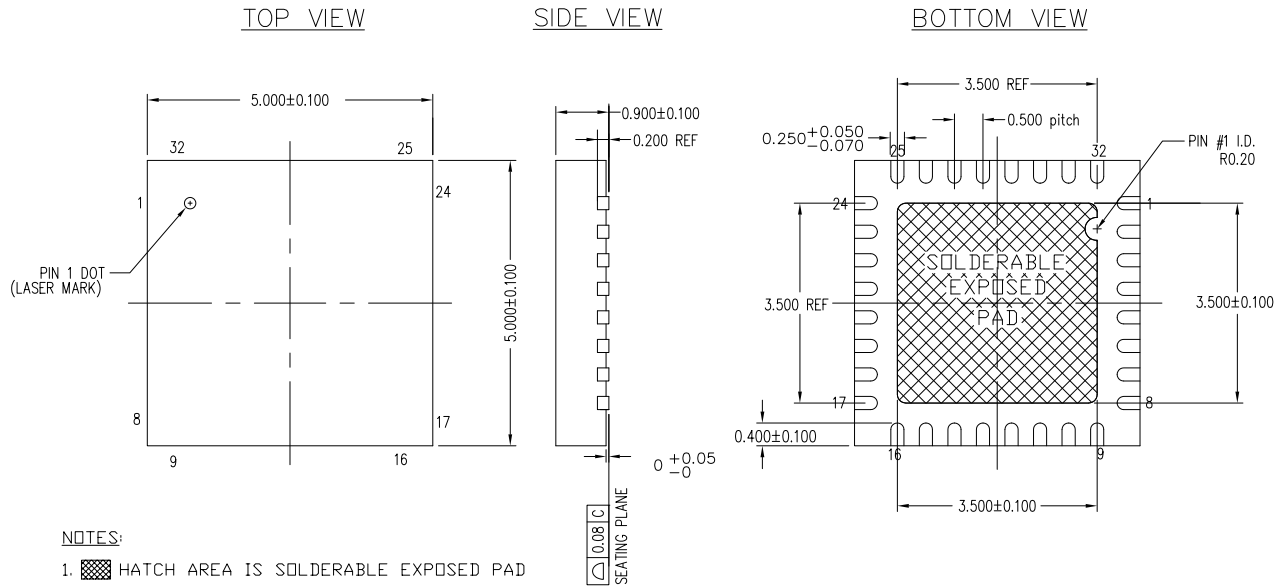



Figure 16. 32-pin QFN (5 × 5 mm) (SAWN)



NOTES:

1.  HATCH AREA IS SOLDERABLE EXPOSED PAD
2. BASED ON REF JEDEC # MO-220
3. PACKAGE WEIGHT: 0.058g
4. DIMENSIONS ARE IN MILLIMETERS

001-30999 °C

Thermal Impedances

Table 31. Thermal Impedances per Package

Package	Typical θ_{JA} ^[19]	Typical θ_{JC}
28 SSOP	96 °C / W	39 °C / W
32 QFN ^[21]	22 °C / W	12 °C / W

Solder Reflow Peak Temperature

Following is the minimum solder reflow peak temperature to achieve good solderability.

Table 32. Solder Reflow Peak Temperature

Package	Maximum Peak Temperature	Time at Maximum Peak Temperature
28 SSOP	260 °C	20 s
32 QFN	260 °C	20 s

Notes

19. $T_J = T_A + \text{Power} \times \theta_{JA}$

20. Higher temperatures may be required based on the solder melting point. Typical temperatures for solder are 220 ± 5 °C with Sn-Pb or 245 ± 5 °C with Sn-Ag-Cu paste. Refer to the solder manufacturer specifications.

21. To achieve the thermal impedance specified for the QFN package, refer to "Application Notes for Surface Mount Assembly of Amkor's MicroLead-Frame (MLF) Packages" available at <http://www.amkor.com>.

Ordering Information

The following table lists the CY7C603xx device's key package features and ordering codes

Table 33. CY7C603xx Device Key Features and Ordering Information

Package Type	Ordering Part Number	Flash Size	RAM Size	SMP	I/O
28-SSOP	CY7C60323-PVXC	8K	512	No	24
28-SSOP Tape and Reel	CY7C60323-PVXCT	8K	512	No	24
32-QFN SAWN	CY7C60323-LTXC	8K	512	No	28
32-QFN SAWN Tape and Reel	CY7C60323-LTXCT	8K	512	No	28
32-QFN SAWN	CY7C60333-LTXC	8K	512	Yes	26
32-QFN SAWN Tape and Reel	CY7C60333-LTXCT	8K	512	Yes	26

Ordering Code Definitions

CY 7 C 60 xxx

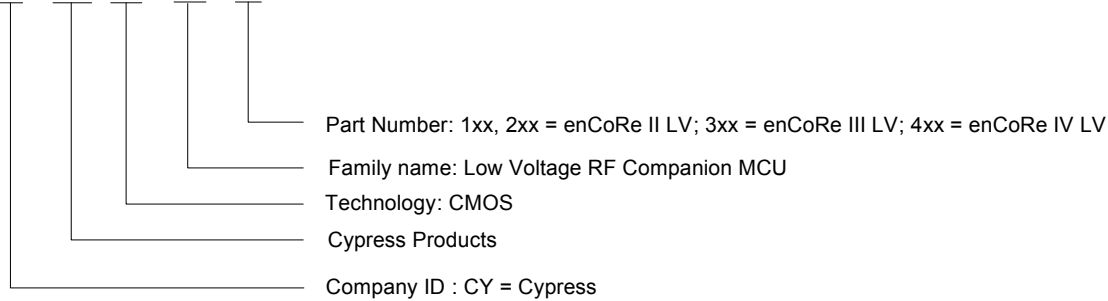

Acronyms

Acronyms Used

Table 34 lists the acronyms that are used in this document.

Table 34. Acronyms Used in this Datasheet

Acronym	Description	Acronym	Description
AC	alternating current	MIPS	million instructions per second
ADC	analog-to-digital converter	PCB	printed circuit board
API	application programming interface	PGA	programmable gain amplifier
CPU	central processing unit	PLL	phase-locked loop
CT	continuous time	POR	power on reset
DAC	digital-to-analog converter	PPOR	precision power on reset
DC	direct current	PSoC [®]	Programmable System-on-Chip
DTMF	dual-tone multi-frequency	PWM	pulse width modulator
ECO	external crystal oscillator	QFN	quad flat no leads
EEPROM	electrically erasable programmable read-only memory	RTC	real time clock
GPIO	general purpose I/O	SAR	successive approximation
ICE	in-circuit emulator	SC	switched capacitor
IDE	integrated development environment	SLIMO	slow IMO
ILO	internal low speed oscillator	SMP	switch-mode pump
IMO	internal main oscillator	SPI [™]	serial peripheral interface
I/O	input/output	SRAM	static random access memory
ISSP	in-system serial programming	SROM	supervisory read only memory
LCD	liquid crystal display	SSOP	shrink small-outline package
LPC	low power comparator	USB	universal serial bus
LVD	low voltage detect	WDT	watchdog timer
MAC	multiply-accumulate	XRES	external reset

Reference Documents

CY8CPLC20, CY8CLED16P01, CY8C29x66, CY8C27x43, CY8C24x94, CY8C24x23, CY8C24x23A, CY8C22x13, CY8C21x34, CY8C21x23, CY7C64215, CY7C603xx, CY8CNP1xx, and CYWUSB6953 PSoC[®] Programmable System-on-Chip Technical Reference Manual (TRM) (001-14463)

Understanding Datasheet Jitter Specifications for Cypress Timing Products – AN5054 (001-14503)

Application Notes for Surface Mount Assembly of Amkor's MicroLeadFrame (MLF) Packages – available at <http://www.amkor.com>.

Document Conventions

Units of Measure

Table 35 lists the units of measures.

Table 35. Units of Measure

Symbol	Unit of Measure	Symbol	Unit of Measure
kB	1024 bytes	μH	microhenry
dB	decibels	μs	microsecond
°C	degree Celsius	ms	millisecond
μF	microfarad	ns	nanosecond
fF	femto farad	ps	picosecond
pF	picofarad	μV	microvolts
kHz	kilohertz	mV	millivolts
MHz	megahertz	mVpp	millivolts peak-to-peak
rt-Hz	root hertz	nV	nanovolts
kΩ	kilohm	V	volts
Ω	ohm	μW	microwatts
μA	microampere	W	watt
mA	milliampere	mm	millimeter
nA	nanoampere	ppm	parts per million
pA	pikoampere	%	percent

Numeric Conventions

Hexadecimal numbers are represented with all letters in uppercase with an appended lowercase 'h' (for example, '14h' or '3Ah'). Hexadecimal numbers may also be represented by a '0x' prefix, the C coding convention. Binary numbers have an appended lowercase 'b' (for example, '01010100b' or '01000011b'). Numbers not indicated by an 'h' or 'b' are decimals.

Glossary

active high	<ol style="list-style-type: none"> 1. A logic signal having its asserted state as the logic 1 state. 2. A logic signal having the logic 1 state as the higher voltage of the two states.
analog blocks	The basic programmable opamp circuits. These are SC (switched capacitor) and CT (continuous time) blocks. These blocks can be interconnected to provide ADCs, DACs, multi-pole filters, gain stages, and much more.
analog-to-digital (ADC)	A device that changes an analog signal to a digital signal of corresponding magnitude. Typically, an ADC converts a voltage to a digital number. The digital-to-analog (DAC) converter performs the reverse operation.
API (Application Programming Interface)	A series of software routines that comprise an interface between a computer application and lower level services and functions (for example, user modules and libraries). APIs serve as building blocks for programmers that create software applications.
asynchronous	A signal whose data is acknowledged or acted upon immediately, irrespective of any clock signal.
bandgap reference	A stable voltage reference design that matches the positive temperature coefficient of VT with the negative temperature coefficient of VBE, to produce a zero temperature coefficient (ideally) reference.
bandwidth	<ol style="list-style-type: none"> 1. The frequency range of a message or information processing system measured in hertz. 2. The width of the spectral region over which an amplifier (or absorber) has substantial gain (or loss); it is sometimes represented more specifically as, for example, full width at half maximum.

Glossary *(continued)*

bias	<ol style="list-style-type: none"> 1. A systematic deviation of a value from a reference value. 2. The amount by which the average of a set of values departs from a reference value. 3. The electrical, mechanical, magnetic, or other force (field) applied to a device to establish a reference level to operate the device.
block	<ol style="list-style-type: none"> 1. A functional unit that performs a single function, such as an oscillator. 2. A functional unit that may be configured to perform one of several functions, such as a digital PSoC block or an analog PSoC block.
buffer	<ol style="list-style-type: none"> 1. A storage area for data that is used to compensate for a speed difference, when transferring data from one device to another. Usually refers to an area reserved for IO operations, into which data is read, or from which data is written. 2. A portion of memory set aside to store data, often before it is sent to an external device or as it is received from an external device. 3. An amplifier used to lower the output impedance of a system.
bus	<ol style="list-style-type: none"> 1. A named connection of nets. Bundling nets together in a bus makes it easier to route nets with similar routing patterns. 2. A set of signals performing a common function and carrying similar data. Typically represented using vector notation; for example, address[7:0]. 3. One or more conductors that serve as a common connection for a group of related devices.
clock	The device that generates a periodic signal with a fixed frequency and duty cycle. A clock is sometimes used to synchronize different logic blocks.
comparator	An electronic circuit that produces an output voltage or current whenever two input levels simultaneously satisfy predetermined amplitude requirements.
compiler	A program that translates a high level language, such as C, into machine language.
configuration space	In PSoC devices, the register space accessed when the XIO bit, in the CPU_F register, is set to '1'.
crystal oscillator	An oscillator in which the frequency is controlled by a piezoelectric crystal. Typically a piezoelectric crystal is less sensitive to ambient temperature than other circuit components.
cyclic redundancy check (CRC)	A calculation used to detect errors in data communications, typically performed using a linear feedback shift register. Similar calculations may be used for a variety of other purposes such as data compression.
data bus	A bi-directional set of signals used by a computer to convey information from a memory location to the central processing unit and vice versa. More generally, a set of signals used to convey data between digital functions.
debugger	A hardware and software system that allows the user to analyze the operation of the system under development. A debugger usually allows the developer to step through the firmware one step at a time, set break points, and analyze memory.
dead band	A period of time when neither of two or more signals are in their active state or in transition.
digital blocks	The 8-bit logic blocks that can act as a counter, timer, serial receiver, serial transmitter, CRC generator, pseudo-random number generator, or SPI.
digital-to-analog (DAC)	A device that changes a digital signal to an analog signal of corresponding magnitude. The analog-to-digital (ADC) converter performs the reverse operation.

Glossary (continued)

duty cycle	The relationship of a clock period high time to its low time, expressed as a percent.
emulator	Duplicates (provides an emulation of) the functions of one system with a different system, so that the second system appears to behave like the first system.
external reset (XRES)	An active high signal that is driven into the PSoC device. It causes all operation of the CPU and blocks to stop and return to a pre-defined state.
flash	An electrically programmable and erasable, non-volatile technology that provides users with the programmability and data storage of EPROMs, plus in-system erasability. Non-volatile means that the data is retained when power is off.
Flash block	The smallest amount of Flash ROM space that may be programmed at one time and the smallest amount of Flash space that may be protected. A Flash block holds 64 bytes.
frequency	The number of cycles or events per unit of time, for a periodic function.
gain	The ratio of output current, voltage, or power to input current, voltage, or power, respectively. Gain is usually expressed in dB.
I ² C	A two-wire serial computer bus by Philips Semiconductors (now NXP Semiconductors). I2C is an Inter-Integrated Circuit. It is used to connect low-speed peripherals in an embedded system. The original system was created in the early 1980s as a battery control interface, but it was later used as a simple internal bus system for building control electronics. I2C uses only two bi-directional pins, clock and data, both running at +5 V and pulled high with resistors. The bus operates at 100 kbits/second in standard mode and 400 kbits/second in fast mode.
ICE	The in-circuit emulator that allows users to test the project in a hardware environment, while viewing the debugging device activity in a software environment (PSoC Designer).
input/output (I/O)	A device that introduces data into or extracts data from a system.
interrupt	A suspension of a process, such as the execution of a computer program, caused by an event external to that process, and performed in such a way that the process can be resumed.
interrupt service routine (ISR)	A block of code that normal code execution is diverted to when the M8C receives a hardware interrupt. Many interrupt sources may each exist with its own priority and individual ISR code block. Each ISR code block ends with the RETI instruction, returning the device to the point in the program where it left normal program execution.
jitter	<ol style="list-style-type: none"> 1. A misplacement of the timing of a transition from its ideal position. A typical form of corruption that occurs on serial data streams. 2. The abrupt and unwanted variations of one or more signal characteristics, such as the interval between successive pulses, the amplitude of successive cycles, or the frequency or phase of successive cycles.
low-voltage detect (LVD)	A circuit that senses V _{dd} and provides an interrupt to the system when V _{dd} falls below a selected threshold.
M8C	An 8-bit Harvard-architecture microprocessor. The microprocessor coordinates all activity inside a PSoC by interfacing to the Flash, SRAM, and register space.
master device	A device that controls the timing for data exchanges between two devices. Or when devices are cascaded in width, the master device is the one that controls the timing for data exchanges between the cascaded devices and an external interface. The controlled device is called the slave device .

Glossary *(continued)*

microcontroller	An integrated circuit chip that is designed primarily for control systems and products. In addition to a CPU, a microcontroller typically includes memory, timing circuits, and IO circuitry. The reason for this is to permit the realization of a controller with a minimal quantity of chips, thus achieving maximal possible miniaturization. This in turn, reduces the volume and the cost of the controller. The microcontroller is normally not used for general-purpose computation as is a microprocessor.
mixed-signal	The reference to a circuit containing both analog and digital techniques and components.
modulator	A device that imposes a signal on a carrier.
noise	<ol style="list-style-type: none"> 1. A disturbance that affects a signal and that may distort the information carried by the signal. 2. The random variations of one or more characteristics of any entity such as voltage, current, or data.
oscillator	A circuit that may be crystal controlled and is used to generate a clock frequency.
parity	A technique for testing transmitting data. Typically, a binary digit is added to the data to make the sum of all the digits of the binary data either always even (even parity) or always odd (odd parity).
phase-locked loop (PLL)	An electronic circuit that controls an oscillator so that it maintains a constant phase angle relative to a reference signal.
pinouts	The pin number assignment: the relation between the logical inputs and outputs of the PSoC device and their physical counterparts in the printed circuit board (PCB) package. Pinouts involve pin numbers as a link between schematic and PCB design (both being computer generated files) and may also involve pin names.
port	A group of pins, usually eight.
power on reset (POR)	A circuit that forces the PSoC device to reset when the voltage is below a pre-set level. This is one type of hardware reset.
PSoC®	Cypress Semiconductor's PSoC® is a registered trademark and Programmable System-on-Chip™ is a trademark of Cypress.
PSoC Designer™	The software for Cypress' Programmable System-on-Chip technology.
pulse width modulator (PWM)	An output in the form of duty cycle which varies as a function of the applied measurand
RAM	An acronym for random access memory. A data-storage device from which data can be read out and new data can be written in.
register	A storage device with a specific capacity, such as a bit or byte.
reset	A means of bringing a system back to a know state. See hardware reset and software reset.
ROM	An acronym for read only memory. A data-storage device from which data can be read out, but new data cannot be written in.
serial	<ol style="list-style-type: none"> 1. Pertaining to a process in which all events occur one after the other. 2. Pertaining to the sequential or consecutive occurrence of two or more related activities in a single device or channel.
settling time	The time it takes for an output signal or value to stabilize after the input has changed from one value to another.

Glossary *(continued)*

shift register	A memory storage device that sequentially shifts a word either left or right to output a stream of serial data.
slave device	A device that allows another device to control the timing for data exchanges between two devices. Or when devices are cascaded in width, the slave device is the one that allows another device to control the timing of data exchanges between the cascaded devices and an external interface. The controlling device is called the master device.
SRAM	An acronym for static random access memory. A memory device allowing users to store and retrieve data at a high rate of speed. The term static is used because, after a value has been loaded into an SRAM cell, it remains unchanged until it is explicitly altered or until power is removed from the device.
SROM	An acronym for supervisory read only memory. The SROM holds code that is used to boot the device, calibrate circuitry, and perform Flash operations. The functions of the SROM may be accessed in normal user code, operating from Flash.
stop bit	A signal following a character or block that prepares the receiving device to receive the next character or block.
synchronous	<ol style="list-style-type: none">1. A signal whose data is not acknowledged or acted upon until the next active edge of a clock signal.2. A system whose operation is synchronized by a clock signal.
tri-state	A function whose output can adopt three states: 0, 1, and Z (high-impedance). The function does not drive any value in the Z state and, in many respects, may be considered to be disconnected from the rest of the circuit, allowing another output to drive the same net.
UART	A UART or universal asynchronous receiver-transmitter translates between parallel bits of data and serial bits.
user modules	Pre-build, pre-tested hardware/firmware peripheral functions that take care of managing and configuring the lower level Analog and Digital PSoC Blocks. User Modules also provide high level API (Application Programming Interface) for the peripheral function.
user space	The bank 0 space of the register map. The registers in this bank are more likely to be modified during normal program execution and not just during initialization. Registers in bank 1 are most likely to be modified only during the initialization phase of the program.
V _{DD}	A name for a power net meaning "voltage drain." The most positive power supply signal. Usually 5 V or 3.3 V.
V _{SS}	A name for a power net meaning "voltage source." The most negative power supply signal.
watchdog timer	A timer that must be serviced periodically. If it is not serviced, the CPU resets after a specified period of time.

Document History Page

Description Title: CY7C603xx, enCoRe™ III Low Voltage Document Number: 38-16018				
Rev.	ECN No.	Orig. of Change	Submission Date	Description of Change
**	339394	BON	See ECN	New Advance Data Sheet.
*A	399556	BHA	See ECN	Changed from Advance Information to Preliminary. Changed data sheet format. Removed CY7C604xx.
*B	461240	TYJ	See ECN	Modified Figure 10 to include 2.7 V Vdd at 12 MHz operation.
*C	470485	TYJ	See ECN	Corrected part numbers in section 4 to match with part numbers in Ordering Information. From CY7C60323-28PVXC, CY7C60323-56LFXC and CY7C60333-56LFXC to CY7C60323-PVXC, CY7C60323-LFXC and CY7C60333-LFXC respectively. Changed from Preliminary to Final data sheet.
*D	513713	KKV/TMP	See ECN	Change title from Wireless enCoRe II to enCoRe III Low Voltage. Applied new template formatting.
*E	2197567	UVS/AESA	See ECN	Added 32-Pin Sawn QFN Pin Diagram, package diagram, and ordering information.
*F	2620679	CMCC/PYRS	12/12/2008	Added Packaging Handling information. Deleted note regarding link to amkor.com for MLF package dimensions.
*G	2852393	XUT	01/15/2010	Added Table of Contents . Updated DC GPIO, AC Chip-Level, and AC Programming Specifications as follows: Replaced TRAMP (time) with SRPOWER_UP (slew rate) specification. Added I _{OH} , I _{OL} , DCILO, F32K_U, TPOWERUP, TERASEALL, TPROGRAM_HOT, and TPROGRAM_COLD specifications. Updated copyright and Sales, Solutions, and Legal Information URLs. Updated 28-Pin SSOP and 32-Pin QFN (PUNCH and SAWN) package diagrams.
*H	2892683	NJF	03/15/2010	Updated Cypress website links. Updated Development Kits . Updated 3.3 V AC Chip-Level Specifications and 2.7 V AC Chip-Level Specifications . Removed AC Analog Mux Bus Specs section. Updated 32-pin Sawn QFN package diagram. Removed inactive parts from Ordering Information .
*I	2911952	GNKK	04/13/2010	Updated revision in the footer.
*J	3014656	BHA	09/15/2010	Updated Logic Block Diagram to enCore III LV. Added Ordering Code Definitions Added Acronyms and Units of Measure table. Datasheet updated as per latest Template.
*K	3114976	NJF	12/19/10	Updated 3.3-V and 2.7-V AC Digital Block Specifications. Updated DC Operational Amplifier Specifications. Updated I ² C Timing Diagram. Added DC I ² C Specifications. Added UILO max limit. Added Tjit_IMO specification, removed existing jitter specifications. Updated Units of Measure, Acronyms, Glossary, and References sections. Updated solder reflow specifications.
*L	3180466	CSAI	02/23/2011	Updated Packaging Information . Updated in new template.

Sales, Solutions, and Legal Information

Worldwide Sales and Design Support

Cypress maintains a worldwide network of offices, solution centers, manufacturer's representatives, and distributors. To find the office closest to you, visit us at [Cypress Locations](#).

Products

Automotive	cypress.com/go/automotive
Clocks & Buffers	cypress.com/go/clocks
Interface	cypress.com/go/interface
Lighting & Power Control	cypress.com/go/powerpsoc cypress.com/go/plc
Memory	cypress.com/go/memory
Optical & Image Sensing	cypress.com/go/image
PSoC	cypress.com/go/psoc
Touch Sensing	cypress.com/go/touch
USB Controllers	cypress.com/go/USB
Wireless/RF	cypress.com/go/wireless

PSoC® Solutions

psoc.cypress.com/solutions
PSoC 1 | PSoC 3 | PSoC 5

© Cypress Semiconductor Corporation, 2005-2011. The information contained herein is subject to change without notice. Cypress Semiconductor Corporation assumes no responsibility for the use of any circuitry other than circuitry embodied in a Cypress product. Nor does it convey or imply any license under patent or other rights. Cypress products are not warranted nor intended to be used for medical, life support, life saving, critical control or safety applications, unless pursuant to an express written agreement with Cypress. Furthermore, Cypress does not authorize its products for use as critical components in life-support systems where a malfunction or failure may reasonably be expected to result in significant injury to the user. The inclusion of Cypress products in life-support systems application implies that the manufacturer assumes all risk of such use and in doing so indemnifies Cypress against all charges.

Any Source Code (software and/or firmware) is owned by Cypress Semiconductor Corporation (Cypress) and is protected by and subject to worldwide patent protection (United States and foreign), United States copyright laws and international treaty provisions. Cypress hereby grants to licensee a personal, non-exclusive, non-transferable license to copy, use, modify, create derivative works of, and compile the Cypress Source Code and derivative works for the sole purpose of creating custom software and or firmware in support of licensee product to be used only in conjunction with a Cypress integrated circuit as specified in the applicable agreement. Any reproduction, modification, translation, compilation, or representation of this Source Code except as specified above is prohibited without the express written permission of Cypress.

Disclaimer: CYPRESS MAKES NO WARRANTY OF ANY KIND, EXPRESS OR IMPLIED, WITH REGARD TO THIS MATERIAL, INCLUDING, BUT NOT LIMITED TO, THE IMPLIED WARRANTIES OF MERCHANTABILITY AND FITNESS FOR A PARTICULAR PURPOSE. Cypress reserves the right to make changes without further notice to the materials described herein. Cypress does not assume any liability arising out of the application or use of any product or circuit described herein. Cypress does not authorize its products for use as critical components in life-support systems where a malfunction or failure may reasonably be expected to result in significant injury to the user. The inclusion of Cypress' product in a life-support systems application implies that the manufacturer assumes all risk of such use and in doing so indemnifies Cypress against all charges.

Use may be limited by and subject to the applicable Cypress software license agreement.