

NHD-12232AZ-FSW-GBW

Graphic Liquid Crystal Display Module

NHD-	Newhaven Display
12232-	122 x 32 pixels
AZ-	Model
F-	Transflective
SW-	Side White LED Backlight
G-	STN- Gray
B-	6:00 view
W-	Wide Temperature (-20°C ~+70°C)

RoHS Compliant

Newhaven Display International, Inc.

2511 Technology Drive, Suite 101

Elgin IL, 60124

Ph: 847-844-8795

Fax: 847-844-8796

www.newhavendisplay.com

nhtech@newhavendisplay.com

nhsales@newhavendisplay.com

Document Revision History

Revision	Date	Description	Changed by
0	10/22/2008	Initial Release	-
1	3/16/2010	User guide reformat	BE
2	4/15/2010	Controller update	BE
3	8/5/2010	Electrical Characteristics Update	MP

Functions and Features

- 122 x 32 pixels
- Built-in SBN1661G_M02 Controller
- +5.0V power supply
- 1/32 duty cycle; 1/9 bias
- RoHS Compliant

Pin Description and Wiring Diagram

Pin No.	Symbol	External Connection	Function Description
1	VSS	Power Supply	Ground
2	VDD	Power Supply	Power supply for logic (+5.0V)
3	V0	Adj Power Supply	Power supply for contrast (approx.- 1.5V)
4	RST	MPU	Active LOW Reset signal
5	E1	MPU	Operation enable signal. Falling edge triggered, SEG (1~60)
6	E2	MPU	Operation enable signal. Falling edge triggered, SEG (61~120)
7	R/W	MPU	Read/Write select signal, R/W=1: Read R/W: =0: Write
8	A0	MPU	Register select signal. A0=0: Command, A0=1: Data
9-16	DB0-DB7	MPU	This is an 8-bit bi-directional data bus
17	LED+	Power Supply	Power supply for LED Backlight (+5.0V via on-board resistor)
18	LED-	Power Supply	Ground for Backlight

Recommended LCD connector: 2.54mm pitch pins

Backlight connector: - Mates with: -

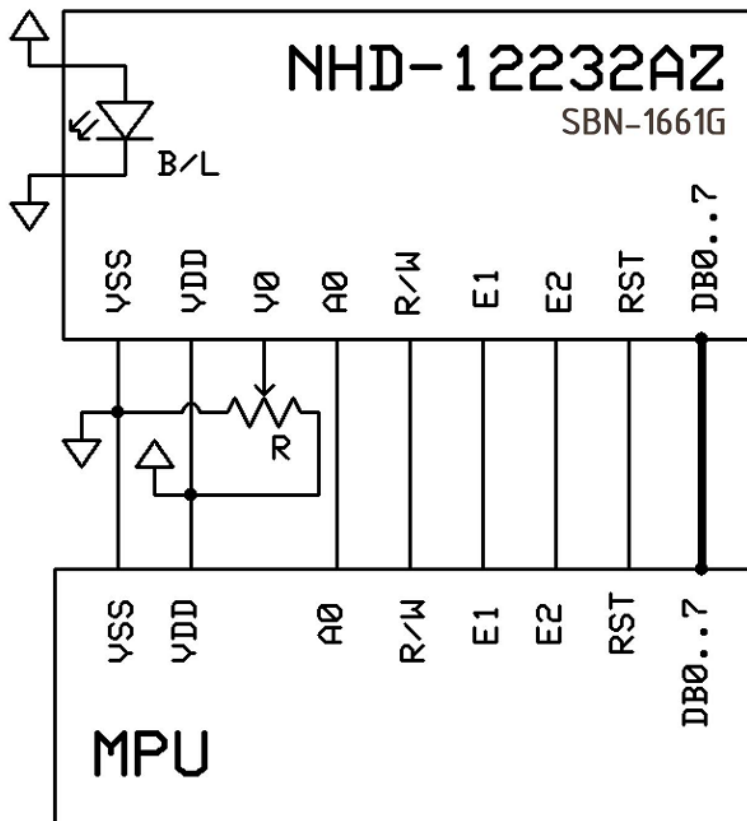

Electrical Characteristics

Item	Symbol	Condition	Min.	Typ.	Max.	Unit
Operating Temperature Range	Top	Absolute Max	-20	-	+70	°C
Storage Temperature Range	Tst	Absolute Max	-30	-	+80	°C
Supply Voltage	VDD		4.7	5.0	5.5	V
Supply Current	IDD	Ta=25°C, VDD=5.0V	-	2.0	3.0	mA
Supply for LCD (contrast)	VDD-V0	Ta=25°C	-	6.5	-	V
"H" Level input	VIH		0.7*VDD	0.7*VDD	VDD	V
"L" Level input	VIL	-	0	-	0.6	V
"H" Level output	VOH	-	2.4	-	-	V
"L" Level output	VOL	-	-	-	0.4	V
Backlight Supply Voltage	VLED		-	5.0	-	V
Backlight Supply Current	ILED	VLED=5.0V	-	18	-	mA

Optical Characteristics

Item	Symbol	Condition	Min.	Typ.	Max.	Unit
Viewing Angle - Vertical (top)	AV	Cr ≥ 3	-	10	-	
Viewing Angle – Vertical (bottom)	AV	Cr ≥ 3	-	60	-	°
Viewing Angle – Horizontal (left)	AH	Cr ≥ 3	-	45	-	
Viewing Angle - Horizontal (right)	AH	Cr ≥ 3	-	45	-	°
Contrast Ratio	Cr		-	5	-	-
Response Time (rise)	Tr	-	-	100	150	ms
Response Time (fall)	Tf	-	-	150	200	ms

Controller Information

Built-in SBN1661G_M02. Download specification at http://www.newhavendisplay.com/app_notes/SBN1661G.pdf

Table of Commands

COMMAND	COMMAND CODE								FUNCTION
	D7	D6	D5	D4	D3	D2	D1	D0	
Write Display Data	Data to be written into the Display Data Memory.								Write a byte of data to the Display Data Memory.
Read Display Data	Data read from the Display Data Memory.								Read a byte of data from the Display Data Memory.
Read-Modify-Write	1	1	1	0	0	0	0	0	Start Read-Modify-Write operation.
END	1	1	1	0	1	1	1	0	Stop Read-Modify-Write operation.
Software Reset	1	1	1	0	0	0	1	0	Software Reset.

Timing Characteristics

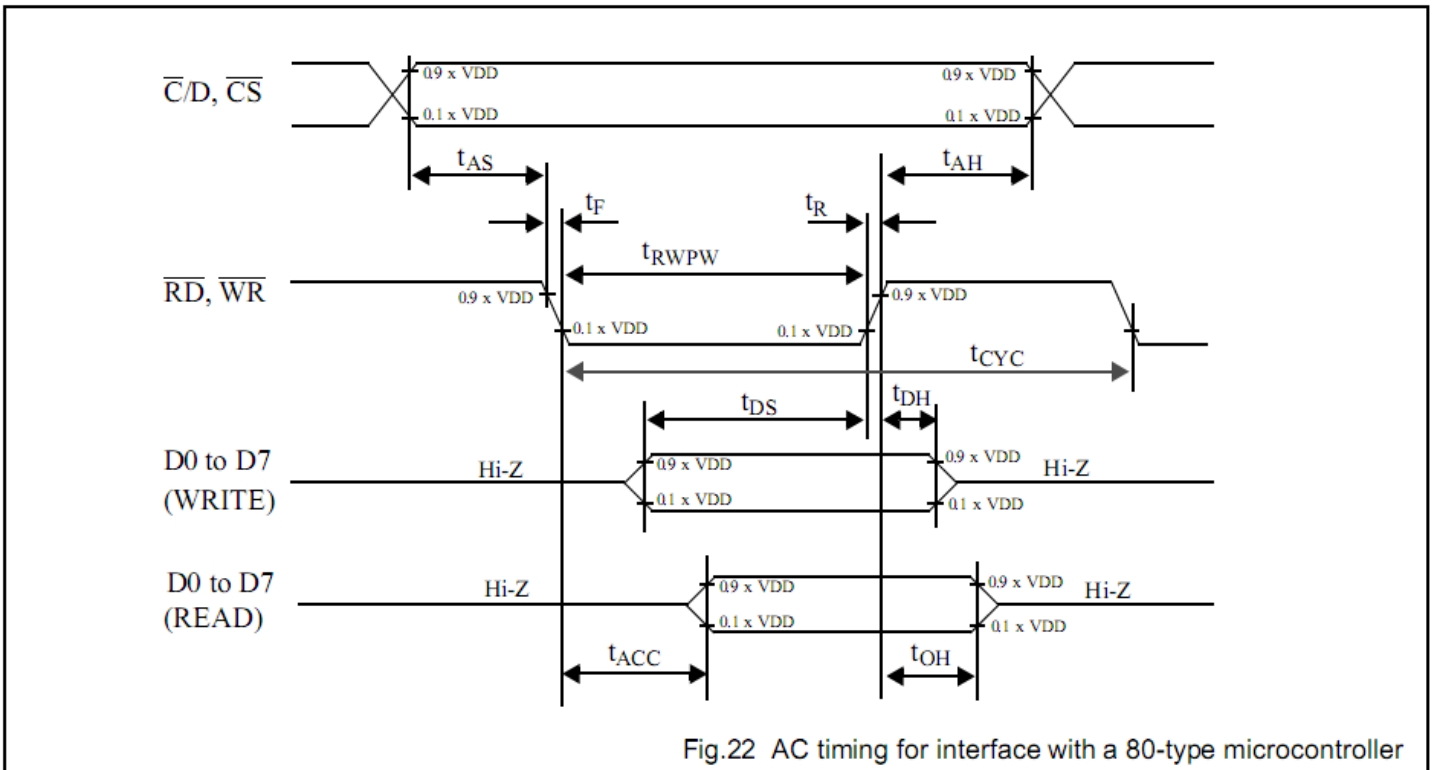

$V_{DD} = 5\text{ V} \pm 10\%$; $V_{SS} = 0\text{ V}$; $T_{amb} = -20\text{ }^{\circ}\text{C}$ to $+75\text{ }^{\circ}\text{C}$.

symbol	parameter	min.	max.	test conditons	unit
t_{AS}	Address set-up time	20			ns
t_{AH}	Address hold time	10			ns
t_F, t_R	Read/Write pulse falling/rising time		15		ns
t_{RWPW}	Read/Write pulse width	200			ns
t_{CYC}	System cycle time	1000			ns
t_{DS}	Data setup time	80			ns
t_{DH}	Data hold time	10			ns
t_{ACC}	Data READ access time		90	CL= 100 pF.	ns
t_{OH}	Data READ output hold time	10	60	Refer to Fig. 23.	ns

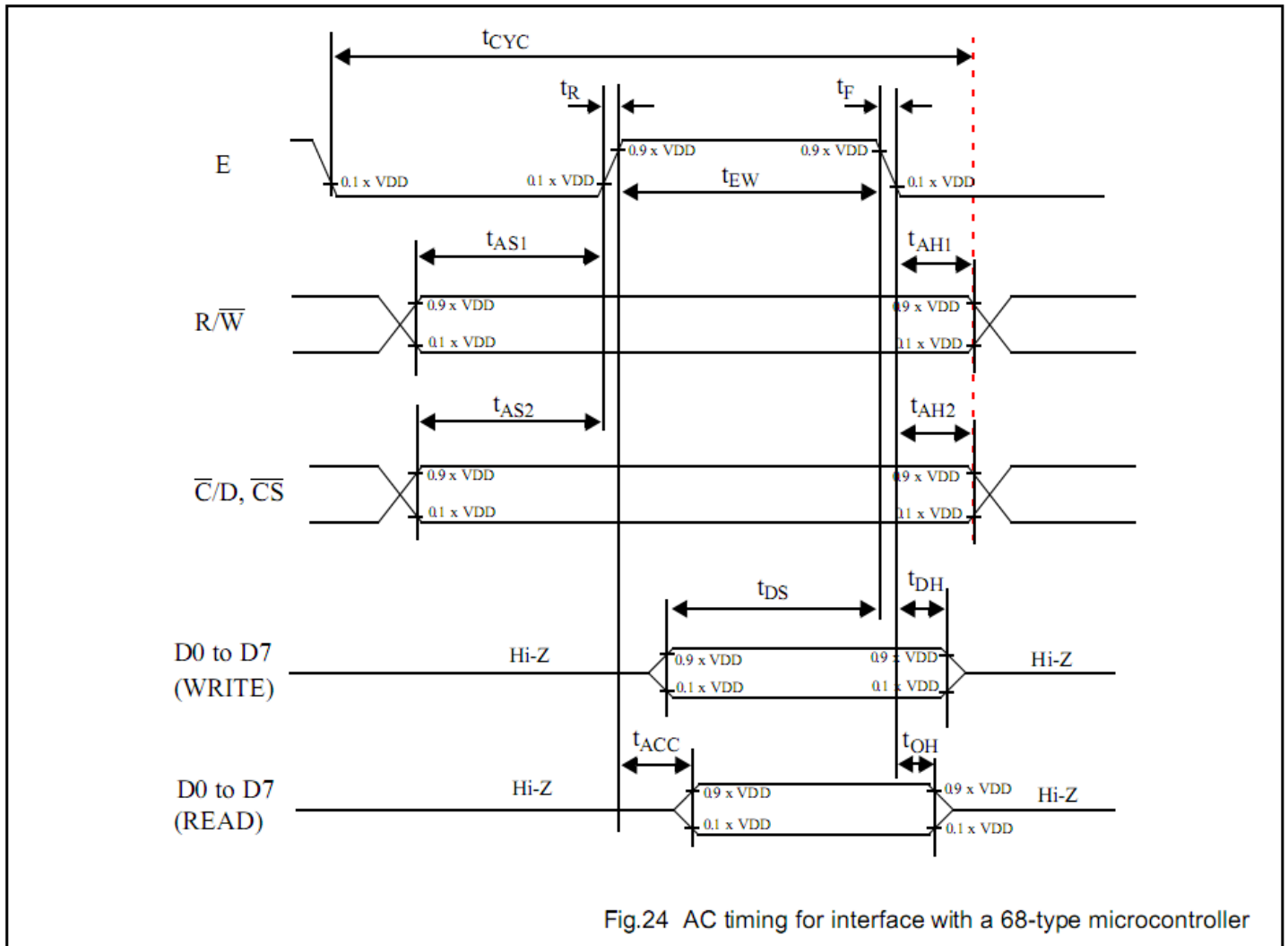

$V_{DD} = 5 V \pm 10\%$; $V_{SS} = 0 V$; $T_{amb} = -20^{\circ}C$ to $+75^{\circ}C$.

symbol	parameter	min.	max.	test conditons	unit
t_{AS1}	Address set-up time with respect to R/\overline{W}	20			ns
t_{AS2}	Address set-up time with respect to $\overline{C/D}, \overline{CS}$	20			ns
t_{AH1}	Address hold time with respect to R/\overline{W}	10			ns
t_{AH2}	Address hold time respect with to $\overline{C/D}, \overline{CS}$	10			ns
t_F, t_R	Enable (E) pulse falling/rising time		15		ns
t_{CYC}	System cycle time	1000		Note 1	ns
t_{EWR}	Enable pulse width for READ	100			ns
t_{EWW}	Enable pulse width for WRITE	80			ns
t_{DS}	Data setup time	80			ns
t_{DH}	Data hold time	10			ns
t_{ACC}	Data access time		90	$CL = 100$ pF.	ns
t_{OH}	Data output hold time	10	60	Refer to Fig. 23.	ns

Example Initialization Program:

```
/******  
void Comleft(char i)  
{  
  P1 = i;  
  R_W = 0;  
  D_I = 0;  
  E1 = 1;  
  delay(2);  
  E1 = 0;  
}  
  
void Comright(char i)  
{  
  P1 = i;  
  R_W = 0;  
  D_I = 0;  
  E2 = 1;  
  delay(2);  
  E2 = 0;  
}  
  
void Writeleft(char i)  
{  
  P1 = i;  
  R_W = 0;  
  D_I = 1;  
  E1 = 1;  
  delay(2);  
  E1 = 0;  
}  
  
void Writerright(char i)  
{  
  P1 = i;  
  R_W = 0;  
  D_I = 1;  
  E2 = 1;  
  delay(2);  
  E2 = 0;  
}  
/******  
void bothSides(char i)  
{  
  Comleft(i);  
  Comright(i);  
}  
/******  
  
void init()  
{  
  P1 = 0;  
  P3 = 0;  
  RST = 0; //      Reset RST  
  delay(1);  
  RST = 1; //      Reset RST= M68 Interface  
  delay(10);  
  D_I = 0;  
  E1 = 1;  
  E2 = 1;  
  R_W = 1;  
  
  bothSides(0xE2);  
  delay(10);  
  bothSides(0xA4);  
  bothSides(0xA9);  
  bothSides(0xA0);  
  bothSides(0xEE);  
  bothSides(0xC0);  
  bothSides(0xAF);  
}  
/******
```

Quality Information

Test Item	Content of Test	Test Condition	Note
High Temperature storage	Endurance test applying the high storage temperature for a long time.	+80°C , 200hrs	2
Low Temperature storage	Endurance test applying the low storage temperature for a long time.	-30°C , 200hrs	1,2
High Temperature Operation	Endurance test applying the electric stress (voltage & current) and the high thermal stress for a long time.	+70°C 200hrs	2
Low Temperature Operation	Endurance test applying the electric stress (voltage & current) and the low thermal stress for a long time.	-20°C , 200hrs	1,2
High Temperature / Humidity Operation	Endurance test applying the electric stress (voltage & current) and the high thermal with high humidity stress for a long time.	+60°C , 90% RH , 96hrs	1,2
Thermal Shock resistance	Endurance test applying the electric stress (voltage & current) during a cycle of low and high thermal stress.	-20°C,30min -> 25°C,5min -> 70°C,30min = 1 cycle 10 cycles	
Vibration test	Endurance test applying vibration to simulate transportation and use.	10-55Hz , 15mm amplitude. 60 sec in each of 3 directions X,Y,Z For 15 minutes	3
Static electricity test	Endurance test applying electric static discharge.	VS=800V, RS=1.5kΩ, CS=100pF One time	

Note 1: No condensation to be observed.

Note 2: Conducted after 4 hours of storage at 25°C, 0%RH.

Note 3: Test performed on product itself, not inside a container.

Precautions for using LCDs/LCMs

See Precautions at www.newhavendisplay.com/specs/precautions.pdf

Warranty Information and Terms & Conditions

http://www.newhavendisplay.com/index.php?main_page=terms