

Extended Power IR Emitting Diode in SMD Package

Description

TSML1000 series are high efficiency infrared emitting diodes in GaAlAs on GaAs technology molded in clear SMD package.

This technology represents best performance for radiant power under pulse conditions, forward voltage and reliability.

Features

- Outstanding high radiant power
- Low forward voltage
- Suitable for high pulse current operation
- Angle of half intensity $\phi = \pm 12^\circ$
- Peak wavelength $\lambda_p = 950 \text{ nm}$
- High reliability
- Matched Phototransistor series: TEMT1000
- Versatile terminal configurations

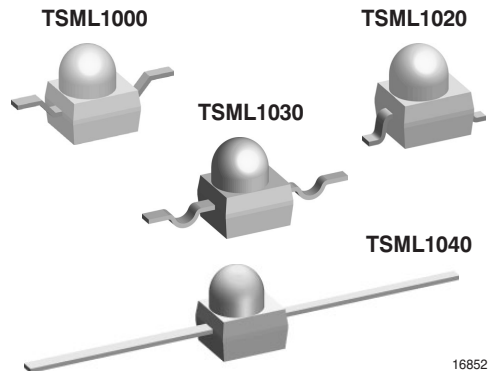

Applications

For remote control
 Photointerrupters
 Punched tape readers
 Encoder

Absolute Maximum Ratings

$T_{amb} = 25^\circ\text{C}$, unless otherwise specified

| Parameter | Test condition | Symbol | Value | Unit |
|-------------------------------------|--------------------------------------|------------|---------------|------------------|
| Reverse Voltage | | V_R | 5 | V |
| Forward Current | | I_F | 100 | mA |
| Peak Forward Current | $t_p/T = 0.5, t_p = 100 \mu\text{s}$ | I_{FM} | 200 | mA |
| Surge Forward Current | $t_p = 100 \mu\text{s}$ | I_{FSM} | 1.0 | A |
| Power Dissipation | | P_V | 190 | mW |
| Junction Temperature | | T_j | 100 | $^\circ\text{C}$ |
| Operating Temperature Range | | T_{amb} | - 40 to + 85 | $^\circ\text{C}$ |
| Storage Temperature Range | | T_{stg} | - 40 to + 100 | $^\circ\text{C}$ |
| Soldering Temperature | $t \leq 5\text{sec}$ | T_{sd} | <260 | $^\circ\text{C}$ |
| Thermal Resistance Junction/Ambient | | R_{thJA} | 400 | $^\circ\text{C}$ |

Basic Characteristics

$T_{amb} = 25^\circ\text{C}$, unless otherwise specified

$T_{amb} = 25^\circ\text{C}$, unless otherwise specified

| Parameter | Test condition | Symbol | Min | Typ. | Max | Unit |
|----------------------------|-----------------------------------------------|-----------|-----|--------|-----|---------------|
| Forward Voltage | $I_F = 20 \text{ mA}, t_p = 20 \text{ ms}$ | V_F | | 1.2 | 1.5 | V |
| | $I_F = 1 \text{ A}, t_p = 100 \mu\text{s}$ | V_F | | 2.6 | | V |
| Temp. Coefficient of V_F | $I_F = 1 \text{ mA}$ | TK_{VF} | | - 1.85 | | mV/K |
| Reverse Current | $V_R = 5 \text{ V}$ | I_R | | | 10 | μA |
| Junction Capacitance | $V_R = 0 \text{ V}, f = 1 \text{ MHz}, E = 0$ | C_j | | 25 | | pF |
| Radiant Intensity | $I_F = 20 \text{ mA}, t_p = 20 \text{ ms}$ | I_e | 3 | 7 | | mW/sr |

| Parameter | Test condition | Symbol | Min | Typ. | Max | Unit |
|----------------------------------|------------------------------------------------|------------------|-----|----------|-----|------|
| Radiant Power | $I_F = 100 \text{ mA}$, $t_p = 20 \text{ ms}$ | ϕ_e | | 35 | | mW |
| Temp. Coefficient of ϕ_e | $I_F = 20 \text{ mA}$ | TK_{ϕ_e} | | - 0.6 | | %/K |
| Angle of Half Intensity | | ϕ | | ± 12 | | deg |
| Peak Wavelength | $I_F = 100 \text{ mA}$ | λ_p | | 950 | | nm |
| Spectral Bandwidth | $I_F = 100 \text{ mA}$ | $\Delta\lambda$ | | 50 | | nm |
| Temp. Coefficient of λ_p | $I_F = 100 \text{ mA}$ | TK_{λ_p} | | 0.2 | | nm/K |
| Rise Time | $I_F = 100 \text{ mA}$ | t_r | | 800 | | ns |
| Fall Time | $I_F = 100 \text{ mA}$ | t_f | | 800 | | ns |

Typical Characteristics ($T_{amb} = 25 \text{ }^\circ\text{C}$ unless otherwise specified)

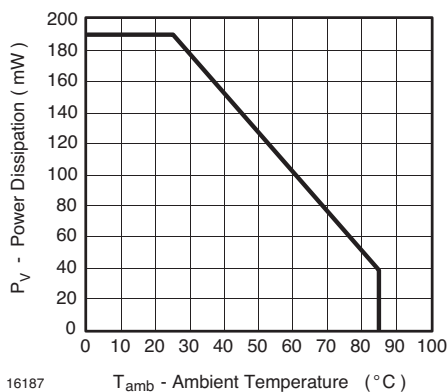

Figure 1. Power Dissipation vs. Ambient Temperature

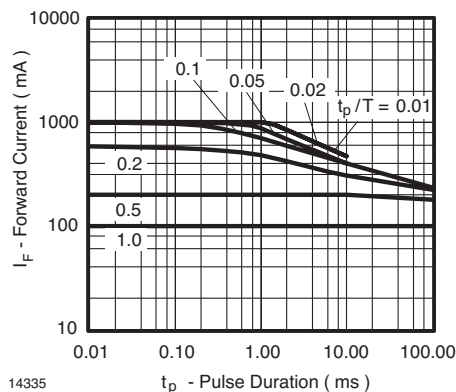

Figure 3. Pulse Forward Current vs. Pulse Duration

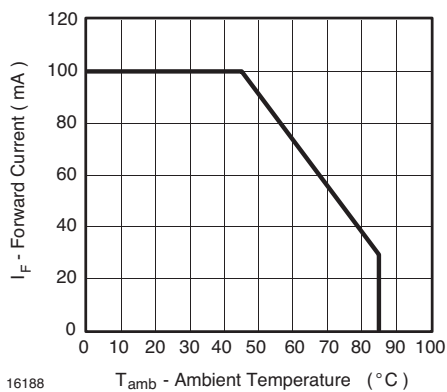

Figure 2. Forward Current vs. Ambient Temperature

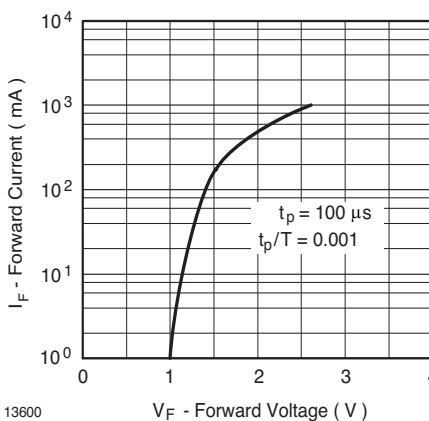

Figure 4. Forward Current vs. Forward Voltage

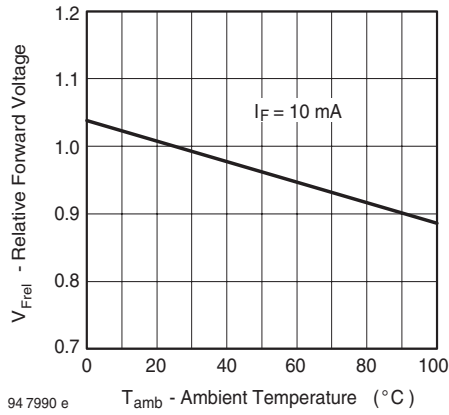

Figure 5. Relative Forward Voltage vs. Ambient Temperature

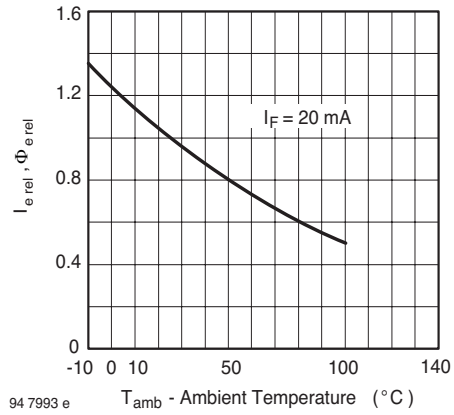

Figure 8. Rel. Radiant Intensity/Power vs. Ambient Temperature

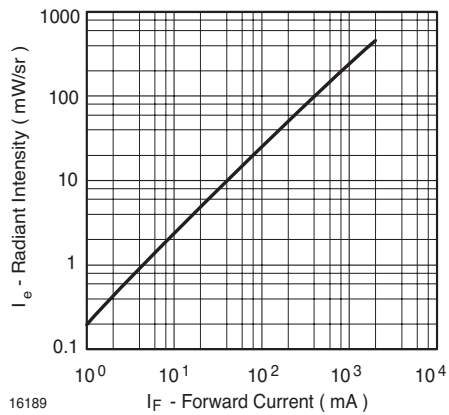

Figure 6. Radiant Intensity vs. Forward Current

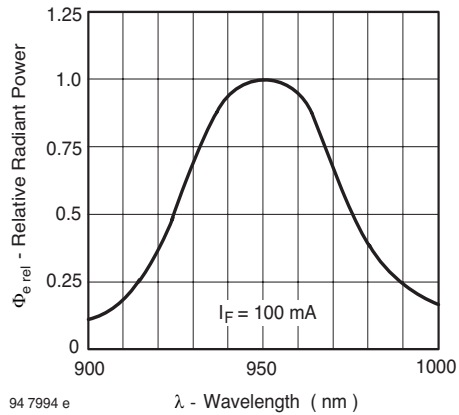

Figure 9. Relative Radiant Power vs. Wavelength

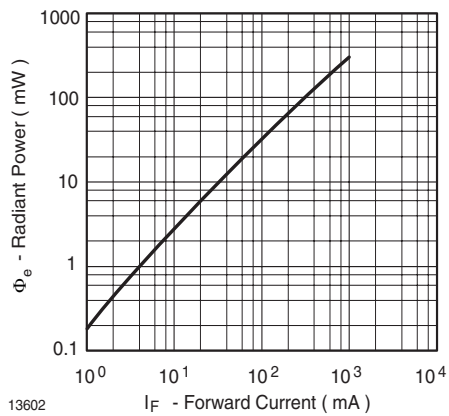

Figure 7. Radiant Power vs. Forward Current

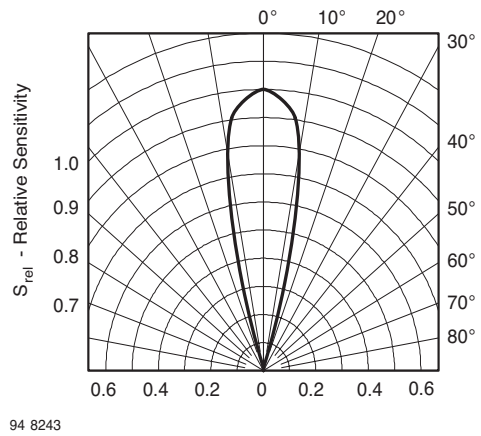

Figure 10. Relative Radiant Sensitivity vs. Angular Displacement

TSML1000/1020/1030/1040



Vishay Semiconductors

Package Dimensions in mm TSML1000

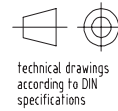
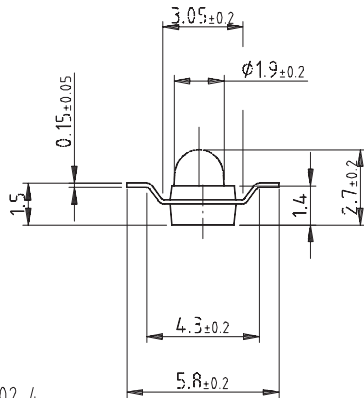

technical drawings
according to DIN
specifications

All dimensions in mm

Drawing-No.: 6.544-5326.02-4
Issue: 3; 02.04.03

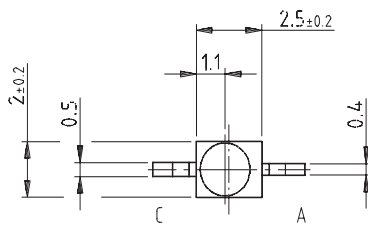

Solder pad proposal

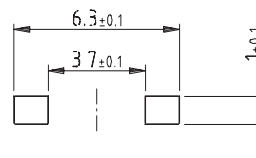

16159

Package Dimensions in mm TSML1020

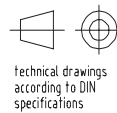
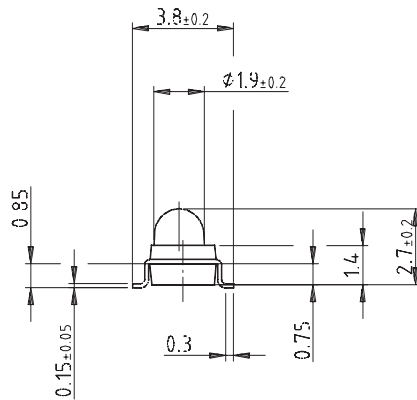

technical drawings
according to DIN
specifications

All dimensions in mm

Drawing-No.: 6.544-5325.02-4
Issue: 3; 02.04.03

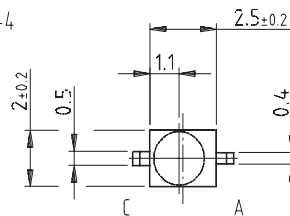

Solder pad proposal

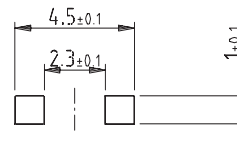

16160

Package Dimensions in mm
TSML1030

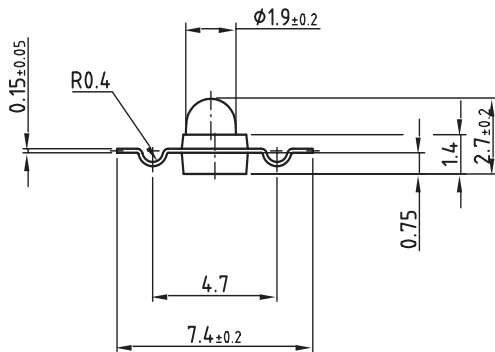

Drawing-No.: 6.544-5329.01-4
Issue: 4; 08.05.03



All dimensions in mm

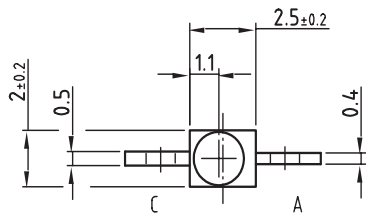

Solder pad proposal

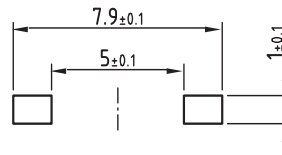

16228

Package Dimensions in mm
TSML1040

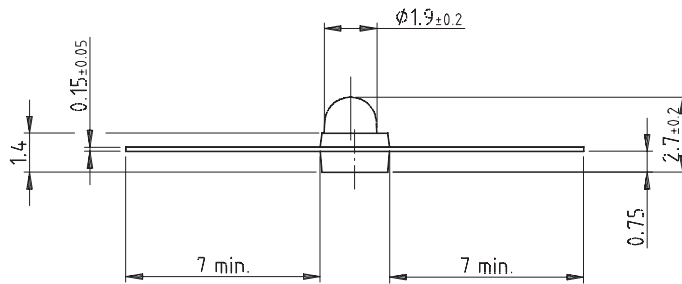

Drawing-No.: 6.544-5339.02-4
Issue: 3; 02.04.03

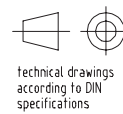

All dimensions in mm

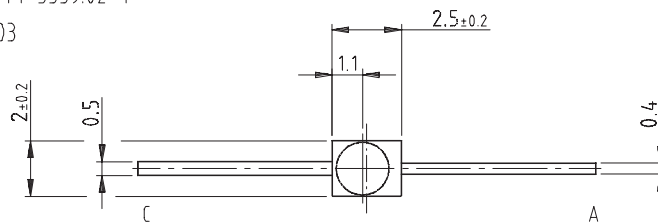

16760

TSML1000/1020/1030/1040



Vishay Semiconductors

Reel Dimensions

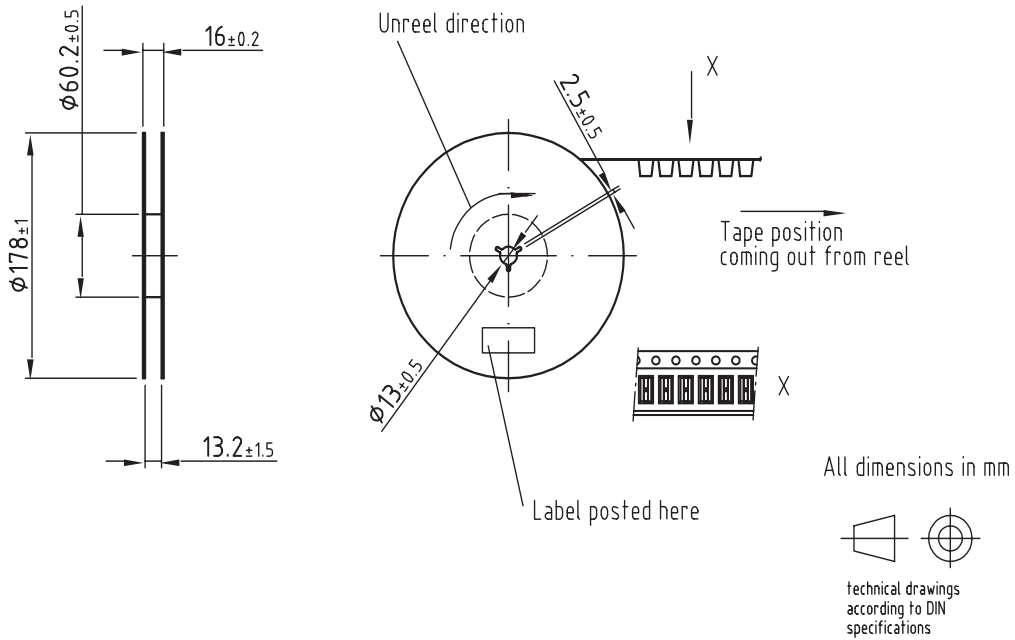

Leader and trailer tape:

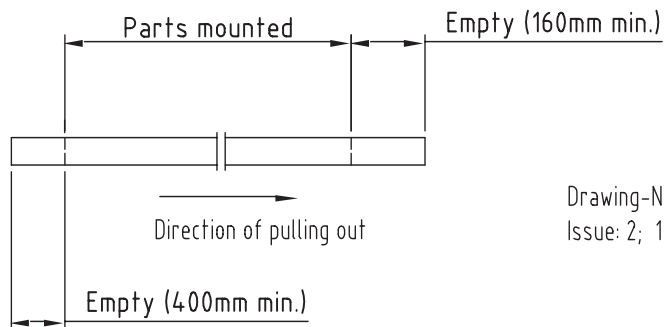

Drawing-No.: 9.800-5080.01-4
Issue: 2; 18.11.02

18033

Taping TSML1030

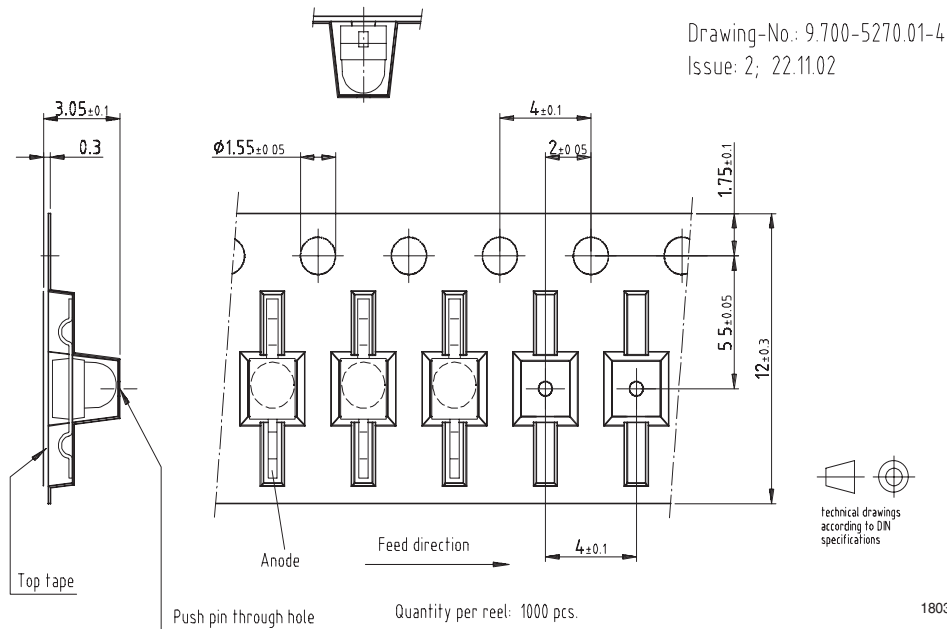

Precautions For Use

1. Over-current-proof

Customer must apply resistors for protection, otherwise slight voltage shift will cause big current change (Burn out will happen).

2. Storage

2.1 Storage temperature and rel. humidity conditions are: 5°C to 35°C , R.H. 60%

2.2 Floor life must not exceed 168 h, acc. to JEDEC level 3, J-STD-020.

Once the package is opened, the products should be used within a week. Otherwise, they should be kept in a damp proof box with desiccant.

Considering tape life, we suggest to use products within one year from production date.

2.3 If opened more than one week in an atmosphere 5°C to 35°C , R.H. 60%, devices should be treated at $60^{\circ}\text{C} \pm 5^{\circ}\text{C}$ for 15 hrs.

2.4 If humidity indicator in the package shows pink color (normal blue), then devices should be treated with the same conditions as 2.3

Reflow Solder Profile

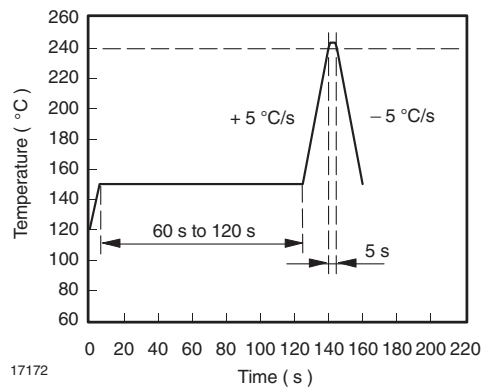



Ozone Depleting Substances Policy Statement

It is the policy of **Vishay Semiconductor GmbH** to

1. Meet all present and future national and international statutory requirements.
2. Regularly and continuously improve the performance of our products, processes, distribution and operating systems with respect to their impact on the health and safety of our employees and the public, as well as their impact on the environment.

It is particular concern to control or eliminate releases of those substances into the atmosphere which are known as ozone depleting substances (ODSs).

The Montreal Protocol (1987) and its London Amendments (1990) intend to severely restrict the use of ODSs and forbid their use within the next ten years. Various national and international initiatives are pressing for an earlier ban on these substances.

Vishay Semiconductor GmbH has been able to use its policy of continuous improvements to eliminate the use of ODSs listed in the following documents.

1. Annex A, B and list of transitional substances of the Montreal Protocol and the London Amendments respectively
2. Class I and II ozone depleting substances in the Clean Air Act Amendments of 1990 by the Environmental Protection Agency (EPA) in the USA
3. Council Decision 88/540/EEC and 91/690/EEC Annex A, B and C (transitional substances) respectively.

Vishay Semiconductor GmbH can certify that our semiconductors are not manufactured with ozone depleting substances and do not contain such substances.

**We reserve the right to make changes to improve technical design
and may do so without further notice.**

Parameters can vary in different applications. All operating parameters must be validated for each customer application by the customer. Should the buyer use Vishay Semiconductors products for any unintended or unauthorized application, the buyer shall indemnify Vishay Semiconductors against all claims, costs, damages, and expenses, arising out of, directly or indirectly, any claim of personal damage, injury or death associated with such unintended or unauthorized use.

Vishay Semiconductor GmbH, P.O.B. 3535, D-74025 Heilbronn, Germany
Telephone: 49 (0)7131 67 2831, Fax number: 49 (0)7131 67 2423