

12 Watt DC-DC Converters

KEY FEATURES

- Wide Input Range: 4:1
- Efficiencies 78-82% Typical
- L-C Input Filter
- Overload/Short Circuit Protection,
- Overvoltage Protection (Output)
- Low Profile: 0.375" High (10mm)
- No Derating to 71 °C
- 2000V Isolation
- Designed to meet UL60950



APPLICATIONS

- Telecommunications Equipment
- Industrial Control Systems
- Digital Circuits
- Analog Systems
- Private Branch Exchange (PBX, PABX)
- Distributed Power Systems

The 12AW series of DC/DC converters operate from a nominal 24 or 48 VDC input source. This series is available in 5 volt & 3.3 volt single output and a dual + & - 12 volt output models. Maximum output power is 12 watts. These board mountable, low profile DC/DC converters are ideal for the requirements of the industrial control and telecommunications industries.

The size and pin out conform to internationally recognised packaging that is an industry standard. Operating from a nominal 24 or 48 VDC input source, this PCB mountable, low profile miniature converter provides single regulated, isolated outputs of 5 & 3.3 VDC or a dual regulated, isolated output of ± 12 VDC. It is designed to meet a variety of safety and emissions requirements including CE (LVD), EN 55022 "Class A", and UL60950.

Selection Guide

Device Type	Input Voltage Range VDC	Input Current A (Max)	Output Voltage VDC	Output Current A (Max)	Package/ Pinout
12AW48R3.3	18 – 72	.319A	+ or - 3.3	3.64	A
12AW48R5	18 – 72	.304A	+ or - 5	2.40	A
12AW48R12-12	18 – 72	.325A	+ and - 12	0.50	A

General Electrical Specifications

(Specifications at Nominal Input and 25 C, nominal input voltage and rated output current unless otherwise noted.)

Parameter	Limit	Conditions
Input Voltage Range	18 - 72 VDC	24V & 48V Input Devices
Input Filter	L-C Section	
Input Ripple Current	50 mA P-P	Typical
Input/Output Isolation	2000 VDC	
Output Voltage Accuracy	2%	Full Load Nominal Line
Minimum Load	10% of Full Load	
Output Noise: All Units	100 mV P-P (Max)	20 MHz Bandwidth, 0.1µF capacitor on the output
Line Regulation: Singles	0.5%	Full Load
Load Regulation: Singles	0.5%	10% to 100% of Full Load
Efficiency	80%	Typical
Operating Temperature	-25°C to +71°C	No Derating
Storage Temperature	-55°C to 125°C	
Short Circuit Protection	Continuous	
Overvoltage Protection	4.3 VDC 6.2 VDC 30 VDC	3.3 VDC Output 5.0 VDC Output 12 VDC Output
Temperature Coefficient	.02% per °C	

Pin Connections:

Pin	Single Output	Dual Output
1	+ V Input	+ V Input
2	- V Input	- V Input
3	+ V Output	+ V Output
4	No pin/Adjust (5V only)*	Output Common
5	V Return	- V Output

*5V output model may be ordered with adjust pin 4 (trim) by adding the suffix " T "

Notes (all devices and packages):

- All dimensions in parentheses are metric
- Tolerances unless otherwise specified:
.xx ± .03 (.76)
.xxx ± .015 (.38)

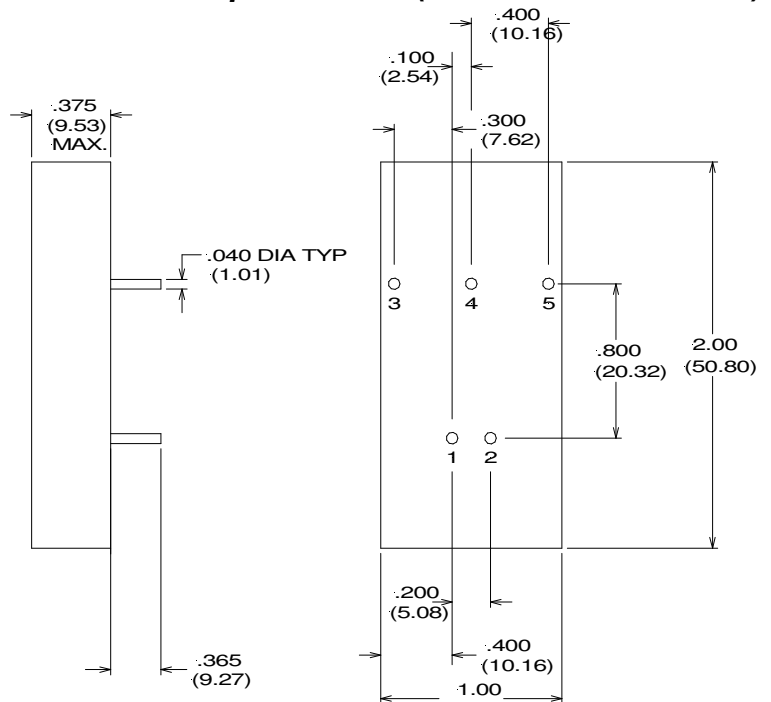
Mechanical Specification (dimensions in inches)

Reliability Power Locations

HEADQUARTERS & CUSTOMER SERVICE	SALES
Reliability Power, Incorporated 33 Musick Irvine, CA 92618 USA Tel: (949) 305-6700 Fax: (949) 305-6701	Reliability Power, Incorporated Attention: SALES Tel: (805) 449-1667 Fax: (805) 557-4530
www.reliabilitypower.com	sales@reliabilitypower.com